

Type C718 thyristor is suitable for phase control applications such as HMDC valves, static VAR compensators and synchronous motor drives.

The silicon junction is manufactured by the proven multi-diffusion process and is supplied in an industry standard disc-type package, ready to mount to forced or naturally cooled heat dissipators using commercially available mechanical clamping hardware.

C718 Thyristor
ON-STATE CHARACTERISTIC

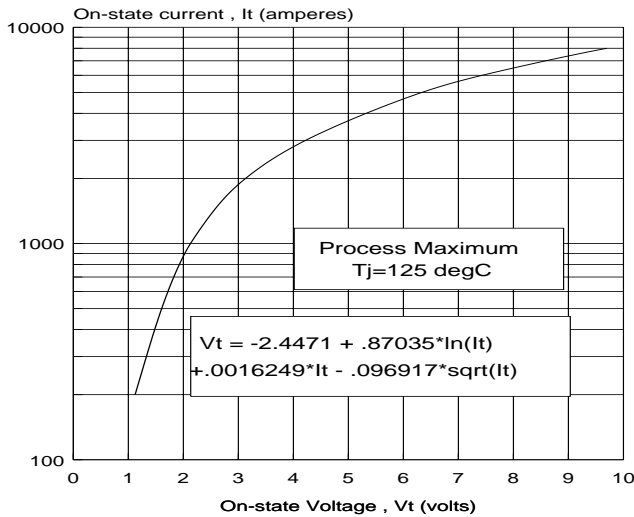

MECHANICAL OUTLINE

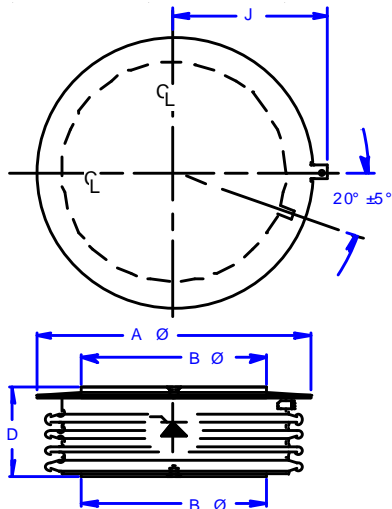

A Φ = 2.96 in (75.2 mm)
B Φ = 1.90 in (48.3 mm)
D = 1.07 in (27.2 mm)

PRINCIPAL RATINGS AND CHARACTERISTICS

Repetitive peak off-state & reverse volts	V_{DRM} V_{RRM}	$T_j=0$ to 125°C	up to 5000	V
Repetitive working crest voltage	V_{DWM} V_{RRM}	$T_j=0$ to 125°C	0.8V _{DRM} 0.8V _{RRM}	
Off-state & reverse leakage current	I_{DWM} I_{RRM}	$T_j=0$ to 125°C	75 75	ma
Average on-state current	$I_{T(AV)}$	$T_{case} =$ 70°C	750	A
Peak half-cycle non-rep surge current	I_{TSM}	60 Hz 50 Hz	7 6.5	kA
On-state voltage	V_{TM}	$I_T=1kA$ $t_b=8ms$ $T_j=125°C$	21	V
Critical rate of rise of on-state current	di/dt_{sp}	$T_j=125°C$ 60 Hz	75	A/us
Critical rate of rise of off-state voltage	dv/dt	$T_j=125°C$ $V_D = .67V_{DRM}$	1000	V/us
Recovery current	I_{RM}	$T_j=125°C$ 2A/us 5A/us	60 100	A
Turn-on delay	t_a	$V_d = .5V_{DRM}$	3	us
Turn-off time	T_{off}	5A/us, -100V 20V/us to 2000V	500	us
Thermal resistance	R_{thJC}		.025	c/w
Externally applied clamping force	F		5500 24.5	lb. kN

**REPETITIVE PEAK REVERSE
AND OFF-STATE BLOCKING
VOLTAGE**

$T_j = 0$ to 125°C

MODEL	V_{DRM} (volts)	V_{RRM} (volts)
C718EP	5000	5000
C718DT	4900	4900
C718DN	4800	4800
C718DS	4700	4700
C718DM	4600	4600
C718DE	4500	4500

Full Cycle Average Power Loss per C718 Thyristor

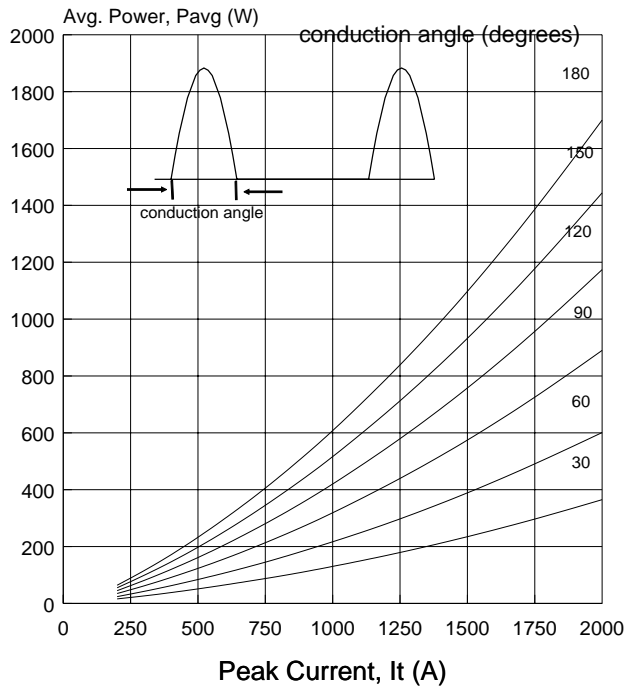

MAXIMUM PEAK RECOVERY CURRENT versus COMMUTATING di/dt

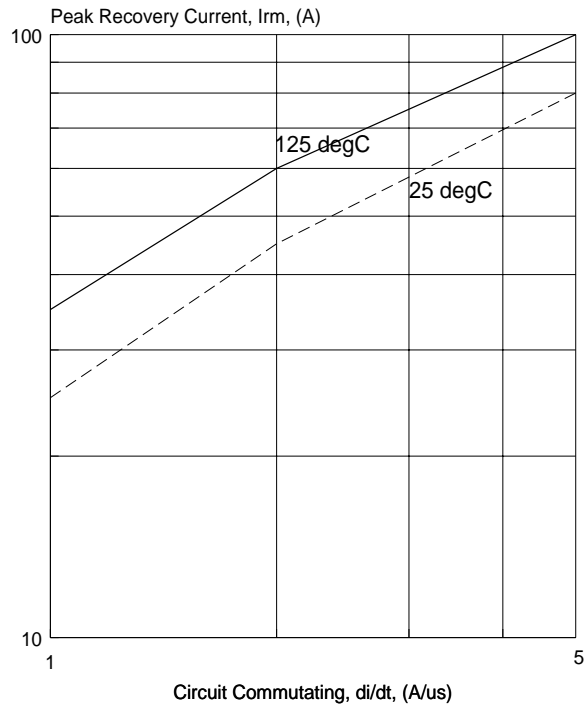

FULL CYCLE AVERAGE POWER LOSS versus PEAK CURRENT at 50/60 Hz (plasma spreading and conduction loss)

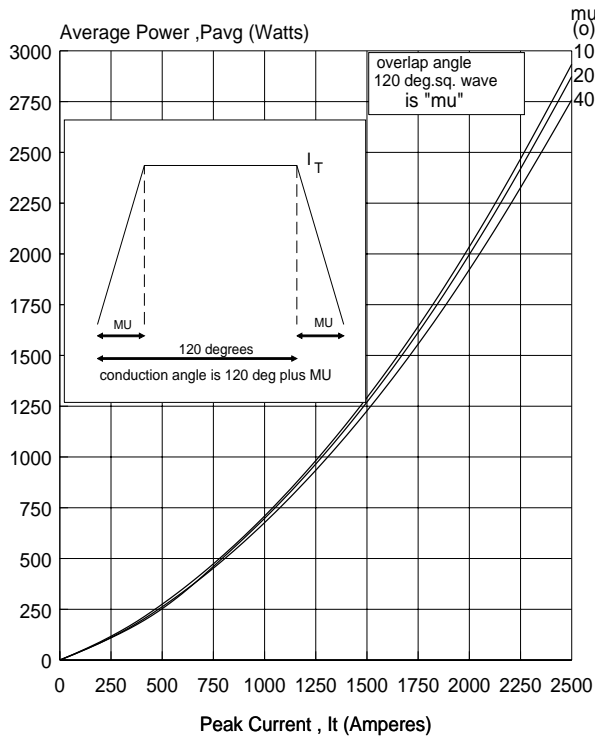

GATE SUPPLY REQUIREMENTS

Open circuit voltage	30 V
Short circuit current	3 A
- rise time	0.5 μ s
Pulse duration (min)	20 μ s