

SDT123

53mm / 9kV THYRISTOR

Type SDT123 thyristor is suitable for phase control applications such as HVDC valves, static VAR compensators and synchronous motor drives. The silicon junction is manufactured by the proven multi-diffusion process and is supplied in an industry standard disc-type package, ready to mount to forced or naturally cooled heat dissipators using commercially available mechanical clamping hardware.

ON-STATE CHARACTERISTIC

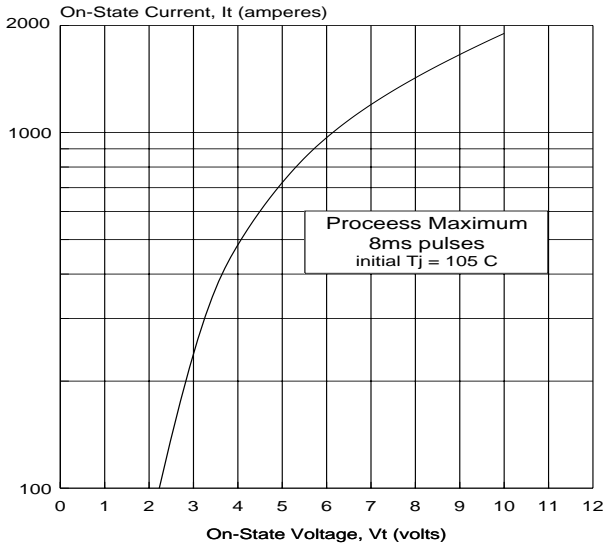

MECHANICAL OUTLINE

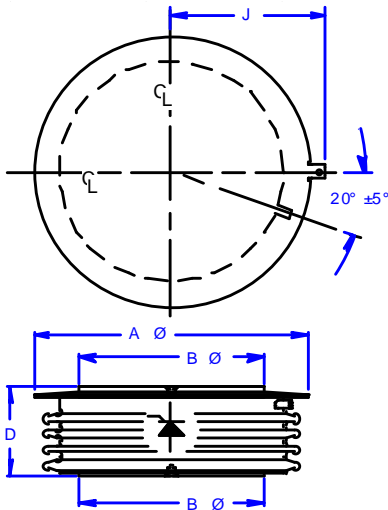

A Φ = 2.96 in (75.2 mm)
B Φ = 1.90 in (48.3 mm)
D = 1.07 in (27.2 mm)

PRINCIPAL RATINGS AND CHARACTERISTICS

Repetitive peak off-state & reverse volts	V_{DRM} V_{RRM}	$T_J=0$ to 110°C	up to 9000	V
Repetitive working crest voltage	V_{DWM} V_{RWM}	$T_J=0$ to 110°C	$0.8V_{DRM}$ $0.8V_{RRM}$	V
off-state & reverse leakage current	I_{DWM} I_{RWM}	$T_J=0$ to 110°C	100 100	ma
Average on-state current	$I_{T(AV)}$	$T_{case} = 70^\circ\text{C}$	300	A
Peak half-cycle non-rep surge current	I_{TSM}	60 Hz 50 Hz	2650 2350	A
On-state voltage	V_{TM}	$I_T=500\text{A}$ $t_p=8\text{ms}$ $T_J=105^\circ\text{C}$	4.0	V
Critical rate of rise of on-state current	di/dt_{rep}	$T_J=110^\circ\text{C}$ 60 Hz	40	A/us
allowable snubber discharge	$V_d = .67V_{DRM}$		50	A
Critical rate of rise of off-state voltage	dv/dt	$T_J=110^\circ\text{C}$ $V_{DCRIT} = 60\% V_{DRM}$	2000	V/us
Recovery current	I_{RM}	$T_J=110^\circ\text{C}$ 2A/us 5A/us	85 135	A
		minimum snub factor $S = 0.3$		
Turn-on delay	t_a	$V_d = .5V_{DRM}$	8	us
Turn-off time	T_{off}	5A/us, -100V 20V/us to 2000V	900	us
Thermal resistance	R_{thJC}		.025	c/w
Externally applied clamping force	F		5500 24.5	lb kN
Gate Drive:			50V / 10 ohm / 0.5us risetime 20us pulse duration	

REPETITIVE PEAK REVERSE AND OFF-STATE BLOCKING VOLTAGE

MODEL	V_{DRM} (volts)	V_{RRM} (volts)
SDT123RT	9000	9000
SDT123RK	8500	8500
SDT123PT	7000	8000
SDT123PK	7500	7500

FULL CYCLE AVERAGE POWER LOSS
versus
PEAK CURRENT at 50/60 Hz
(plasma spreading and conduction loss)

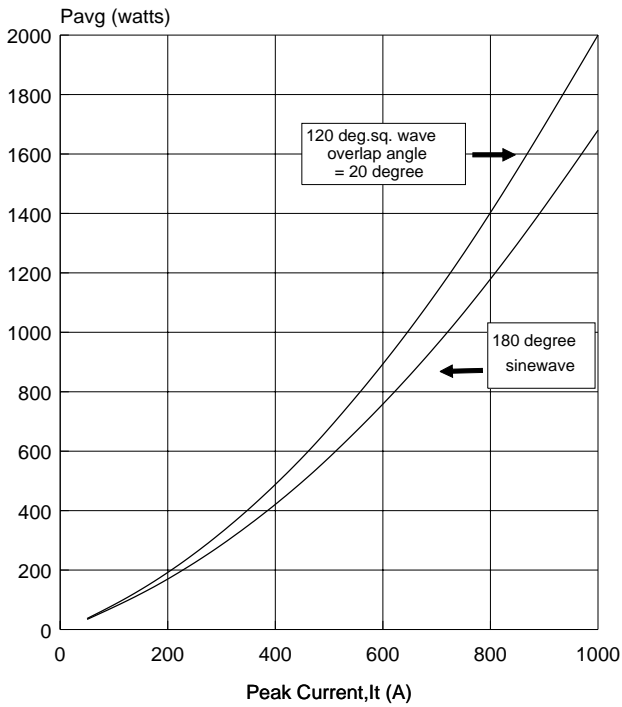

MAXIMUM PEAK RECOVERY CURRENT
T_J = 110 C

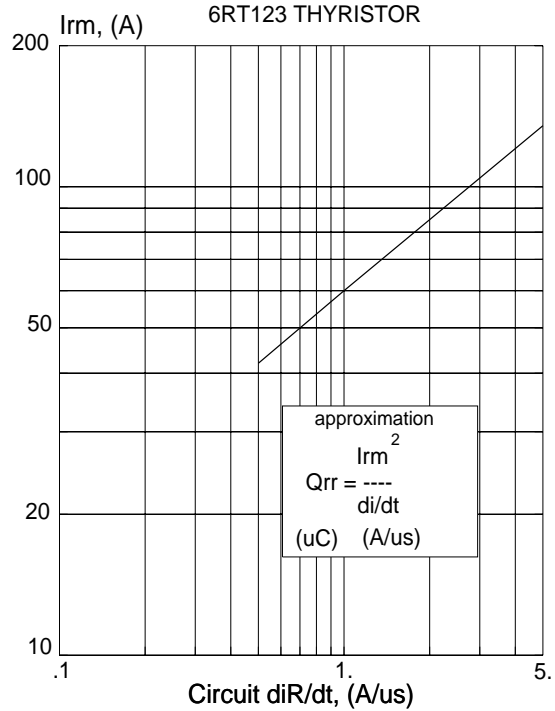

95c:T123 5/6/95

Full Cycle Power Loss (watts)
50/60 Hz, T_J=110°C

I _T (peak) (A)	Half-sine 180°	3 Phase 120°
50	34	37
100	75	82
150	119	133
200	169	191
250	224	255
300	284	326
350	350	403
400	420	487
450	496	577
500	577	675
600	755	889
700	954	1130
800	1175	1397
900	1417	1692
1000	1680	2014

GATE SUPPLY REQUIREMENTS

Open circuit voltage	40 V
Short circuit current	4 A
- rise time	0.5μs
Pulse duration (min)	20 μs