

Type C795 thyristor is suitable for phase control applications such as high voltage valves used on static Var compensators and thyristor controlled series compensation. It is especially optimized to handle frequently applied heavy surge currents as needed for pulse power circuits. The silicon junction is manufactured by the proven multi-diffusion process and is supplied in an industry accepted disc-type package, suitable for mounting directly to heat dissipators using commercially available mechanical clamping hardware.

### ON-STATE CHARACTERISTIC

initial  $T_j = 125^\circ\text{C}$

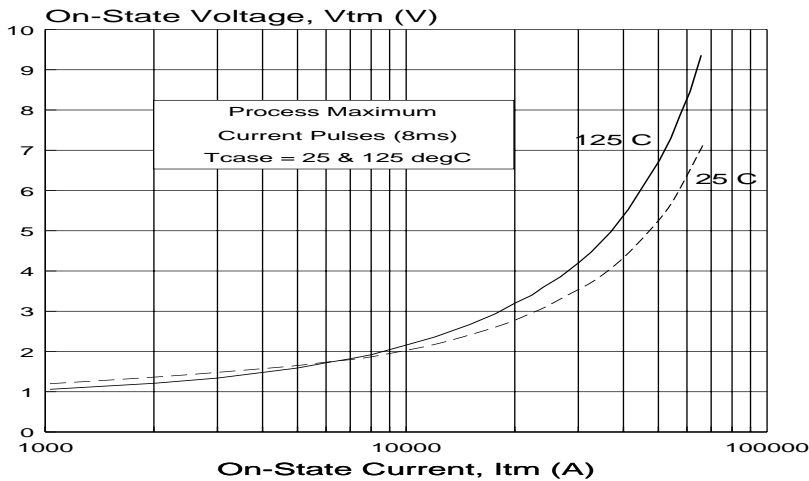

92J:

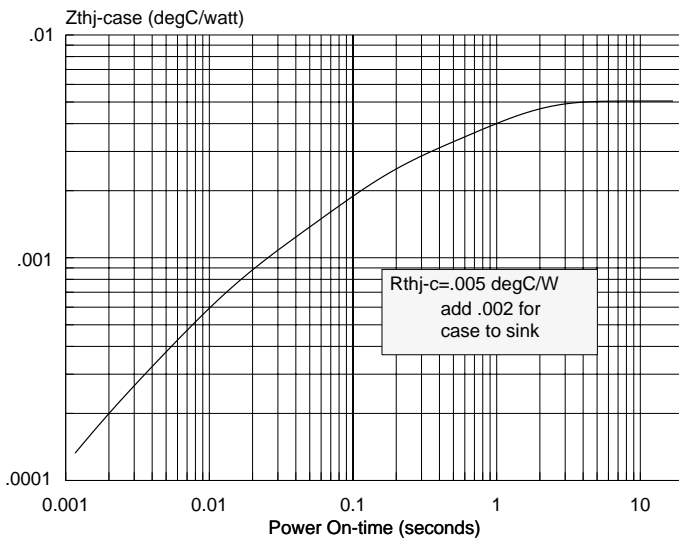

o1a:t305tau

### REPETITIVE PEAK REVERSE AND OFF-STATE BLOCKING

#### VOLTAGE

$T_j = 0 \text{ to } 125^\circ\text{C}$

MODEL	$V_{DRM}$ (volts)	$V_{RRM}$ (volts)
C795CB	3200	3200
C795CA	3100	3100
C795CP	3000	3000
C795LT	2900	2900
C795LN	2800	2800

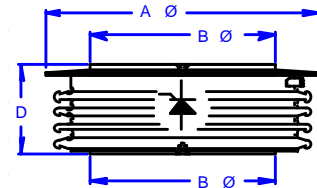
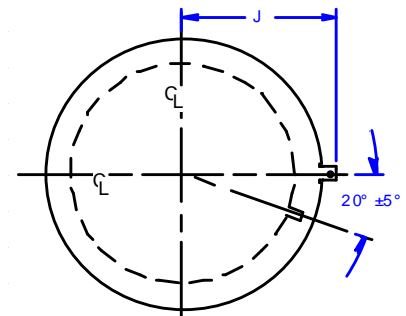

$A \Phi = 5.65 \text{ in (143.5 mm)}$   
 $B \Phi = 3.92 \text{ in (99.4 mm)}$   
 $D = 1.45 \text{ in (36.8 mm)}$

### ELECTRICAL CREEPAGE / STRIKE

1.6 / 1.0 in  
 40.6 / 25.4 mm

### CLAMPING FORCE

(range)  
 17000-19000 lb.

## LIMITING CHARACTERISTICS AND RATINGS

Repetitive peak off-state & reverse volts	$V_{DRM}$ $V_{RRM}$	$T_J=0$ to $125^\circ\text{C}$	up to 3200	V
Repetitive peak off-state & reverse current	$I_{DRM}$ $I_{RRM}$	$T_J=0$ to $125^\circ\text{C}$	300 300	ma
Average on-state current	$I_{T(AV)}$	$T_{case} = 70^\circ\text{C}$	3800	A
Peak half-cycle non-rep surge current	$I_{TSM}$	8.3 ms 2.0 ms $T_J=100^\circ\text{C}$	60 100	kA
On-state voltage	$V_{TM}$	$I_T=4000\text{A}$ $t_T=8.3\text{ms}$ $T_J=125^\circ\text{C}$	1.50	V
Critical rate of rise of on-state current	$di/dt_{rep}$	$T_J=125^\circ\text{C}$ 60 Hz	100	A/us
Critical rate of rise of off-state voltage	$dv/dt$	$T_J=125^\circ\text{C}$ $V_D = .80\% V_{DRM}$	500	V/us
Recovery current	$I_{RM}$	$T_J=105^\circ\text{C}$ 2A/us max. min.	85 55	A
Turn-on delay	$t_a$	$V_d = .5V_{DRM}$	3	us
Turn-off time	$T_{off}$	5A/us, -100V 20V/us to 2000V	400	us
Thermal resistance	$R_{thjc}$		.005	c/w
Externally applied clamping force	F		17000 -19000	lbs

Peak Recovery Current Relationship with Commutating di/dt

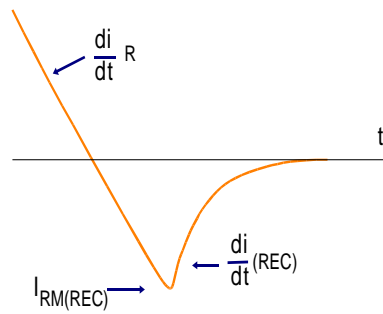
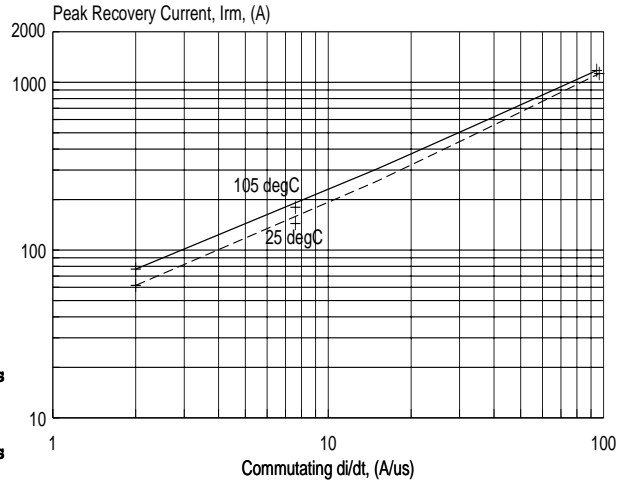

## Gate Characteristics and Gate Supply Requirements

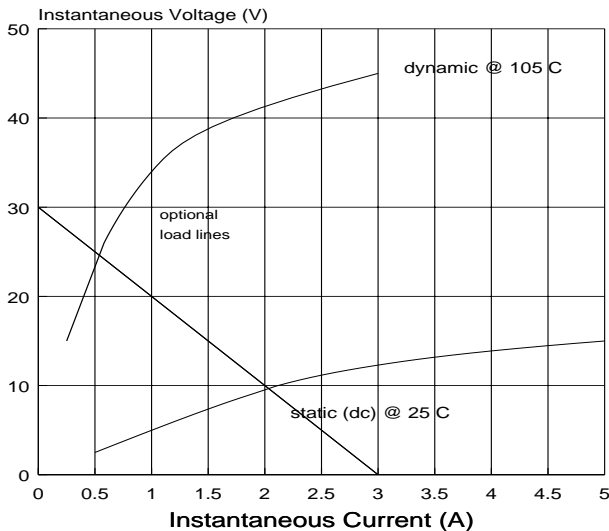

- THYRISTOR GATE IMPEDANCE**  
 Enhanced by fast rising gate voltage, increasing anode bias and junction temperature. It is at a minimum for dc current, zero anode bias and low temperature.
- GATE SUPPLY**  
 At least 30V/10 ohm is necessary to support the di/dt rating and life expectancy. The short circuit current risetime should be nominally 0.5us and the duration longer than the expected delay time for all magnitudes of anode bias. Practically 10-30us is recommended followed by a back porch of 750ma if needed to sustain conduction.
- MINIMUM ACCEPTABLE GATE CURRENT**  
 The intersection of the load line and gate impedance characteristic indicates the minimum value of actual current needed during the delay time interval to support di/dt. A different load line meeting this criterion may be used.
- MAXIMUM GATE RATINGS**  
 Peak gate power,  $P_{gm}(100\text{us}) = 300\text{ W}$   
 Average gate power,  $P_{g(av)} = 50\text{ W}$   
 Peak gate current,  $I_{gfm} = 25\text{ A}$   
 Peak reverse voltage,  $V_{grm} = 25\text{ V}$

## FULL CYCLE AVERAGE POWER DISSIPATION

Sine Wave - includes spread loss  
as function of conduction angle

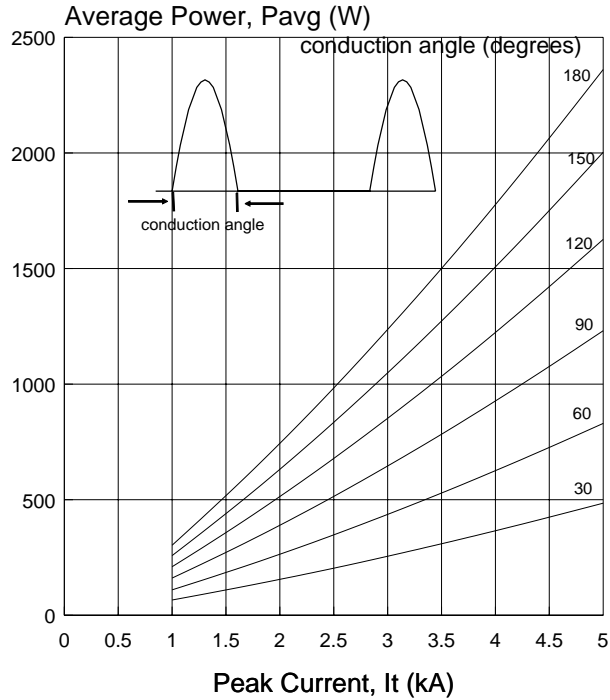

Peak Current $I_T$ (A)	Conduction Angle					
	180°	150°	120°	90°	60°	30°
	Full Cycle Average Power (watts)					
1000	303	258	210	161	110	66
1500	514	437	355	270	184	109
2000	741	629	512	388	263	155
2500	981	833	677	513	347	203
3000	1234	1047	851	645	436	255
3500	1498	1271	1032	782	528	309
4000	1774	1505	1222	926	625	365
4500	2062	1749	1420	1075	725	424
5000	2361	2003	1626	1231	830	485

92J:

## FULL CYCLE AVERAGE POWER DISSIPATION

120-deg Conduction -includes spread loss  
as function of overlap angle, U

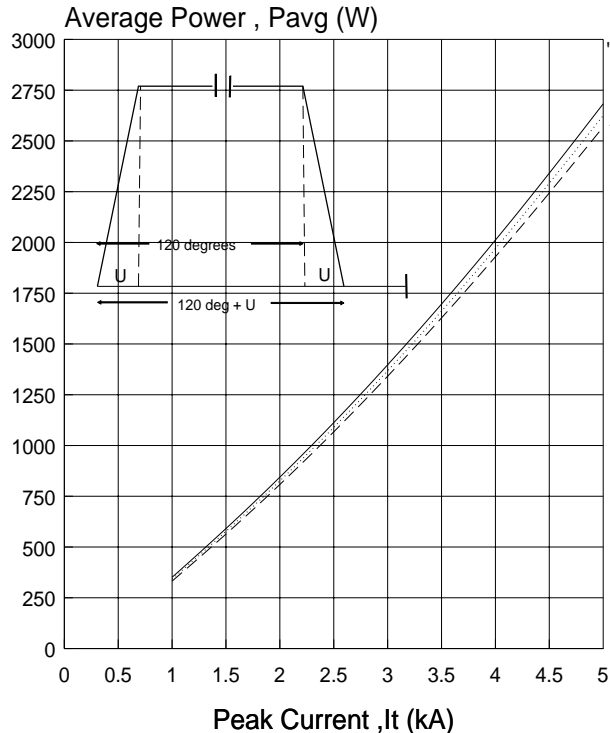

Peak Current $I_T$ (A)	Overlap Angle		
	$u=2^\circ$	$u=20^\circ$	$u=40^\circ$
	Full Cycle Average Power (watts)		
1000	351	342	332
1500	587	573	560
2000	841	823	805
2500	1100	1087	1065
3000	1395	1366	1339
3500	1694	1659	1626
4000	2009	1967	1927
4500	2338	2289	2241
5000	2683	2625	2569

92j:

## Non-Repetitive Surge Current and $I^2t$ for Fusing

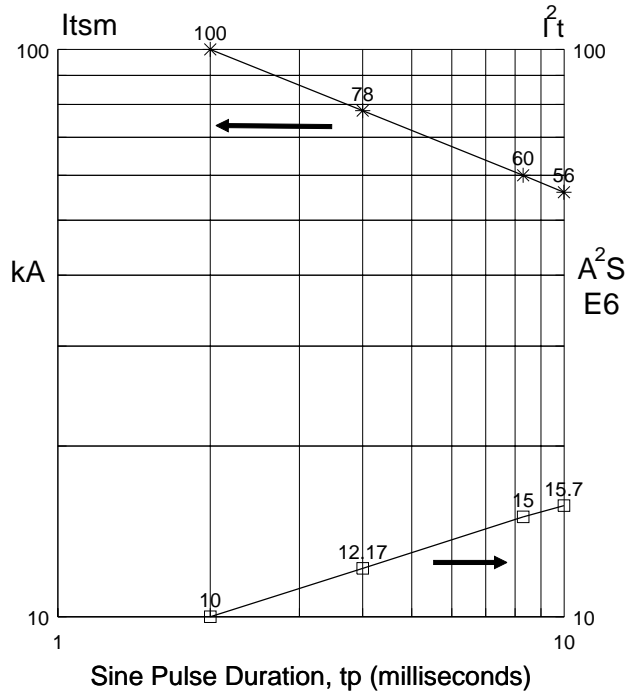

92J:

### MOUNTING PRESSPAKS TO HEAT DISSIPATORS

The following instruction is essential for maintaining low, stable thermal and electrical resistances associated with the PRESSPAK to heat dissipator surfaces.

#### 1. INSPECTION OF MATING SURFACES

Check each mating surface for nicks, scratches and surface finish. The PRESSPAK surface has a total indicator reading TIR < .0005 inch and surface finish 32 prior to factory electrical test in pressure fixtures. The dissipator surface should be equally as good. The TIR of a fully tested PRESSPAK may run higher but not exceed 0.002 inch not including some minor nicks and scratches associated with the test fixtures. Any bow created by clamp system at assembly must keep flatness within 0.002 inch.

#### 2. SURFACE DEOXIDATION AND CLEANING

Although plated surfaces are recommended for aluminum and copper heat dissipators, bare surfaces may be used if careful attention to cleaning and treating is assured. Plated surfaces and PRESSPAKS should be lightly sanded with 600 grit paper, then oil or compound applied as recommended. Unplated aluminum surfaces should be vigorously abraded with a fine wire brush or 3M "Scotchbrite" coated with Alcoa EJC #2 compound. The EJC # 2 should be removed and the recommended compound applied.

#### 3. FINAL SURFACE TREATMENT

Apply silicone oil or a very thin layer of grease or compound as indicated below. Rotate the PRESSPAK to properly distribute the applied agent.

- . bare copper - use G322L or LS2037
- . bare aluminum - use EJC #2 or G322L
- . tin plated copper or aluminum
  - preferably reapply DC550 or SF1154
  - alternatively use G623 or G322L
- . nickel plated aluminum - use DC550, G623 or G322L
- . silver plating - not recommended

Recommended silicone oils are SF1154 or DC550 (200 centistoke)

#### 4. MOUNTING

Assemble with specified mounting force applied through a self-leveling swivel connection. The diameter of the swivel should be preferably equal but not smaller than the poleface diameter of the PRESSPAK. Center holes on the top and bottom of the PRESSPAK are for locating.

#### NOTES:

Silicone oil DC550 (200 centistoke) is a product of DOW CORNING; clear silicone grease G623, yellow G322L and SF1154 (200 centistoke) GE Silicones Waterford NY; EJC# 2 from ALCOA and black LS2037 from ARCO, 7301 Bessemer Ave. Cleveland OH.

Limit maximum joint temperature to:

- 95 C using EJC #2
- 150 C using SF1154, DC550 or G322L

#### 5. APPLIED MOUNTING FORCE

The selection of an appropriate commercially available spring clamping hardware\* should consider establishing and maintaining the specified mounting force over the operating temperature range and operating life of the PRESSPAK. Thus essential ratings such as thermal resistance, di/dt, surge current and thermal cycling will not be impaired.

Specified forces for this product are as follows:

- 17000-19000 lbs.
- 75.6 - 84.5 kN
- 7725 - 9500 kg

\* Consult factory for recommendations or more detailed instructions.