

Type C791A thyristor is suitable for phase control applications such as for HVDC valves, static VAR compensators and synchronous motor drives. The silicon junction design utilizes a second generation pilot gate and a unique orientation of emitter shorts which promote the lateral expansion of conducting plasma resulting in lower spreading losses while achieving high dv/dt withstand. It is supplied in an industry accepted disc-type package, ready to mount using commercially available heat dissipators and mechanical clamping hardware.

**MAXIMUM ON-STATE CHARACTERISTIC**  
 Initial T<sub>j</sub>=125 degC

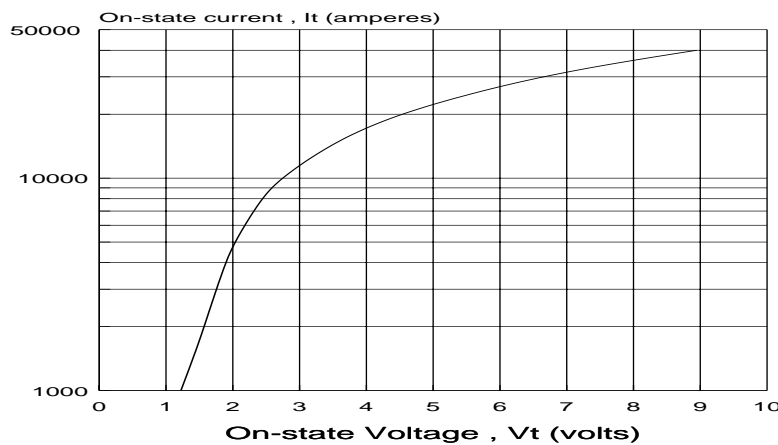

**Thermal Impedance**

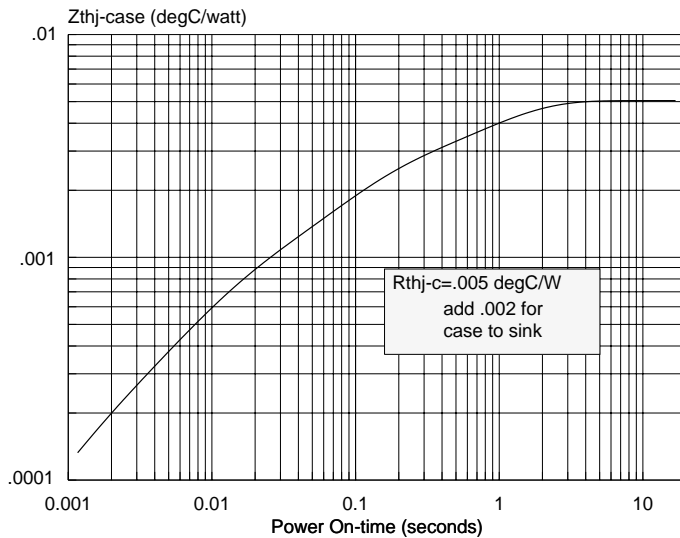

o1a:t305tau

175 GREAT VALLEY PKWY. MALVERN, PA 19355  
 USA

REPETITIVE PEAK REVERSE  
 AND OFF-STATE BLOCKING  
 VOLTAGE

T<sub>j</sub> = 0 to 125°C

MODEL	V <sub>DRM</sub> (volts)	V <sub>RRM</sub> (volts)
C791ADE	4500	4500
C791ADD	4400	4400
C791ADC	4300	4300
C791ADB	4200	4200
C791ADA	4100	4100
C791ADP	4000	4000

MECHANICAL OUTLINE

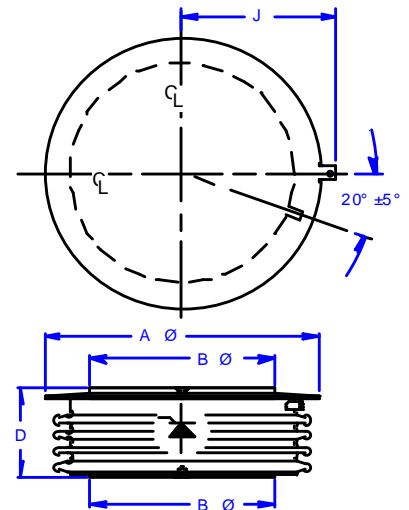

**AΦ = 5.65 in (143.5 mm)**  
**BΦ = 3.92 in (99.4 mm)**  
**D = 1.45 in (36.8 mm)**

ELECTRICAL  
 CREEPAGE / STRIKE

1.6 / 1.0 in  
 40.6 / 25.4 mm

CLAMPING FORCE  
 (range)

17000 - 19000 lb  
 75 - 84 kN

## LIMITING CHARACTERISTICS AND RATINGS

Repetitive peak off-state & reverse volts	$V_{DRM}$ $V_{RRM}$	$T_J=0$ to $125^\circ\text{C}$	up to 4500	V
Repetitive working crest voltage	$V_{DWM}$ $V_{DRM}$	$T_J=0$ to $125^\circ\text{C}$	$0.8V_{DRM}$ $0.8V_{RRM}$	
Off-state & reverse leakage current	$I_{DRM}$ $I_{RRM}$	$T_J=0$ to $125^\circ\text{C}$	450 350	ma
Average on-state current	$I_{T(AV)}$	$T_{case} = 70^\circ\text{C}$	3250	A
Peak half-cycle non-rep surge current	$I_{TSM}$	60 Hz 50 Hz	42 38	kA
On-state voltage	$V_{TM}$	$I_T=4000\text{A}$ $t_p=8.3\text{ms}$ $T_J=125^\circ\text{C}$	2.00	V
Critical rate of rise of on-state current	$di/dt_{rep}$	$T_J=125^\circ\text{C}$ 60 Hz	100	A/us
Critical rate of rise of off-state voltage	$dv/dt$	$T_J=125^\circ\text{C}$ $V_D=.67V_{DRM}$	1000	V/us
Recovery current	$I_{RM}$	$T_J=105^\circ\text{C}$ 2A/us 5A/us	90 195	A
Turn-on delay	$t_a$	$V_d=.5V_{DRM}$	4	us
Turn-off time	$T_{off}$	5A/us, -100V 20V/us to 2000V	500	us
Thermal resistance	$R_{thjc}$		.007	c/w
Externally applied clamping force	F		17000 -19000	lb

Gate Characteristics and Gate Supply Requirements

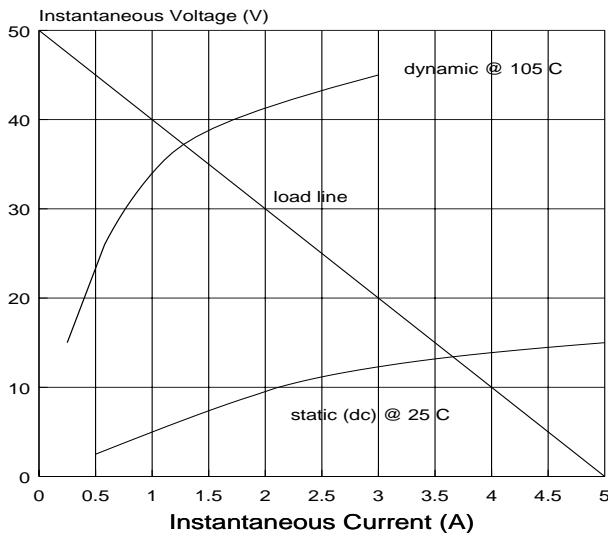

- THYRISTOR GATE IMPEDANCE**  
 Enhanced by fast rising gate voltage, increasing anode bias and junction temperature. It is at a minimum for dc current, zero anode bias and low temperature.
- GATE SUPPLY**  
 Prefer 50V/10 ohm for supporting the di/dt rating and life expectancy. The short circuit current risetime should be nominally 0.5us and the duration longer than the expected delay time for all magnitudes of anode bias. Practically 10-30us is recommended followed by a back porch of 750ma if needed to sustain conduction.
- MINIMUM ACCEPTABLE GATE CURRENT**  
 The intersection of the load line and gate impedance characteristic indicates the minimum value of actual current needed during the delay time interval to support di/dt. A different load line meeting this criterion may be used.
- MAXIMUM GATE RATINGS**  
 Peak gate power,  $P_{gm}(100\text{us}) = 300\text{ W}$   
 Average gate power,  $P_{g(av)} = 50\text{ W}$   
 Peak gate current,  $I_{gfm} = 25\text{ A}$   
 Peak reverse voltage,  $V_{grm} = 25\text{ V}$

**FULL CYCLE AVERAGE POWER DISSIPATION**  
 120-deg Conduction -includes spread loss  
 as function of Overlap Angle, U

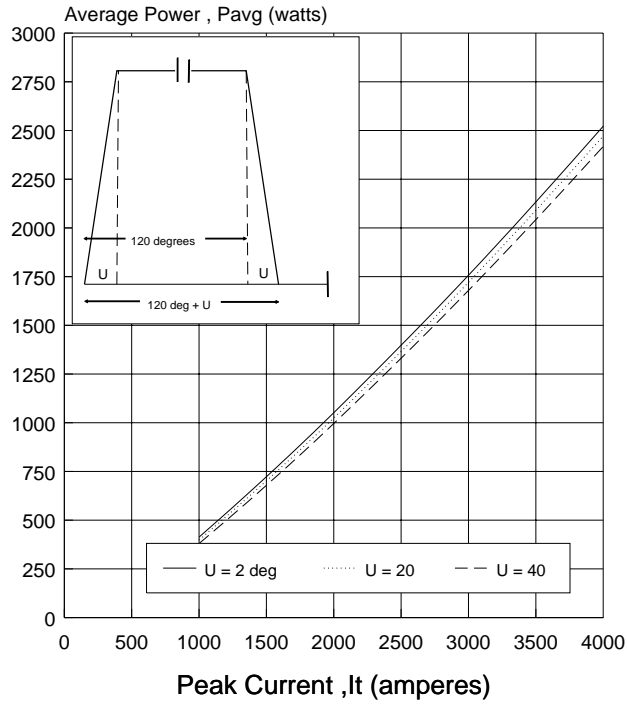

4500V 100mm

**PEAK RECOVERY CURRENT**  
 versus  
 COMMUTATING  $di/dt$

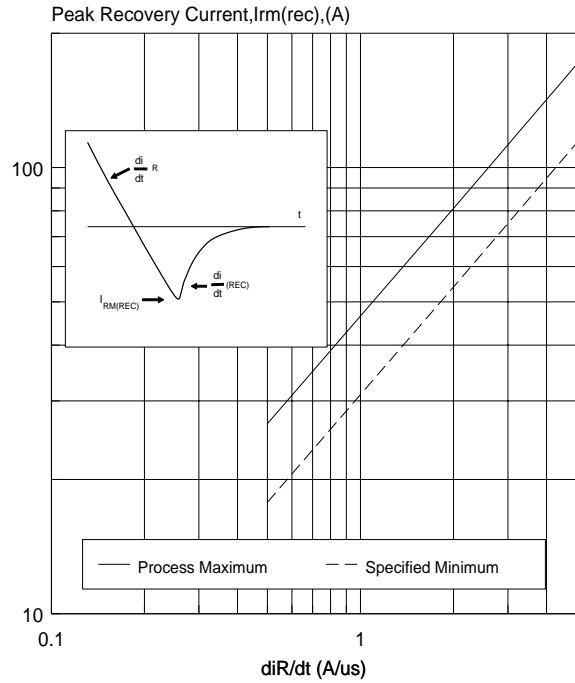

6RT302

**FULL CYCLE AVERAGE POWER DISSIPATION**  
 Sine Wave - includes spread loss  
 as function of conduction angle

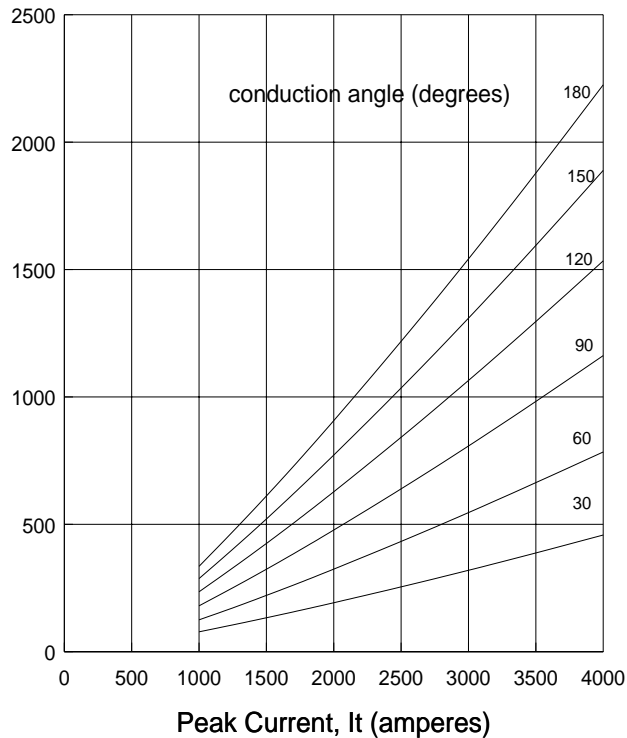

4.5kv 100mm

**INRUSH CURRENT ( $di/dt$ ) RATING**  
 versus  
 SWITCHING VOLTAGE

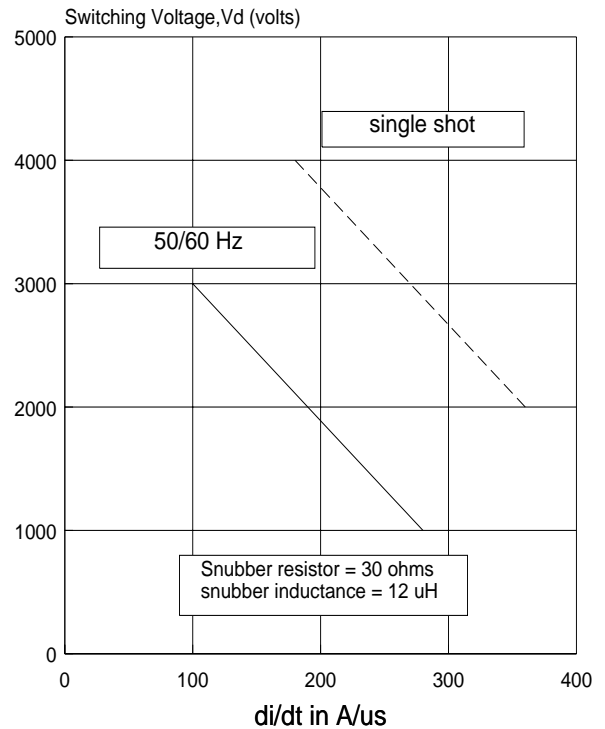

T302