

Type C791 thyristor is suitable for phase control applications such as for HVDC valves, static VAR compensators and synchronous motor drives. The silicon junction design utilizes a second generation pilot gate and a unique orientation of emitter shorts which promote the lateral expansion of conducting plasma resulting in lower spreading losses while achieving high dv/dt withstand. It is supplied in an industry accepted disc-type package, ready to mount using commercially available heat dissipators and mechanical clamping hardware.

**On-State Characteristic**

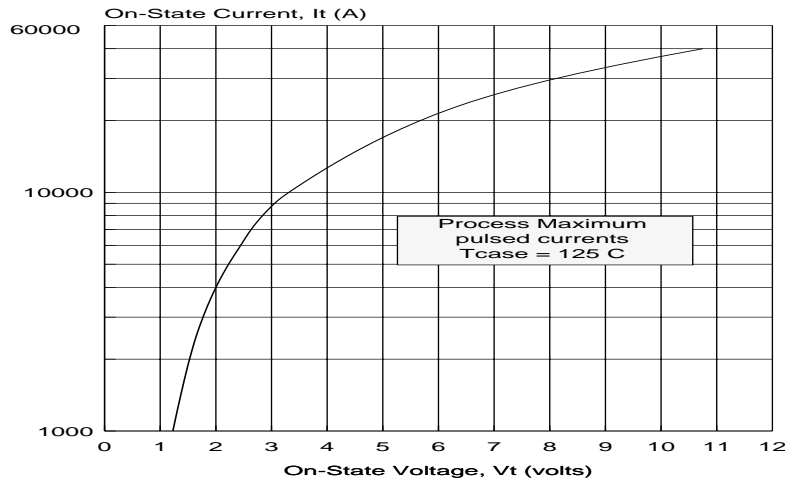

01a:C791

**Thermal Impedance**

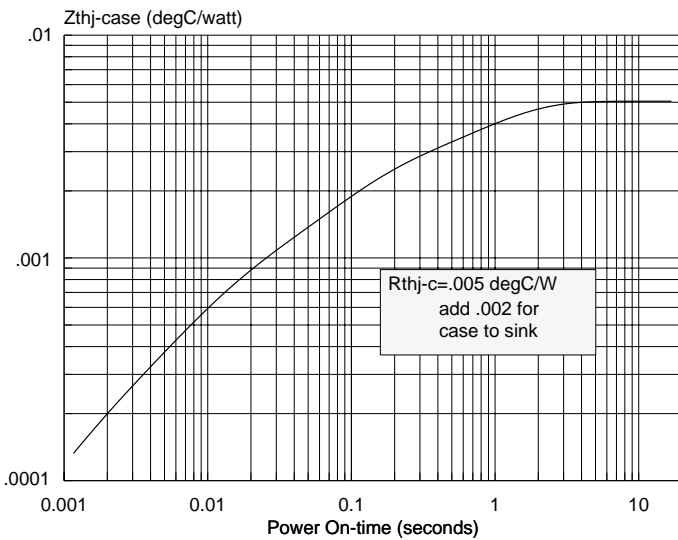

01a:t305tau

**REPETITIVE PEAK REVERSE AND OFF-STATE BLOCKING VOLTAGE**

$T_j = 0 \text{ to } 125^\circ\text{C}$

MODEL	$V_{DRM}$ (volts)	$V_{RRM}$ (volts)
C791EP	5000	5000
C791DT	4900	4900
C791DN	4800	4800
C791DS	4700	4700
C791DM	4600	4600
C791DE	4500	4500

**MECHANICAL OUTLINE**

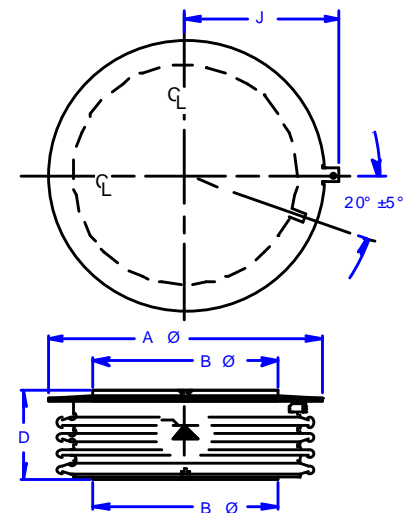

**AF = 5.65 in (143.5 mm)**  
**BF = 3.92 in (99.4 mm)**  
**D = 1.45 in (36.8 mm)**

**ELECTRICAL CREEPAGE / STRIKE**

**1.6 / 1.0 in**  
**40.6 / 25.4 mm**

**CLAMPING FORCE**

**(range)**  
**17000-19000 lb.**

**LIMITING CHARACTERISTICS AND RATINGS**

Repetitive peak off-state & reverse volts @ 5Hz	$V_{DRM}$ $V_{RRM}$	$T_J=0$ to 125°C	up to 5000	V
Repetitive working crest voltage, 60Hz	$V_{DWM}$ $V_{DRM}$	$T_J=0$ to 125°C	$0.8V_{DRM}$ $0.8V_{RRM}$	
Off-state & reverse leakage current, 60Hz	$I_{DWM}$ $I_{RRM}$	$T_J=0$ to 125°C	200 200	ma
Average on-state current	$I_{T(AV)}$	$T_{case} = 70^\circ C$	3600	A
Peak half-cycle non-rep surge current	$I_{TSM}$	60 Hz 50 Hz	44.5 41.5	kA
On-state voltage	$V_{TM}$	$I_T=4000A$ $t_p=8.3ms$ $T_J=125^\circ C$	2.00	V
Critical rate of rise of on-state current	$di/dt_{rep}$	$T_J=125^\circ C$ 60 Hz	100	A/us
Critical rate of rise of off-state voltage	$dv/dt$	$T_J=125^\circ C$ $V_D=.67V_{DRM}$	1000	V/us
Recovery current	$I_{RM}$	$T_J=125^\circ C$ 2A/us 5A/us	90 195	A
Turn-on delay	$t_d$	$V_d=.5V_{DRM}$	4	us
Turn-off time	$T_{off}$	5A/us, -100V 20V/us to 2000V	500	us
Thermal resistance	$R_{thJC}$		.005	c/w
Externally applied clamping force	F		17000 -19000	lb

Non-Repetitive Surge Current and I2t for Fusing

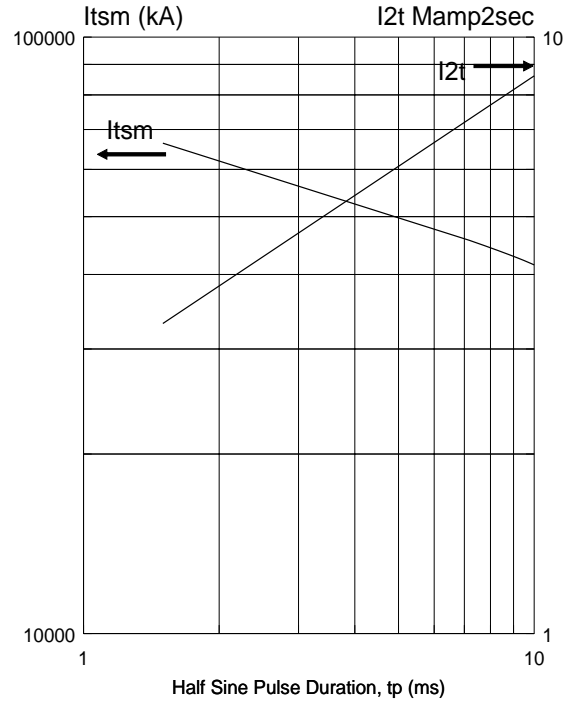

01:C791ITSM

Gate Characteristics and Gate Supply Requirements

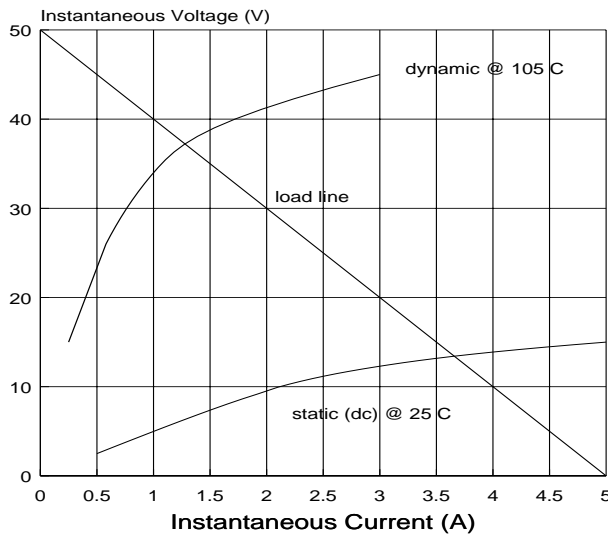

- **THYRISTOR GATE IMPEDANCE**  
Enhanced by fast rising gate voltage, increasing anode bias and junction temperature. It is at a minimum for dc current, zero anode bias and low temperature.
- **GATE SUPPLY**  
Prefer 50V/10 ohm for supporting the di/dt rating and life expectancy. The short circuit current risetime should be nominally 0.5us and the duration longer than the expected delay time for all magnitudes of anode bias. Practically 10-30us is recommended followed by a back porch of 750ma if needed to sustain conduction.
- **MINIMUM ACCEPTABLE GATE CURRENT**  
The intersection of the load line and gate impedance characteristic indicates the minimum value of actual current needed during the delay time interval to support di/dt. A different load line meeting this criterion may be used.
- **MAXIMUM GATE RATINGS**  
Peak gate power, P<sub>gm</sub>(100us) = 300 W  
Average gate power, P<sub>g(av)</sub> = 50W  
Peak gate current, I<sub>gfm</sub> = 25 A  
Peak reverse voltage, V<sub>grm</sub> = 25 V

**FULL CYCLE AVERAGE POWER DISSIPATION**  
 120-deg Conduction -includes spread loss  
 as function of Overlap Angle , U

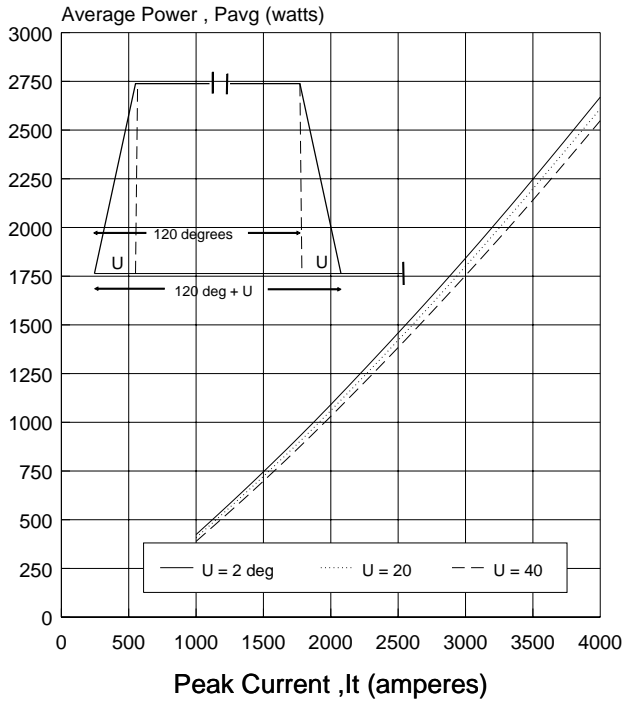

5000V 100mm

**PEAK RECOVERY CURRENT**  
 versus  
 COMMUTATING di/dt

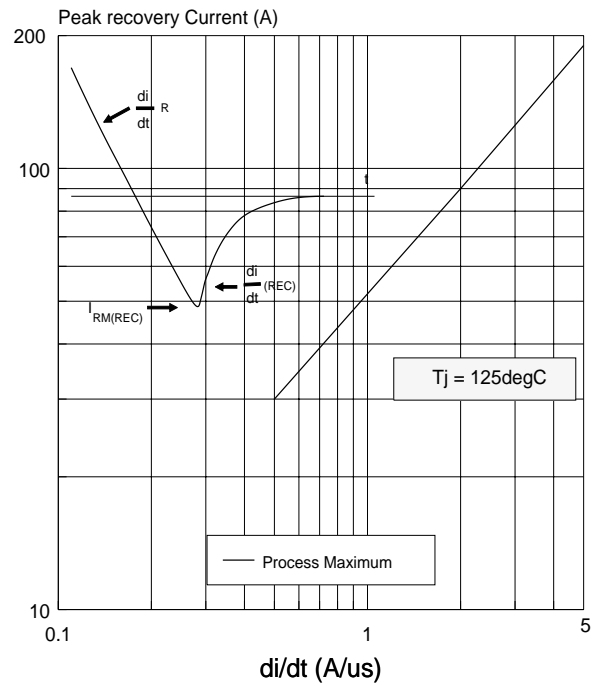

6RT302

**FULL CYCLE AVERAGE POWER DISSIPATION**  
 Sine Wave - includes spread loss  
 as function of conduction angle

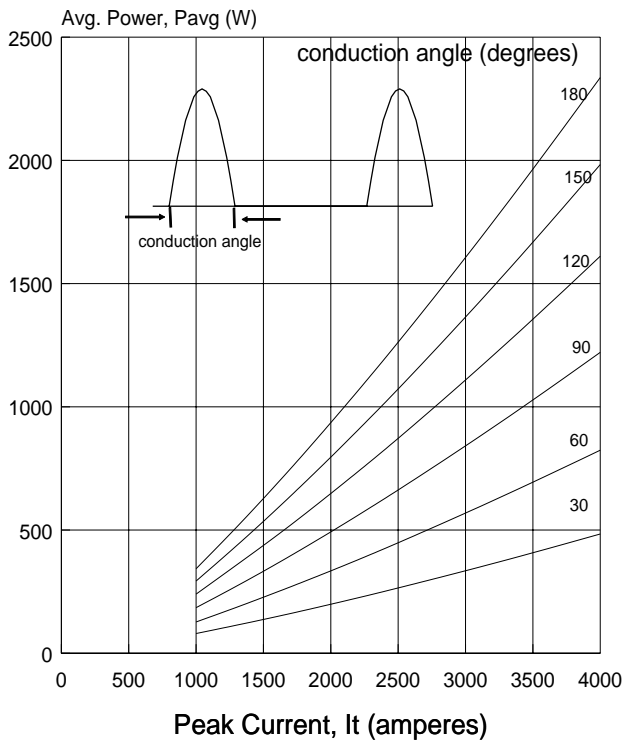

6RT302

**INRUSH CURRENT (di/dt) RATING**  
 versus  
 SWITCHING VOLTAGE

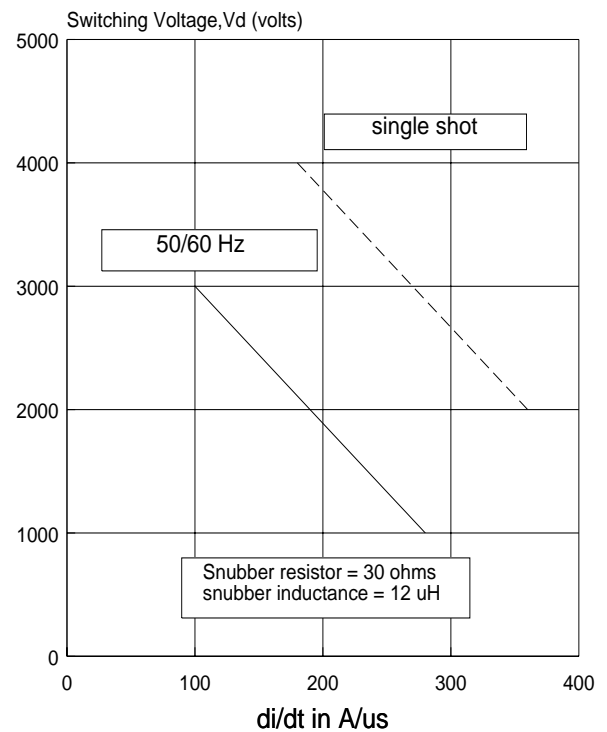

T302