

TRIPLE LDO

NO. EA-099-130424

OUTLINE

The R5324x Series are CMOS-based multi positive voltage regulator ICs with high output voltage accuracy, low supply current, low noise, low dropout and high ripple rejection. The R5324x Series contain three voltage regulators. Each of these voltage regulators in the R5324x Series consists of a voltage reference unit, an error amplifier, resistors for setting output voltage, a short current limit circuit, a chip enable circuit, and so on.

The chip enable function contributes to prolong battery life. Further, regulators in the R5324x Series are with low dropout voltage, excellent load transient response and line transient response, thus the R5324x series are very suitable for the power supply for hand-held communication equipment.

Since the packages for these ICs are SON-8 (Non-promotion) and DFN(PLP)2527-10, high density mounting of the ICs on boards is possible.

FEATURES

- Supply Current Typ. 90 μ A (VR1, VR2, VR3)
- Standby Current Typ. 0.1 μ A
- Output Current Min. 200mA (VR1), 150mA (VR2), 100mA (VR3)
- Dropout Voltage Typ. 0.23V (VR1) ($I_{OUT}=200mA$, $V_{OUT}=2.8V$)
Typ. 0.22V (VR2) ($I_{OUT}=150mA$, $V_{OUT}=2.8V$)
Typ. 0.15V (VR3) ($I_{OUT}=100mA$, $V_{OUT}=2.8V$)
- Ripple Rejection Typ. 70dB (f=1kHz), Typ. 65dB (f=10kHz)
- Input Voltage Range 2.0V to 6.0V
- Output Voltage Range 1.5V to 4.0V (0.1V steps)
(For details, please refer to MARK INFORMATION.S.)
- Output Voltage Accuracy $\pm 2.0\%$
- Temperature-Drift Coefficient of Output Voltage Typ. $\pm 100ppm/^{\circ}C$
- Line Regulation Typ. 0.02%/V
- Packages DFN(PLP)2527-10, SON-8 (Non-promotion)
- Built-in fold-back protection circuit Typ. 50mA (VR1), Typ. 40mA (VR2, VR3)
(Current at short mode)
- Ceramic capacitors are recommended to be used with this IC 1.0 μ F or more

APPLICATIONS

- Power source for cellular phones and portable communication equipment.
- Power source for electrical appliances such as cameras, VCRs.
- Power source for battery-powered equipment.

BLOCK DIAGRAMS

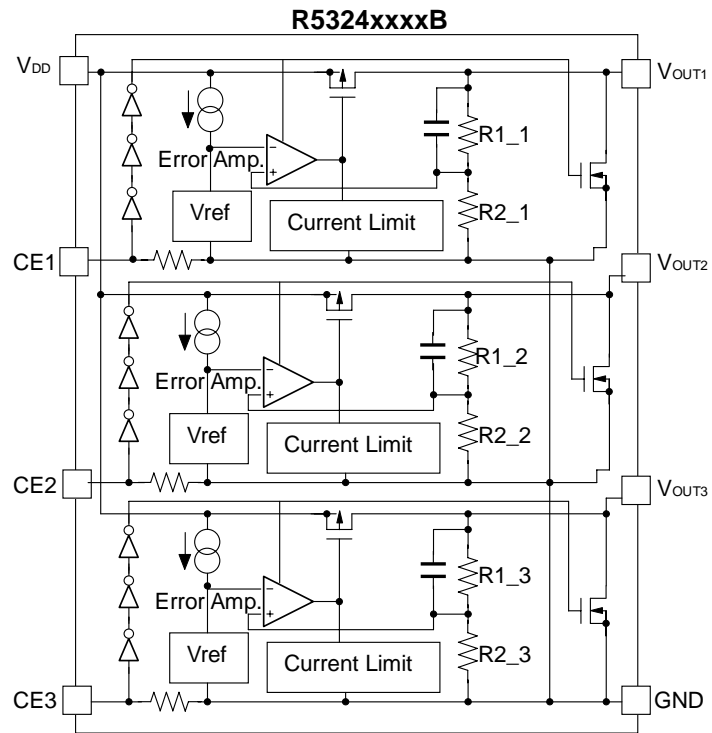
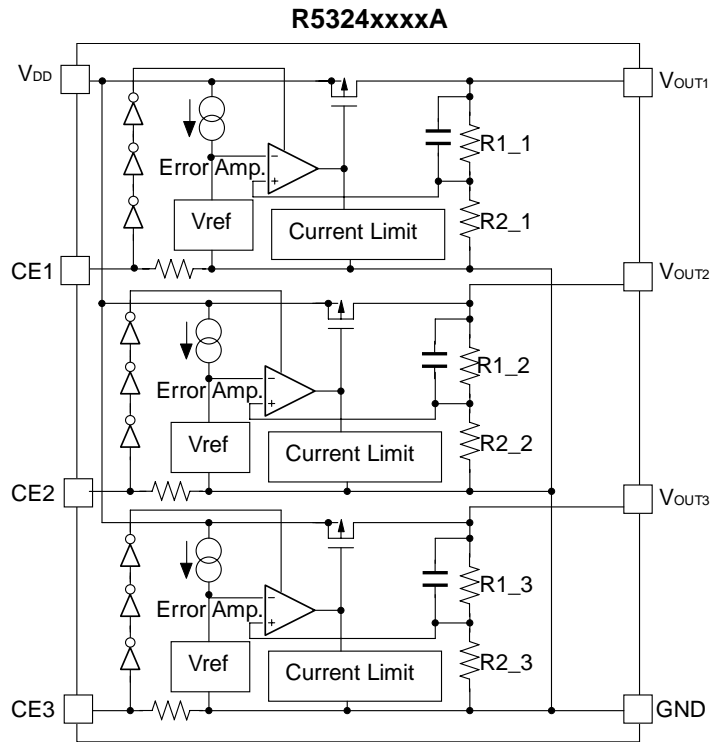

SELECTION GUIDE

The output voltage, auto discharge function, package, etc. for the ICs can be selected at the user's request.

Product Name	Package	Quantity per Reel	Pb Free	Halogen Free
R5324Kxxx*-TR	DFN(PLP)2527-10	5,000 pcs	Yes	Yes
R5324Dxxx*-TR-F	SON-8 (Non-promotion)	3,000 pcs	Yes	No
<p>xxx : The combination of output voltage for each channel can be designated by serial numbers. (from 001) The output voltage for each channel can be set in the range from 1.5V to 4.0V in 0.1V steps. (For details, please refer to MARK INFORMATIONS.)</p> <p>* : The auto discharge function at off state are options as follows. (A) without auto discharge function at off state (B) with auto discharge function at off state</p>				

The products scheduled to be discontinued : "Non-promotion"

These products will be discontinued in the future. We advise you to select other products.

PIN CONFIGURATIONS

• DFN (PLP) 2527-10

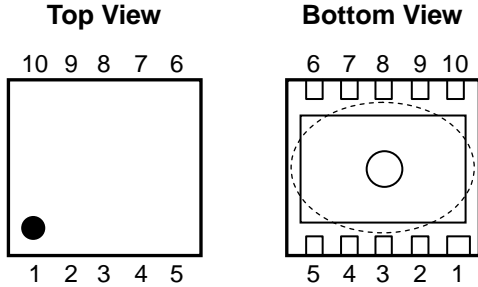

• SON-8 (Non-promotion)

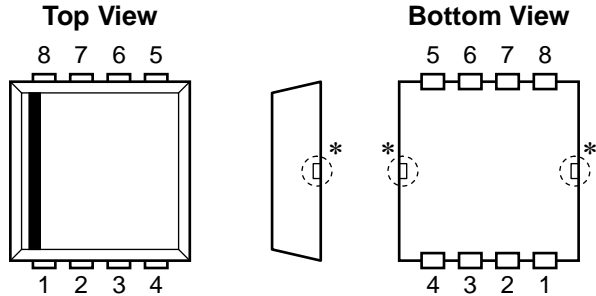

PIN DESCRIPTIONS

• DFN(PLP)2527-10

Pin No	Symbol	Pin Description
1	V _{DD}	Input Pin
2	V _{DD}	Input Pin
3	CE1	Chip Enable Pin 1 ("H" Active)
4	CE2	Chip Enable Pin 2 ("H" Active)
5	CE3	Chip Enable Pin 3 ("H" Active)
6	GND	Ground Pin
7	NC	No Connection
8	V _{OUT3}	Output Pin 3
9	V _{OUT2}	Output Pin 2
10	V _{OUT1}	Output Pin 1

*) Tab is GND level. (They are connected to the reverse side of this IC.)
 The tab is better to be connected to the GND, but leaving it open is also acceptable.
 The V_{DD} pin must be wired together when it is mounted on board.

• SON-8 (Non-promotion)

Pin No	Symbol	Pin Description
1	V _{DD}	Input Pin
2	CE1	Chip Enable Pin 1 ("H" Active)
3	CE2	Chip Enable Pin 2 ("H" Active)
4	CE3	Chip Enable Pin 3 ("H" Active)
5	GND	Ground Pin
6	V _{OUT3}	Output Pin 3
7	V _{OUT2}	Output Pin 2
8	V _{OUT1}	Output Pin 1

*) Tab suspension leads are GND level. (They are connected to the reverse side of this IC.)
 The tab suspension leads should be open and do not connect to other wires or land patterns.

ABSOLUTE MAXIMUM RATINGS

Symbol	Item	Rating	Unit
V_{IN}	Input Voltage	6.5	V
CE	Input Voltage (CE Pin)	-0.3 to 6.5	V
V_{OUT}	Output Voltage	-0.3 to $V_{IN}+0.3$	V
I_{OUT1}	Output Current (V_{OUT1})	230	mA
I_{OUT2}	Output Current (V_{OUT2})	180	mA
I_{OUT3}	Output Current (V_{OUT3})	180	mA
P_D	Power Dissipation (DFN(PLP)2527-10)*	910	mW
	Power Dissipation (SON-8)* (Non-promotion)	480	
T_{opt}	Operating Temperature Range	-40 to 85	°C
T_{stg}	Storage Temperature Range	-55 to 125	°C

*) For Power Dissipation, please refer to PACKAGE INFORMATION.

ABSOLUTE MAXIMUM RATINGS

Electronic and mechanical stress momentarily exceeded absolute maximum ratings may cause the permanent damages and may degrade the life time and safety for both device and system using the device in the field.

The functional operation at or over these absolute maximum ratings is not assured.

RECOMMENDED OPERATING CONDITIONS (ELECTRICAL CHARACTERISTICS)

All of electronic equipment should be designed that the mounted semiconductor devices operate within the recommended operating conditions. The semiconductor devices cannot operate normally over the recommended operating conditions, even if when they are used over such conditions by momentary electronic noise or surge. And the semiconductor devices may receive serious damage when they continue to operate over the recommended operating conditions.

ELECTRICAL CHARACTERISTICS

• R5324xxxxA/B

VR1

T_{opt}=25°C

Symbol	Item	Conditions	Min.	Typ.	Max.	Unit	
V _{OUT}	Output Voltage	V _{IN} -V _{OUT} =1.0V 1mA ≤ I _{OUT} ≤ 30mA	×0.98		×1.02	V	
I _{OUT}	Output Current	V _{IN} -V _{OUT} =1.0V	200			mA	
ΔV _{OUT} /ΔI _{OUT}	Load Regulation	V _{IN} -V _{OUT} =1.0V, 1mA ≤ I _{OUT} ≤ 200mA		25	50	mV	
V _{DIF}	Dropout Voltage	I _{OUT} =200mA	V _{OUT} =1.5V		0.36	0.65	V
			V _{OUT} =1.6V		0.34	0.58	
			V _{OUT} =1.7V		0.33	0.56	
			1.8V ≤ V _{OUT} ≤ 2.0V		0.31	0.53	
			2.1V ≤ V _{OUT} ≤ 2.7V		0.28	0.46	
			2.8V ≤ V _{OUT} ≤ 4.0V		0.23	0.35	
I _{SS}	Supply Current	V _{IN} -V _{OUT} =1.0V		90	140	μA	
I _{standby}	Standby Current	V _{IN} -V _{OUT} =1.0V, V _{CE} =GND		0.1	1.0	μA	
ΔV _{OUT} /ΔV _{IN}	Line Regulation	I _{OUT} =30mA, V _{OUT} +0.5V ≤ V _{IN} ≤ 6.0V (V _{OUT} ≤ 1.6V: 2.2V ≤ V _{IN} ≤ 6.0V)		0.02	0.10	%/V	
RR	Ripple Rejection	sinusoidal Ripple 0.5Vp-p V _{IN} -V _{OUT} =1.0V, I _{OUT} =30mA *V _{OUT} ≤ 1.7V, V _{IN} -V _{OUT} =1.2V, I _{OUT} =30mA	f=1kHz		70	dB	
			f=10kHz		65		
			f=10kHz (V _{OUT} ≥ 2.5V)		60		
V _{IN}	Input Voltage		2		6	V	
ΔV _{OUT} /ΔT _{opt}	Output Voltage Temperature Coefficient	I _{OUT} =30mA -40°C ≤ T _{opt} ≤ 85°C		±100		ppm /°C	
I _{SC}	Short Current Limit	V _{OUT} =0V		50		mA	
R _{PD}	CE Pull-down Resistance		0.7	2.0	5.0	MΩ	
V _{CEH}	CE Input Voltage "H"		1.5		6.0	V	
V _{CEL}	CE Input Voltage "L"		0		0.3	V	
en	Output Noise	BW=10Hz to 100kHz		30		μVrms	
R _{LOW}	On Resistance of Nch Tr. for Auto-discharge (Applied to B version)	V _{CE} =0V		50		Ω	

VR2

T_{opt}=25°C

Symbol	Item	Conditions	Min.	Typ.	Max.	Unit	
V _{OUT}	Output Voltage	V _{IN} -V _{OUT} =1.0V 1mA ≤ I _{OUT} ≤ 30mA	×0.98		×1.02	V	
I _{OUT}	Output Current	V _{IN} -V _{OUT} =1.0V	150			mA	
ΔV _{OUT} /ΔI _{OUT}	Load Regulation	V _{IN} -V _{OUT} =1.0V 1mA ≤ I _{OUT} ≤ 150mA		15	40	mV	
V _{DIF}	Dropout Voltage	I _{OUT} =150mA	V _{OUT} =1.5V		0.34	0.60	V
			V _{OUT} =1.6V		0.32	0.56	
			V _{OUT} =1.7V		0.31	0.53	
			1.8V ≤ V _{OUT} ≤ 2.0V		0.29	0.50	
			2.1V ≤ V _{OUT} ≤ 2.7V		0.26	0.44	
			2.8V ≤ V _{OUT} ≤ 4.0V		0.22	0.33	
I _{SS}	Supply Current	V _{IN} -V _{OUT} =1.0V		90	120	μA	
I _{standby}	Standby Current	V _{IN} -V _{OUT} =1.0V, V _{CE} =GND		0.1	1.0	μA	
ΔV _{OUT} /ΔV _{IN}	Line Regulation	I _{OUT} =30mA, V _{OUT} +0.5V ≤ V _{IN} ≤ 6.0V (V _{OUT} ≤ 1.6V: 2.2V ≤ V _{IN} ≤ 6.0V)		0.02	0.10	%/V	
RR	Ripple Rejection	sinusoidal Ripple 0.5Vp-p V _{IN} -V _{OUT} =1.0V, I _{OUT} =30mA *V _{OUT} ≤ 1.7V, V _{IN} -V _{OUT} =1.2V, I _{OUT} =30mA	f=1kHz		70		dB
			f=10kHz		65		
			f=10kHz (V _{OUT} ≥ 2.5V)		60		
V _{IN}	Input Voltage		2		6	V	
ΔV _{OUT} /ΔT _{opt}	Output Voltage Temperature Coefficient	I _{OUT} =30mA -40°C ≤ T _{opt} ≤ 85°C		±100		ppm /°C	
I _{SC}	Short Current Limit	V _{OUT} =0V		40		mA	
R _{PD}	CE Pull-down Resistance		0.7	2.0	5.0	MΩ	
V _{CEH}	CE Input Voltage "H"		1.5		6.0	V	
V _{CEL}	CE Input Voltage "L"		0		0.3	V	
en	Output Noise	BW=10Hz to 100kHz		30		μVrms	
R _{LOW}	On Resistance of Nch Tr. for Auto-discharge (Applied to B version)	V _{CE} =0V		50		Ω	

R5324x

VR3

 T_{opt}=25°C

Symbol	Item	Conditions	Min.	Typ.	Max.	Unit	
V _{OUT}	Output Voltage	V _{IN} -V _{OUT} =1.0V 1mA ≤ I _{OUT} ≤ 30mA	×0.98		×1.02	V	
I _{OUT}	Output Current	V _{IN} -V _{OUT} =1.0V	100			mA	
ΔV _{OUT} /ΔI _{OUT}	Load Regulation	V _{IN} -V _{OUT} =1.0V 1mA ≤ I _{OUT} ≤ 100mA		8	20	mV	
V _{DIF}	Dropout Voltage	I _{OUT} =100mA	V _{OUT} =1.5V		0.24	0.44	V
			V _{OUT} =1.6V		0.22	0.40	
			V _{OUT} =1.7V		0.21	0.38	
			1.8V ≤ V _{OUT} ≤ 2.0V		0.20	0.37	
			2.1V ≤ V _{OUT} ≤ 2.7V		0.18	0.33	
			2.8V ≤ V _{OUT} ≤ 4.0V		0.15	0.25	
I _{SS}	Supply Current	V _{IN} -V _{OUT} =1.0V		90	120	μA	
I _{standby}	Standby Current	V _{IN} -V _{OUT} =1.0V, V _{CE} =GND		0.1	1.0	μA	
ΔV _{OUT} /ΔV _{IN}	Line Regulation	I _{OUT} =30mA, V _{OUT} +0.5V ≤ V _{IN} ≤ 6.0V (V _{OUT} ≤ 1.6V: 2.2V ≤ V _{IN} ≤ 6.0V)		0.02	0.10	%/V	
RR	Ripple Rejection	sinusoidal Ripple 0.5Vp-p V _{IN} -V _{OUT} =1.0V, I _{OUT} =30mA *V _{OUT} ≤ 1.7V, V _{IN} -V _{OUT} =1.2V, I _{OUT} =30mA	f=1kHz		70		dB
			f=10kHz		65		
			f=10kHz (V _{OUT} ≥ 2.5V)		60		
V _{IN}	Input Voltage		2		6	V	
ΔV _{OUT} /ΔT _{opt}	Output Voltage Temperature Coefficient	I _{OUT} =30mA -40°C ≤ T _{opt} ≤ 85°C		±100		ppm /°C	
I _{SC}	Short Current Limit	V _{OUT} =0V		40		mA	
R _{PD}	CE Pull-down Resistance		0.7	2.0	5.0	MΩ	
V _{CEH}	CE Input Voltage "H"		1.5		6.0	V	
V _{CEL}	CE Input Voltage "L"		0		0.3	V	
en	Output Noise	BW=10Hz to 100kHz		30		μVrms	
R _{LOW}	On Resistance of Nch Tr. for Auto-discharge (Applied to B version)	V _{CE} =0V		50		Ω	

OPERATION

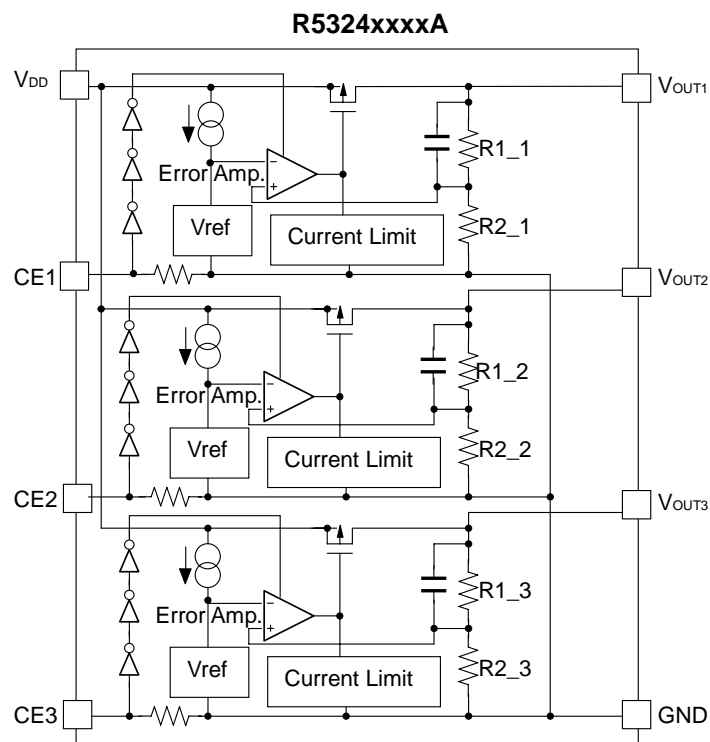

Fluctuation of each regulator's output voltage, or V_{OUT1} , V_{OUT2} , V_{OUT3} is detected individually. Then it is put back to an error amplifier through feedback resistors, or $R1_1$, $R2_1$, $R1_2$, $R2_2$, $R1_3$, $R2_3$ and compared with a reference voltage and compensated for the result and make a constant voltage.

In each regulator, short protection is made with a current limit circuit and stand-by mode is available by a chip enable circuit.

TYPICAL APPLICATION

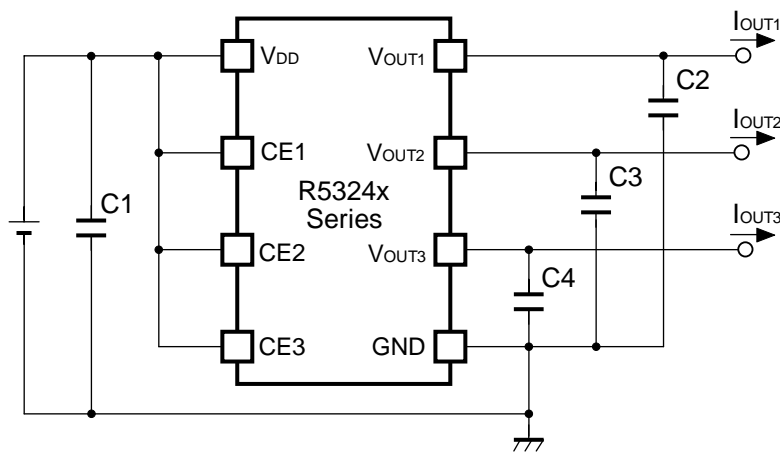

(External Components)

Output Capacitor : Ceramic 1.0 μ F or more

TECHNICAL NOTES

When using these ICs, consider the following points:

Phase Compensation

In these ICs, phase compensation is made for securing stable operation even if the load current is varied. For this purpose, use a capacitor C2, C3 and C4 with 1.0 μ F or more.

If a tantalum capacitor is used, and its ESR (Equivalent Series Resistance) of C2, C3 and C4 is large, the loop oscillation may result. Because of this, select C2, C3 and C4 carefully considering its frequency characteristics.

PCB Layout

Make V_{DD} and GND lines sufficient. If their impedance is high, noise pickup or unstable operation may result. Connect a capacitor C1 with a capacitance value as much as 1.0 μ F or more between V_{DD} and GND pin, and as close as possible to the pins.

Set external components, especially the output capacitor C2, C3 and C4 as close as possible to the ICs, and make wiring as short as possible.

TEST CIRCUIT

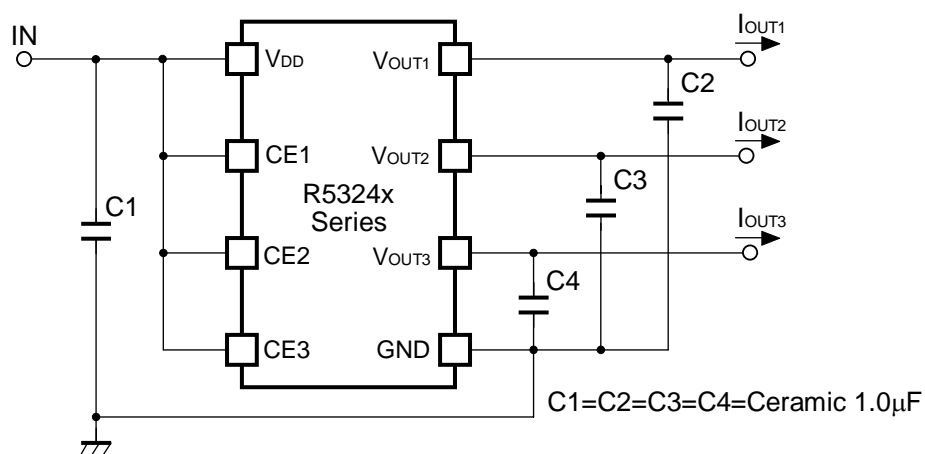

Basic Test Circuit

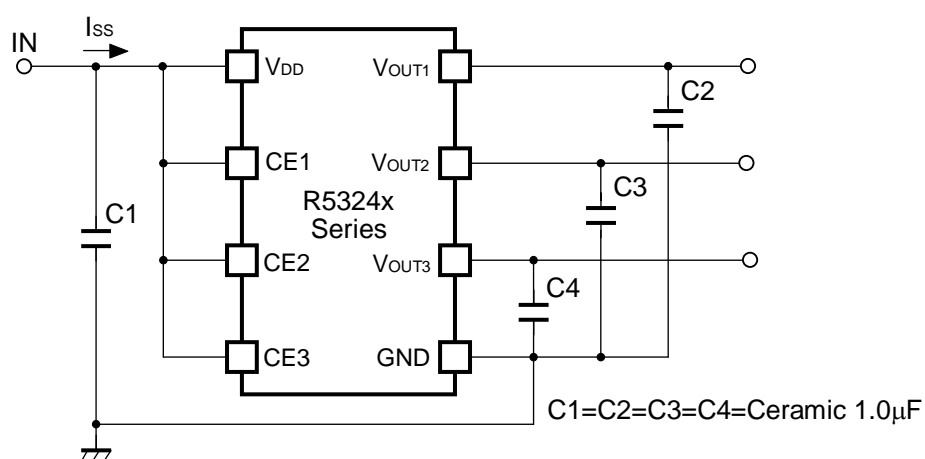

Test Circuit for Supply Current

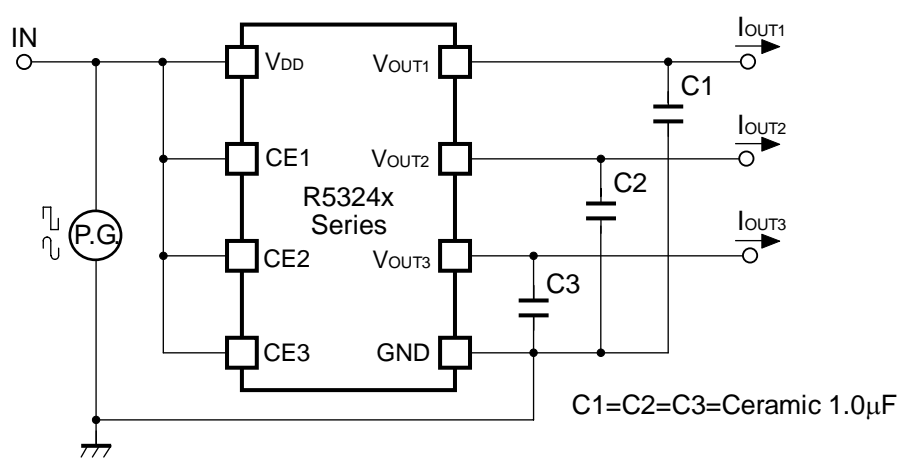

Test Circuit for Ripple Rejection, Input Transient Response

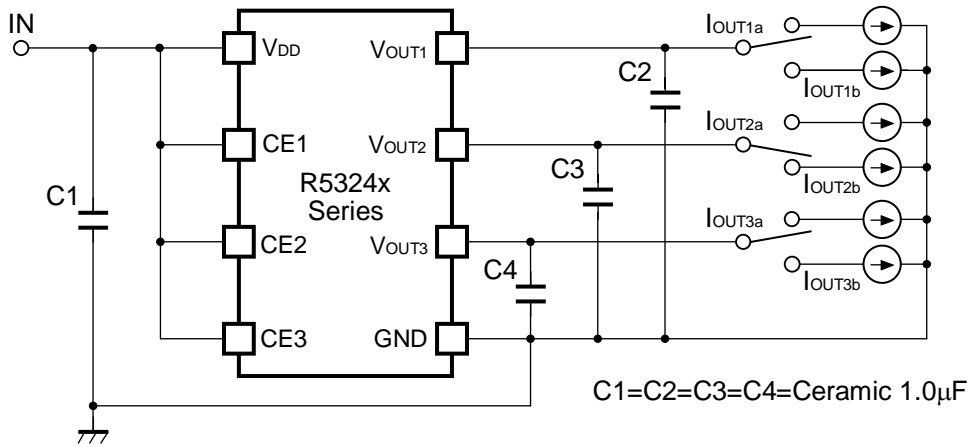

Test Circuit for Load Transient Response

TYPICAL CHARACTERISTICS

1) Output Voltage vs. Output Current (Topt=25°C)

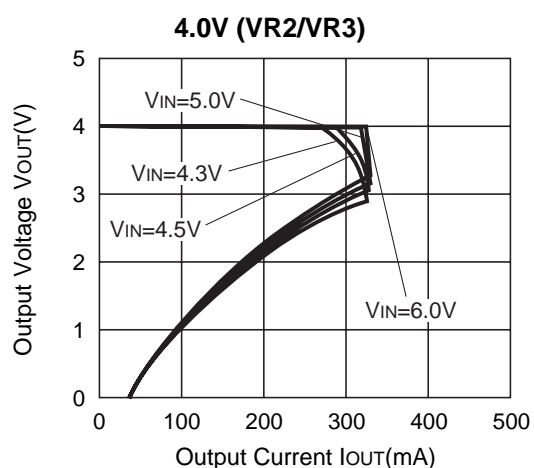
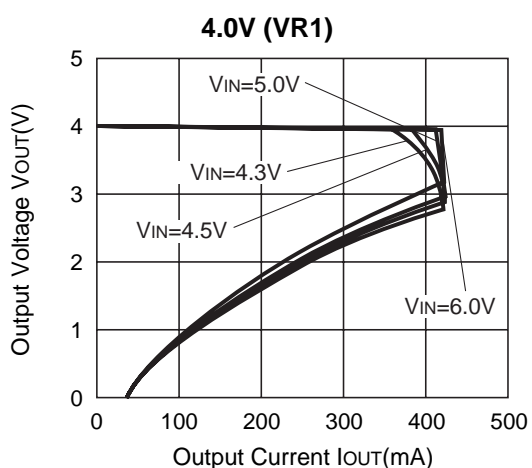
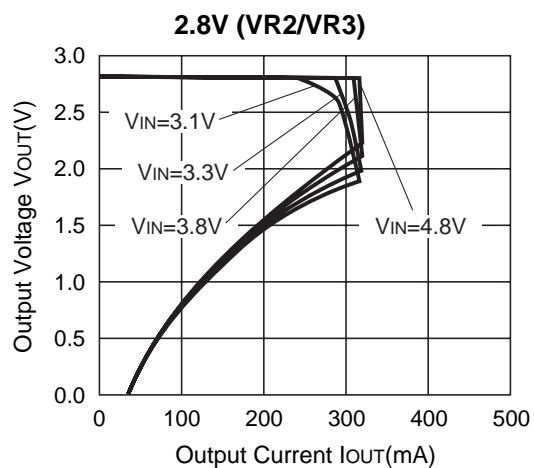
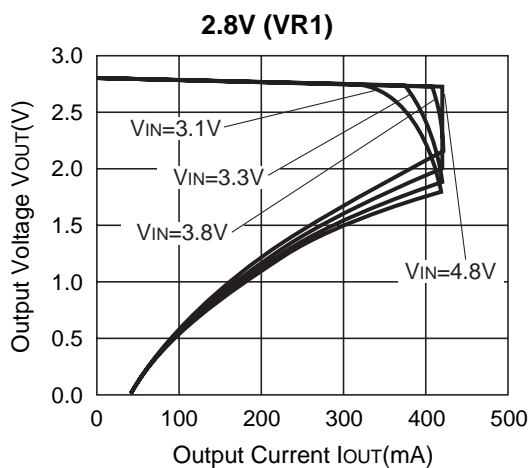
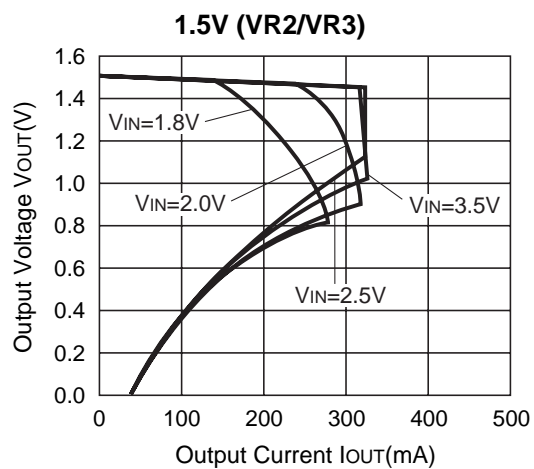
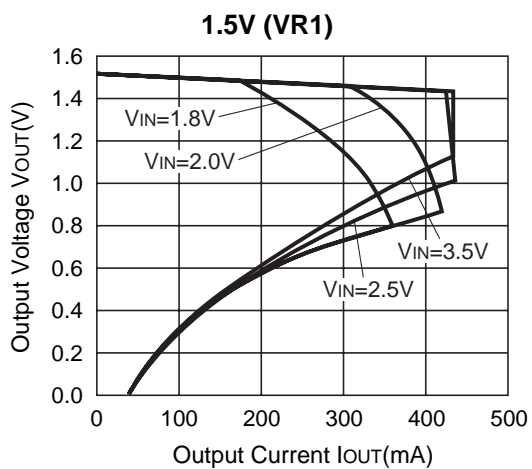

2) Output Voltage vs. Input Voltage ($T_{opt}=25^{\circ}C$)

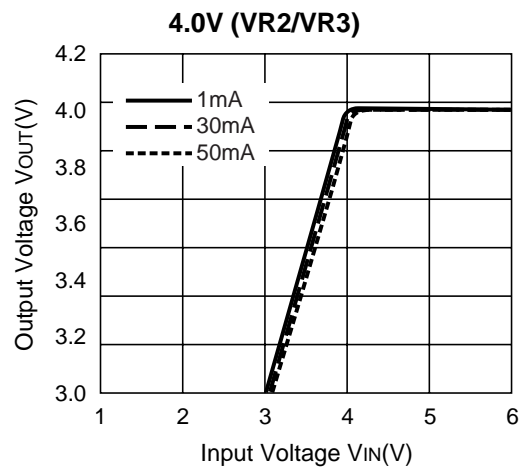
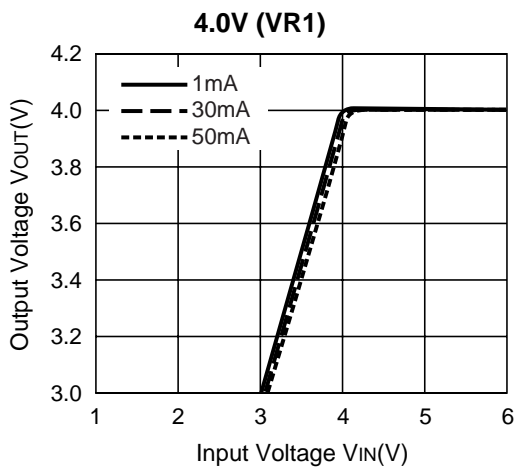
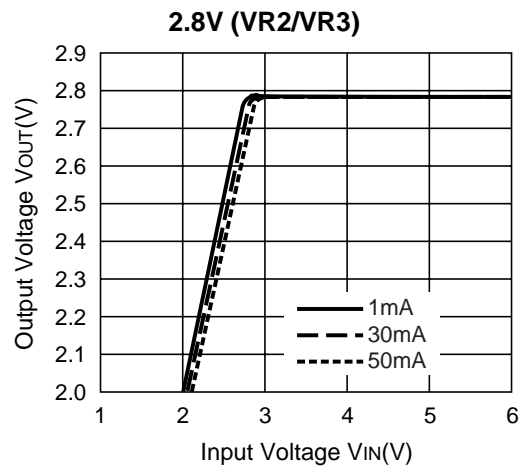
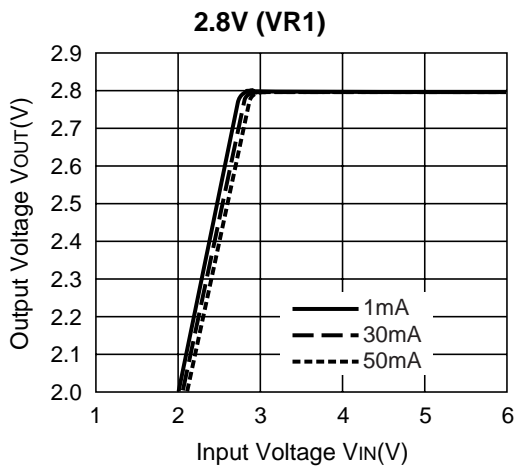
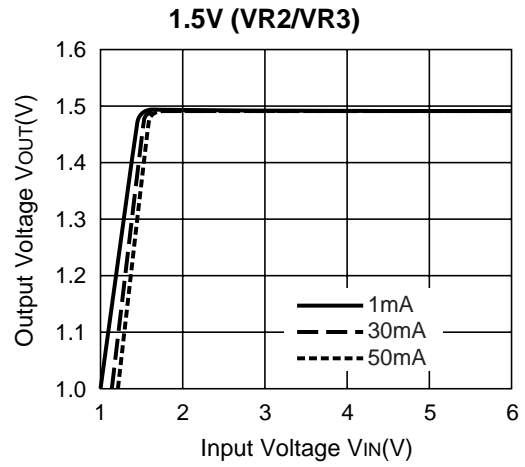
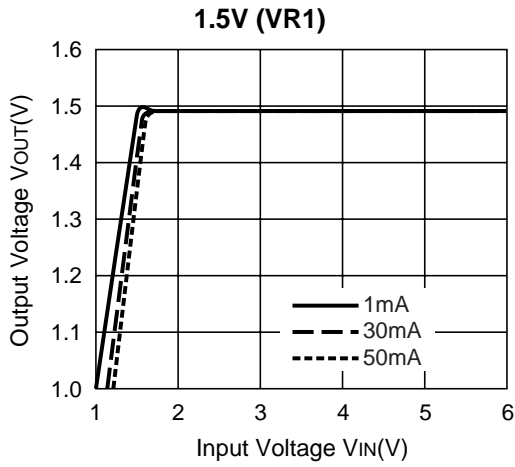

3) Dropout Voltage vs. Output Current

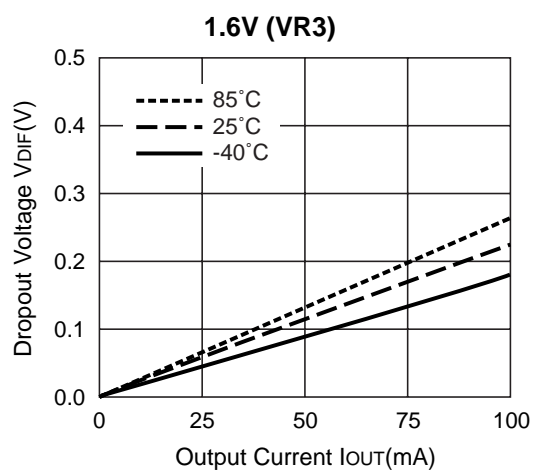
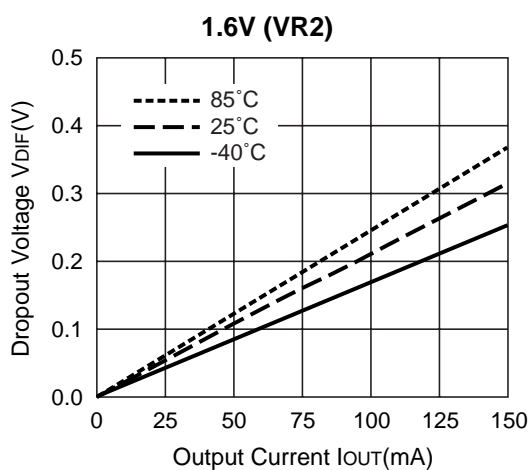
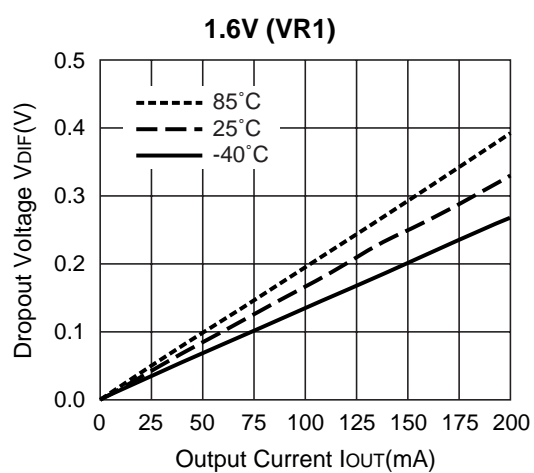
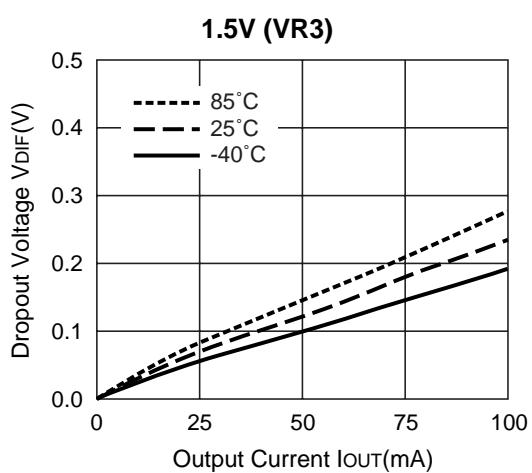
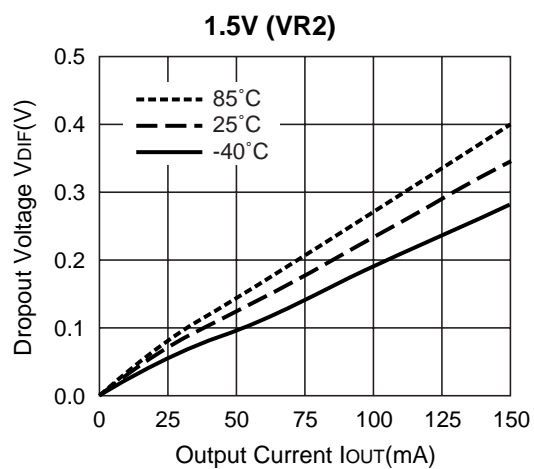
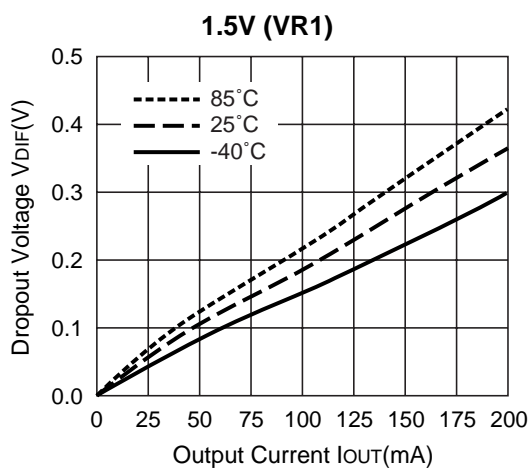

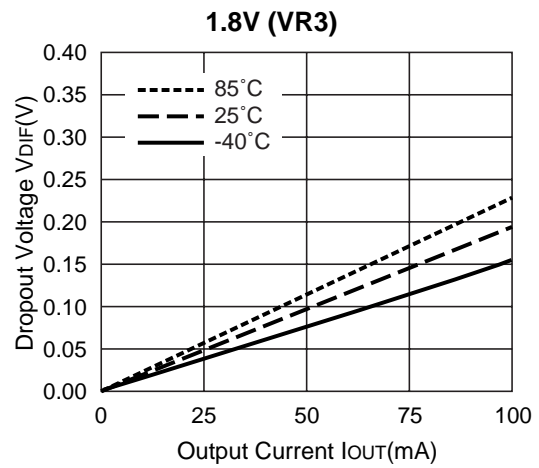
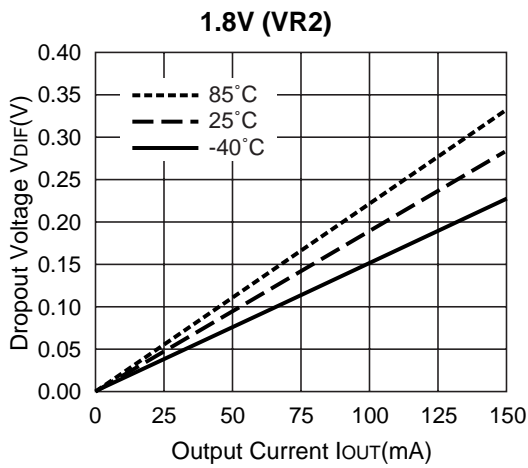
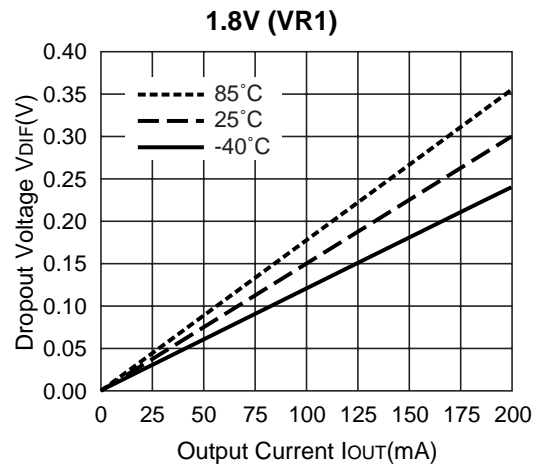
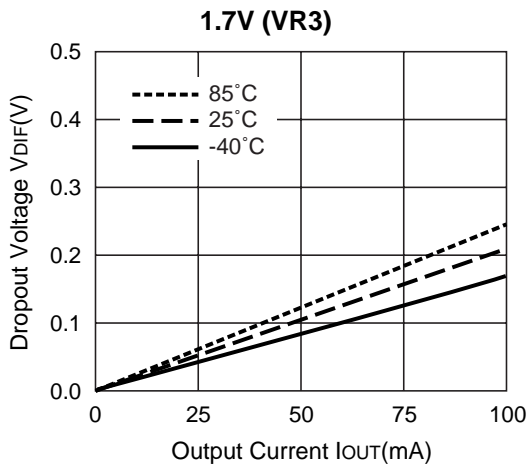
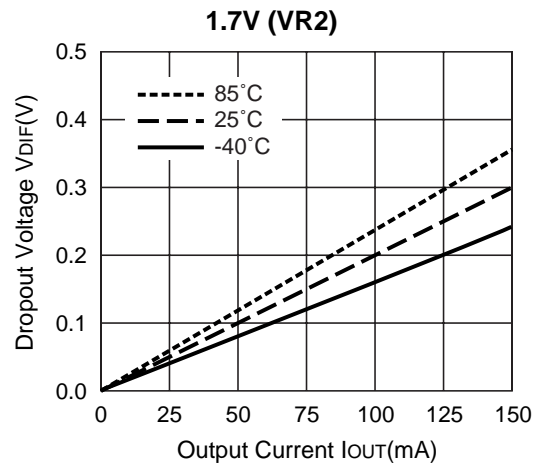
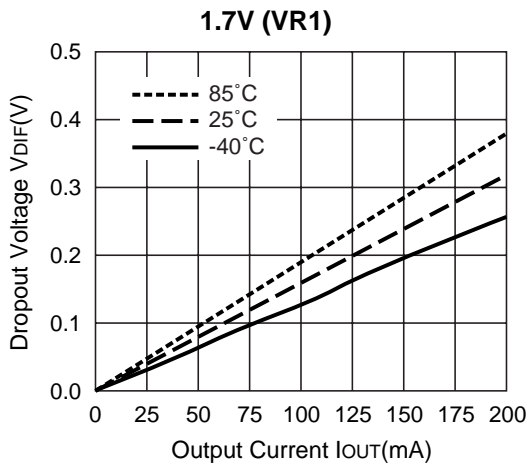

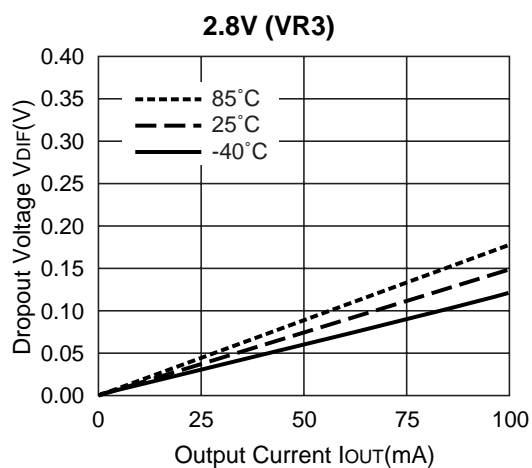
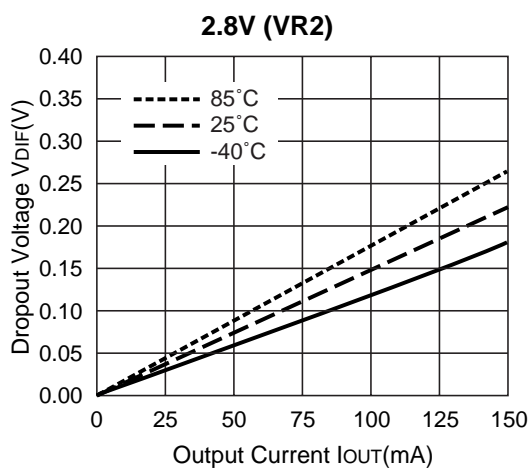
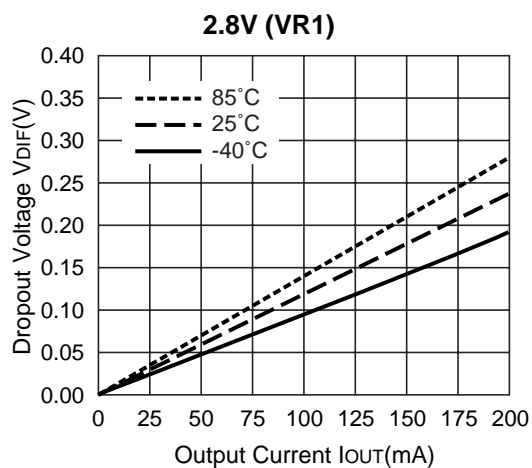
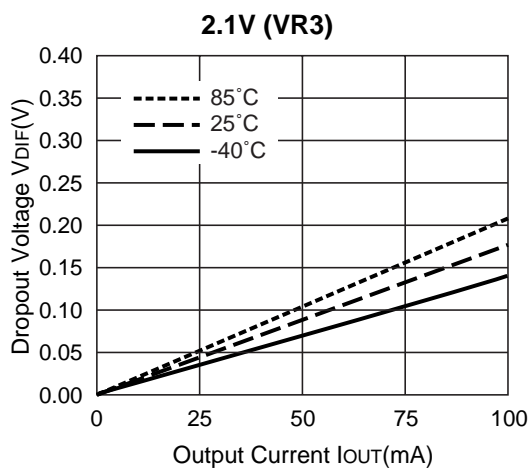
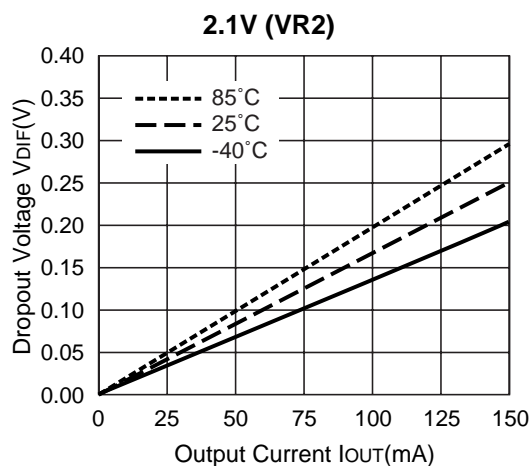
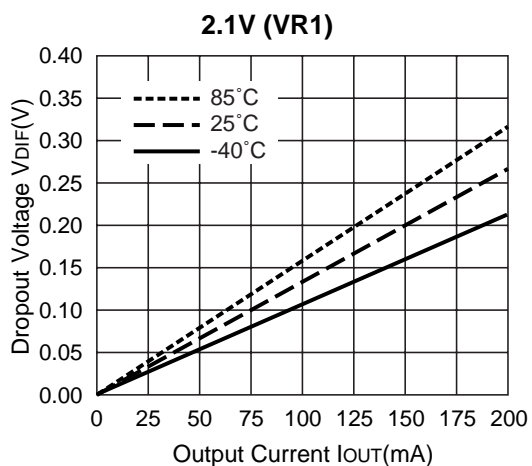

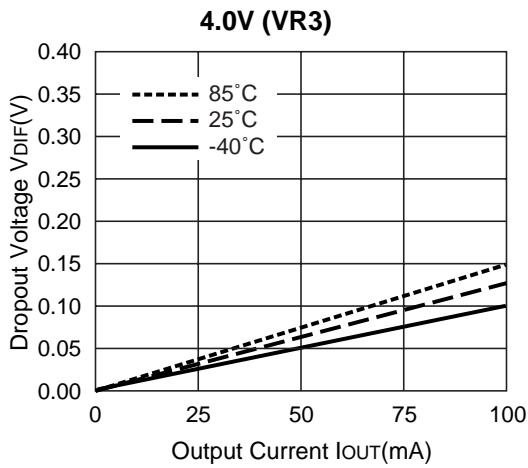
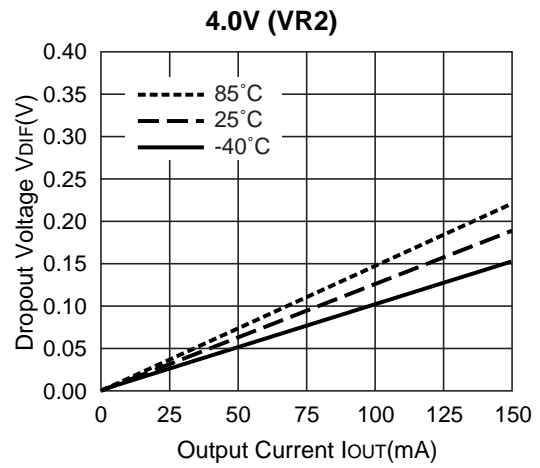
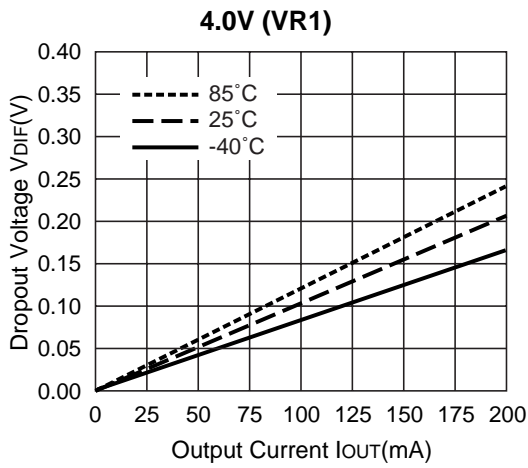

4) Output Voltage vs. Temperature ($I_{OUT}=30mA$)

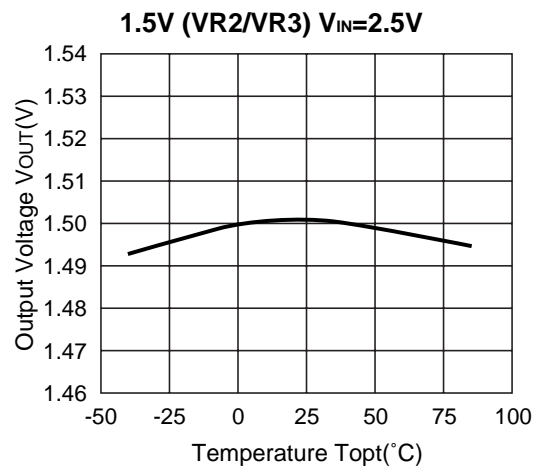
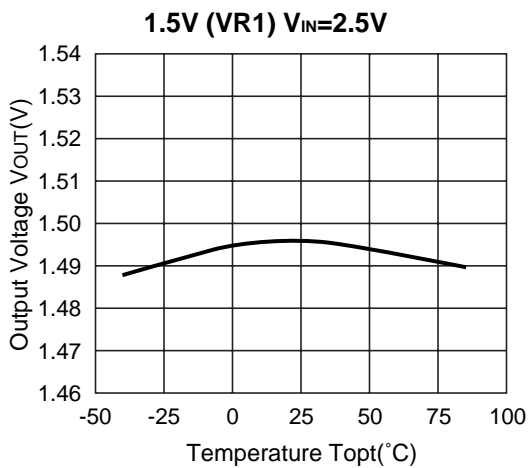

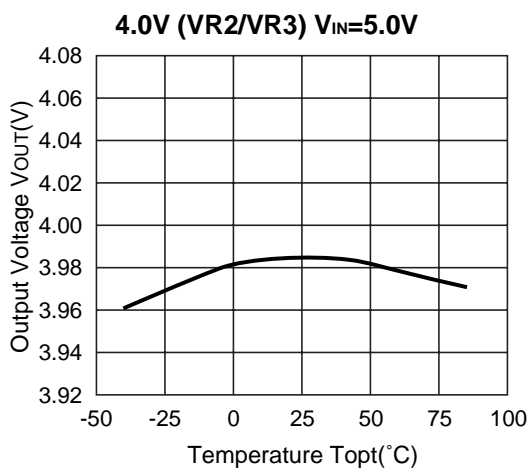
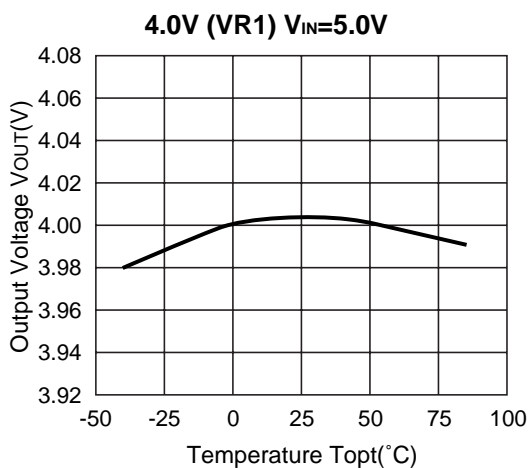
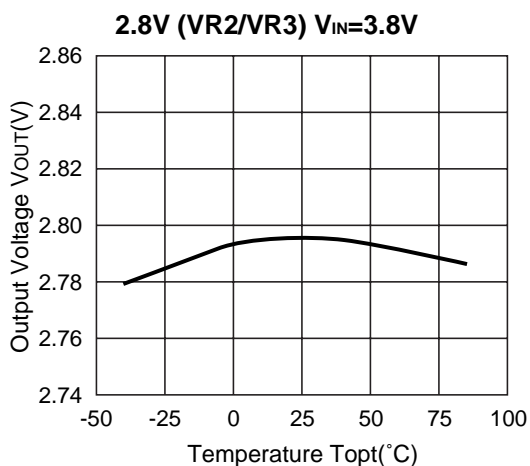
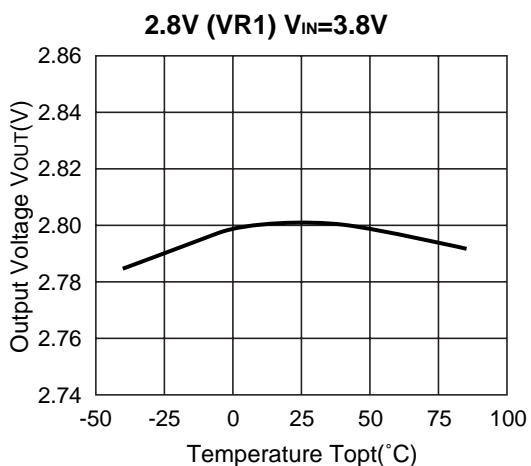

5) Supply Current vs. Input Voltage ($T_{opt}=25^{\circ}C$)

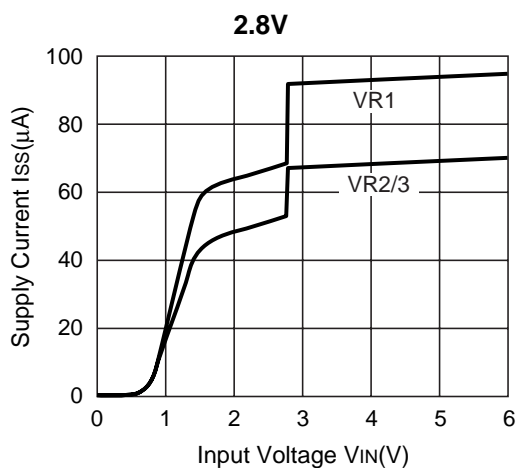
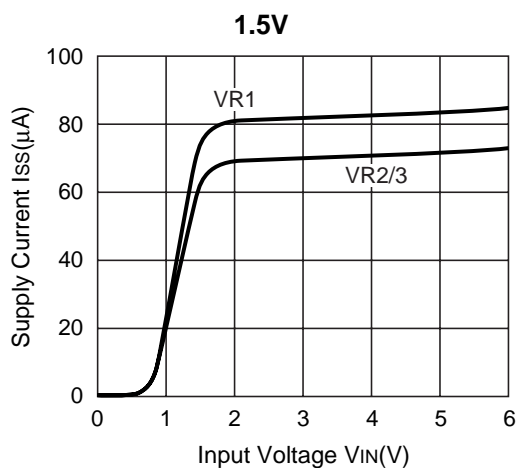

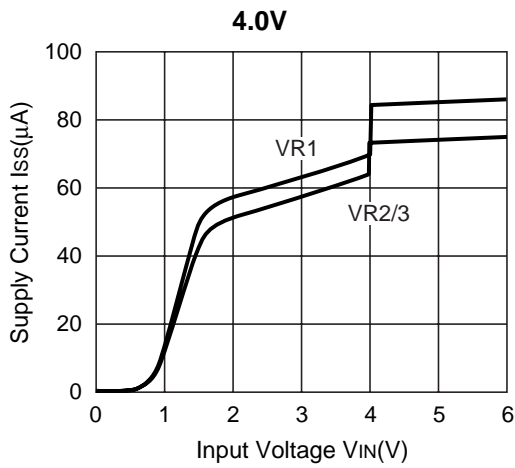

6) Supply Current vs. Temperature

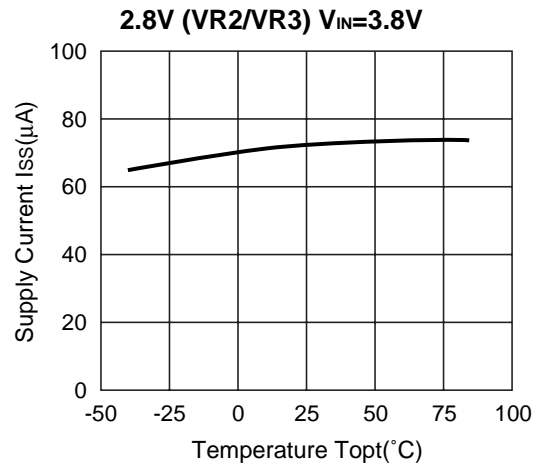
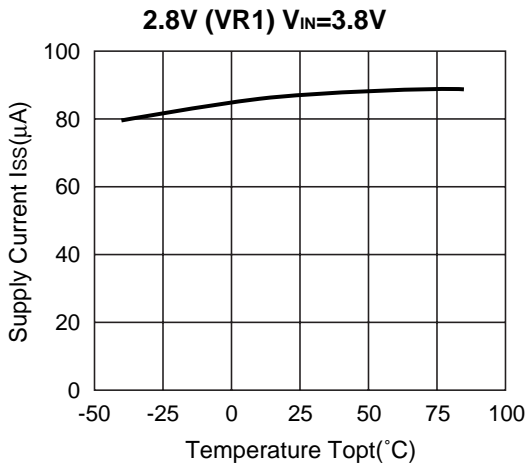
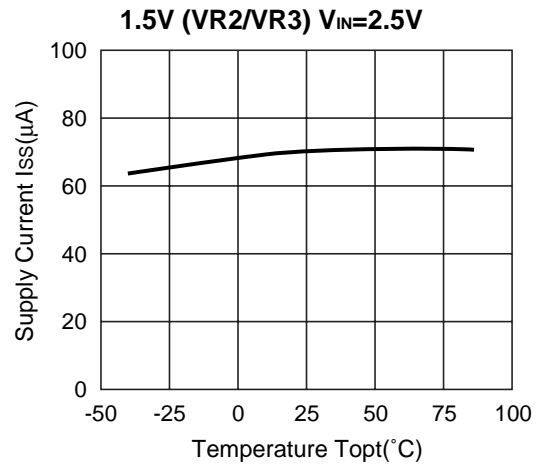
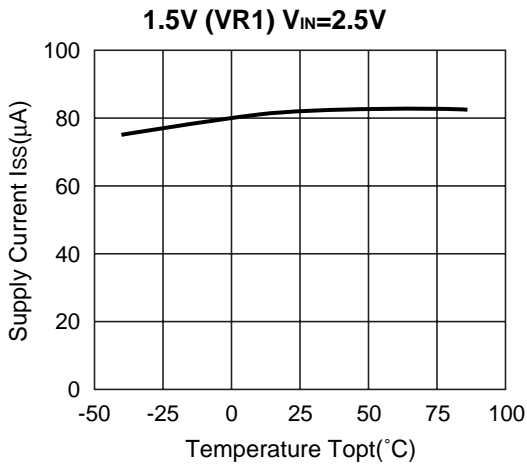

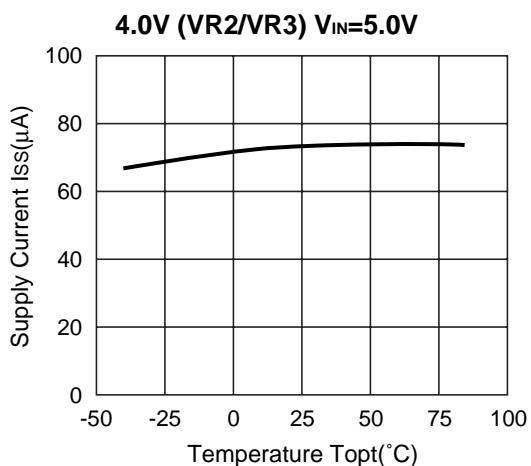
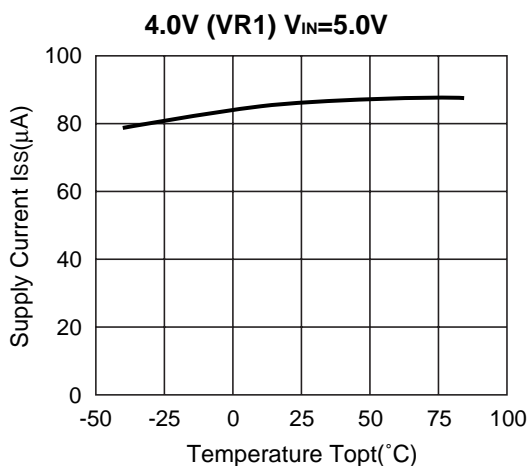

7) Dropout Voltage vs. Set Output Voltage (T_{opt}=25°C)

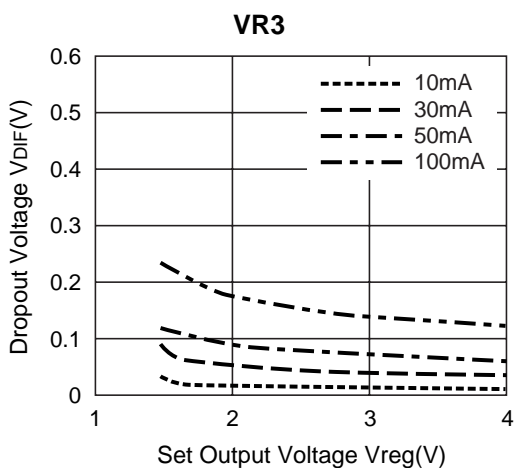
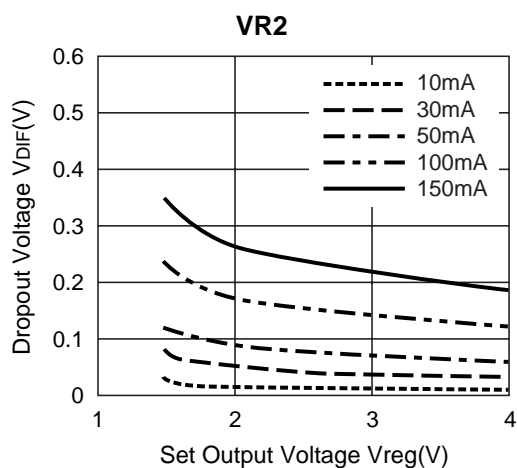
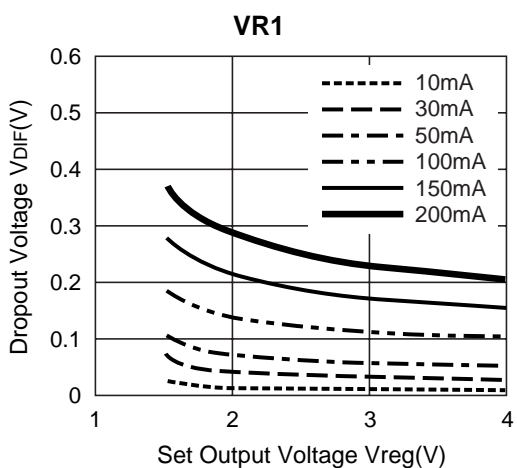

8) Ripple Rejection vs. Frequency ($T_{opt}=25^{\circ}C$, $C_{OUT}=\text{Ceramic } 1.0\mu F$)

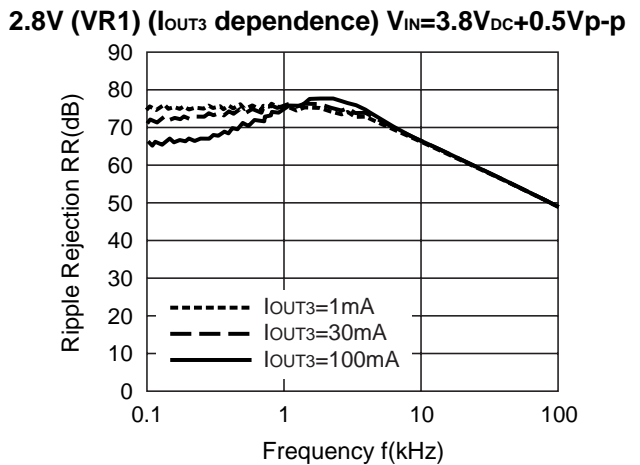
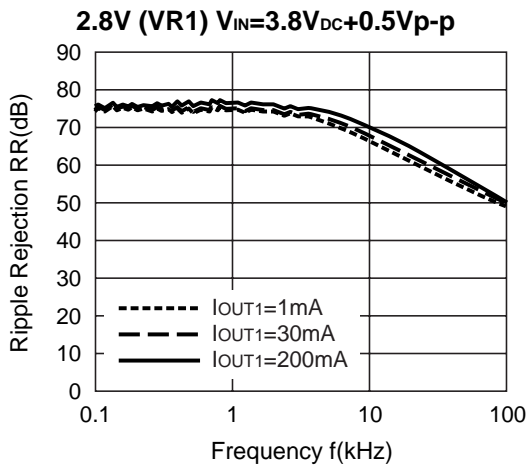
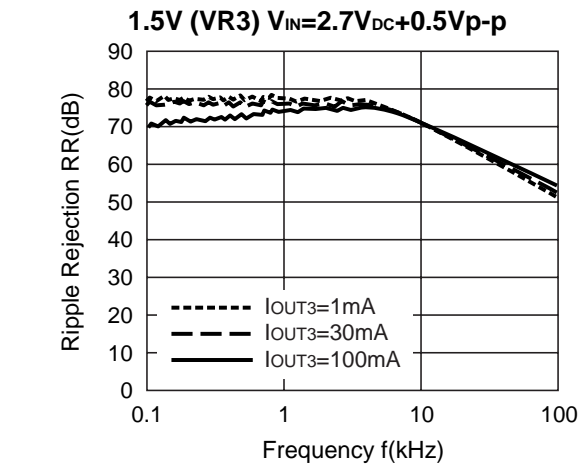
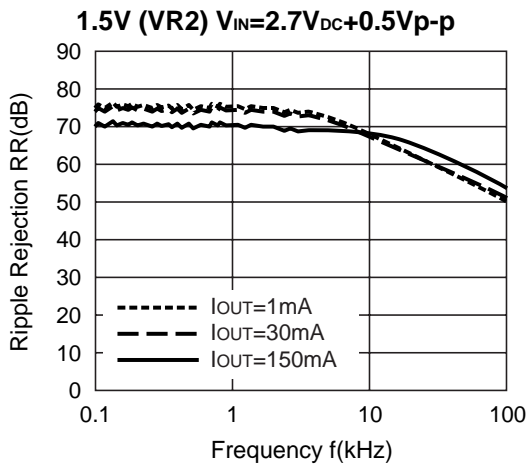
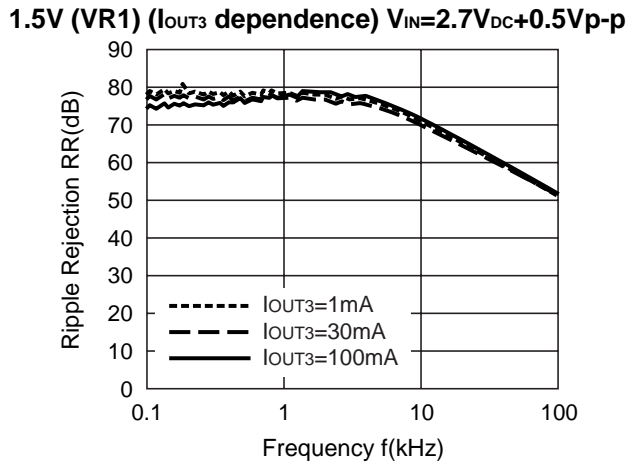
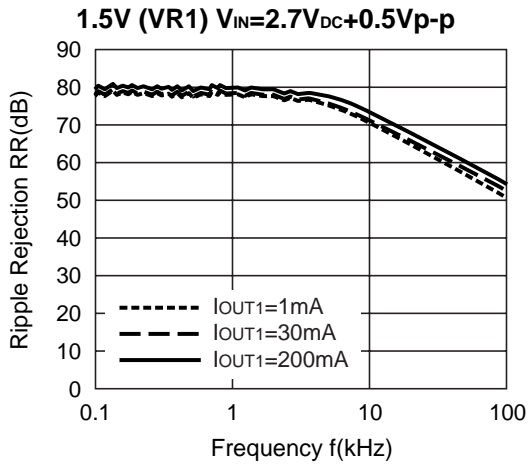

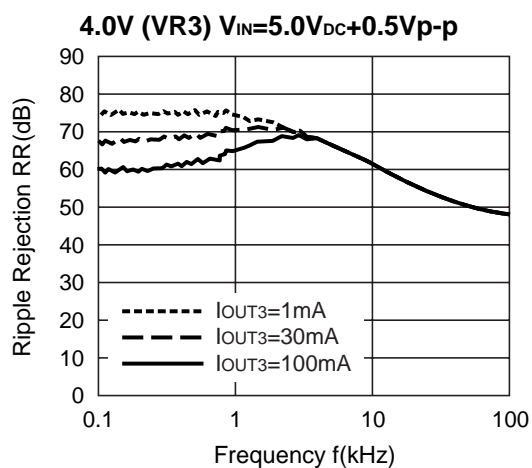
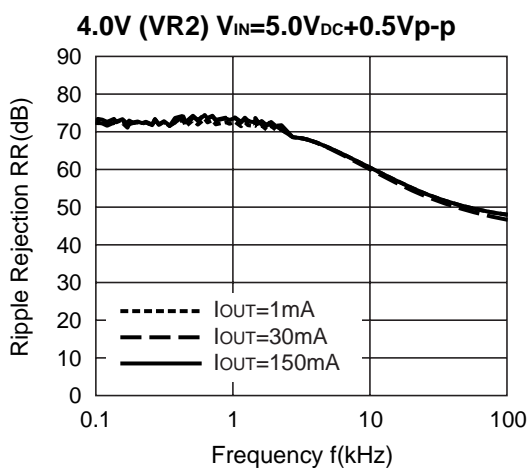
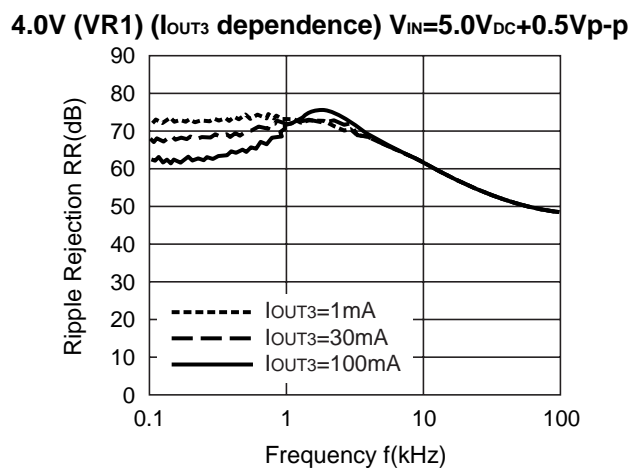
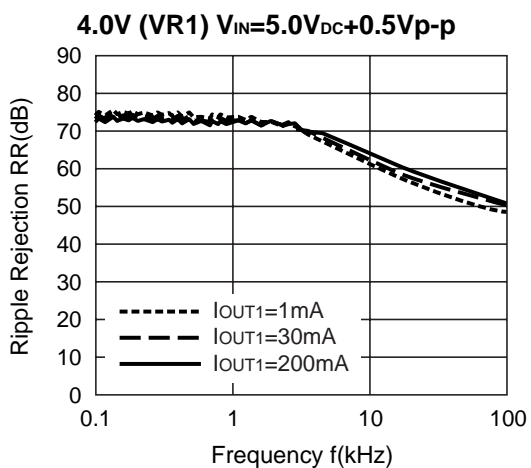
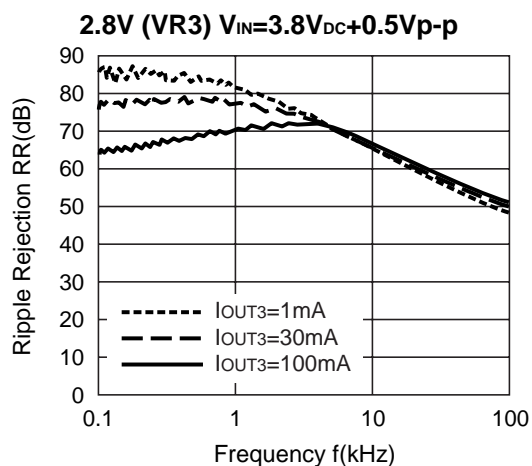
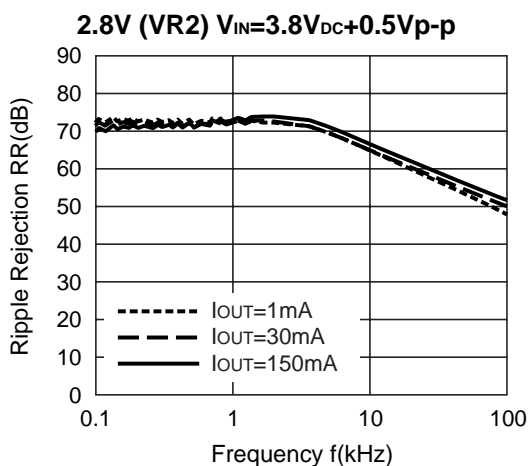

9) Ripple Rejection vs. DC Input Bias (T_{opt}=25°C, C_{OUT}=1.0μF)

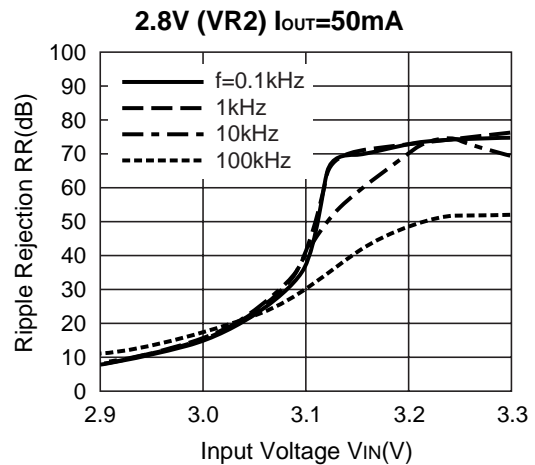
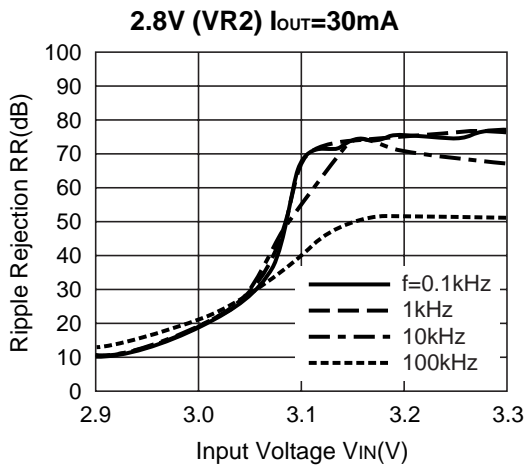
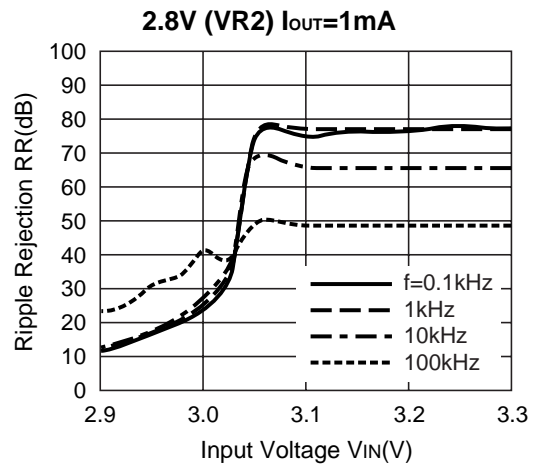
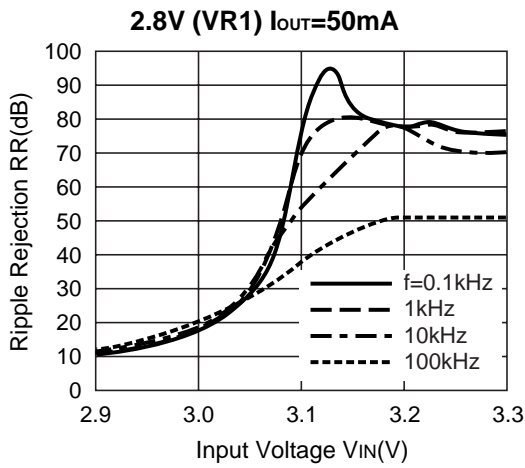
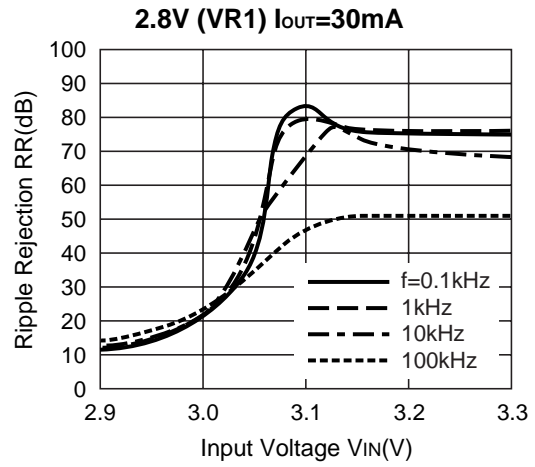
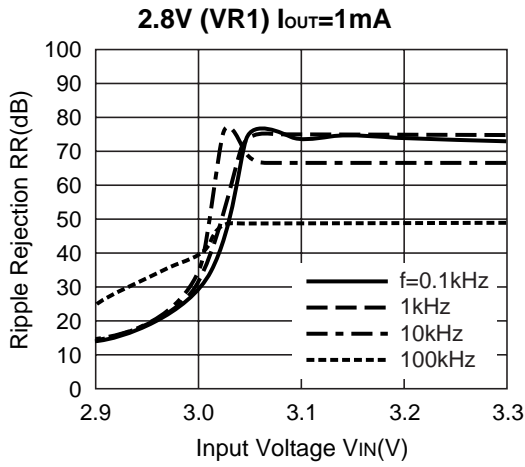

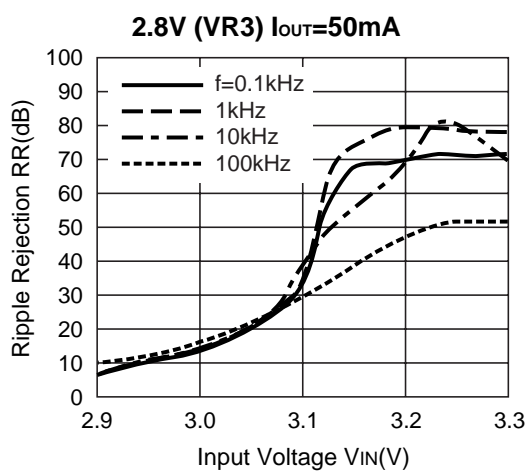
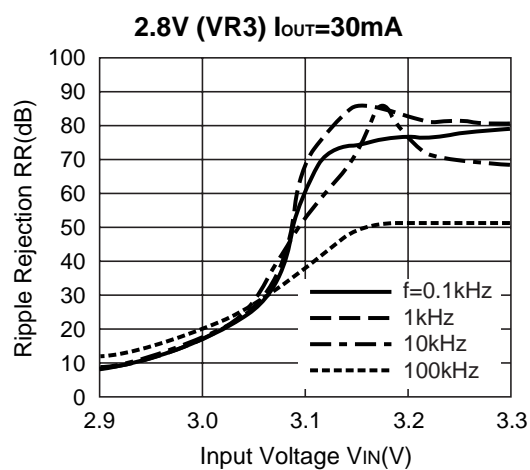
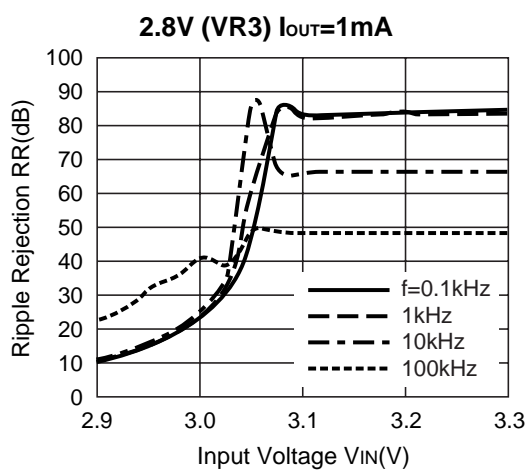

10) Line Transient Response ($I_{OUT}=30mA$, $C_{IN}=none$, $t_r=t_f=5\mu s$, $C_{OUT}=Ceramic\ 1\mu F$)

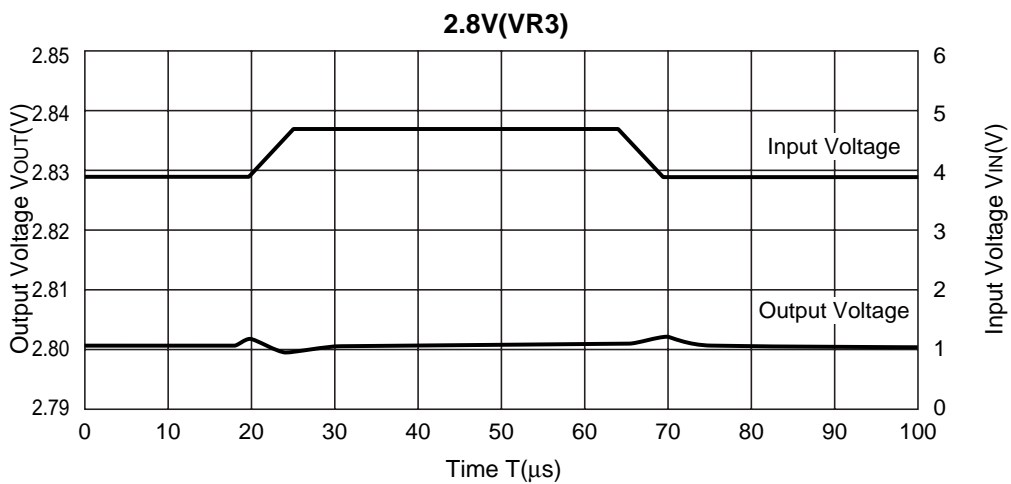
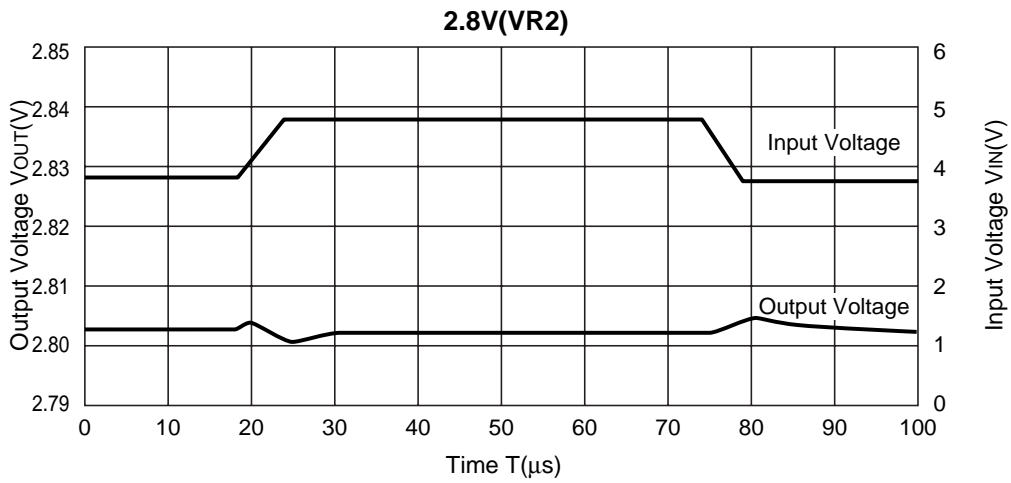
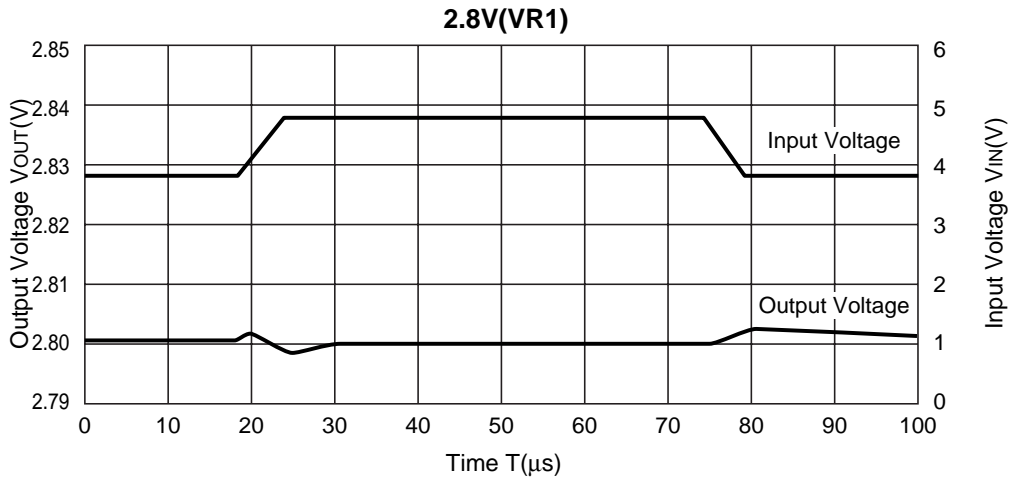

11) Load Transient Response (C_{IN} =Ceramic $1.0\mu F$, C_{OUT} =Ceramic $1.0\mu F$)

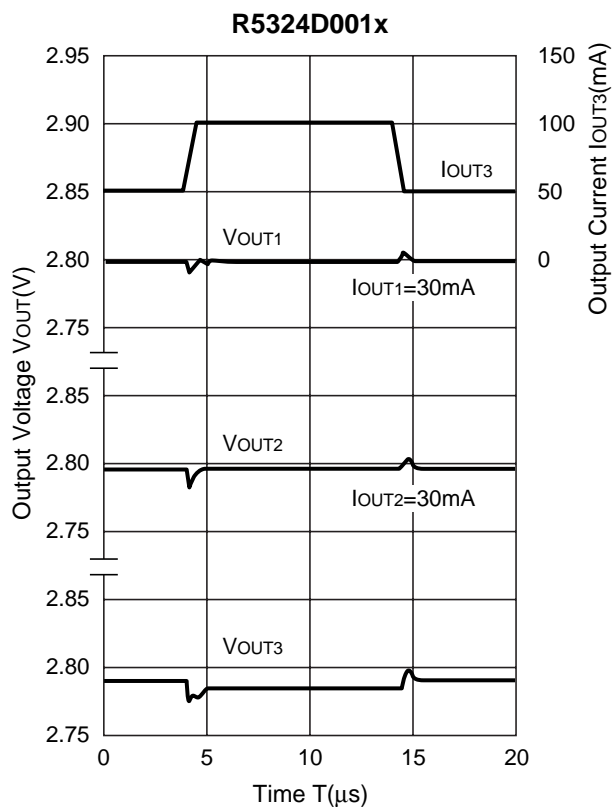
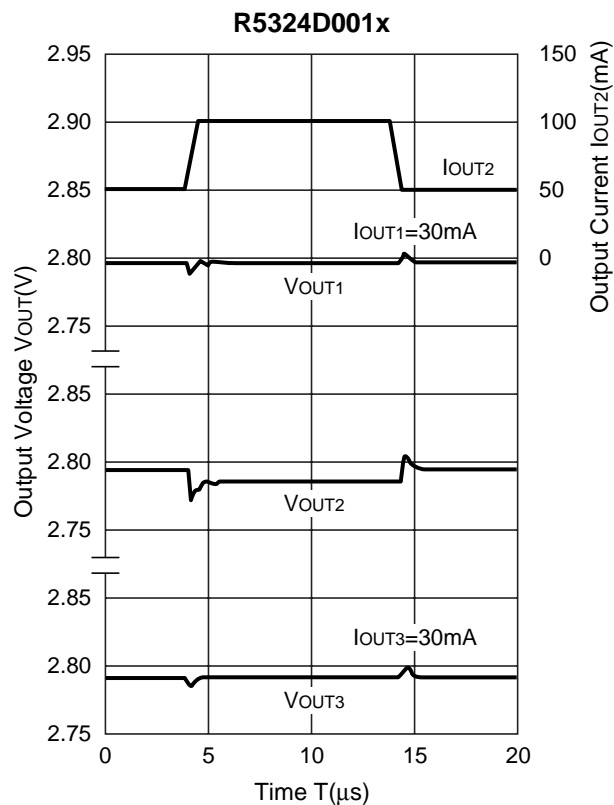
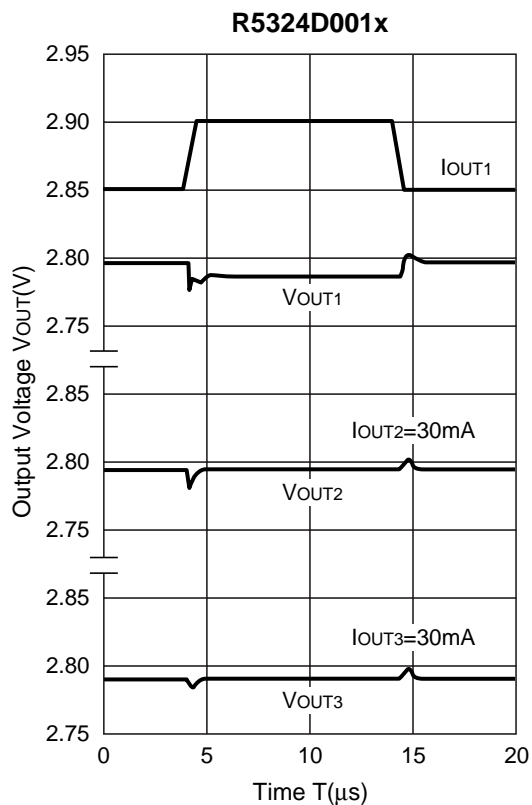

ESR vs. Output Current

When using these ICs, consider the following points:

The relations between I_{OUT} (Output Current) and ESR of an output capacitor are shown below.

The conditions when the white noise level is under $40\mu\text{V}$ (Avg.) are marked as the hatched area in the graph.

Measurement conditions

Frequency Band : 10Hz to 2MHz

Temperature : -40°C to 85°C

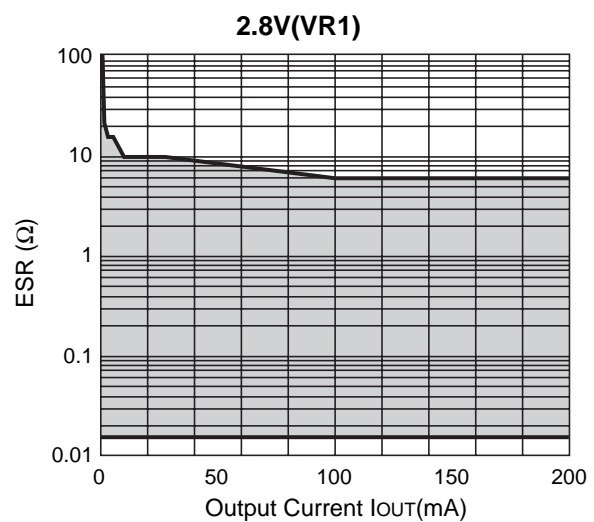
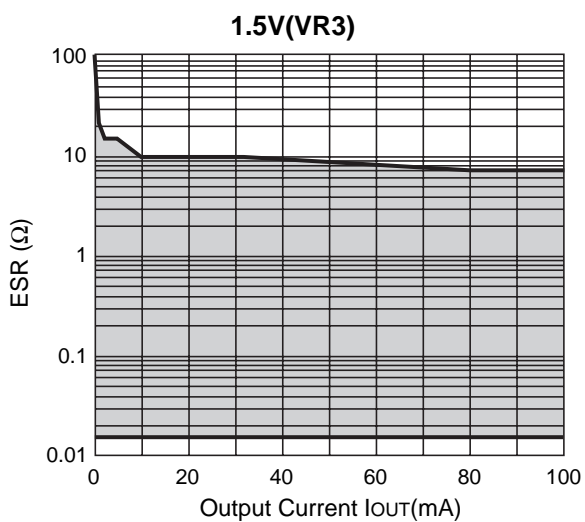
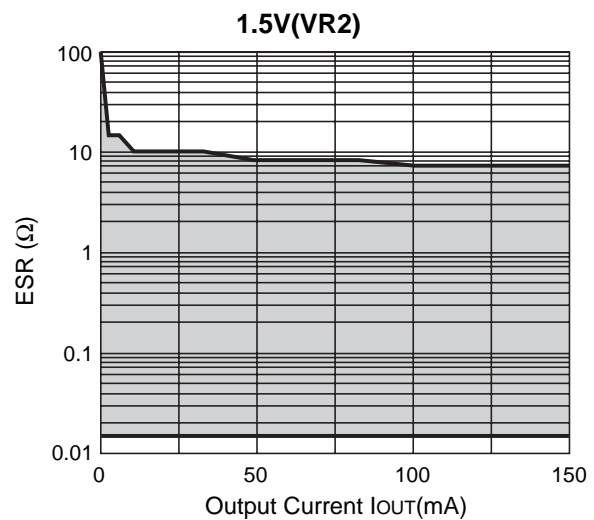
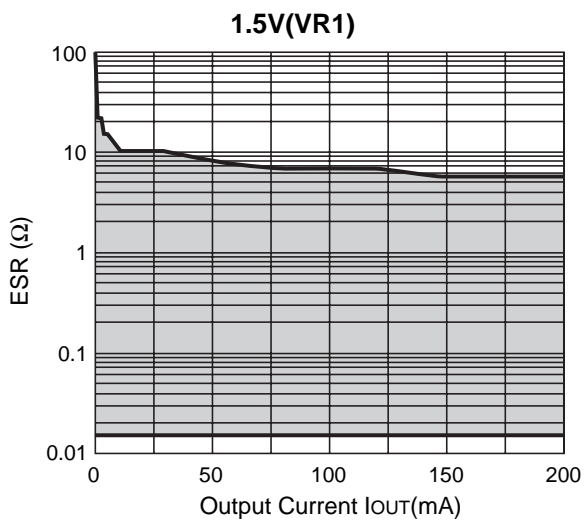

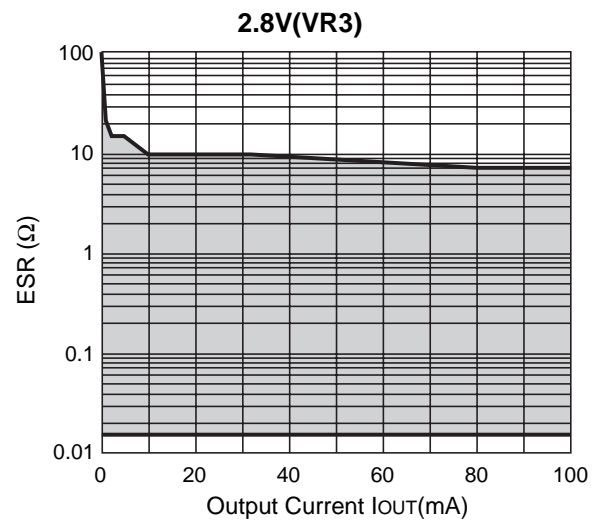
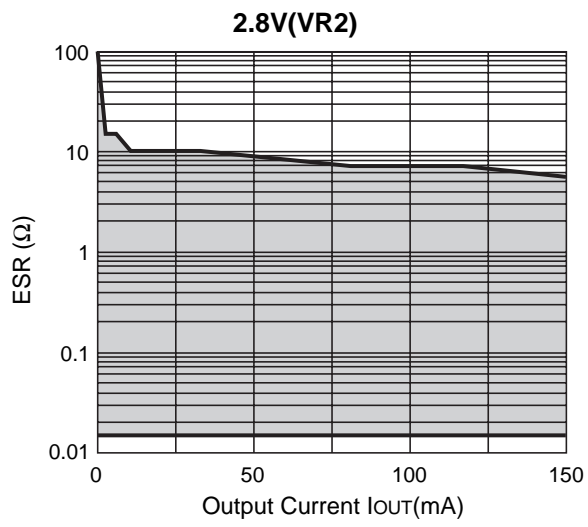



1. The products and the product specifications described in this document are subject to change or discontinuation of production without notice for reasons such as improvement. Therefore, before deciding to use the products, please refer to Ricoh sales representatives for the latest information thereon.
2. The materials in this document may not be copied or otherwise reproduced in whole or in part without prior written consent of Ricoh.
3. Please be sure to take any necessary formalities under relevant laws or regulations before exporting or otherwise taking out of your country the products or the technical information described herein.
4. The technical information described in this document shows typical characteristics of and example application circuits for the products. The release of such information is not to be construed as a warranty of or a grant of license under Ricoh's or any third party's intellectual property rights or any other rights.
5. The products listed in this document are intended and designed for use as general electronic components in standard applications (office equipment, telecommunication equipment, measuring instruments, consumer electronic products, amusement equipment etc.). Those customers intending to use a product in an application requiring extreme quality and reliability, for example, in a highly specific application where the failure or misoperation of the product could result in human injury or death (aircraft, spacevehicle, nuclear reactor control system, traffic control system, automotive and transportation equipment, combustion equipment, safety devices, life support system etc.) should first contact us.
6. We are making our continuous effort to improve the quality and reliability of our products, but semiconductor products are likely to fail with certain probability. In order to prevent any injury to persons or damages to property resulting from such failure, customers should be careful enough to incorporate safety measures in their design, such as redundancy feature, firecontainment feature and fail-safe feature. We do not assume any liability or responsibility for any loss or damage arising from misuse or inappropriate use of the products.
7. Anti-radiation design is not implemented in the products described in this document.
8. Please contact Ricoh sales representatives should you have any questions or comments concerning the products or the technical information.



For the conservation of the global environment, Ricoh is advancing the decrease of the negative environmental impact material.
After Apr. 1, 2006, we will ship out the lead free products only. Thus, all products that will be shipped from now on comply with RoHS Directive.
Basically after Apr. 1, 2012, we will ship out the Power Management ICs of the Halogen Free products only. (Ricoh Halogen Free products are also Antimony Free.)

RICOH RICOH COMPANY, LTD. Electronic Devices Company

<http://www.ricoh.com/LSI/>

RICOH COMPANY, LTD.

Electronic Devices Company

● Higashi-Shinagawa Office (International Sales)

3-32-3, Higashi-Shinagawa, Shinagawa-ku, Tokyo 140-8655, Japan
Phone: +81-3-5479-2857 Fax: +81-3-5479-0502

RICOH EUROPE (NETHERLANDS) B.V.

● Semiconductor Support Centre

"Nieuw Kronenburg" Prof. W.H. Keesomlaan 1, 1183 DJ, Amstelveen, The Netherlands
P.O.Box 114, 1180 AC Amstelveen
Phone: +31-20-5474-309 Fax: +31-20-5474-791

RICOH ELECTRONIC DEVICES KOREA Co., Ltd.

11 floor, Haesung 1 building, 942, Daechidong, Gangnamgu, Seoul, Korea
Phone: +82-2-2135-5700 Fax: +82-2-2135-5705

RICOH ELECTRONIC DEVICES SHANGHAI Co., Ltd.

Room403, No.2 Building, 690#Bi Bo Road, Pu Dong New district, Shanghai 201203,
People's Republic of China
Phone: +86-21-5027-3200 Fax: +86-21-5027-3299

RICOH COMPANY, LTD.

Electronic Devices Company

● Taipei office

Room109, 10F-1, No.51, Hengyang Rd., Taipei City, Taiwan (R.O.C.)
Phone: +886-2-2313-1621/1622 Fax: +886-2-2313-1623