150mA Voltage Regulator (Wide Input Voltage Range)

NO.EA-100-120521

OUTLINE

The R1154x series are CMOS-based voltage regulator (VR) ICs. The R1154x has features of high output voltage accuracy and ultra-low supply current. A peak current limit circuit, a short current limit circuit, and a thermal shutdown circuit are built in the R1154x series.

The regulator output voltage is fixed in the R1154xxxB, while adjustable type is the R1154x001C. Output voltage accuracy is $\pm 2.0\%$.

Since the packages for these ICs are DFN1616-6, SOT-23-5, and SOT-89-5, high density mounting of the ICs on boards is possible.

FEATURES

- Supply CurrentTyp. 5.0 μ A
- Standby CurrentTyp. 0.1 μ A
- Output Voltage Accuracy..... $\pm 2.0\%$
- Wide Output Voltage Range2.5V to 12.0V (0.1V steps) (xxxB)
adjustable in the range of 2.5V to V_{IN} or 24.0V (001C)
(For other voltages, please refer to MARK INFORMATION.)
- Input VoltageMax. 24.0V
- Output CurrentMin. 140mA ($V_{IN}=V_{OUT}+2.0V$, 2.5V Output type)
Min. 150mA ($V_{IN}=V_{OUT}+2.0V$, 3.0V Output type)
- PackageDFN1616-6, SOT-23-5, SOT-89-5
- Built-in Peak Current Limit Circuit
- Built-in Short Current Limit Circuit
- Built-in Thermal Shutdown Circuit

APPLICATIONS

- Power source for home appliances such as refrigerators, rice cookers, Electronic water warmers, etc.
- Power source for car audio equipment, car navigation system, and ETC system.
- Power source for notebook PCs, digital TVs, cordless phones, and LAN system.
- Power source for copiers, printers, facsimiles, and scanners.

BLOCK DIAGRAMS

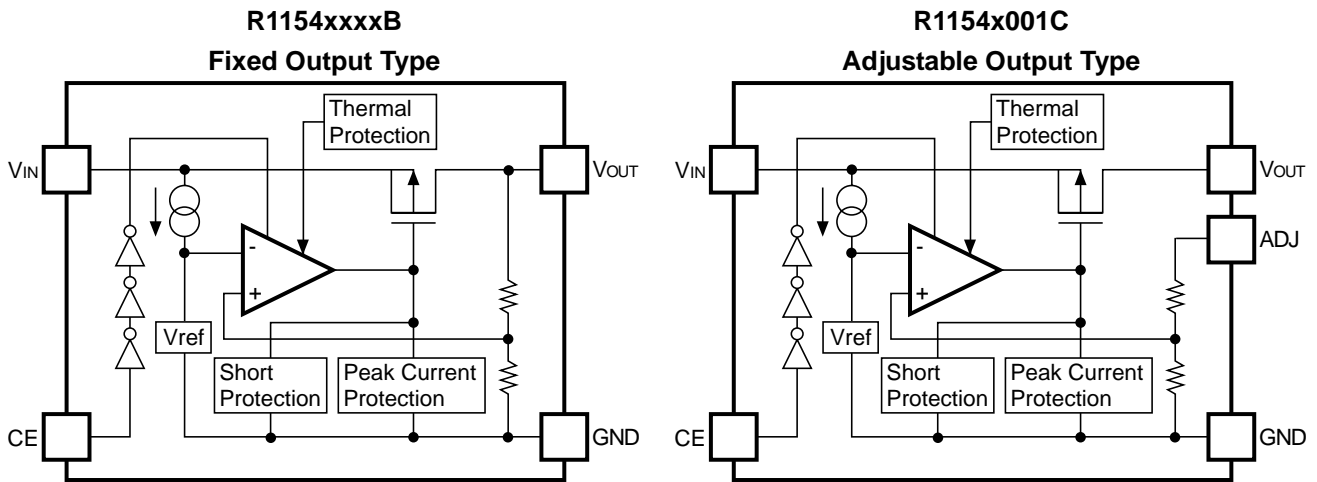

SELECTION GUIDE

The output voltage can be selected at the user's request.

Product Name	Package	Quantity per Reel	Pb Free	Halogen Free
R1154Lxxx*-TR	DFN1616-6	5,000 pcs	Yes	Yes
R1154Nxxx*-TR-FE	SOT-23-5	3,000 pcs	Yes	Yes
R1154Hxxx*-T1-FE	SOT-89-5	1,000 pcs	Yes	Yes

xxx : The output voltage can be designated in the range from 2.5V(025) to 12.0V(120) in 0.1V steps.
 (For other voltages, please refer to MARK INFORMATIONS.)
 The output voltage adjustable type is fixed at 001 (Reference voltage=2.5V)

* : (B) Fixed Output Type
 (C) Adjustable Output Type

PIN CONFIGURATION

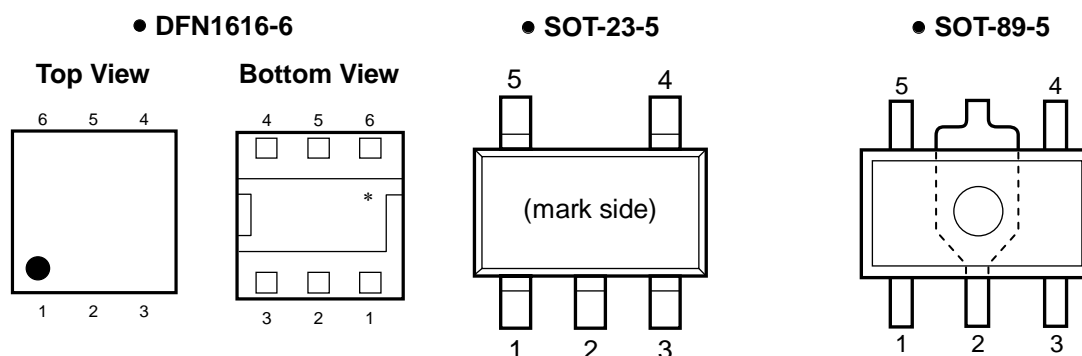

PIN DESCRIPTION

• DFN1616-6

Pin No	Symbol	Description	
1	V_{DD}	Input Pin	
2	NC	No Connection	
3	V_{OUT}	Voltage Regulator Output Pin	
4	CE	Chip Enable Pin	
5	NC	R1154LxxxB (B version)	No Connection
	ADJ	R1154L001C (C version)	Reference Voltage of Adjustable Output Pin
6	GND	Ground Pin	

*) Tab is GND level. (They are connected to the reverse side of this IC.)

The tab is better to be connected to the GND, but leaving it open is also acceptable.

• SOT-23-5

Pin No	Symbol	Description	
1	V_{OUT}	Voltage Regulator Output Pin	
2	GND	Ground Pin	
3	V_{DD}	Input Pin	
4	NC	R1154NxxxB (B version)	No Connection
	ADJ	R1154N001C (C version)	Reference Voltage of Adjustable Output Pin
5	CE	Chip Enable Pin	

• SOT-89-5

Pin No	Symbol	Description	
1	V_{OUT}	Voltage Regulator Output Pin	
2	GND	Ground Pin	
3	CE	Chip Enable Pin	
4	NC	R1154HxxxB (B version)	No Connection
	ADJ	R1154H001C (C version)	Reference Voltage of Adjustable Output Pin
5	V_{DD}	Input Pin	

ABSOLUTE MAXIMUM RATINGS

Symbol	Item	Rating	Unit
V_{IN}	Input Voltage	26.0	V
V_{CE}	Input Voltage (CE Input Pin)	-0.3 to $V_{IN}+0.3$	V
V_{OUT}	Output Voltage	-0.3 to $V_{IN}+0.3$	V
V_{ADJ}	Output Voltage (ADJ Pin)	-0.3 to $V_{IN}+0.3$	V
I_{OUT}	Output Current	250	mA
P_D	Power Dissipation (DFN1616-6)*	640	mW
	Power Dissipation (SOT-23-5)*	420	
	Power Dissipation (SOT-89-5)*	900	
T_{opt}	Operating Temperature	-40 to +105	°C
T_{stg}	Storage Temperature	-55 to +125	°C

*) For Power Dissipation please refer to PACKAGE INFORMATION.

ABSOLUTE MAXIMUM RATINGS

Electronic and mechanical stress momentarily exceeded absolute maximum ratings may cause the permanent damages and may degrade the life time and safety for both device and system using the device in the field.

The functional operation at or over these absolute maximum ratings is not assured.

POWER DISSIPATION (DFN1616-6)

This specification is at mounted on board. Power Dissipation (P_D) depends on conditions of mounting on board. This specification is based on the measurement at the condition below:

Measurement Conditions

	Standard Land Pattern
Environment	Mounting on Board (Wind velocity=0m/s)
Board Material	Glass cloth epoxy plastic (Double sided)
Board Dimensions	40mm × 40mm × 1.6mm
Copper Ratio	Top side : Approx. 50% , Back side : Approx. 50%
Through-holes	φ0.5mm × 32pcs

Measurement Results

($T_{opt}=25^{\circ}\text{C}$, $T_{jmax}=125^{\circ}\text{C}$)

	Standard Land Pattern
Power Dissipation	640mW
Thermal Resistance	$\theta_{ja}=(125-25^{\circ}\text{C})/0.64\text{W}=156^{\circ}\text{C/W}$
Thermal Resistance	$\theta_{jc}=23^{\circ}\text{C/W}$

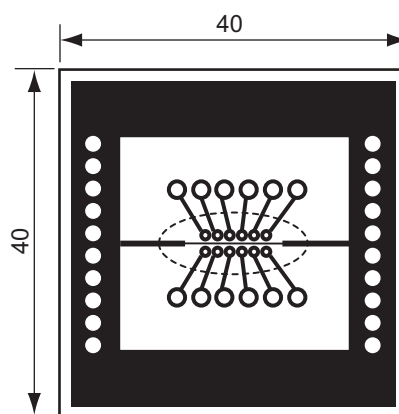
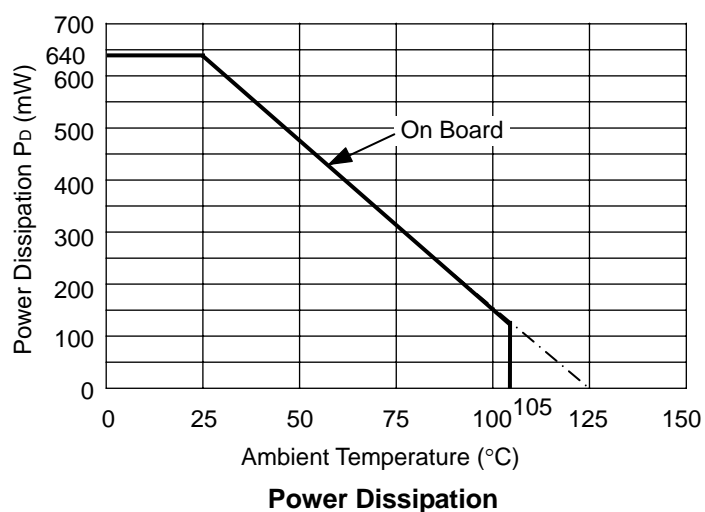

Measurement Board Pattern

○ IC Mount Area (Unit: mm)

RECOMMENDED LAND PATTERN

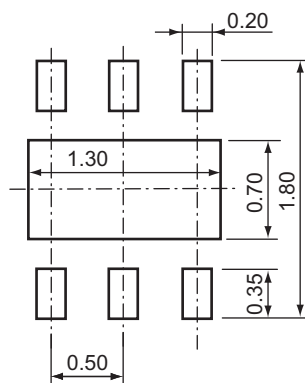

(Unit: mm)

POWER DISSIPATION (SOT-23-5)

This specification is at mounted on board. Power Dissipation (P_D) depends on conditions of mounting on board. This specification is based on the measurement at the condition below:

(Power Dissipation (SOT-23-5) is substitution of SOT-23-6.)

Measurement Conditions

	Standard Land Pattern
Environment	Mounting on Board (Wind velocity=0m/s)
Board Material	Glass cloth epoxy plastic (Double sided)
Board Dimensions	40mm × 40mm × 1.6mm
Copper Ratio	Top side : Approx. 50% , Back side : Approx. 50%
Through-holes	φ0.5mm × 44pcs

Measurement Results

($T_{opt}=25^{\circ}\text{C}$, $T_{jmax}=125^{\circ}\text{C}$)

	Standard Land Pattern	Free Air
Power Dissipation	420mW	250mW
Thermal Resistance	$\theta_{ja}=(125-25^{\circ}\text{C})/0.42\text{W}=238^{\circ}\text{C/W}$	400 $^{\circ}\text{C/W}$

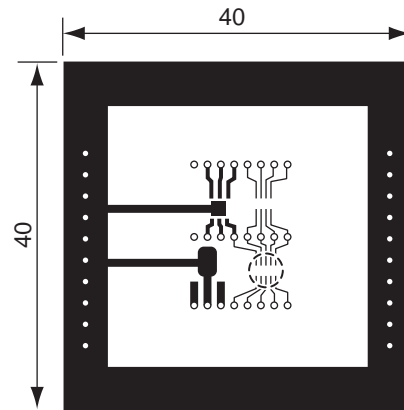
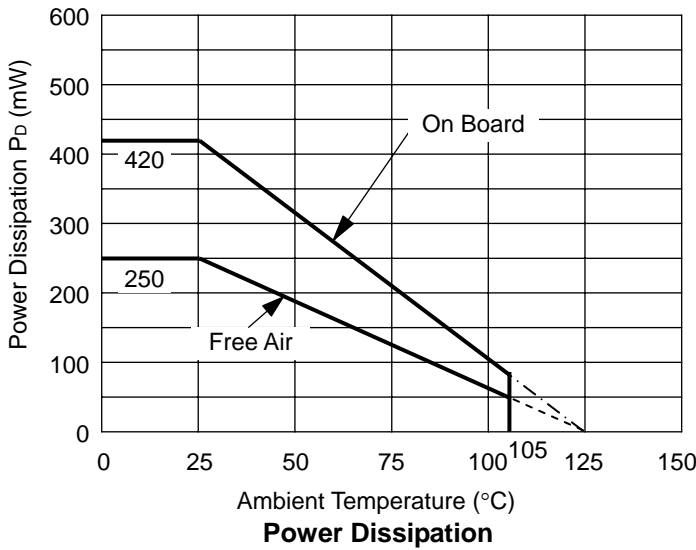

Measurement Board Pattern

○ IC Mount Area (Unit: mm)

RECOMMENDED LAND PATTERN

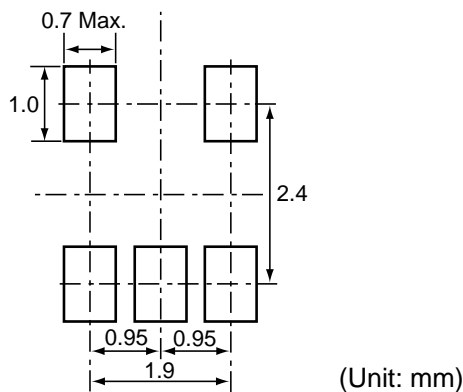

POWER DISSIPATION (SOT-89-5)

This specification is at mounted on board. Power Dissipation (P_D) depends on conditions of mounting on board. This specification is based on the measurement at the condition below:

Measurement Conditions

	High Wattage Land Pattern	Standard Land Pattern
Environment	Mounting on Board (Wind velocity=0m/s)	Mounting on Board (Wind velocity=0m/s)
Board Material	Glass cloth epoxy plastic (Double sided)	Glass cloth epoxy plastic (Double sided)
Board Dimensions	30mm × 30mm × 1.6mm	50mm × 50mm × 1.6mm
Copper Ratio	Top side : Approx. 20% , Back side : Approx. 100%	Top side : Approx. 10% , Back side : Approx. 100%
Through-holes	φ0.85mm × 10pcs	–

Measurement Results

($T_{opt}=25^{\circ}\text{C}$, $T_{jmax}=125^{\circ}\text{C}$)

	High Wattage Land Pattern	Standard Land Pattern	Free Air
Power Dissipation	1300mW	900mW	500mW
Thermal Resistance	77°C/W	111°C/W	200°C/W

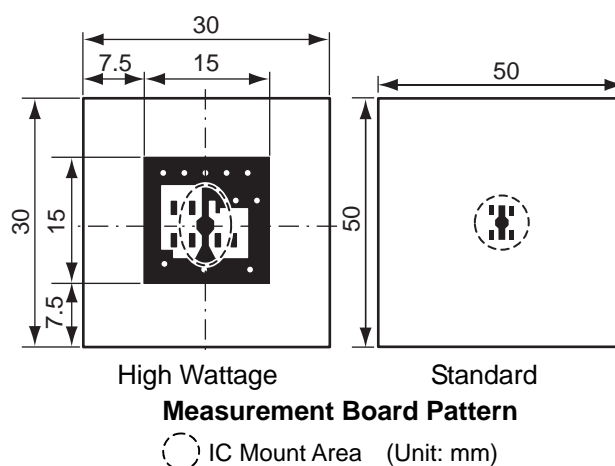
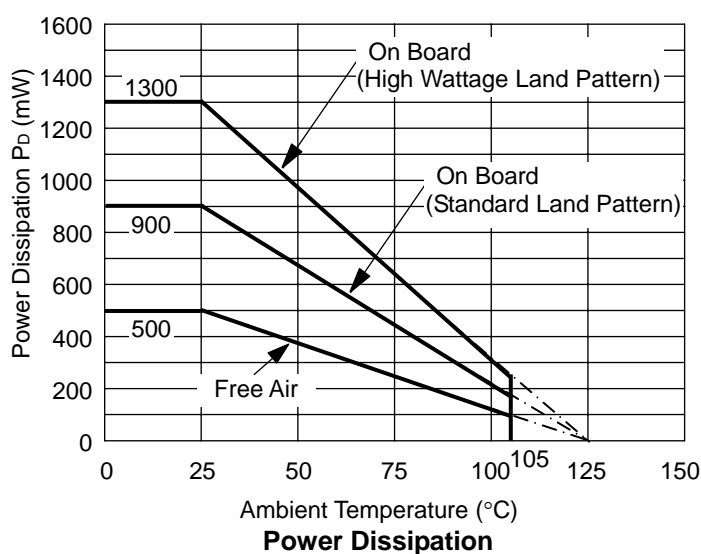

RECOMMENDED LAND PATTERN

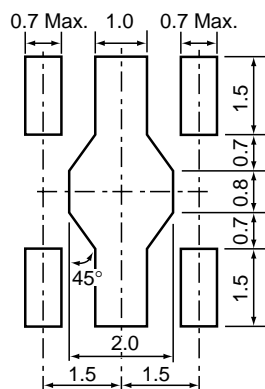

ELECTRICAL CHARACTERISTICS

• R1154xxxxB

T_{opt}=25°C

Symbol	Item	Conditions	Min.	Typ.	Max.	Unit
V _{IN}	Input Voltage				24	V
V _{OUT}	Output Voltage	V _{IN} =V _{SET} +2.0V, I _{OUT} =20mA	×0.98		×1.02	V
I _{OUT}	Output Current	V _{IN} -V _{SET} =2.0V	Refer to the following table			
I _{SS}	Supply Current	V _{IN} =V _{CE} , V _{IN} -V _{SET} =2.0V		5	10	μA
I _{standby}	Standby Current	V _{IN} =24V, V _{CE} =0V		0.1	1.0	μA
ΔV _{OUT} / ΔI _{OUT}	Load regulation	V _{IN} -V _{SET} =2.0V, 1mA ≤ I _{OUT} ≤ 40mA	Refer to the following table			
ΔV _{OUT} / ΔV _{IN}	Line regulation	I _{OUT} =20mA V _{SET} +1V ≤ V _{IN} ≤ 24V		0.05	0.20	%/V
V _{DIF}	Dropout Voltage	I _{OUT} =20mA	Refer to the following table			
ΔV _{OUT} / ΔT _{opt}	Output Voltage Temperature Coefficient	V _{IN} -V _{SET} =2.0V, I _{OUT} =20mA -40°C ≤ T _{opt} ≤ 105°C		±100		ppm/°C
I _{SC}	Short Current Limit	V _{OUT} =0V		45		mA
V _{CEH}	CE "H" Input Voltage		2.1		V _{IN}	V
V _{CEL}	CE "L" Input Voltage		0		0.3	V
T _{SD}	Thermal Shutdown Temperature	Junction Temperature		150		°C
T _{SR}	Thermal Shutdown Released Temperature	Junction Temperature		125		°C

• Output Current (T_{opt}=25°C)

Set Output Voltage V _{SET} (V)	Output Current (mA)
	Min.
2.5 ≤ V _{SET} ≤ 2.9	140
3.0 ≤ V _{SET} ≤ 12.0	150

• Load Regulation (T_{opt}=25°C)

Set Output Voltage V _{OUT} (V)	Load Regulation (mV)	
	Typ.	Max.
2.5 ≤ V _{SET} ≤ 3.0	20	50
3.1 ≤ V _{SET} ≤ 5.0	30	75
5.1 ≤ V _{SET} ≤ 12.0	40	115

• Dropout Voltage (T_{opt}=25°C)

Set Output Voltage V _{OUT} (V)	Dropout Voltage (V)	
	Typ.	Max.
2.5 ≤ V _{SET} ≤ 7.0	0.20	0.40
7.1 ≤ V _{SET} ≤ 10.0	0.25	0.50
10.1 ≤ V _{SET} ≤ 12.0	0.30	0.55

• R1154x001C

T_{opt}=25°C

Symbol	Item	Conditions	Min.	Typ.	Max.	Unit
V _{IN}	Input Voltage				24	V
V _{OUT}	Output Voltage	V _{IN} =V _{SET} +2.0V, I _{OUT} =20mA	2.45	2.50	2.55	V
I _{OUT}	Output Current	V _{IN} =V _{SET} +2.0V	140			mA
I _{SS}	Supply Current	V _{IN} =V _{SET} +2.0V, V _{CE} =V _{IN}		5	10	μA
I _{standby}	Standby Current	V _{IN} =24V, V _{CE} =0V		0.1	1.0	μA
ΔV _{OUT} /ΔI _{OUT}	Load regulation	V _{IN} =V _{SET} +2.0V, 1mA ≤ I _{OUT} ≤ 40mA		20	50	mV
ΔV _{OUT} /ΔV _{IN}	Line regulation	V _{SET} +1V ≤ V _{IN} ≤ 24V, I _{OUT} =20mA		0.05	0.20	%/V
V _{DIF}	Dropout Voltage	I _{OUT} =20mA		0.20	0.40	V
ΔV _{OUT} /ΔT _{opt}	Output Voltage Temperature Coefficient	V _{IN} =V _{SET} +2.0V, I _{OUT} =20mA, -40°C ≤ T _{opt} ≤ 105°C		±100		ppm/°C
I _{SC}	Short Current Limit	V _{OUT} =0V		45		mA
V _{CEH}	CE "H" Input Voltage		2.1		V _{IN}	V
V _{CEL}	CE "L" Input Voltage		0		0.3	V
T _{SD}	Thermal Shutdown Temperature	Junction Temperature		150		°C
T _{SR}	Thermal Shutdown Released Temperature	Junction Temperature		125		°C

The above specifications measured at the condition of V_{OUT}=V_{ADJ}.

RECOMMENDED OPERATING CONDITIONS (ELECTRICAL CHARACTERISTICS)

All of electronic equipment should be designed that the mounted semiconductor devices operate within the recommended operating conditions. The semiconductor devices cannot operate normally over the recommended operating conditions, even if when they are used over such conditions by momentary electronic noise or surge. And the semiconductor devices may receive serious damage when they continue to operate over the recommended operating conditions.

TYPICAL APPLICATIONS

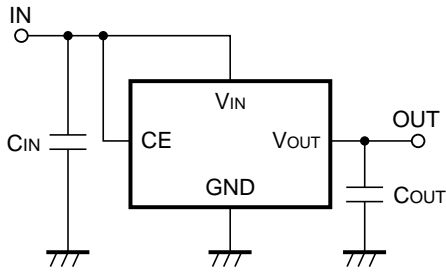

Fixed Output Voltage Type

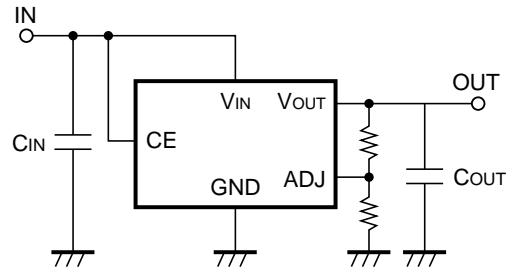

Adjustable Type

TEST CIRCUITS

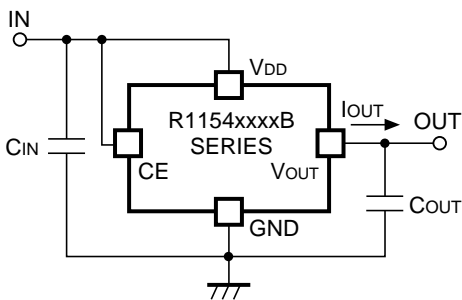

R1154xxxxB Standard Test Circuit

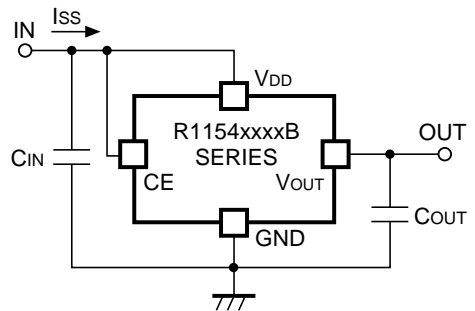

R1154xxxxB Supply Current Test Circuit

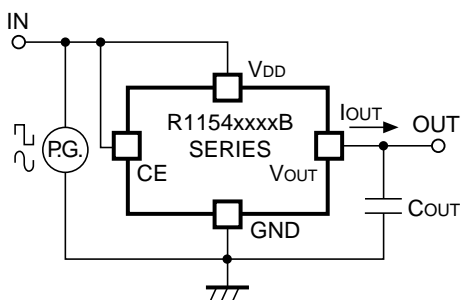

R1154xxxxB Input Transient Response Test Circuit

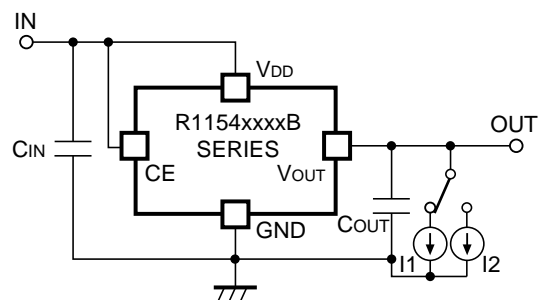

R1154xxxxB Load Regulation Test Circuit

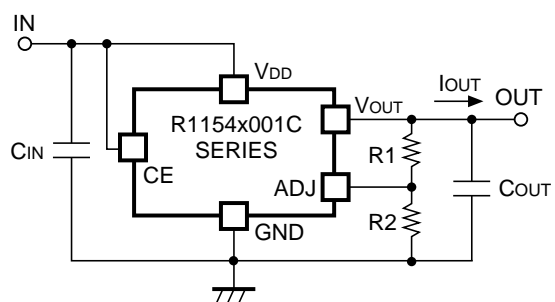

R1154x001C Standard Test Circuit

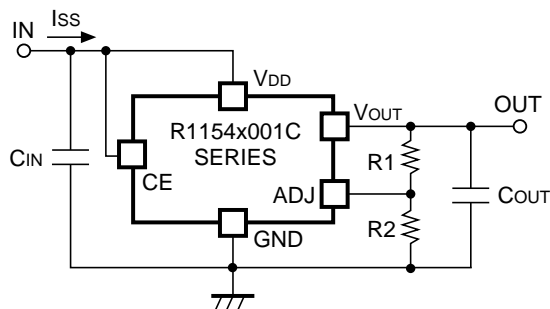

R1154x001C Supply Current Test Circuit

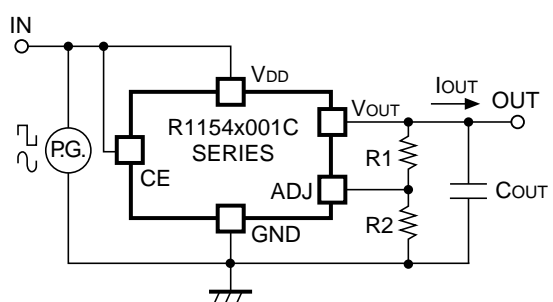

R1154x001C Input Transient Response Test Circuit

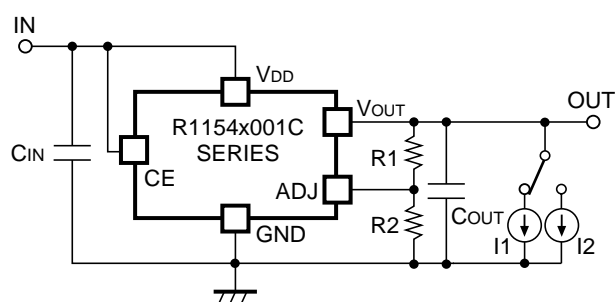

R1154x001C Load Transient Response Test Circuit

TYPICAL CHARACTERISTICS

1) Output Voltage vs. Output Current

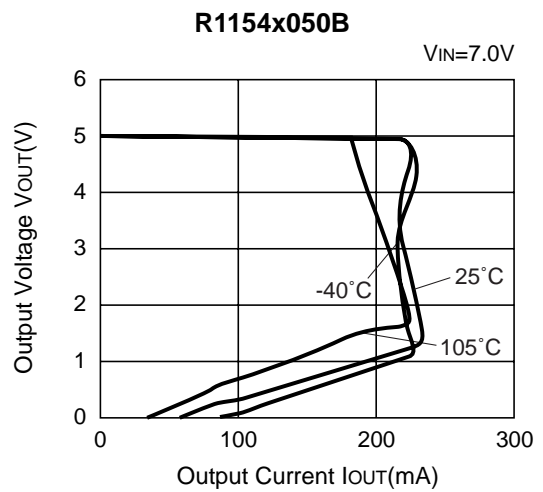
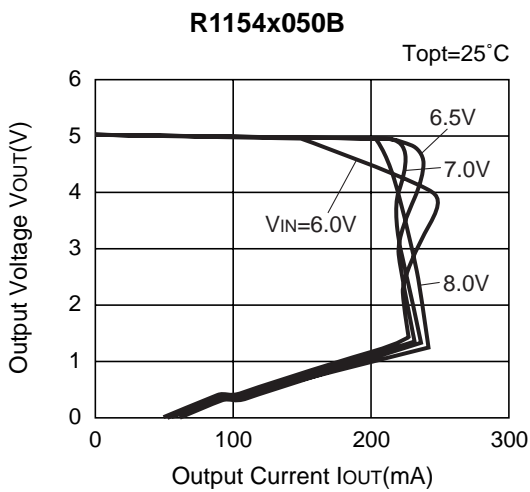
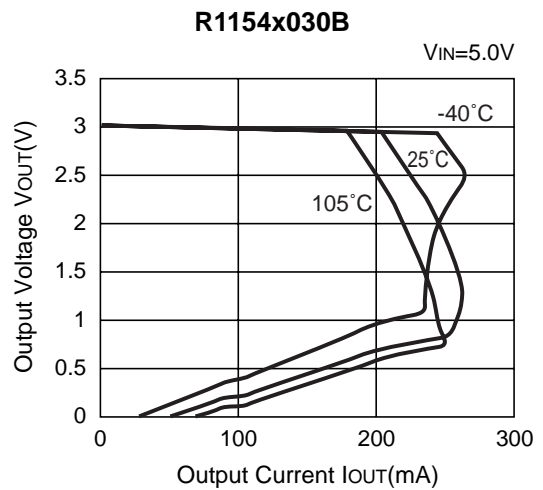
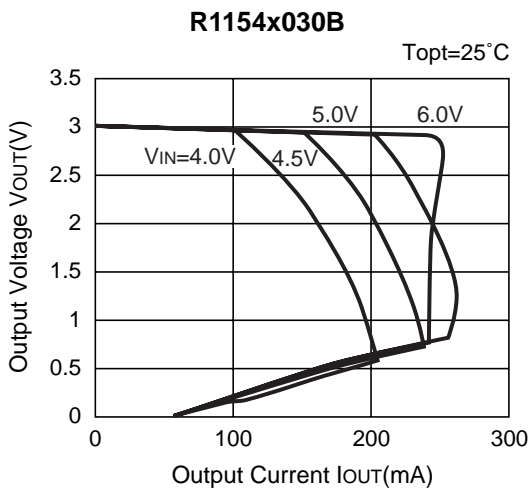
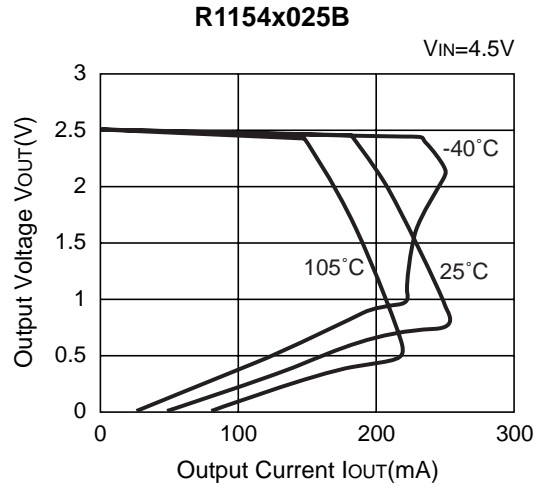
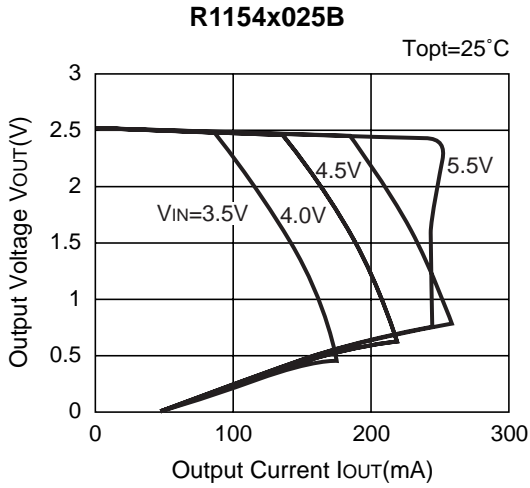

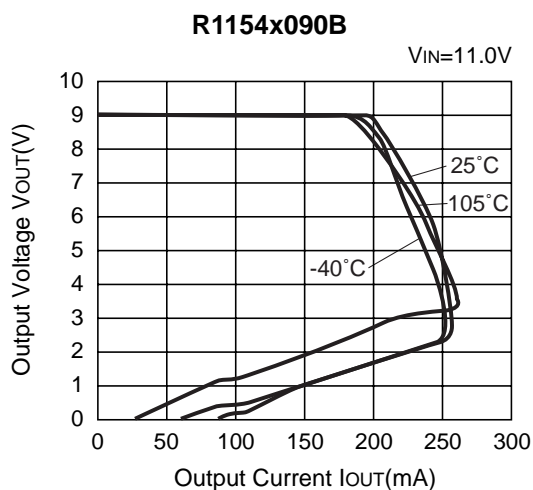
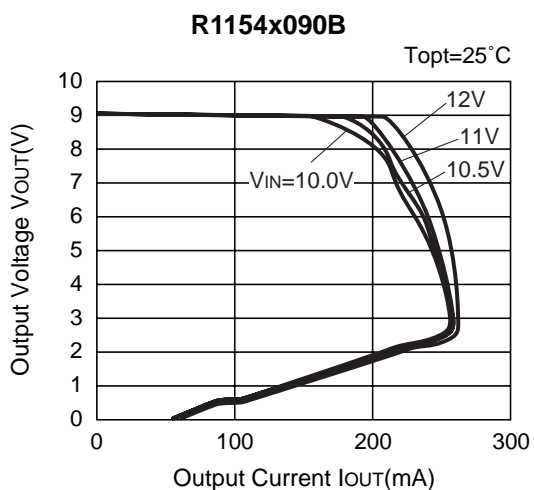

2) Input Voltage vs. Output Voltage ($T_{opt}=25^{\circ}\text{C}$)

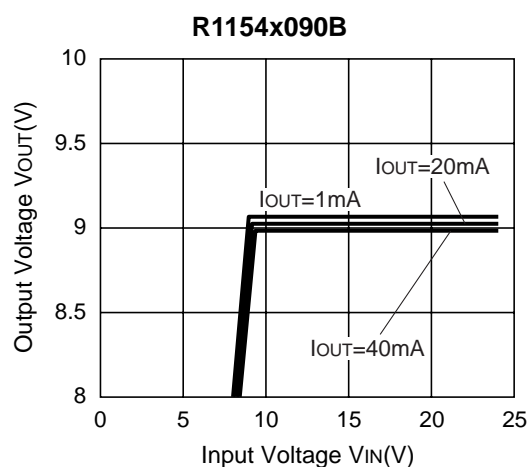
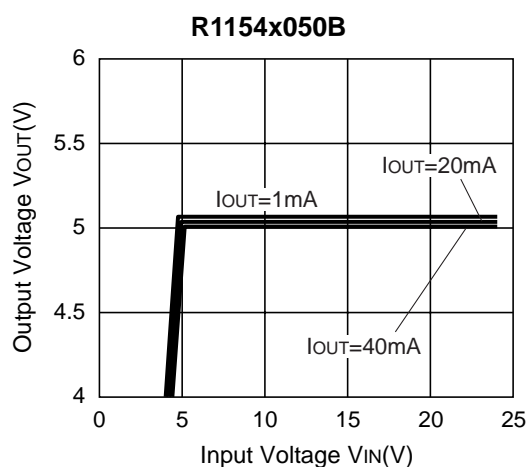
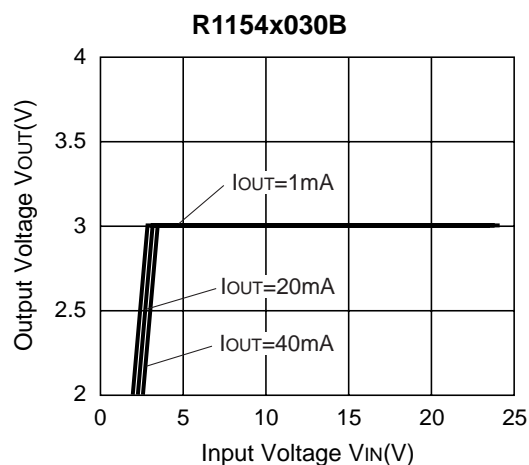
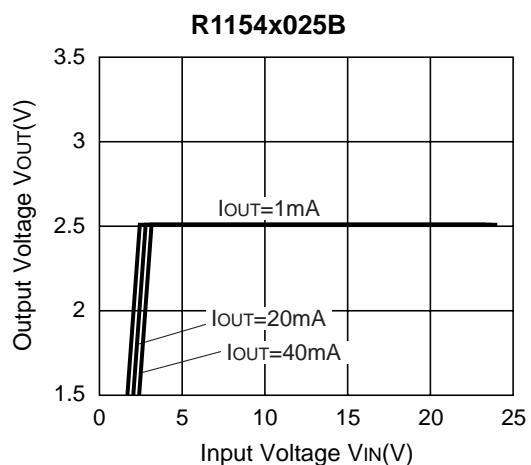

3) Dropout Voltage vs. Output Current

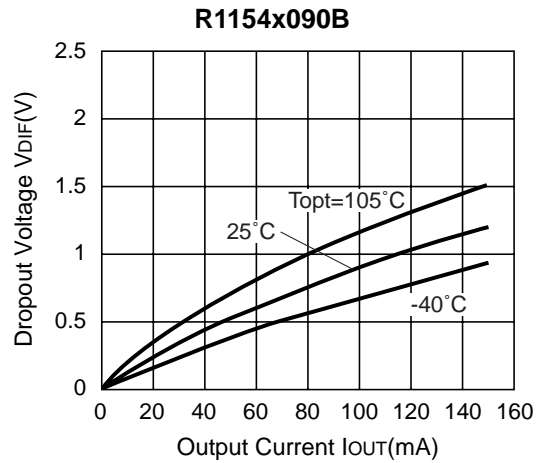
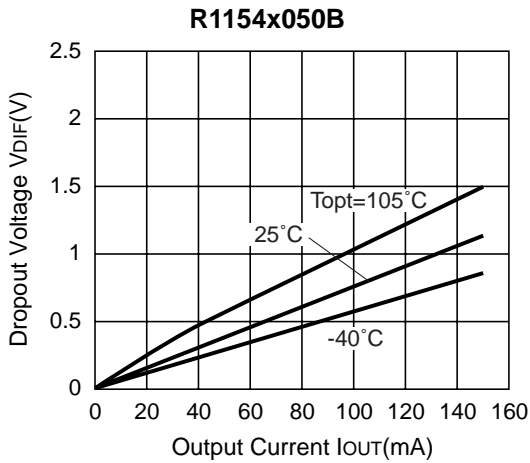
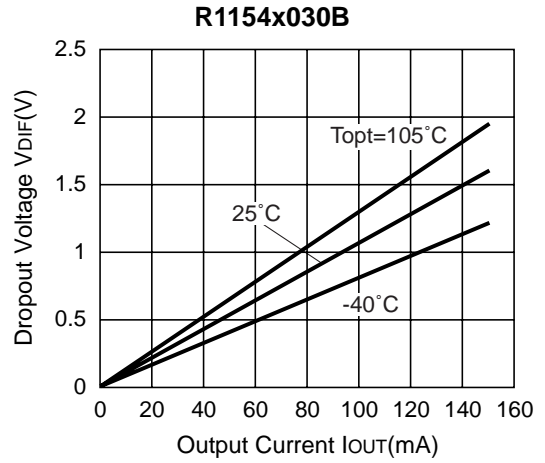
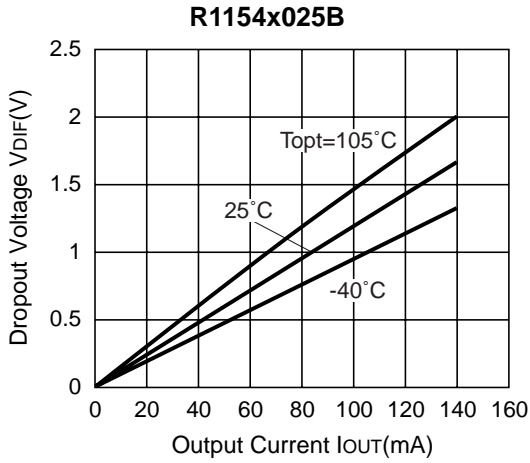

4) Output Voltage vs. Temperature

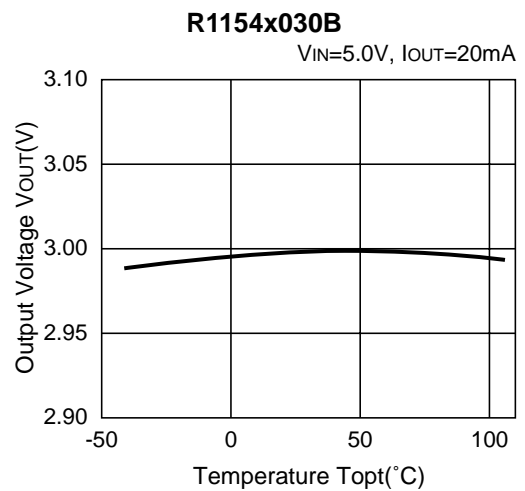
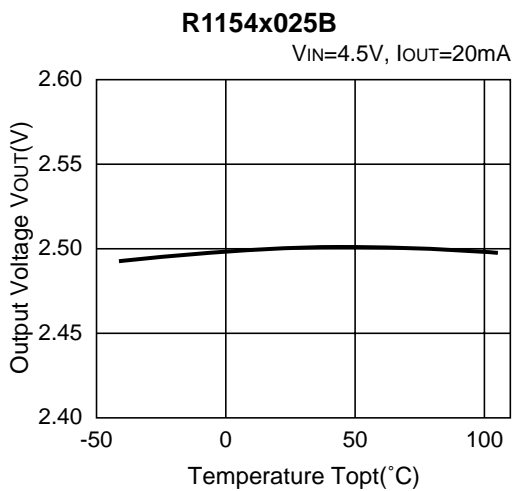

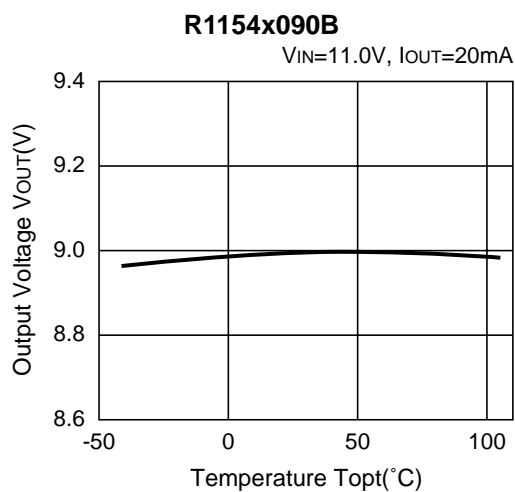
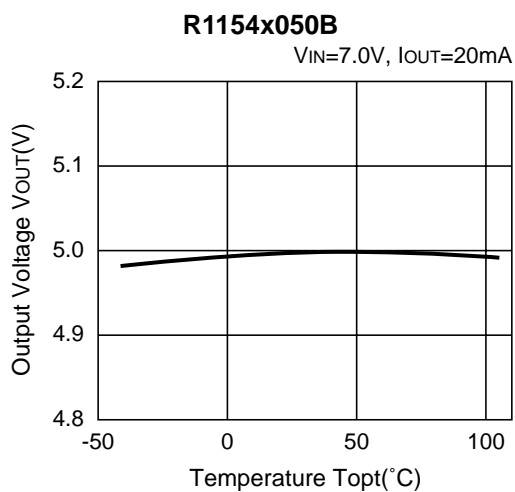

5) Supply Current vs. Input Voltage (T_{opt}=25°C)

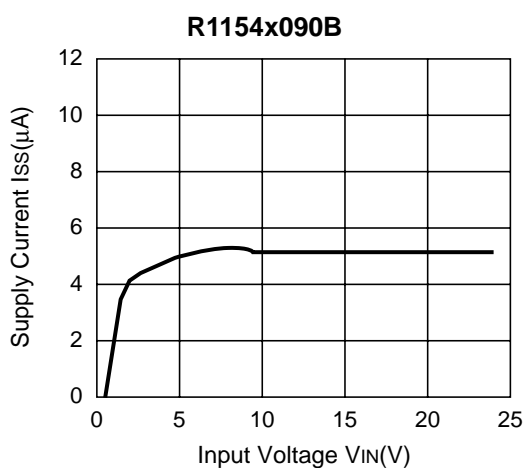
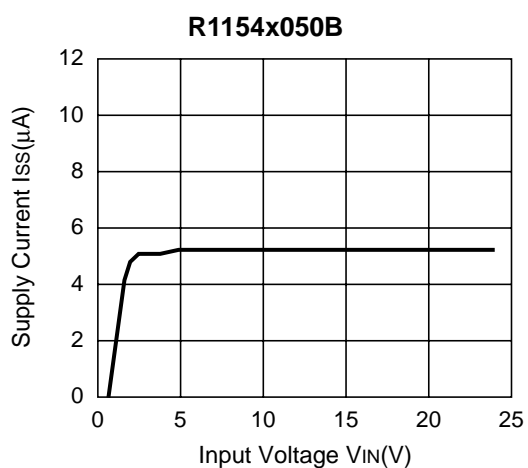
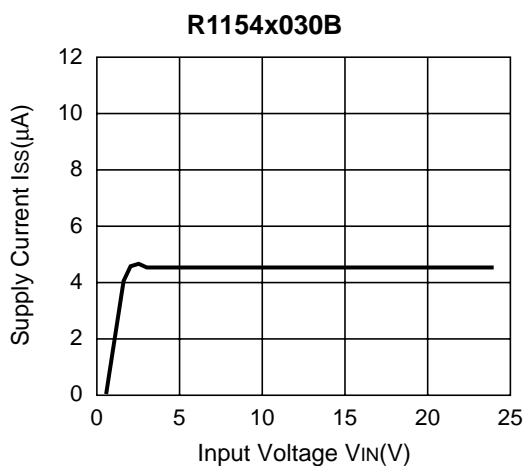
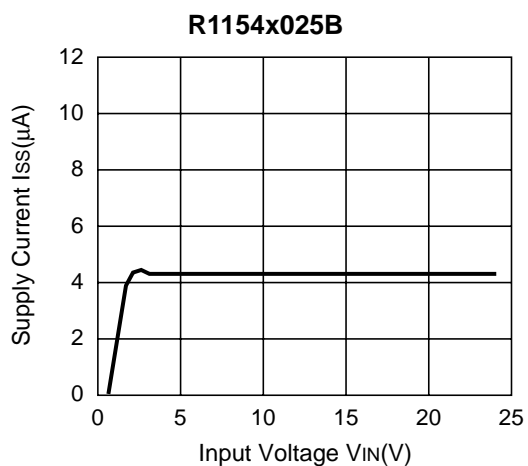

6) Supply Current vs. Temperature

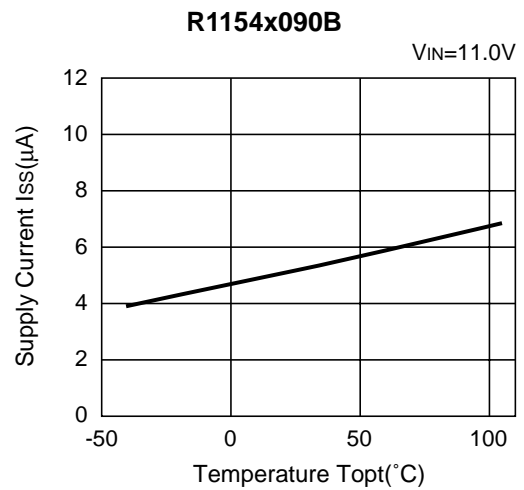
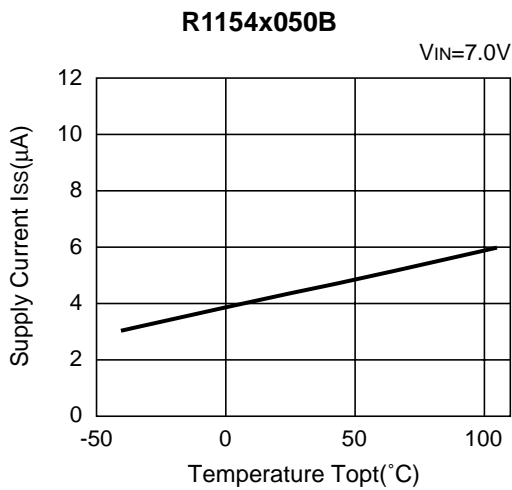
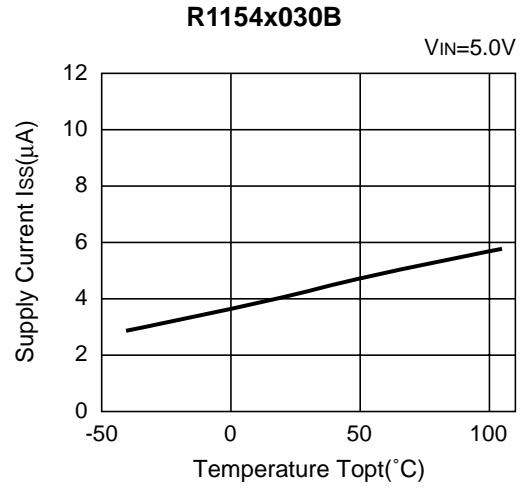
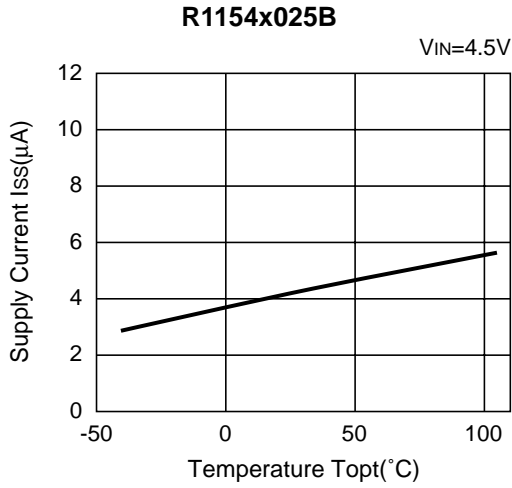

7) Input Transient Response ($I_{OUT}=20mA$, $C_{OUT}=0.1\mu F$, $T_{opt}=25^\circ C$)

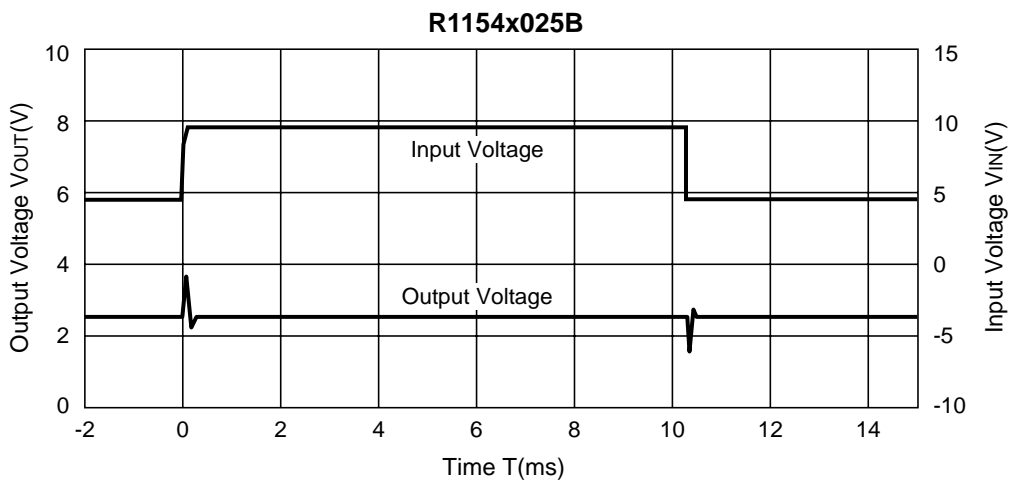

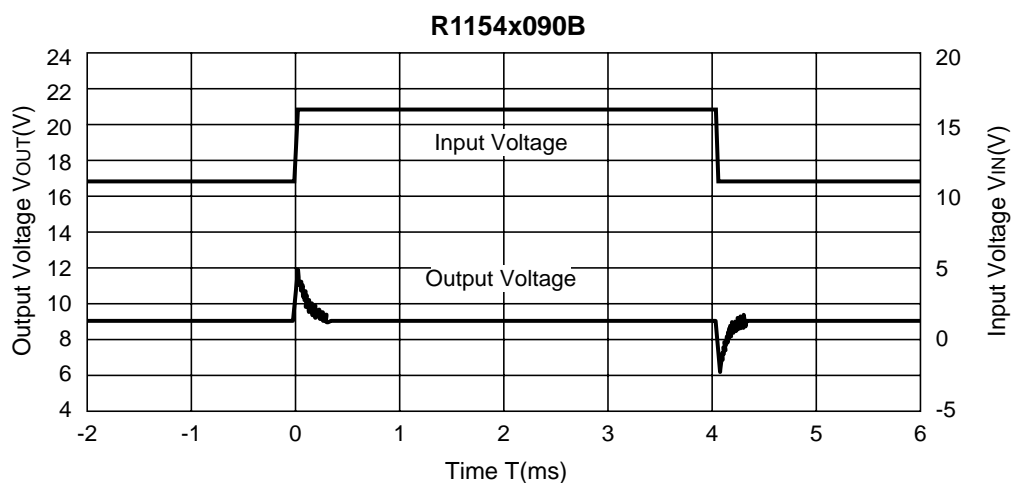
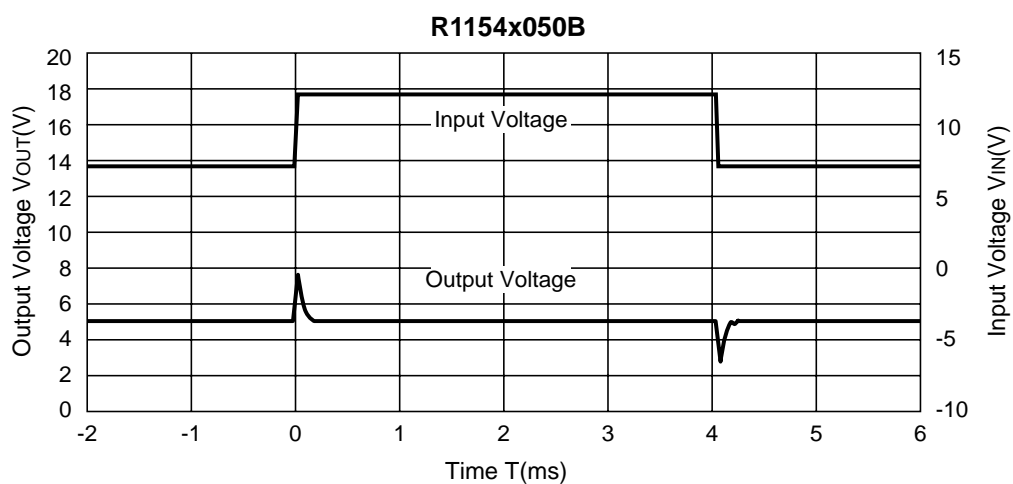
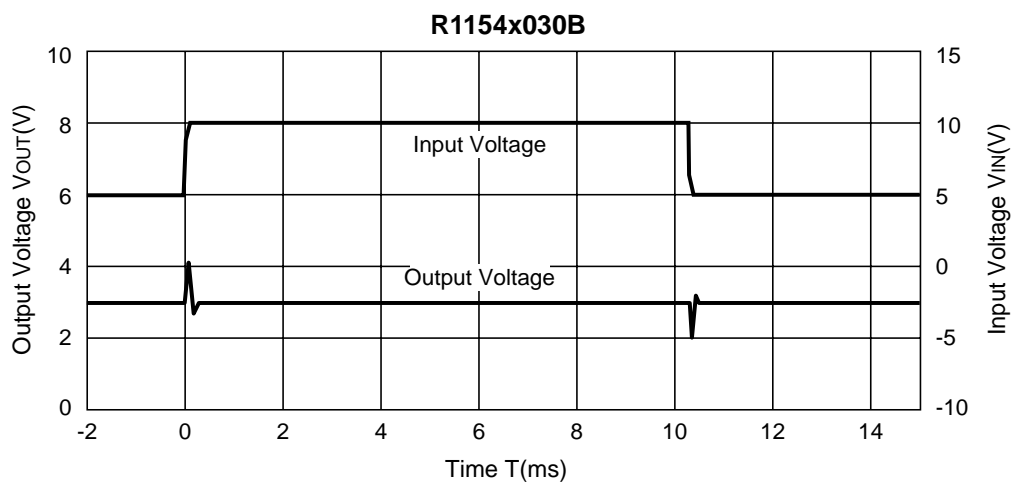

8) Load Transient Response ($C_{OUT}=0.1\mu F$, $T_{opt}=25^{\circ}C$)

R1154x025B

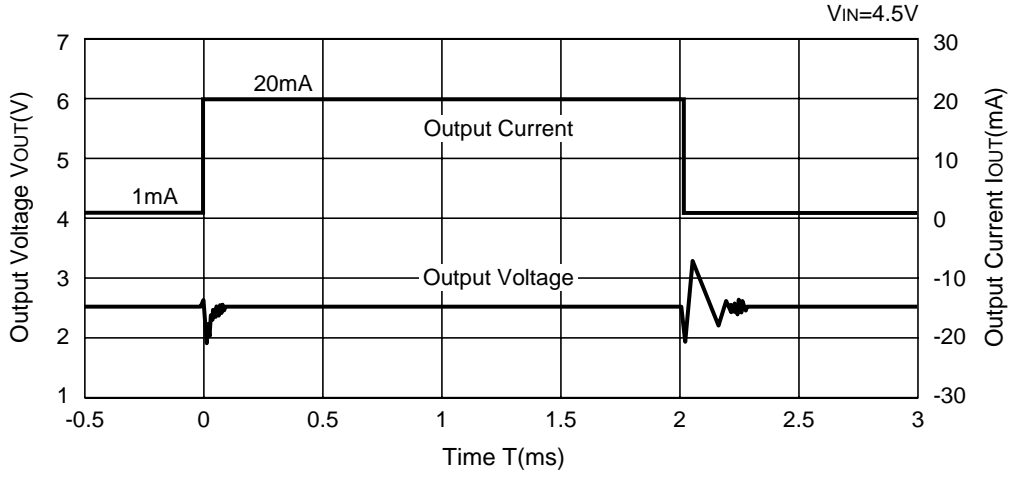

R1154x030B

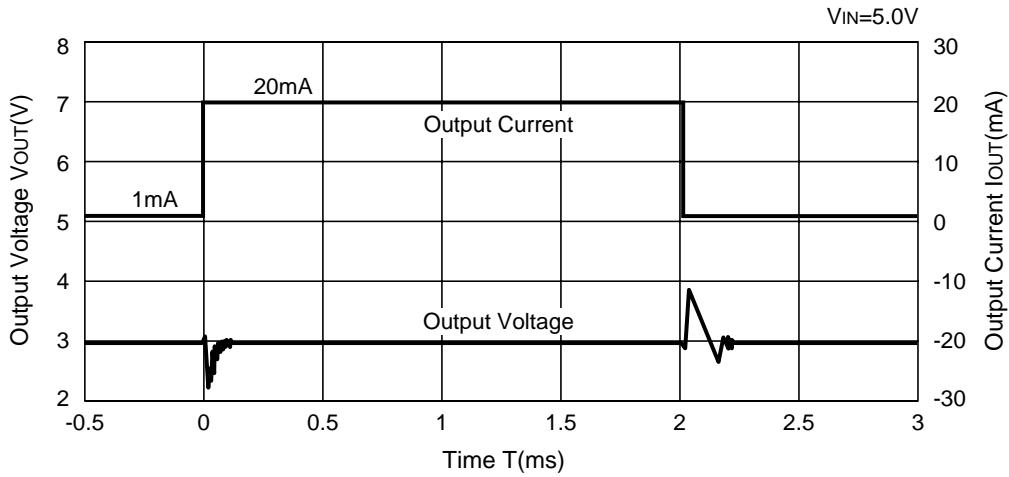

R1154x050B

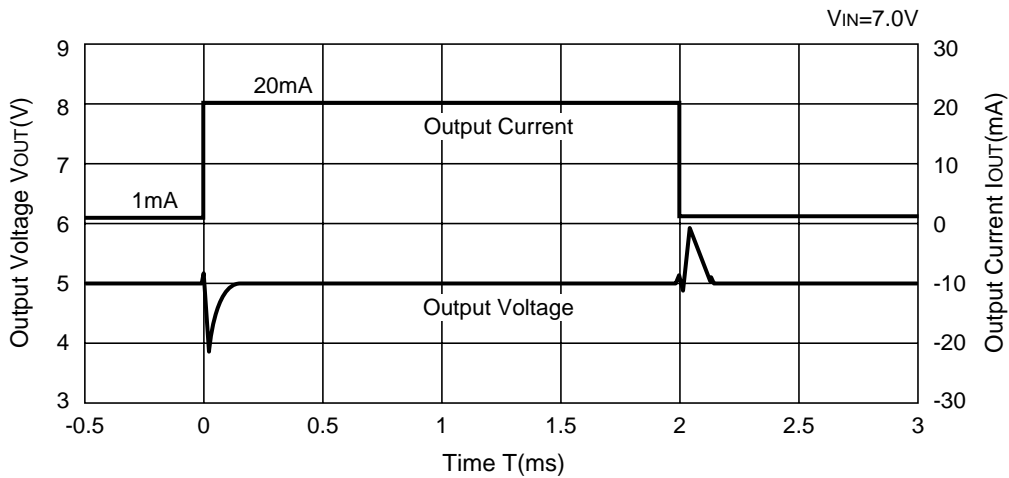

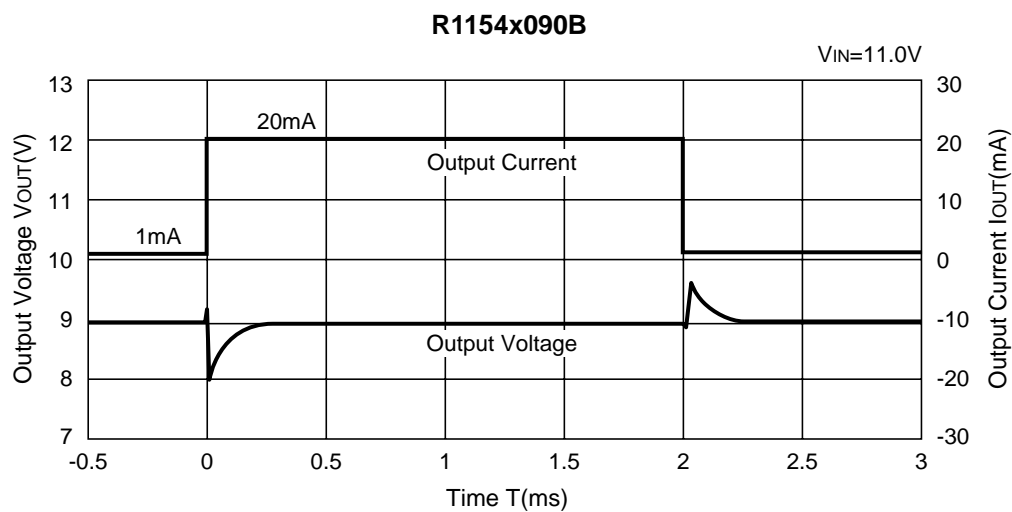

9) Thermal Shutdown Characteristics

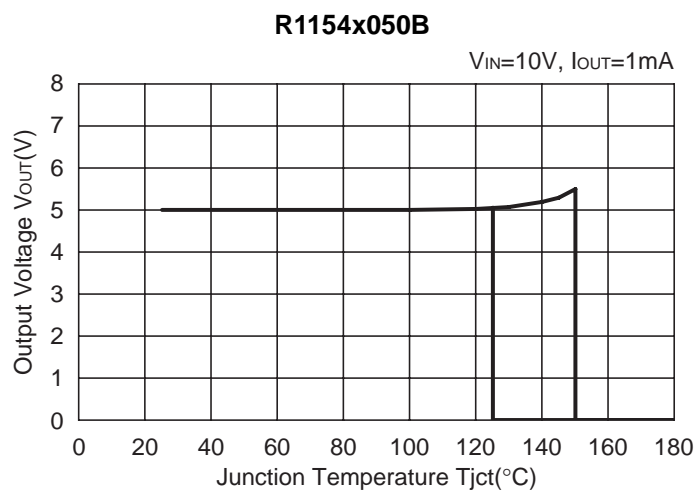

TECHNICAL NOTES

Phase Compensation

Phase Compensation of the R1154x Series has been made internally for stable operation even though the load current would vary. Therefore, without the capacitors, C_{IN} and C_{OUT} , the output voltage is regulated, however, for more stable operation, use capacitors as C_{IN} and C_{OUT} . Especially, if the input line is long and impedance is high, C_{IN} is necessary, moreover, if you use C_{OUT} , transient response will be improved. Recommended value is in the range from $0.1\mu\text{F}$ to $2.2\mu\text{F}$. Wiring should be made as short as possible.

Connect the capacitor, C_{IN} between V_{DD} pin and GND pin and C_{OUT} between V_{OUT} and GND as close as possible.

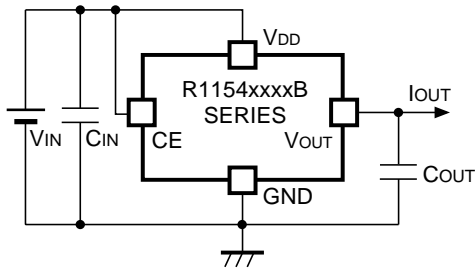

R1154xxxxB Typical Application

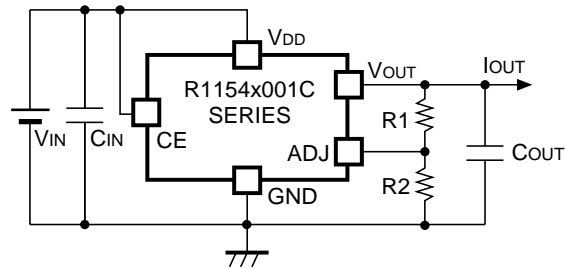

R1154xxxxC Typical Application

Thermal Shutdown

Thermal shutdown function is included in the R1154x Series, if the junction temperature is equal or more than $+150^{\circ}\text{C}$ (Typ.), the operation of regulator would stop. After that, when the junction temperature is equal or less than $+125^{\circ}\text{C}$ (Typ.), the operation of regulator would restart. Unless the cause of rising temperature would remove, the regulator repeats on and off, and output waveform would be like consecutive pulses.

Chip Enable Circuit

Do not make voltage level of chip enable pin keep floating level, or in between V_{IH} and V_{IL} . Unless otherwise, Output voltage would be unstable or indefinite, or unexpected current would flow internally.

* Technical Notes on Output Voltage Setting of C type

Figure 1. Adjustable Regulator (C type)

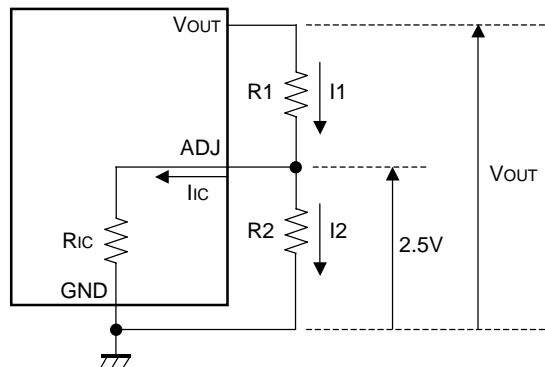

The Output Voltage of Regulator in R1154xxxxC may be adjustable for any output voltage between its 2.5V reference and its V_{DD} setting level. An external pair of resistors is required, as shown in Figure 1. The complete equation for the output voltage is described step by step as follows;

$$I_1 = I_{IC} + I_2 \dots\dots\dots (1)$$

$$I_2 = 2.5/R_2 \dots\dots\dots (2)$$

Thus,

$$I_1 = I_{IC} + 2.5/R_2 \dots\dots\dots (3)$$

Therefore,

$$V_{OUT} = 2.5 + R_1 \times I_1 \dots\dots\dots (4)$$

Put Equation (3) into Equation (4), then

$$\begin{aligned} V_{OUT} &= 2.5 + R_1(I_{IC} + 2.5/R_2) \\ &= 2.5(1 + R_1/R_2) + R_1 \times I_{IC} \dots\dots\dots (5) \end{aligned}$$

In 2nd term, or $R_1 \times I_{IC}$ will produce an error in V_{OUT} .

In Equation (5),

$$I_{IC} = 2.5/R_{IC} \dots\dots\dots (6)$$

$$\begin{aligned} R_1 \times I_{IC} &= R_1 \times 2.5/R_{IC} \\ &= 2.5 \times R_1/R_{IC} \dots\dots\dots (7) \end{aligned}$$

For better accuracy, choosing $R_1 \ll R_{IC}$ reduces this error.



1. The products and the product specifications described in this document are subject to change or discontinuation of production without notice for reasons such as improvement. Therefore, before deciding to use the products, please refer to Ricoh sales representatives for the latest information thereon.
2. The materials in this document may not be copied or otherwise reproduced in whole or in part without prior written consent of Ricoh.
3. Please be sure to take any necessary formalities under relevant laws or regulations before exporting or otherwise taking out of your country the products or the technical information described herein.
4. The technical information described in this document shows typical characteristics of and example application circuits for the products. The release of such information is not to be construed as a warranty of or a grant of license under Ricoh's or any third party's intellectual property rights or any other rights.
5. The products listed in this document are intended and designed for use as general electronic components in standard applications (office equipment, telecommunication equipment, measuring instruments, consumer electronic products, amusement equipment etc.). Those customers intending to use a product in an application requiring extreme quality and reliability, for example, in a highly specific application where the failure or misoperation of the product could result in human injury or death (aircraft, spacevehicle, nuclear reactor control system, traffic control system, automotive and transportation equipment, combustion equipment, safety devices, life support system etc.) should first contact us.
6. We are making our continuous effort to improve the quality and reliability of our products, but semiconductor products are likely to fail with certain probability. In order to prevent any injury to persons or damages to property resulting from such failure, customers should be careful enough to incorporate safety measures in their design, such as redundancy feature, firecontainment feature and fail-safe feature. We do not assume any liability or responsibility for any loss or damage arising from misuse or inappropriate use of the products.
7. Anti-radiation design is not implemented in the products described in this document.
8. Please contact Ricoh sales representatives should you have any questions or comments concerning the products or the technical information.

RICOH COMPANY, LTD. Electronic Devices Company



■ Ricoh presented with the Japan Management Quality Award for 1999.
Ricoh continually strives to promote customer satisfaction, and shares the achievements of its management quality improvement program with people and society.



■ Ricoh awarded ISO 14001 certification.

The Ricoh Group was awarded ISO 14001 certification, which is an international standard for environmental management systems, at both its domestic and overseas production facilities. Our current aim is to obtain ISO 14001 certification for all of our business offices.

<http://www.ricoh.com/LSI/>

RICOH COMPANY, LTD.

Electronic Devices Company

● Higashi-Shinagawa Office (International Sales)

3-32-3, Higashi-Shinagawa, Shinagawa-ku, Tokyo 140-8655, Japan
Phone: +81-3-5479-2857 Fax: +81-3-5479-0502

RICOH EUROPE (NETHERLANDS) B.V.

● Semiconductor Support Centre

Prof. W.H.Keesomlaan 1, 1183 DL Amstelveen, The Netherlands
P.O.Box 114, 1180 AC Amstelveen
Phone: +31-20-5474-309 Fax: +31-20-5474-791

RICOH ELECTRONIC DEVICES KOREA Co., Ltd.

11 floor, Haesung 1 building, 942, Daechidong, Gangnamgu, Seoul, Korea
Phone: +82-2-2135-5700 Fax: +82-2-2135-5705

RICOH ELECTRONIC DEVICES SHANGHAI Co., Ltd.

Room403, No.2 Building, 690#Bi Bo Road, Pu Dong New district, Shanghai 201203,
People's Republic of China
Phone: +86-21-5027-3200 Fax: +86-21-5027-3299

RICOH COMPANY, LTD.

Electronic Devices Company

● Taipei office

Room109, 10F-1, No.51, Hengyang Rd., Taipei City, Taiwan (R.O.C.)
Phone: +886-2-2313-1621/1622 Fax: +886-2-2313-1623



Ricoh completed the organization of the Lead-free production for all of our products. After Apr. 1, 2006, we will ship out the lead free products only. Thus, all products that will be shipped from now on comply with RoHS Directive.