Microprocessor power management with Watchdog Timer

NO.EA-136-111104

OUTLINE

The R5104V Series are high voltage tolerance CMOS-based microprocessor power management ICs with high accuracy output voltage and detector threshold and with ultra low supply current. Each of these ICs consists of a voltage regulator, a voltage detector and a watchdog timer. Thus, the R5104V Series have the function of a power management for microprocessor, a monitor of the voltage of a power source and a microprocessor supervisor.

The built-in voltage regulator with an external driver transistor can supply Min.1A current to a system. Therefore these ICs are very suitable for various power supply systems for microprocessors. The output voltage is monitored by the voltage detector which is built-in these ICs.

The built-in voltage detector has an output delay function and the delay time can be set by an external capacitor (C_D).

The output voltage and the detector threshold voltage can be set individually for each IC by laser trimming.

Furthermore, when a microprocessor works incorrectly, the watchdog timer which checks over microprocessor generates reset signals intermittently to prevent a whole system from being malfunction.

The timeout periods for watchdog and reset can also be set individually by an external capacitor (C_{TW}).

There are two kinds of power down function: "A" version turns off the supervisor of clock input for the watchdog timer, while the "B" version turns off all the circuits and realizes the standby mode.

FEATURES

- Supply current..... Typ. 60 μ A ($I_{OUT}=0mA$)
- Standby Current (B version)..... Typ. 0.1 μ A
- Output Voltage 3.3V to 5.0V
- Detector Threshold Voltage 2.8V to 4.0V
- Maximum Operating Input Voltage..... Max. 36V
- High Accuracy Output Voltage of Voltage Regulator and Detector Threshold $\pm 2.0\%$
- Built-in a watchdog timer
- Timeout period for watchdog and generating a reset signal can be set by an external capacitor
- Watchdog timer can be stopped individually by CE Pin
- Power-on Reset Delay Time can be set by an external capacitor
- Package SSOP-10

APPLICATION

- Power source for microprocessors

BLOCK DIAGRAMS

R5104VxxxA

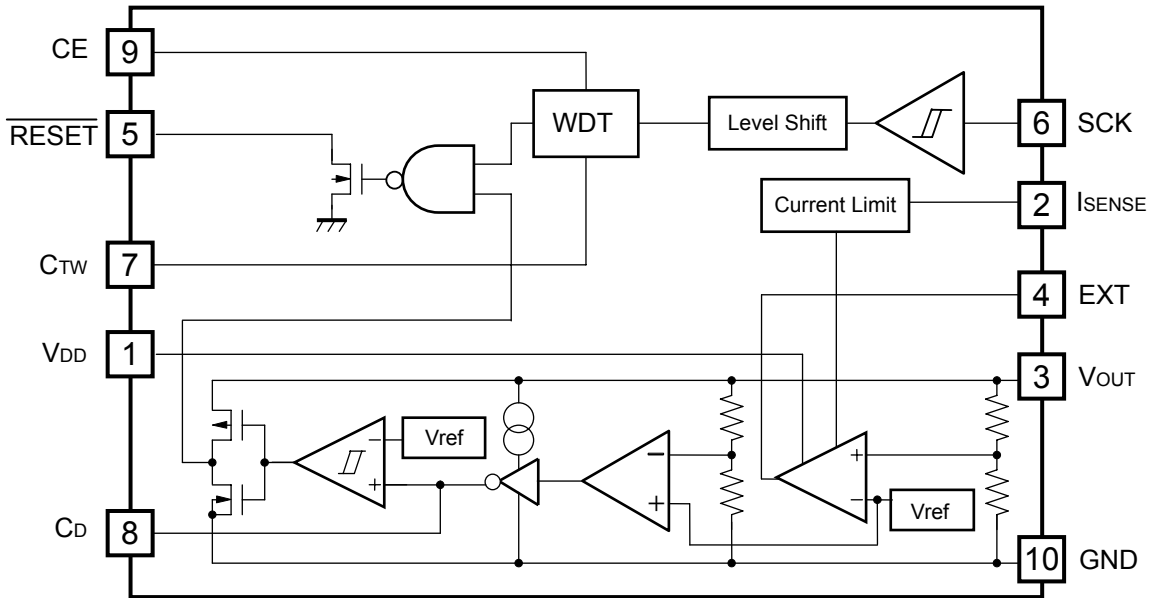

R5104VxxxB

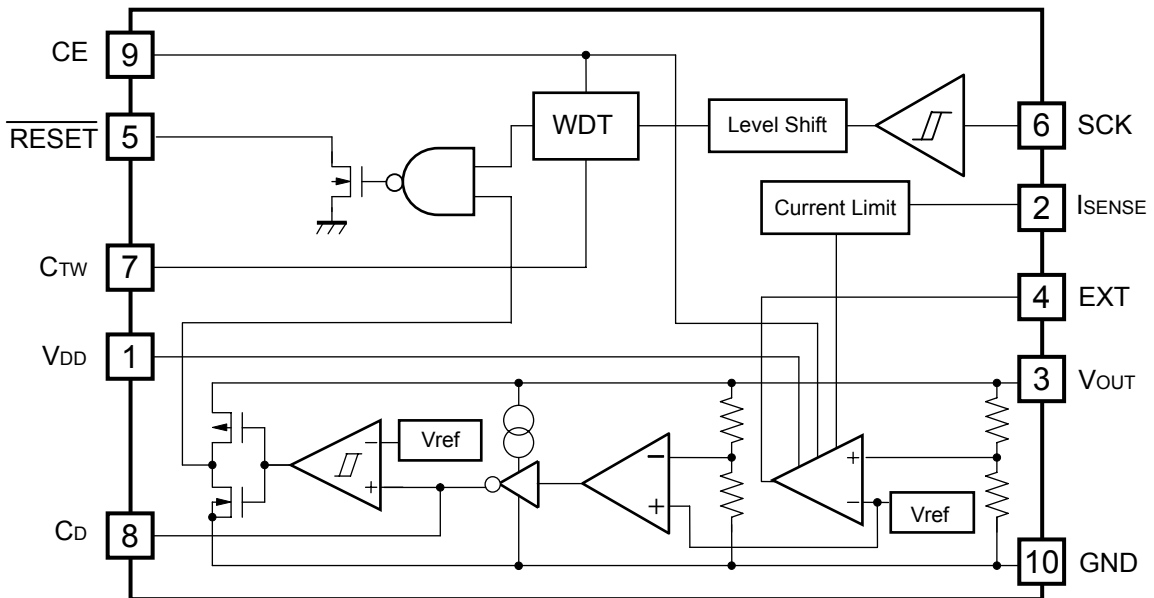

SELECTION GUIDE

The output voltage, the detector threshold, and the operation of the CE pin for the ICs can be selected at the users' request.

| Product Name | Package | Quantity per Reel | Pb Free | Halogen Free |
|--|---------|-------------------|---------|--------------|
| R5104Vxxx*-E2-KG | SSOP-10 | 2,000 pcs | Yes | Yes |
| xxx : The combination of output voltage and detector threshold for each channel can be designated by serial numbers. (For details, please refer to MARK INFORMATIONS.) | | | | |
| * : The operation of the CE pin are options as follows. (A) Watchdog timer off (B) Standby mode | | | | |

"-KG" of the product name shows that the product is for automotive (body system) use with the operating temperature of -40°C to 125°C.

Please contact our sales representative or distributor for details.

PIN CONFIGURATION

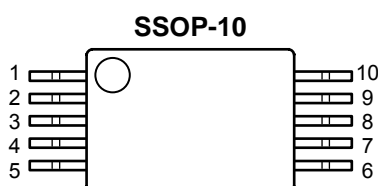

PIN DESCRIPTIONS

| Pin No | Symbol | Pin Description |
|--------|---------------------------|--|
| 1 | V _{DD} | Power supply Pin Clock |
| 2 | I _{SENSE} | Sense Pin for Current Limit of VR. Monitoring the dropout voltage generated at an external resistor between pin 1 and pin 2, if the dropout exceeds 0.3V (Typ.), the current limit works. |
| 3 | V _{OUT} | Output Pin for Voltage Regulator |
| 4 | EXT | External Transistor Drive Pin |
| 5 | $\overline{\text{RESET}}$ | Output Pin for Reset signal of Watchdog timer and Voltage Detector. (Output Type is Nch Open Drain, Output "L" at detecting Detector Threshold and Watchdog Timer Reset.) |
| 6 | SCK | Clock Input Pin from Microprocessor |
| 7 | C _{TW} | External Capacitor Pin for Setting Reset and Watchdog Timeout Periods |
| 8 | C _D | External Capacitor Pin for Setting Delay Time of Voltage Detector |
| 9 | CE | Control Switch Pin for halting Watchdog timer (A version), or Chip Enable Pin (B version) |
| 10 | GND | Ground Pin |

ABSOLUTE MAXIMUM RATINGS

| Symbol | Item | Rating | Unit | |
|---------------------|---|--|--|----|
| V _{DD} | Supply Voltage | -0.3 to 50 | V | |
| V _{PEAK} | Peak Input Voltage* ¹ | 60 | V | |
| V _{CD} | Output Voltage* ² | Voltage of C _D Pin | V _{SS} -0.3 to 7.5 | V |
| V _{CTW} | | Voltage of C _{TW} Pin | V _{SS} -0.3 to 7.5 | V |
| V _{OUT} | | Voltage of V _{OUT} Pin | V _{SS} -0.3 to 7.5 | V |
| V _{RESET} | | Voltage of $\overline{\text{RESET}}$ Pin | V _{SS} -0.3 to 7.5 | V |
| V _{CE} | Input Voltage | Voltage of CE Pin | V _{SS} -0.3 to V _{IN} +0.3 | V |
| V _{ISENSE} | | Voltage of I _{SENSE} Pin | V _{SS} -0.3 to V _{IN} +0.3 | V |
| V _{SCK} | | Voltage of SCK Pin | V _{SS} -0.3 to V _{IN} +0.3 | V |
| I _{EXT} | Output Current | Current of EXT Pin | 10 | mA |
| I _{RESET} | | Current of $\overline{\text{RESET}}$ Pin | 20 | mA |
| P _D | Power Dissipation (SSOP-10)* ³ | 300 | mW | |
| T _{opt} | Operating Temperature Range | -40 to +125 | °C | |
| T _{stg} | Storage Temperature Range | -55 to +140 | °C | |

*1) duration time=200ms

*2) Do not force any voltage more than supply voltage to C_D, C_{TW}, V_{OUT}, and $\overline{\text{RESET}}$ pins.

*3) For Power Dissipation, please refer to PACKAGE INFORMATION.

ABSOLUTE MAXIMUM RATINGS

Electronic and mechanical stress momentarily exceeded absolute maximum ratings may cause the permanent damages and may degrade the life time and safety for both device and system using the device in the field.

The functional operation at or over these absolute maximum ratings is not assured.

RECOMMENDED OPERATING CONDITIONS (ELECTRICAL CHARACTERISTICS)

All of electronic equipment should be designed that the mounted semiconductor devices operate within the recommended operating conditions. The semiconductor devices cannot operate normally over the recommended operating conditions, even if when they are used over such conditions by momentary electronic noise or surge. And the semiconductor devices may receive serious damage when they continue to operate over the recommended operating conditions.

ELECTRICAL CHARACTERISTICS

(Unless otherwise specified, $V_{IN}=CE=V_{ISENSE}=12V$, $I_{OUT}=100mA$, $C_{CTW}=0.1\mu F$, $C_D=0.01\mu F$)

• R5104VxxxA (Overall)

$T_{opt}=25^{\circ}C$

| Symbol | Item | Conditions | Min. | Typ. | Max. | Unit |
|-----------|-------------------------------|------------------------|------|------|--------------|---------|
| V_{IN} | Operating Voltage | | | | 36 | V |
| I_{SS} | Supply Current | $I_{OUT}=0mA$ | | 60 | 100 | μA |
| I_{off} | Supply Current (WDT inactive) | $V_{IN}=12V$, $CE=0V$ | | 50 | 90 | μA |
| V_{CEH} | CE Input Voltage"H" | | 2.0 | | $V_{IN}+0.3$ | V |
| V_{CEL} | CE Input Voltage"L" | | 0 | | 0.25 | V |

VR part

| Symbol | Item | Conditions | Min. | Typ. | Max. | Unit |
|---------------------------------|--|--|---------------|----------|---------------|------------------|
| V_{OUT} | Output Voltage | | $\times 0.98$ | | $\times 1.02$ | V |
| I_{OUT} | Output Current(*1) | $V_{IN}=12V$ | 1.0 | | | A |
| V_{DIF} | Dropout Voltage(*1) | $I_{OUT}=300mA$ | | 50 | | mV |
| $\Delta V_{OUT}/\Delta I_{OUT}$ | Load Regulation(*1) | $V_{IN}=12V$, $1mA \leq I_{OUT} \leq 1A$ | | 15 | 60 | mV |
| $\Delta V_{OUT}/\Delta V_{IN}$ | Line Regulation(*1) | $I_{OUT}=100mA$ $V_{OUT}+1V \leq V_{IN} \leq 36V$ | | 0.05 | 0.10 | %/V |
| $\Delta V_{OUT}/\Delta T_{opt}$ | Output Voltage Temperature Coefficient (*1) | $-40^{\circ}C \leq T_{opt} \leq 125^{\circ}C$ | | ± 50 | | ppm/ $^{\circ}C$ |
| I_{SINK1} | EXT Output Sink Current Limit | $V_{IN}=12V$, $V_{OUT}=V_{OUT}-0.2V$ | 9 | 14 | 20 | mA |
| I_{SINK2} | EXT Output Sink Current Limit (Output short) | $V_{IN}=12V$, $V_{OUT}=0V$ | 0.20 | 0.50 | 0.85 | mA |
| V_{ISENSE} | Current Limit Detector Threshold | | 0.23 | 0.30 | 0.37 | V |
| RR | Ripple Rejection | $V_{IN}=V_{OUT}+1V$, $f=1kHz$, $500mVp-p$ | | 55 | | dB |

*1) Depending on the capability of an external PNP transistor. Use an hFE with approximately 100 to 300. The output current does not always mean continuous current because of the limit of power dissipation of PNP transistor.

VD part

| Symbol | Item | Conditions | Min. | Typ. | Max. | Unit |
|----------------------------------|---|---|--------------------------|--------------------------|--------------------------|------------------|
| $-V_{DET}$ | Detector Threshold | | $\times 0.98$ | | $\times 1.02$ | V |
| V_{HYS} | Hysteresis Range | | $(-V_{DET}) \times 0.01$ | $(-V_{DET}) \times 0.02$ | $(-V_{DET}) \times 0.03$ | V |
| $\Delta -V_{DET}/\Delta T_{opt}$ | Detector Threshold Temperature Coefficient | $-40^{\circ}C \leq T_{opt} \leq 125^{\circ}C$ | | ± 50 | | ppm/ $^{\circ}C$ |
| V_{TCD} | C_D pin detector threshold | | 2.35 | 2.50 | 2.65 | V |
| I_{CD} | Internal Current value for Delay Time Setting | | 0.12 | 0.30 | 0.47 | μA |
| V_{INL} | Minimum Operating Voltage | V_{OUT} pin voltage | | | 2.0 | V |

WDT part

| Symbol | Item | Conditions | Min. | Typ. | Max. | Unit |
|------------|-------------------------|----------------------|----------------------|------|--------------|------|
| t_{WD} | Watchdog Timeout period | $C_{TW}=0.1\mu F$ | 200 | 300 | 510 | ms |
| t_{WR} | Reset Hold Time of WDT | $C_{TW}=0.1\mu F$ | 35 | 70 | 120 | ms |
| V_{IHCK} | SCK Input Voltage"H" | | $0.8 \times V_{OUT}$ | | $V_{DD}+0.3$ | V |
| V_{ILCK} | SCK Input Voltage"L" | | 0 | | 0.1 | V |
| T_{SCKW} | SCK Input Pulse Width | $-V_{DET} \geq 3.0V$ | 500 | | | ns |
| | | $-V_{DET} \leq 2.9V$ | 5000 | | | |

R5104V

(Unless otherwise specified, $V_{IN}=CE=V_{ISENSE}=12V$, $I_{OUT}=100mA$, $C_{CTW}=0.1\mu F$, $C_D=0.01\mu F$)

● R5104VxxxB (Overall)

$T_{opt}=25^{\circ}C$

| Symbol | Item | Conditions | Min. | Typ. | Max. | Unit |
|-----------|--------------------------|------------------------|------|------|--------------|---------|
| V_{IN} | Operating Voltage | | | | 36 | V |
| I_{SS} | Supply Current | $I_{OUT}=0mA$ | | 60 | 100 | μA |
| I_{off} | Supply Current (Standby) | $V_{IN}=12V$, $CE=0V$ | | 0.1 | 0.5 | μA |
| V_{CEH} | CE Input Voltage"H" | | 2.0 | | $V_{IN}+0.3$ | V |
| V_{CEL} | CE Input Voltage"L" | | 0 | | 0.25 | V |

VR part

| Symbol | Item | Conditions | Min. | Typ. | Max. | Unit |
|---|--|--|---------------|----------|---------------|------------------|
| V_{OUT} | Output Voltage | | $\times 0.98$ | | $\times 1.02$ | V |
| I_{OUT} | Output Current(*Note 1) | $V_{IN}=12V$ | 1.0 | | | A |
| V_{DIF} | Dropout Voltage(*Note 1) | $I_{OUT}=300mA$ | | 50 | | mV |
| $\Delta V_{OUT}/\Delta I_{OUT}$ | Load Regulation(*Note 1) | $V_{IN}=12V$, $1mA \leq I_{OUT} \leq 1A$ | | 15 | 60 | mV |
| $\frac{\Delta V_{OUT}}{\Delta V_{IN}}$ | Line Regulation(*Note 1) | $I_{OUT}=100mA$ $V_{OUT}+1V \leq V_{IN} \leq 36V$ | | 0.05 | 0.10 | %/V |
| $\frac{\Delta V_{OUT}}{\Delta T_{opt}}$ | Output Voltage Temperature Coefficient (*Note 1) | $-40^{\circ}C \leq T_{opt} \leq 125^{\circ}C$ | | ± 50 | | ppm/ $^{\circ}C$ |
| I_{SINK1} | EXT Output Sink Current Limit | $V_{IN}=12V$, $V_{OUT}=V_{OUT}-0.2V$ | 9 | 14 | 20 | mA |
| I_{SINK2} | EXT Output Sink Current Limit (Output short) | $V_{IN}=12V$, $V_{OUT}=0V$ | 0.20 | 0.50 | 0.85 | mA |
| V_{ISENSE} | Current Limit Detector Threshold | | 0.23 | 0.30 | 0.37 | V |
| RR | Ripple Rejection | $V_{IN}=V_{OUT}+1V$, $f=1kHz$, $500mVp-p$ | | 55 | | dB |

*1) Depending on the capability of an external PNP transistor. Use an hFE with approximately 100 to 300. The output current does not always mean continuous current because of the limit of power dissipation of PNP transistor.

VD part

| Symbol | Item | Conditions | Min. | Typ. | Max. | Unit |
|--|---|---|--------------------------|--------------------------|--------------------------|------------------|
| $-V_{DET}$ | Detector Threshold | | $\times 0.98$ | | $\times 1.02$ | V |
| V_{HYS} | Hysteresis Range | | $(-V_{DET}) \times 0.01$ | $(-V_{DET}) \times 0.02$ | $(-V_{DET}) \times 0.03$ | V |
| $\frac{\Delta -V_{DET}}{\Delta T_{opt}}$ | Detector Threshold Temperature Coefficient | $-40^{\circ}C \leq T_{opt} \leq 125^{\circ}C$ | | ± 50 | | ppm/ $^{\circ}C$ |
| V_{TCD} | C_D pin detector threshold | | 2.35 | 2.50 | 2.65 | V |
| I_{CD} | Internal Current value for Delay Time Setting | | 0.12 | 0.30 | 0.47 | μA |
| V_{INL} | Minimum Operating Voltage | V_{OUT} pin Voltage | | | 2.0 | V |

WDT part

| Symbol | Item | Conditions | Min. | Typ. | Max. | Unit |
|------------|-------------------------|----------------------|----------------------|------|--------------|------|
| t_{WD} | Watchdog Timeout period | $C_{TW}=0.1\mu F$ | 200 | 300 | 510 | ms |
| t_{WR} | Reset Hold Time of WDT | $C_{TW}=0.1\mu F$ | 35 | 70 | 130 | ms |
| V_{IHCK} | SCK Input Voltage"H" | | $0.8 \times V_{OUT}$ | | $V_{DD}+0.3$ | V |
| V_{ILCK} | SCK Input Voltage"L" | | 0 | | 0.1 | V |
| T_{SCKW} | SCK Input Pulse Width | $-V_{DET} \geq 3.0V$ | 500 | | | ns |
| | | $-V_{DET} \leq 2.9V$ | 5000 | | | |

(Unless otherwise specified, $V_{IN}=CE=V_{ISENSE}=12V$, $I_{OUT}=100mA$, $C_{CTW}=0.1\mu F$, $C_D=0.01\mu F$)

● R5104V007A (Overall)

$T_{opt}=25^{\circ}C$

| Symbol | Item | Conditions | Min. | Typ. | Max. | Unit |
|-----------|-------------------------------|------------------------|------|------|--------------|---------|
| V_{IN} | Operating Voltage | | | | 36 | V |
| I_{SS} | Supply Current | $I_{OUT}=0mA$ | | 45 | 80 | μA |
| I_{off} | Supply Current (WDT inactive) | $V_{IN}=12V$, $CE=0V$ | | 45 | 80 | μA |
| V_{CEH} | CE Input Voltage"H" | | 2.0 | | $V_{IN}+0.3$ | V |
| V_{CEL} | CE Input Voltage"L" | | 0.00 | | 0.25 | V |

VR part

| Symbol | Item | Conditions | Min. | Typ. | Max. | Unit |
|---------------------------------|--|--|---------------|----------|---------------|------------------|
| V_{OUT} | Output Voltage | | $\times 0.98$ | | $\times 1.02$ | V |
| I_{OUT} | Output Current(*1) | $V_{IN}=12V$ | 1.0 | | | A |
| V_{DIF} | Dropout Voltage(*1) | $I_{OUT}=300mA$ | | 50 | | mV |
| $\Delta V_{OUT}/\Delta I_{OUT}$ | Load Regulation(*1) | $V_{IN}=12V$, $1mA \leq I_{OUT} \leq 1A$ | | 15 | 60 | mV |
| $\Delta V_{OUT}/\Delta V_{IN}$ | Line Regulation(*1) | $I_{OUT}=100mA$ $V_{OUT}+1V \leq V_{IN} \leq 36V$ | | 0.05 | 0.10 | %/V |
| $\Delta V_{OUT}/\Delta T_{opt}$ | Output Voltage Temperature Coefficient (*1) | $-40^{\circ}C \leq T_{opt} \leq 125^{\circ}C$ | | ± 50 | | ppm/ $^{\circ}C$ |
| I_{SINK1} | EXT Output Sink Current Limit | $V_{IN}=12V$, $V_{OUT}=V_{OUT}-0.2V$ | 9 | 14 | 20 | mA |
| I_{SINK2} | EXT Output Sink Current Limit (Output short) | $V_{IN}=12V$, $V_{OUT}=0V$ | 0.20 | 0.50 | 0.85 | mA |
| V_{ISENSE} | Current Limit Detector Threshold | | 0.23 | 0.30 | 0.37 | V |
| RR | Ripple Rejection | $V_{IN}=V_{OUT}+1V$, $f=1kHz$, $500mVp-p$ | | 55 | | dB |

*1) Depending on the capability of an external PNP transistor. Use an hFE with approximately 100 to 300. The output current does not always mean continuous current because of the limit of power dissipation of PNP transistor.

VD part

| Symbol | Item | Conditions | Min. | Typ. | Max. | Unit |
|-----------------------------------|---|---|--------------------------|--------------------------|--------------------------|------------------|
| $-V_{DET}$ | Detector Threshold | | $\times 0.98$ | | $\times 1.02$ | V |
| V_{HYS} | Hysteresis Range | | $(-V_{DET}) \times 0.01$ | $(-V_{DET}) \times 0.02$ | $(-V_{DET}) \times 0.03$ | V |
| $\Delta(-V_{DET})/\Delta T_{opt}$ | Detector Threshold Temperature Coefficient | $-40^{\circ}C \leq T_{opt} \leq 125^{\circ}C$ | | ± 50 | | ppm/ $^{\circ}C$ |
| V_{TCD} | C_D pin detector threshold | | 2.35 | 2.50 | 2.65 | V |
| I_{CD} | Internal Current value for Delay Time Setting | | 0.12 | 0.30 | 0.47 | μA |
| V_{INL} | Minimum Operating Voltage | V_{OUT} pin Voltage | | | 2.0 | V |

WDT part

| Symbol | Item | Conditions | Min. | Typ. | Max. | Unit |
|------------|-------------------------|----------------------|----------------------|------|--------------|------|
| t_{WD} | Watchdog Timeout period | $C_{TW}=0.1\mu F$ | 200 | 300 | 510 | ms |
| t_{WR} | Reset Hold Time of WDT | $C_{TW}=0.1\mu F$ | 35 | 70 | 130 | ms |
| V_{IHCK} | SCK Input Voltage"H" | | $0.8 \times V_{OUT}$ | | $V_{DD}+0.3$ | V |
| V_{ILCK} | SCK Input Voltage"L" | | 0.0 | | 0.1 | V |
| T_{SCKW} | SCK Input Pulse Width | $-V_{DET} \geq 3.0V$ | 500 | | | ns |
| | | $-V_{DET} \leq 2.9V$ | 5000 | | | |

TIMING CHART

R5104VxxxA

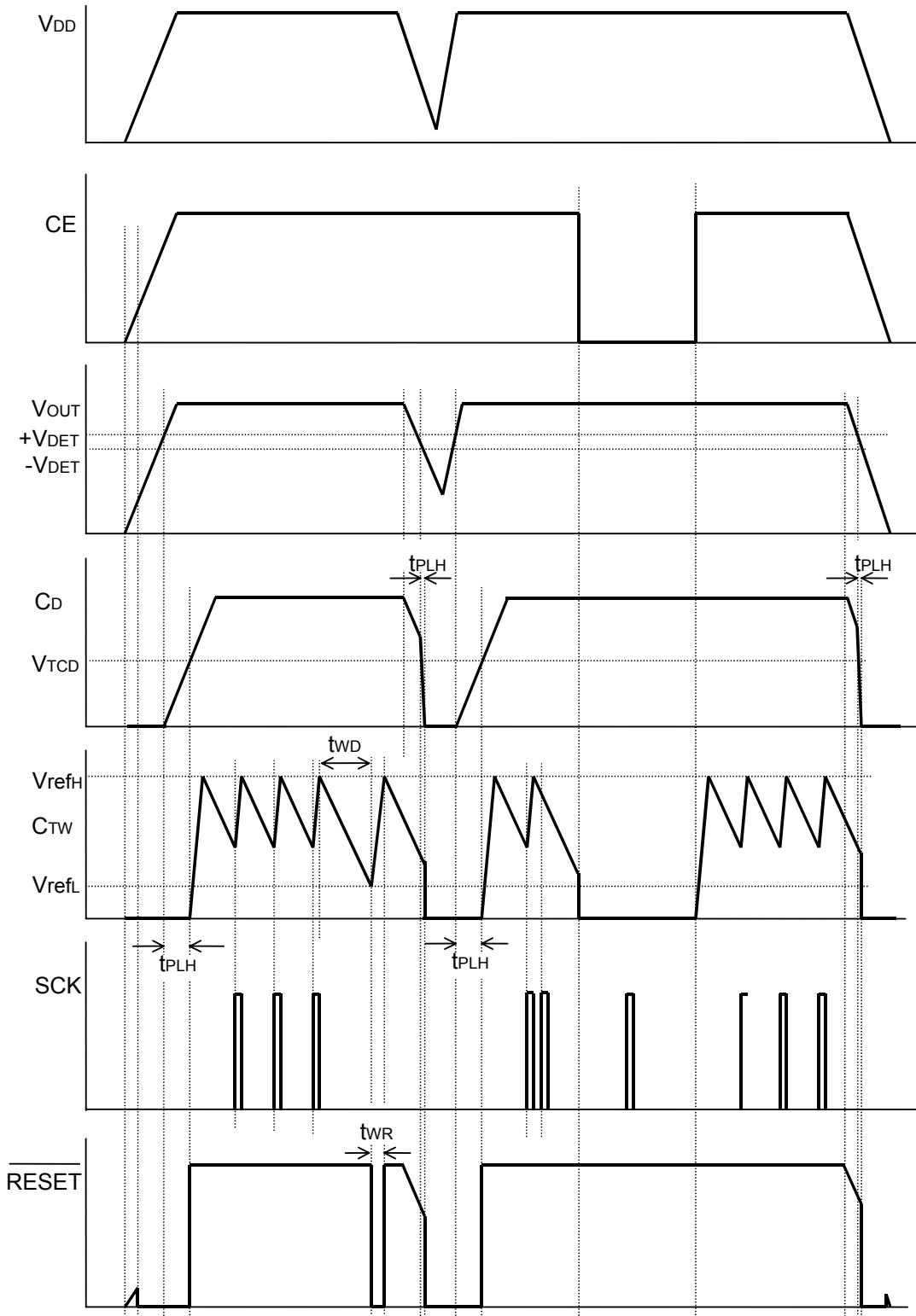

R5104VxxxB

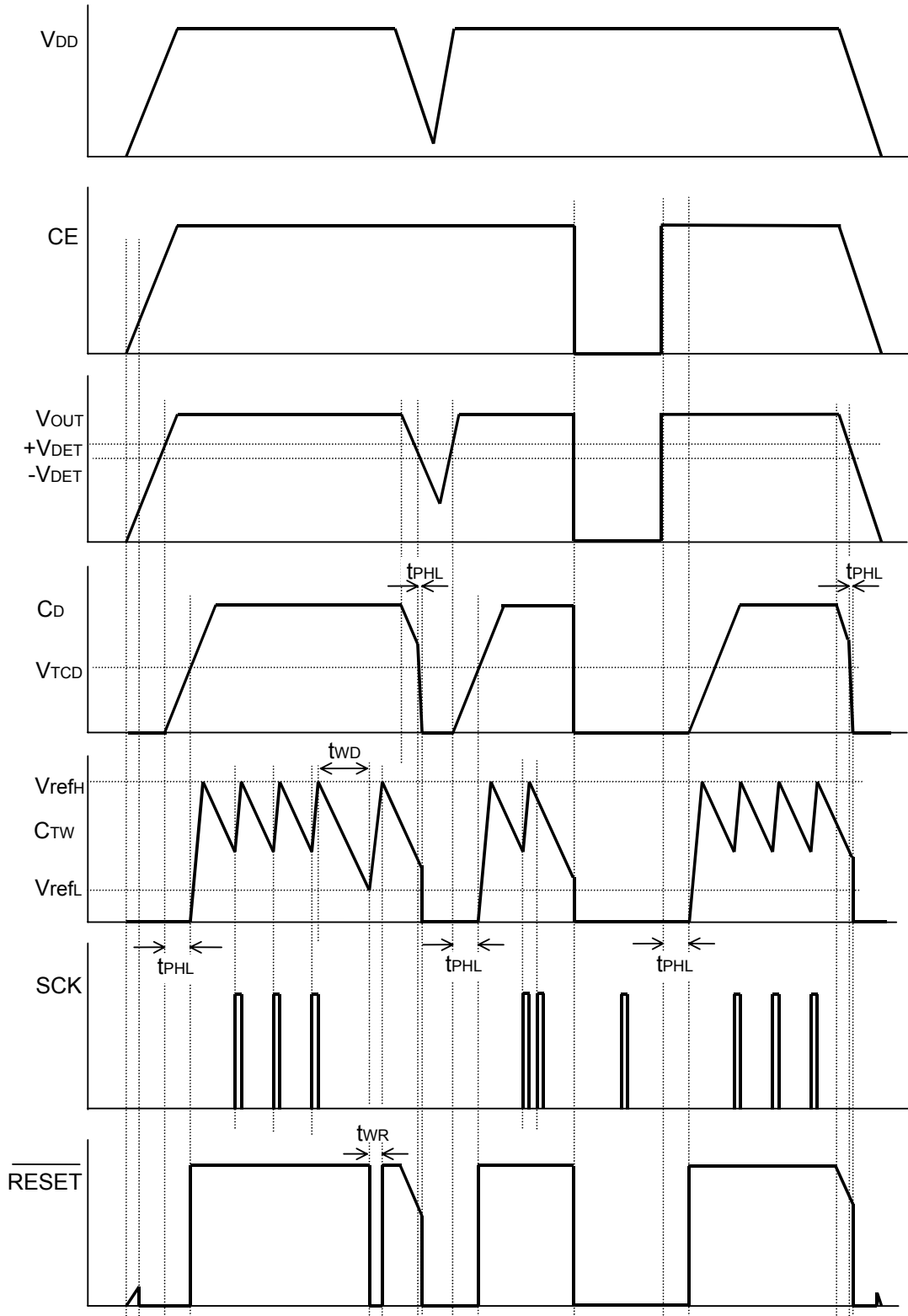

OPERATION

R5104VxxxA (Watchdog Timer On/Off type)

The R5104VxxxA have the function that turns off the clock input of the watchdog timer. When the watchdog timer is enabled (CE="H"), the output of the internal regulator and SCK input pulse are supervised, while the watchdog timer is disabled (CE="L"), only the regulator is supervised.

R5104VxxxB (Standby Function)

Since the standby function is included in the R5104VxxxB, the consumption current of the system can be reduced. The supply current at the standby mode is very small, typically 0.1μA.

Output Delay Time Setting of the built-in voltage detector

The released delay time from reset of the voltage detector (t_{PLH}) can be calculated with the external capacitor value C_D and the next formula.

$$t_{PLH} = V_{TCD} \times C_D / I_{CD} \text{ (S)}$$

On the other hand, output delay time for detecting voltage (t_{PHL}) is not specified, the time depends on the capacitance value of C_D .

TYPICAL APPLICATION

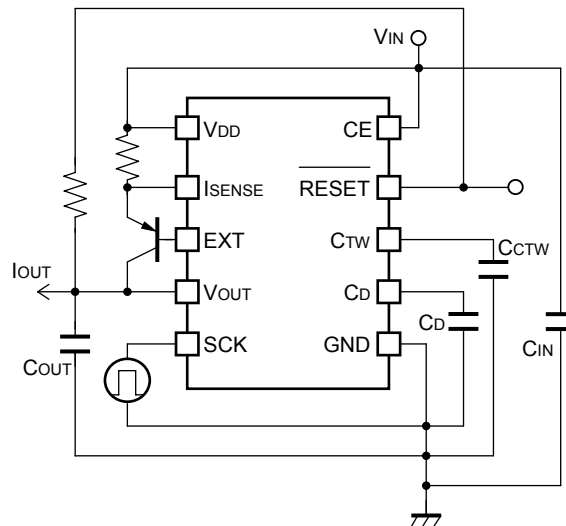

TEST CIRCUITS

Standard Test Circuit

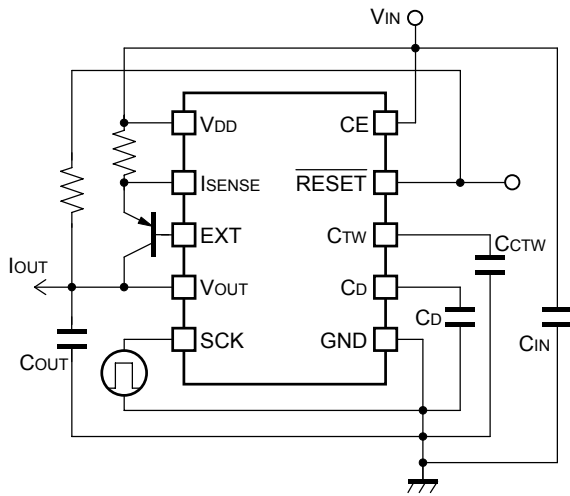

Supply Current Test Circuit

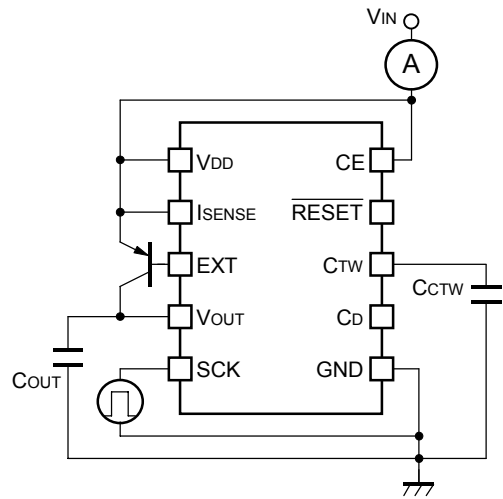

Standby Current Test Circuit

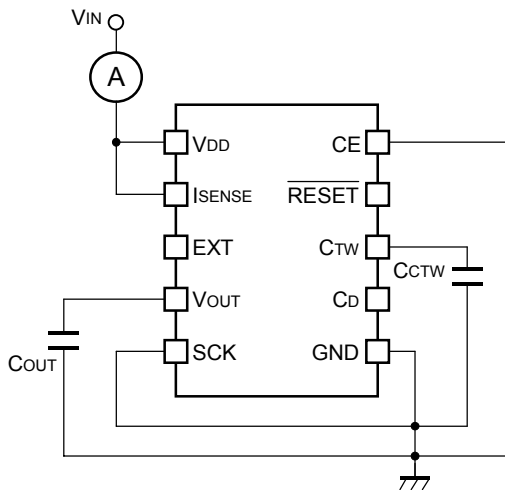

EXT Sink Current Test Circuit

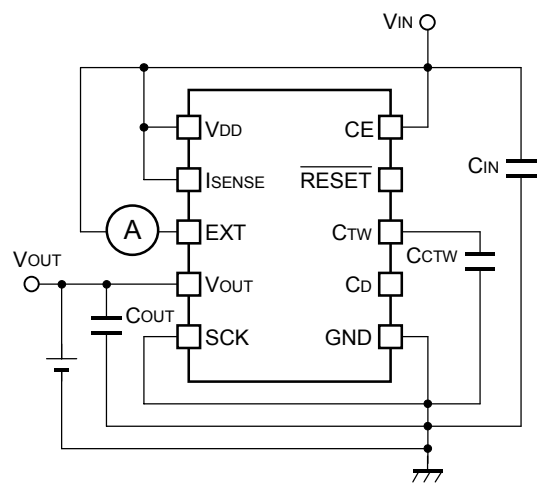

Ripple Rejection Test Circuit

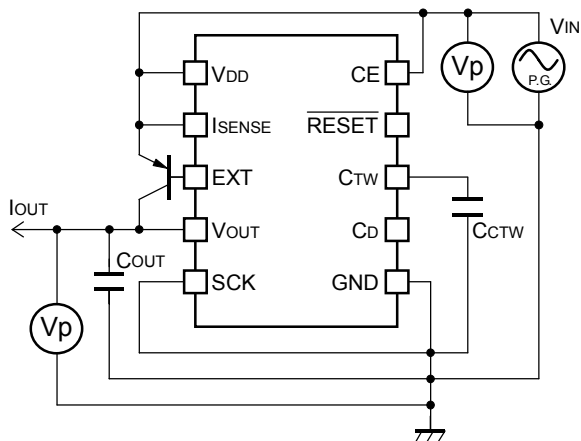

TYPICAL CHARACTERISTICS

(Unless otherwise provided, $V_{IN}=V_{ISENSE}=CE=12V$, $C_{IN}=0.1\mu F$, $C_{OUT}=10\mu F$, $C_{TW}=0.1\mu F$, $C_D=10\mu F$, $T_{opt}=25^\circ C$)

1) Output Voltage vs. Output Current

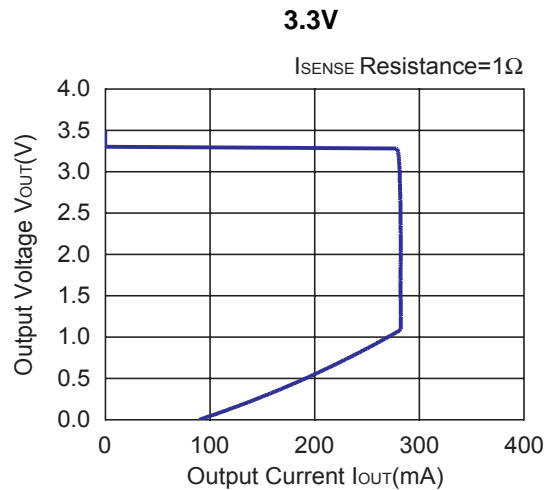
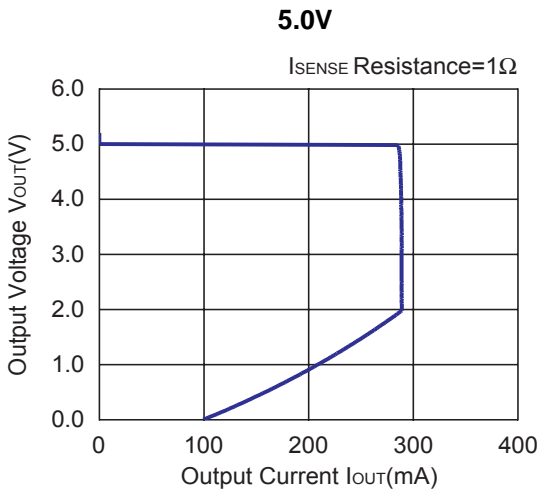
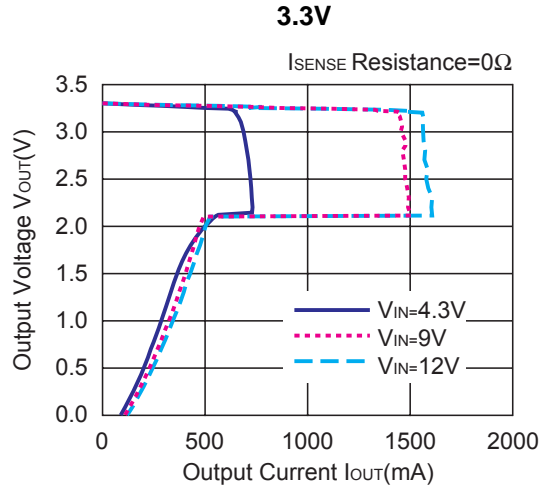
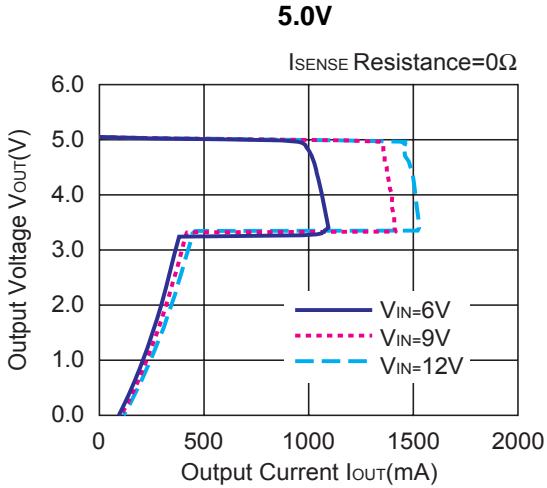

2) Output Voltage vs. Input Voltage

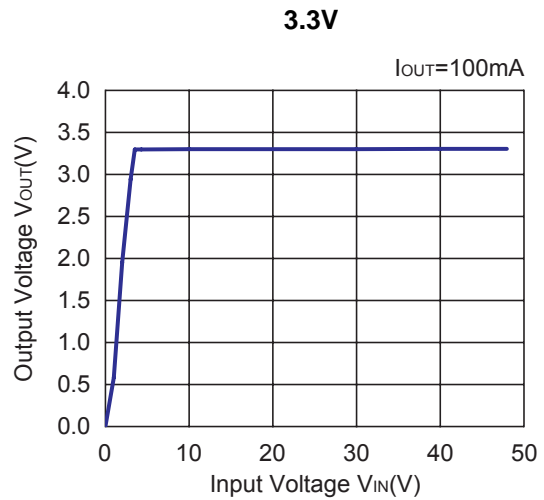
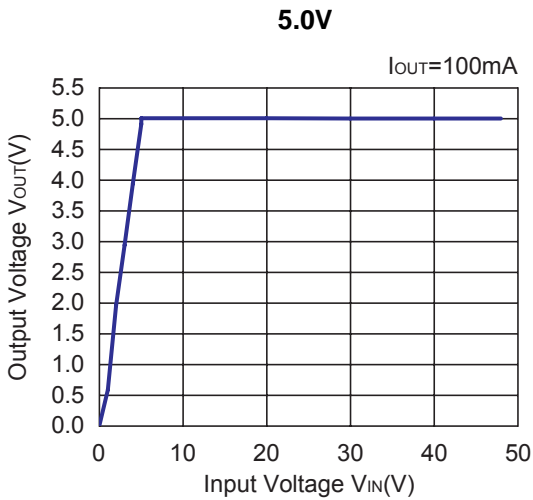

3) Output Voltage vs. Temperature

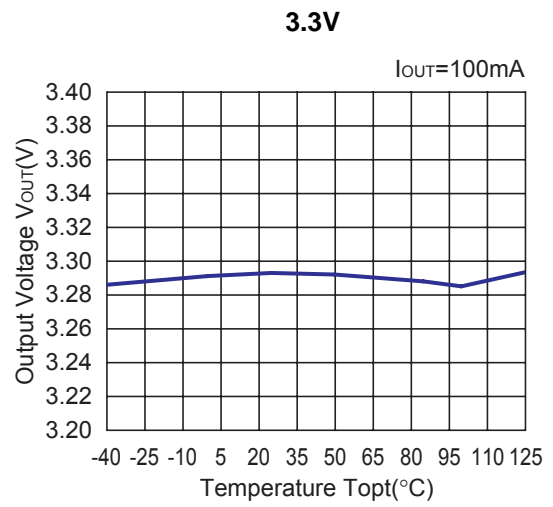
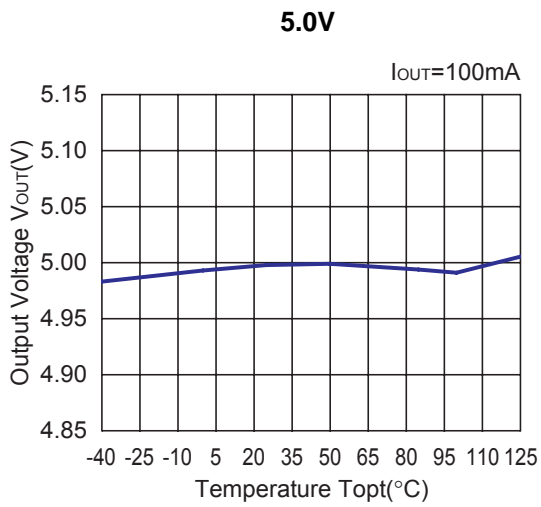

4) Base Current Limit vs. Output Voltage

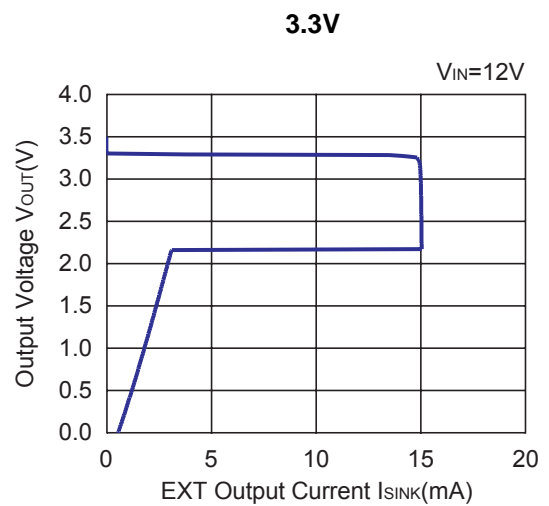
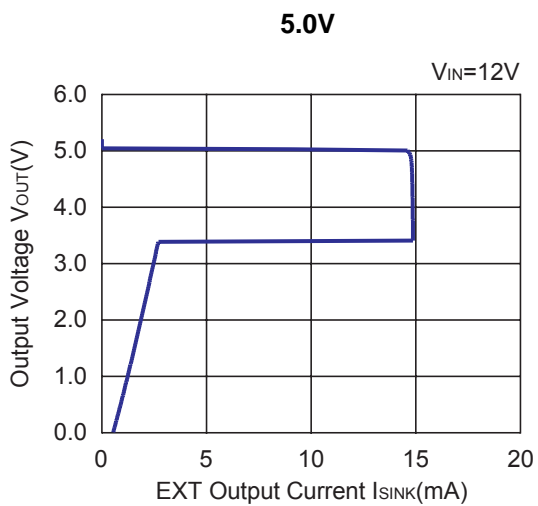

5) Ripple Rejection vs. Frequency

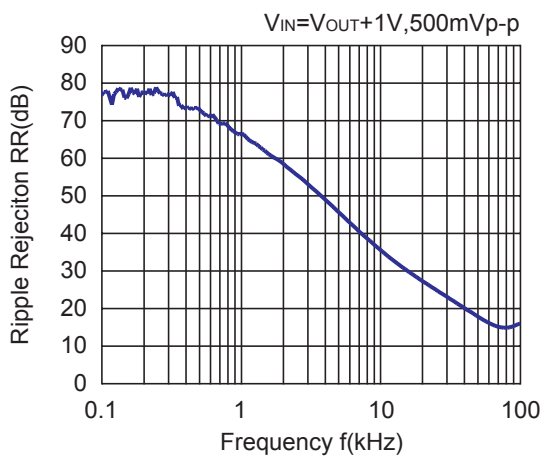

6) Input Transient Response

5.0V

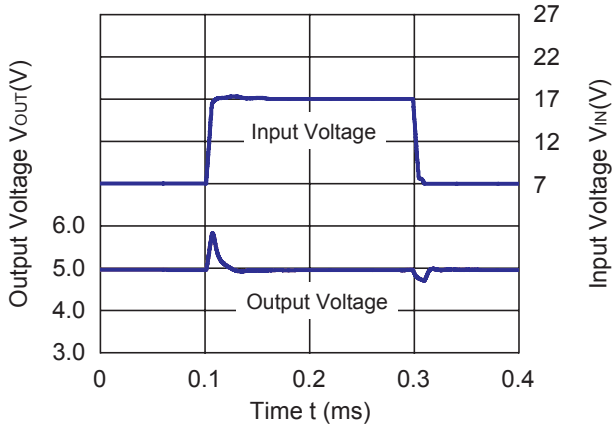

3.3V

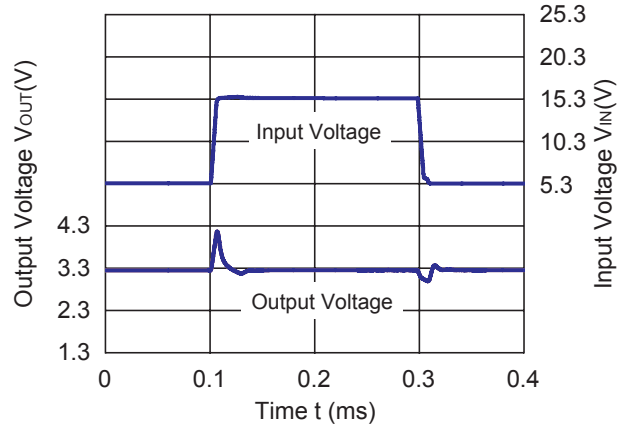

7) Load Transient Response

5.0V

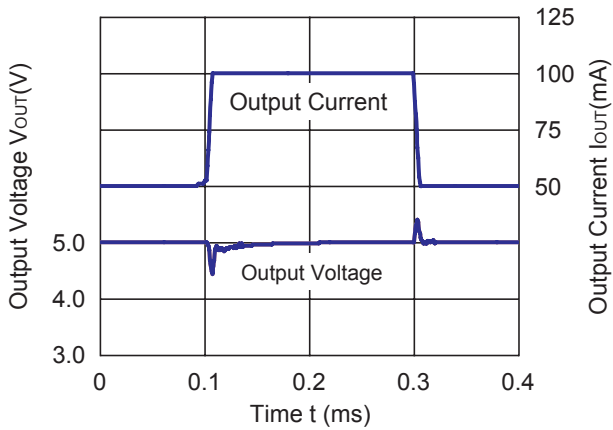

3.3V

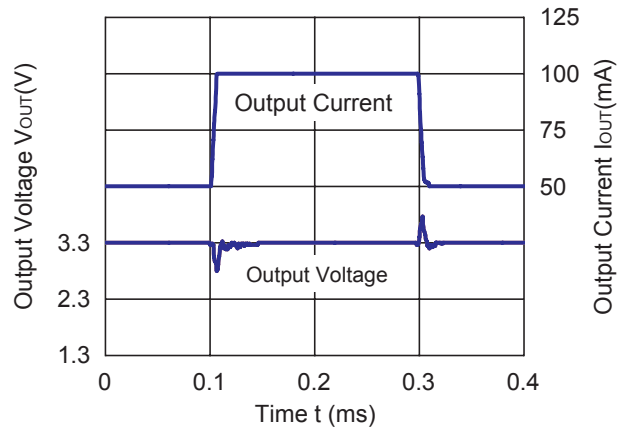

8) Detector Threshold vs. Temperature

4.0V

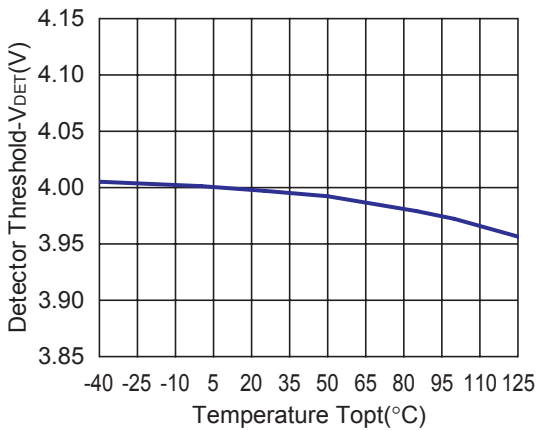

2.8V

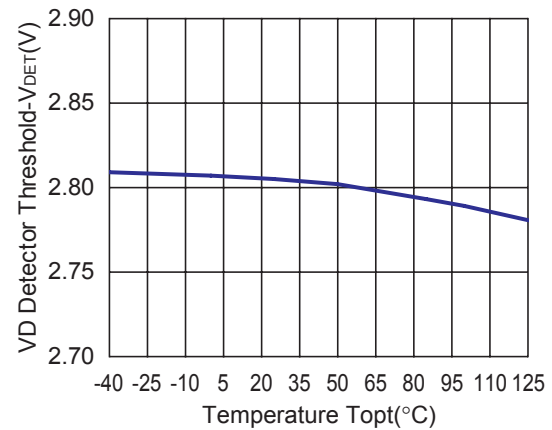

9) Output Voltage vs. Output Current

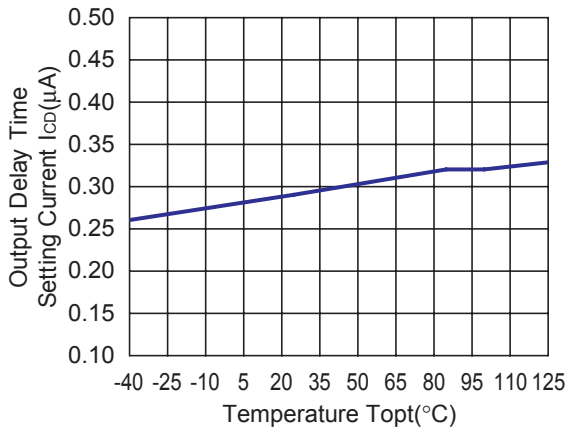

10) C_D Pin Threshold vs. Temperature

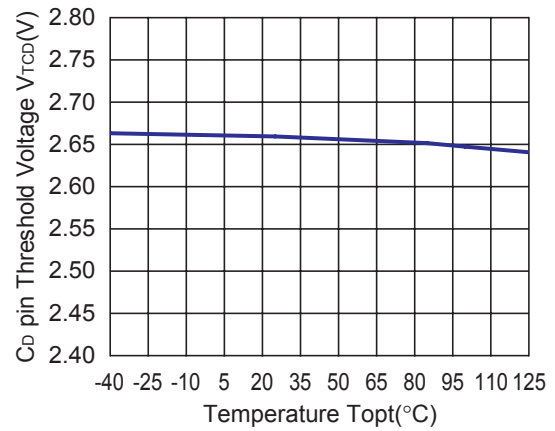

11) C_D Pin External Capacitance vs. Delay Time

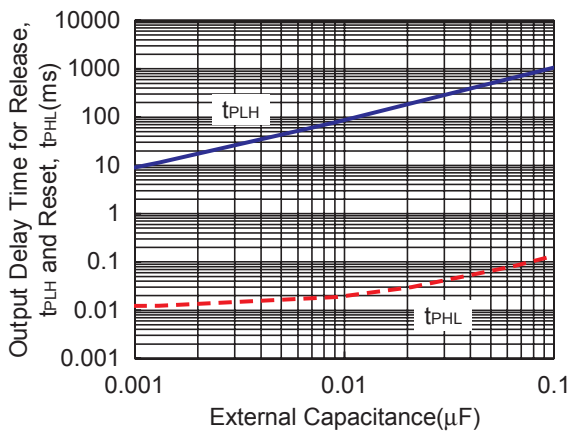

12) WDT monitoring Time vs. Temperature

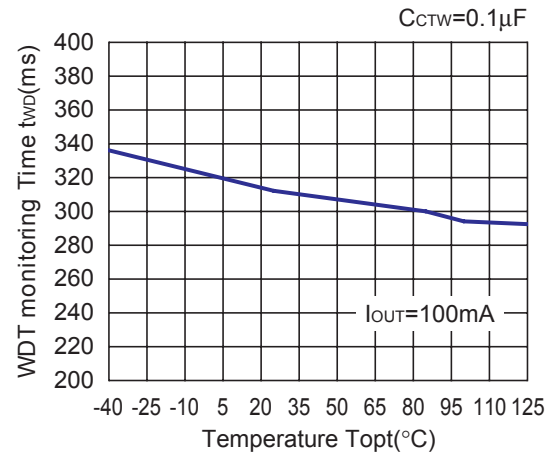

13) WDT Reset Time vs. Temperature

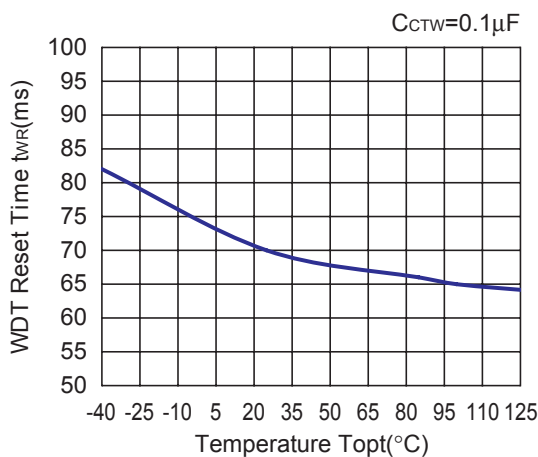

14) External Capacitance vs. WDT monitoring/Reset Time

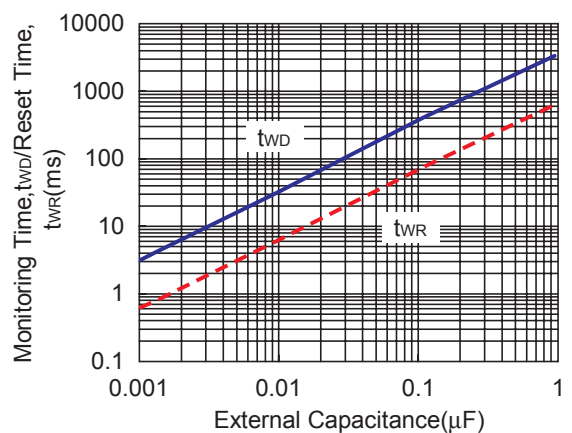

15) Supply Current vs. Temperature

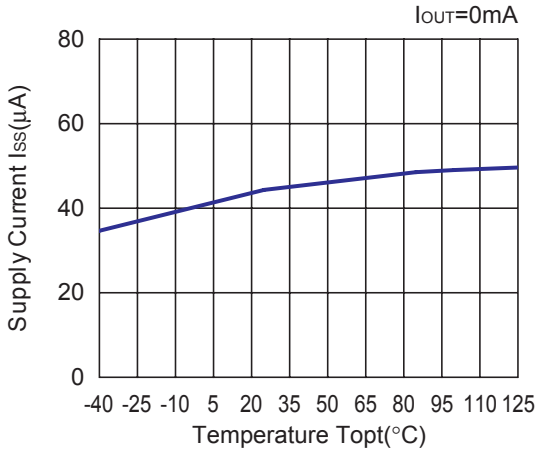

16) Supply Current vs. Input Voltage

5.0V

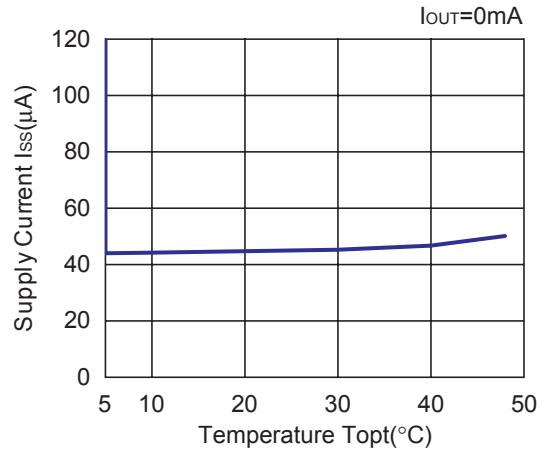

17) Current limit detector threshold vs. Temperature

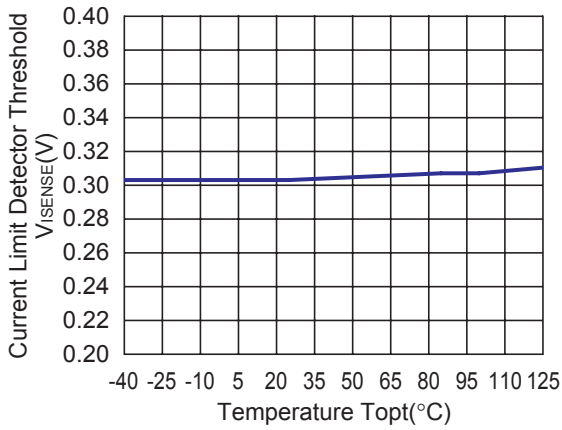

18) Nch Driver Output Current vs. V_{DS}

-V_{DET}=3.4V

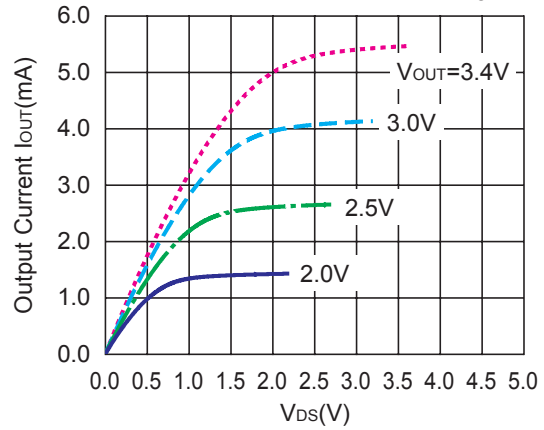

19) Nch Driver Output Current vs. V_{GS}

-V_{DET}=3.4V, RESET=0.05V

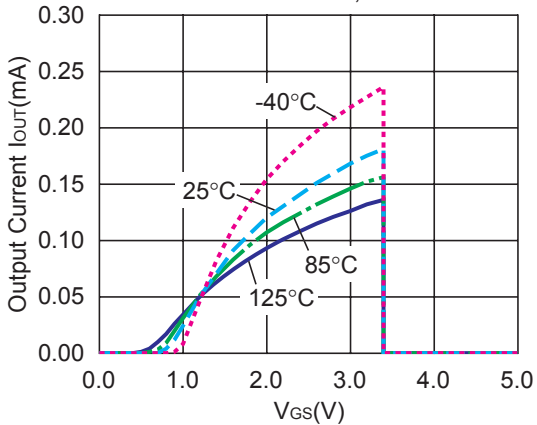

TECHNICAL NOTES

The phase compensation is made with the phase compensation circuit in the IC and the ESR of the output capacitor to make the operation stable. Therefore connect a 10 μ F or more value capacitor between V_{OUT} and GND. The ESR range of the output capacitor should be approximately 1 Ω to 10 Ω .

The fluctuation and the noise of the supply voltage, or a drastic change of the output voltage by the load transition of the regulator might be the reason of the mis-operation of the watchdog timer. If the SCK input pulse frequency is beyond 10kHz, or if the capacitance value of C_{TW} pin is large, the watchdog timer is easily affected by the fluctuation or noise of the supply voltage, or the fluctuation of the regulator output voltage, and it may cause an unstable operation.

If V_{IN} (supply voltage) may swing momentary, the regulator output is also swings. If the output of the voltage regulator becomes lower than detector voltage threshold, the built-in detector may generate the reset signal.

Built-in over-current limit works as monitoring the sink current of EXT pin and limits the current. Considering the over-current of the corrector current caused by short of EXT pin and GND externally, set a resistor between EXT pin and the base of the external driver transistor to limit the base current.

Use a 100pF or more value capacitor for C_{TW} pin.

Use a 10pF or more capacitor for C_D pin. A capacitor must be connected to C_D pin to use R5104VxxxA.

To avoid the mis-operation, during watchdog timer monitoring time, there is some ignoring time against clock pulse. Therefore, during the ignoring time, input clock pulse (rising edge trigger) is ignored. The ignoring time V_{REF2H} is approximately as follows:

The time interval for C_{TW} pin voltage from V_{REF2H} to V_{REF2H}-(V_{REF2H}-V_{REF2L})/4



1. The products and the product specifications described in this document are subject to change or discontinuation of production without notice for reasons such as improvement. Therefore, before deciding to use the products, please refer to Ricoh sales representatives for the latest information thereon.
2. The materials in this document may not be copied or otherwise reproduced in whole or in part without prior written consent of Ricoh.
3. Please be sure to take any necessary formalities under relevant laws or regulations before exporting or otherwise taking out of your country the products or the technical information described herein.
4. The technical information described in this document shows typical characteristics of and example application circuits for the products. The release of such information is not to be construed as a warranty of or a grant of license under Ricoh's or any third party's intellectual property rights or any other rights.
5. The products listed in this document are intended and designed for use as general electronic components in standard applications (office equipment, telecommunication equipment, measuring instruments, consumer electronic products, amusement equipment etc.). Those customers intending to use a product in an application requiring extreme quality and reliability, for example, in a highly specific application where the failure or misoperation of the product could result in human injury or death (aircraft, spacevehicle, nuclear reactor control system, traffic control system, automotive and transportation equipment, combustion equipment, safety devices, life support system etc.) should first contact us.
6. We are making our continuous effort to improve the quality and reliability of our products, but semiconductor products are likely to fail with certain probability. In order to prevent any injury to persons or damages to property resulting from such failure, customers should be careful enough to incorporate safety measures in their design, such as redundancy feature, firecontainment feature and fail-safe feature. We do not assume any liability or responsibility for any loss or damage arising from misuse or inappropriate use of the products.
7. Anti-radiation design is not implemented in the products described in this document.
8. Please contact Ricoh sales representatives should you have any questions or comments concerning the products or the technical information.

RICOH COMPANY., LTD. Electronic Devices Company



■ Ricoh presented with the Japan Management Quality Award for 1999.
Ricoh continually strives to promote customer satisfaction, and shares the achievements of its management quality improvement program with people and society.



■ Ricoh awarded ISO 14001 certification.
The Ricoh Group was awarded ISO 14001 certification, which is an international standard for environmental management systems, at both its domestic and overseas production facilities. Our current aim is to obtain ISO 14001 certification for all of our business offices.

<http://www.ricoh.com/LSI/>

RICOH COMPANY, LTD. Electronic Devices Company

● Higashi-Shinagawa Office (International Sales)
3-32-3, Higashi-Shinagawa, Shinagawa-ku, Tokyo 140-8655, Japan
Phone: +81-3-5479-2857 Fax: +81-3-5479-0502

RICOH EUROPE (NETHERLANDS) B.V.

● Semiconductor Support Centre
Prof. W.H.Keesomlaan 1, 1183 DL Amstelveen, The Netherlands
P.O.Box 114, 1180 AC Amstelveen
Phone: +31-20-5474-309 Fax: +31-20-5474-791

RICOH ELECTRONIC DEVICES KOREA Co., Ltd.

11 floor, Haesung 1 building, 942, Daechidong, Gangnamgu, Seoul, Korea
Phone: +82-2-2135-5700 Fax: +82-2-2135-5705

RICOH ELECTRONIC DEVICES SHANGHAI Co., Ltd.

Room403, No.2 Building, 690#Bi Bo Road, Pu Dong New district, Shanghai 201203,
People's Republic of China
Phone: +86-21-5027-3200 Fax: +86-21-5027-3299

RICOH COMPANY, LTD. Electronic Devices Company

● Taipei office
Room109, 10F-1, No.51, Hengyang Rd., Taipei City, Taiwan (R.O.C.)
Phone: +886-2-2313-1621/1622 Fax: +886-2-2313-1623



Ricoh completed the organization of the Lead-free production for all of our products. After Apr. 1, 2006, we will ship out the lead free products only. Thus, all products that will be shipped from now on comply with RoHS Directive.