Microprocessor power management with Watchdog Timer

NO. EA-071-130424

OUTLINE

The R5101G Series are CMOS-based μ con power management ICs with high accuracy output voltage and detector threshold and with ultra low supply current. Each of these ICs consists of a voltage regulator, a voltage detector and a watchdog timer. Thus, the R5101G Series have the function of a power management for microprocessor, a monitor of the voltage of a power source and a microprocessor supervisor.

The built-in voltage regulator with an internal driver transistor can supply typically 50mA current to a system when the voltage difference between input and output is 2V. Therefore these ICs are very suitable for various power supply systems for microprocessors. The output voltage is monitored by the voltage detector which is built-in these ICs.

The built-in voltage detector has an output delay function and the delay time can be set by an external capacitor (C_D).

The output voltage and the detector threshold voltage can be set individually for each IC by laser trimming.

Furthermore, when a microprocessor works incorrectly, the watchdog timer which checks over microprocessor generates reset signals intermittently to prevent a whole system from being malfunction.

The timeout periods for watchdog and reset can also be set individually by an external capacitor (C_{TW}).

FEATURES

- Built-in a watchdog timer
- Timeout period for watchdog and generating a reset signal can be set by an external capacitor
- Watchdog timer can be stopped individually by CE Pin
- Supply Current..... Typ. 5 μ A
- Output Voltage Range 1.8V to 5.0V (0.1V step)
- Output Voltage Accuracy $\pm 2.5\%$
- Detector Threshold Range..... 1.7V to 4.5V (0.1V step)
- Detector Threshold Accuracy..... $\pm 2.5\%$
- Power-on Reset Delay Time can be set by an external capacitor
- Output Current Typ. 50mA (at $V_{IN}-V_{OUT}=2V$)
- Package SSOP-8G

APPLICATIONS

- Power source for microprocessors

BLOCK DIAGRAMS

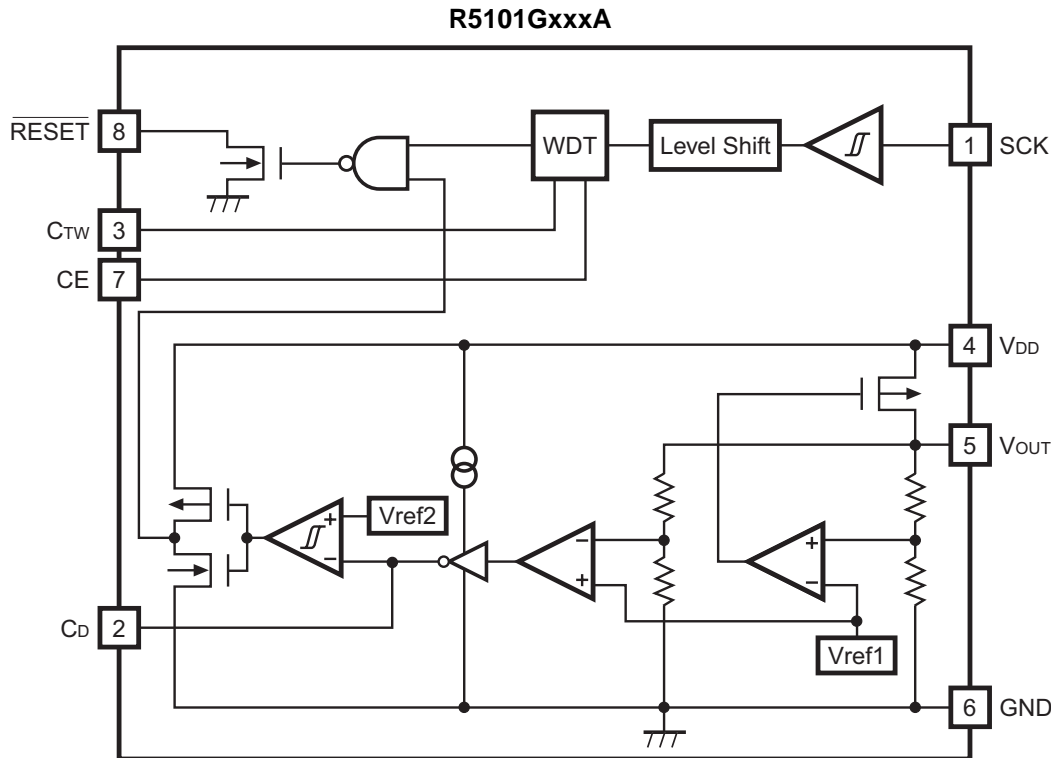

SELECTION GUIDE

The output voltage and the detector threshold for the ICs can be selected at the users' request.

Product Name	Package	Quantity per Reel	Pb Free	Halogen Free
R5101GxxxA-TR-FE	SSOP-8G	3,000 pcs	Yes	Yes

xxx: The combination of output voltage and detector threshold for each channel can be designated by serial numbers.
 (For details, please refer to MARK INFORMATIONS.)

PIN CONFIGURATION

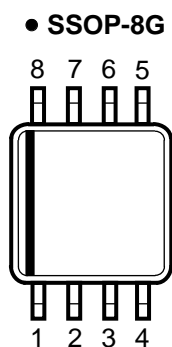

PIN DESCRIPTIONS

Pin No.	Symbol	Description
1	SCK	Clock Input Pin from Microprocessor
2	C _D	External Capacitor Pin for Setting Delay Time of Voltage Detector
3	C _{TW}	External Capacitor Pin for Setting Reset and Watchdog Timeout Periods
4	V _{DD}	Power supply Pin
5	V _{OUT}	Output Pin for Voltage Regulator
6	GND	Ground Pin
7	CE	Control Switch Pin for Watchdog timer ("H" active, "L" inactive)
8	$\overline{\text{RESET}}$	Output Pin for Reset signal of Watchdog timer and Voltage Detector. (Output Type is Nch Open Drain, Output "L" at detecting Detector Threshold and Watchdog Timer Reset.)

ABSOLUTE MAXIMUM RATINGS

T_{opt}=25°C, V_{SS}=0V

Symbol	Item	Rating	Unit
V _{DD}	Supply Voltage	-0.3 to 12	V
V _{CD}	Output Voltage	Voltage of C _D Pin	V _{SS} -0.3 to V _{DD} +0.3
V _{CTW}		Voltage of C _{TW} Pin	V _{SS} -0.3 to V _{DD} +0.3
V _{OUT}		Voltage of V _{OUT} Pin	V _{SS} -0.3 to V _{DD} +0.3
V _{RESET}		Voltage of $\overline{\text{RESET}}$ Pin	V _{SS} -0.3 to 12
V _{CE}	Input Voltage	Voltage of CE Pin	V _{SS} -0.3 to V _{DD} +0.3
V _{SCK}		Voltage of SCK Pin	V _{SS} -0.3 to V _{DD} +0.3
I _{OUT}	Output Current	Current of V _{OUT} Pin	150
I _{RESET}		Current of $\overline{\text{RESET}}$ Pin	10
P _D	Power Dissipation (SSOP-8G)*	380	mW
T _{opt}	Operating Temperature Range	-40 to 85	°C
T _{stg}	Storage Temperature Range	-55 to 125	°C

*) For Power Dissipation, please refer to PACKAGE INFORMATION.

ABSOLUTE MAXIMUM RATINGS

Electronic and mechanical stress momentarily exceeded absolute maximum ratings may cause the permanent damages and may degrade the life time and safety for both device and system using the device in the field.

The functional operation at or over these absolute maximum ratings is not assured.

ELECTRICAL CHARACTERISTICS

• R5101GxxxA

T_{opt}=25°C

Symbol	Item	Conditions	Min.	Typ.	Max.	Unit
V _{DD}	Operating Voltage		1.5		10	V
I _{SS-On}	Supply Current (WDT active)	V _{DD} =CE=V _{OUT} +2.0V		5	15	μA
I _{SS-Off}	Supply Current (WDT inactive)	V _{DD} =V _{OUT} +2.0V, CE=GND		6	18	μA
V _{OUT}	Output Voltage	V _{DD} =V _{OUT} +2.0V, I _{OUT} =10mA	×0.975		×1.025	V
I _{OUT}	Output Current *1	V _{DD} =V _{OUT} +2.0V	50			mA
V _{DIF}	Dropout Voltage	Refer to the following table				
ΔV _{OUT} / ΔI _{OUT}	Load Regulation	V _{DD} =V _{OUT} +2.0V, 1mA≤I _{OUT} ≤30mA (In case that 3.0V≤V _{OUT} ≤5.0V, 1mA≤I _{OUT} ≤50mA)		50	100	mV
ΔV _{OUT} / ΔV _{DD}	Line Regulation	I _{OUT} =10mA V _{OUT} +0.5V≤V _{DD} ≤10V		0.1	0.2	%/V
I _{LIM}	Current Limit (Short mode)	V _{OUT} =GND	10	50	100	mA
ΔV _{OUT} / ΔT _{opt}	Output Voltage Temperature Coefficient	I _{OUT} =10mA -40°C≤T _{opt} ≤85°C		±100		ppm/ °C
-V _{DET}	Detector Threshold		×0.975		×1.025	V
V _{HYS}	Hysteresis Range		-V _{DET} ×0.03	-V _{DET} ×0.05	-V _{DET} ×0.07	V
V _{DETMGN}	Regulator Voltage Margin against Released Voltage	V _{OUT} -((-V _{DET})+V _{HYS}), I _{OUT} =10mA	0.02			V
Δ-V _{DET} / ΔT _{opt}	Detector Threshold Temperature Coefficient	-40°C≤T _{opt} ≤85°C		±100		ppm/ °C
t _{PR}	Reset Delay Time	V _{DD} =V _{OUT} +2.0V, C _D =0.001μF	7	14	35	ms
t _{WD}	Watchdog Timeout period	V _{DD} =V _{OUT} +2.0V, C _W =0.01μF	50	120	250	ms
t _{WR}	Reset Hold Time of WDT	V _{DD} =V _{OUT} +2.0V, C _W =0.01μF	5	12	25	ms
V _{IHSCK}	SCK Input Voltage "H"	V _{DD} =V _{OUT} +2.0V	0.8 ×V _{OUT}		V _{DD}	V
V _{ILSCK}	SCK Input Voltage "L"	V _{DD} =V _{OUT} +2.0V	1.8V≤V _{OUT} ≤2.9V	0	0.1 ×V _{OUT}	V
			3.0V≤V _{OUT} ≤5.0V	0	0.2 ×V _{OUT}	
V _{IHCE}	CE Input Voltage "H"		1.2		V _{DD}	V
V _{ILCE}	CE Input Voltage "L"		0.0		0.2	V
I _{IHSCK}	SCK Input Current "H"	V _{DD} =SCK=V _{OUT} +2.0V	-1		1	μA
I _{ILSCK}	SCK Input Current "L"	V _{DD} =V _{OUT} +2.0V, SCK=GND	-1		1	μA
R _{PU}	CE Pull-up Resistance		2	4	10	MΩ
I _{CD}	C _D Pin Output Current	V _{DD} =1.5V, V _{DS} =0.5V	1	2		mA
I _{CTW}	C _{TW} Pin Output Current	V _{DD} =1.5V, V _{DS} =0.5V	1	2		mA
I _{RESET}	RESET Pin Output Current	V _{DD} =1.5V, V _{DS} =0.5V	1	2		mA
I _{leak}	RESET Pin Leakage Current	V _{DD} =10.0V, CE=GND, V _{DS} =10.0V	-1		1	μA
T _{SCKW}	SCK Input Pulse Width	V _{DD} =V _{OUT} +2.0V	500			ns

R5101G

Symbol	Item	Conditions	Min.	Typ.	Max.	Unit
V _{start}	Minimum Operating Voltage of Voltage Detector			0.9	1.5	V

*1) In case that $V_{OUT} < 2V$, please use I_{OUT} with 0.1mA or more.

• Dropout Voltage by Output Voltage

T_{opt}=25°C

Output Voltage V _{OUT} (V)	Dropout Voltage V _{DIF} (V)			
	Condition	Min.	Typ.	Max.
$1.8 \leq V_{OUT} \leq 2.9$	I _{OUT} =10mA	0.100	0.350	0.650
$3.0 \leq V_{OUT} \leq 3.9$	I _{OUT} =30mA	0.100	0.500	0.850
$4.0 \leq V_{OUT} \leq 5.0$		0.100	0.350	0.650

RECOMMENDED OPERATING CONDITIONS (ELECTRICAL CHARACTERISTICS)

All of electronic equipment should be designed that the mounted semiconductor devices operate within the recommended operating conditions. The semiconductor devices cannot operate normally over the recommended operating conditions, even if when they are used over such conditions by momentary electronic noise or surge. And the semiconductor devices may receive serious damage when they continue to operate over the recommended operating conditions.

TYPICAL APPLICATIONS

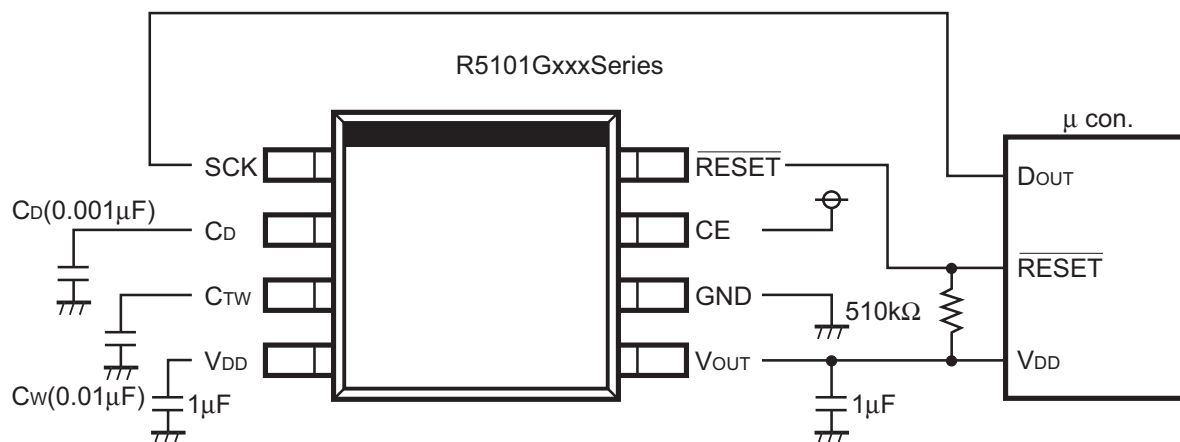

TECHNICAL NOTES

The minimum value of the operation margin for releasing the voltage detector is specified as 0.02V.

This IC is sensing the output voltage of the regulator of this IC itself, and depending on the input voltage transient or load transient, the operation margin may be disappeared.

The power line noise may cause a mis-operation of the watchdog timer, therefore V_{DD} and GND lines must be sufficient enough for avoiding the mis-operation.

If the power line has some noise, the output of the regulator of this IC may generate the noise, in such a case, the built-in detector may detect the output noise of the voltage regulator and $\overline{\text{RESET}}$ signal may output.

To prevent the IC from this kind of mis-operation, we recommend using a capacitor in the capacitance range from $1\mu\text{F}$ to $2.2\mu\text{F}$ between V_{OUT} pin and GND pin.

To avoid the mis-operation, during watchdog timer monitoring time, there is some ignoring time against clock pulse. Therefore, during the ignoring time, input clock pulse (rising edge trigger) is ignored. The ignoring time is approximately as follows:

- 1) The time interval for V_{CTW} pin voltage from V_{ref2H} to $(V_{ref2H} - V_{ref2H}/20)$
- 2) The time interval for V_{CTW} pin voltage from $V_{ref2L} + V_{ref2L}/20$ to V_{ref2L}

TIMING CHART

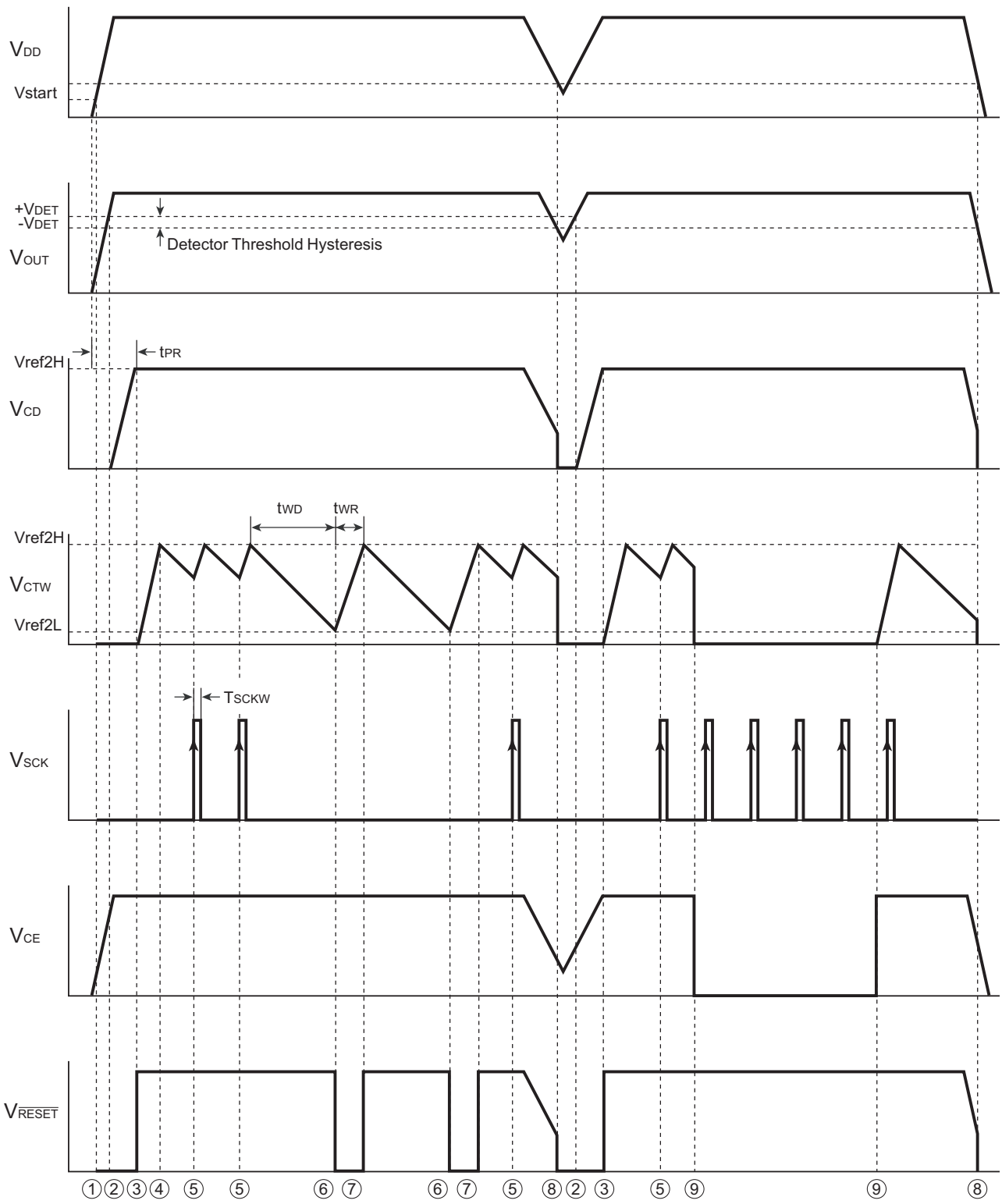

OPERATION

- ① When V_{DD} is turned on and Input Voltage reaches V_{start} (nearly equal 0.8V), the output of \overline{RESET} pin becomes "L" level.
- ② An External Capacitor starts to be charged through the C_D pin when an Output Voltage of the Voltage Regulator, V_{OUT} , crosses the Released Voltage, $+V_{DET}$, from Lower to Higher. The $\overline{V_{RESET}}$ is kept "L" level until Voltage of the C_D pin, V_{CD} , reaches to the V_{ref2H} , and after that the $\overline{V_{RESET}}$ becomes to "H" level.
 - * t_{PR} : Time interval between the timing of starting edge of forcing voltage to V_{DD} pin and the timing of reverse the voltage level of $\overline{V_{RESET}}$.
 t_{PR} can be set by connecting an external capacitor to C_D pin, t_{PR} can be calculated as shown below;
 $t_{PR}(ms) \approx 14000 \times C_D(\mu F)$; C_D means a value of an external capacitor connected to C_D pin.
- ③ When the voltage level of V_{CD} reaches to the V_{ref2H} , the external capacitor starts to be charged through the C_{TW} pin and the watchdog timer begins to operate.
- ④ The operation mode for the external capacitor changes from charging mode to discharging mode through C_{TW} pin when the voltage level of C_{TW} pin, V_{CTW} , reaches to the V_{ref2H} .
- ⑤ While the C_{TW} pin is on the discharging mode, if a clock pulse is entered (synchronous with a rising edge of the pulse), the operation mode of C_{TW} pin changes from discharging mode to charging mode. And the external capacitor connected to C_{TW} pin is charged until its voltage level reaches to V_{ref2H} .
- ⑥ While the C_{TW} pin is on the discharging mode, if V_{CTW} level drops to V_{ref2L} without clock pulse to CLK pin, the voltage level of \overline{RESET} pin becomes from "H" to "L".
 - * Watchdog Timeout period, t_{WD} ,: Discharging Time of C_{TW} pin level from V_{ref2H} to V_{ref2L}
 t_{WD} can be set by connecting an external capacitor to C_W pin, t_{WD} can be calculated as shown below;
 $t_{WD}(ms) \approx 12000 \times C_W(\mu F)$; C_W means a value of an external capacitor connected to C_W pin.
- ⑦ C_{TW} pin is changed to charging mode from discharging mode when the Reset signal is generated.
 - * Reset timeout period of the watchdog timer, t_{WR} ,: Time interval between Charging time of the C_{TW} pin from V_{ref2L} to V_{ref2H} . t_{WR} can be calculated by the next equation as shown below;
 $t_{WR}(ms) \approx t_{WD}/10$
- ⑧ The Output Voltage level of \overline{RESET} pin becomes from "H" to "L", or a Reset signal is generated when an output voltage of the Voltage Regulator drops to a level at equal or less than $-V_{DET}$.
- ⑨ The watchdog timer will be halted when a Voltage level of CE pin becomes to "L". In this case, only the watchdog timer is stopped and monitoring the output voltage is continued. After that, if the voltage level of CE pin becomes to "H", C_{TW} pin starts to be on charging mode.

TEST CIRCUIT

Supply Current Test Circuit

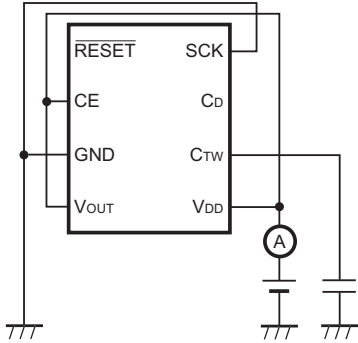

Output Voltage Test Circuit

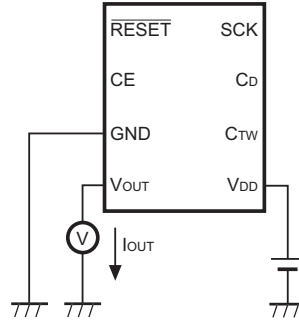

Detector Threshold (V_{DET}) Test Circuit

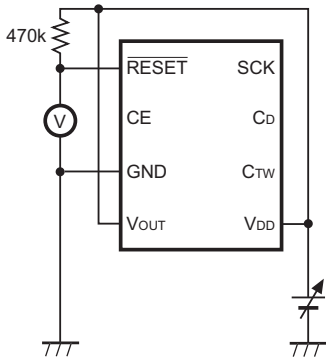

Reset and Watchdog Timeout Periods Test Circuit

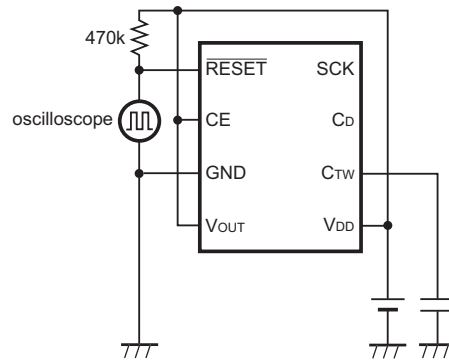

SCK Input Current Test Circuit

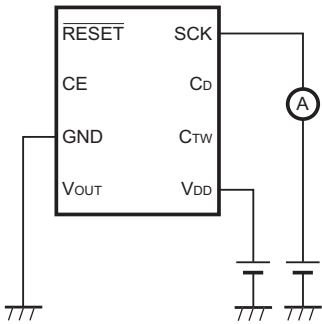

Output Current Test Circuit

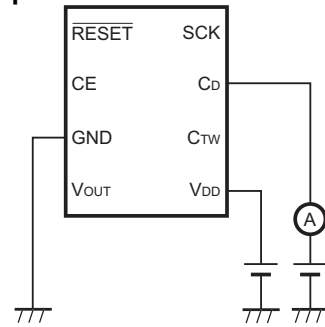

RESET Output leakage Current Test Circuit

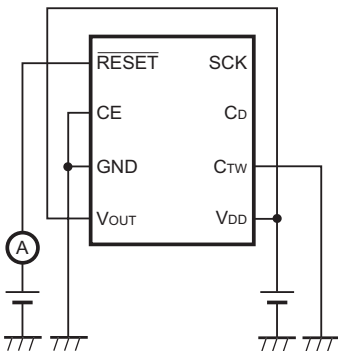

Minimum Input Voltage for RESET Output Test Circuit

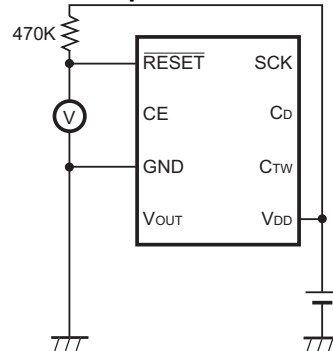

TYPICAL CHARACTERISTICS

1) Output Voltage vs. Output Current

R5101G (VR=3V)

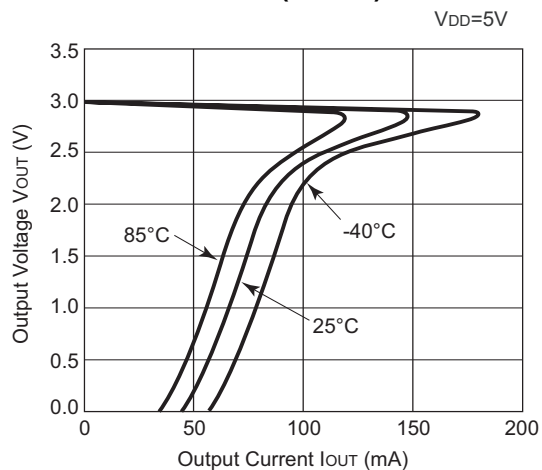

R5101G (VR=5V)

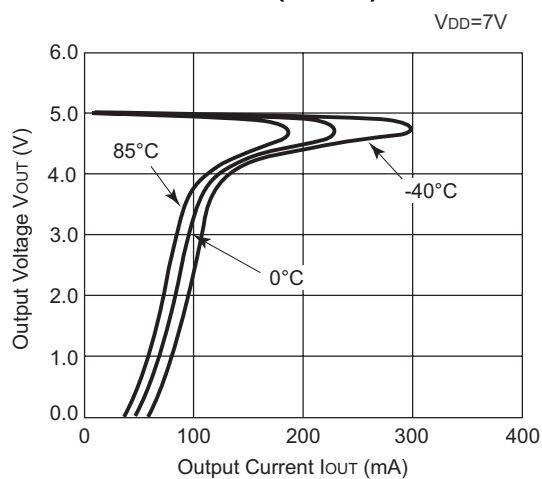

2) Output Voltage vs. Input Voltage

R5101G (VR=3V)

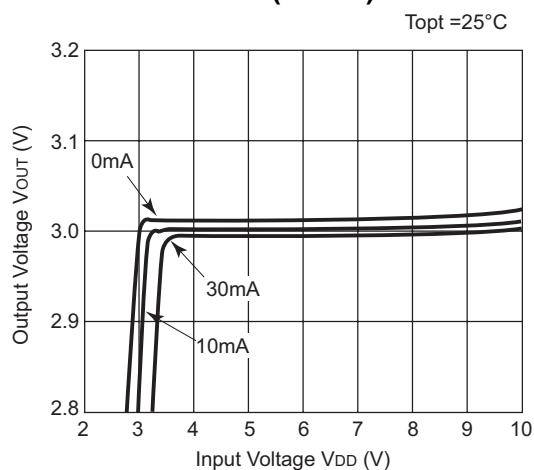

R5101G (VR=5V)

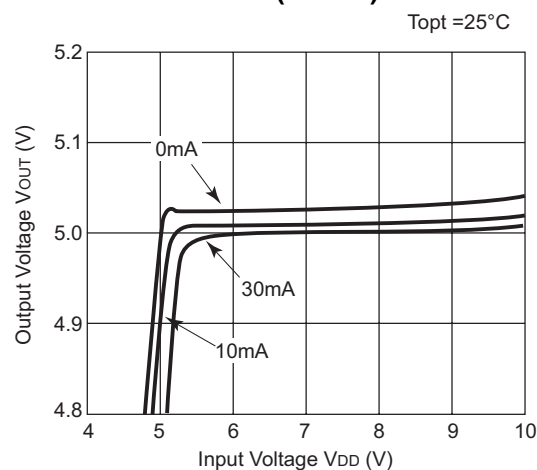

3) Dropout Voltage vs. Output Current

R5101G (VR=3V)

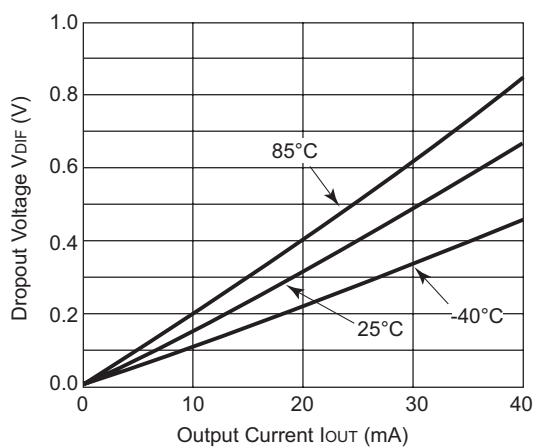

R5101G (VR=5V)

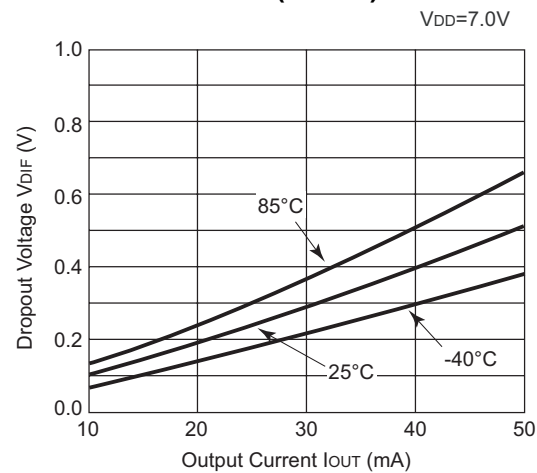

R5101G

4) Output Voltage vs. Temperature

R5101G (VR=3V)

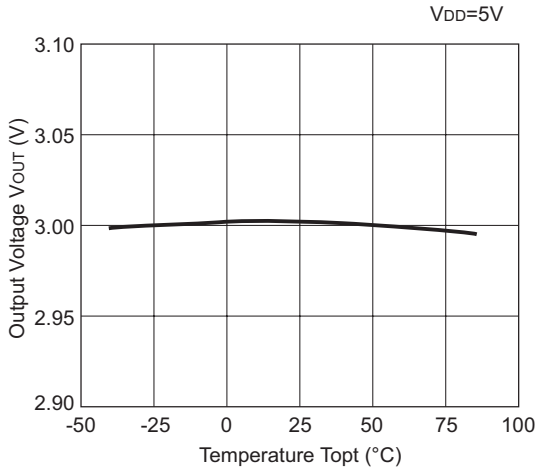

R5101G (VR=5V)

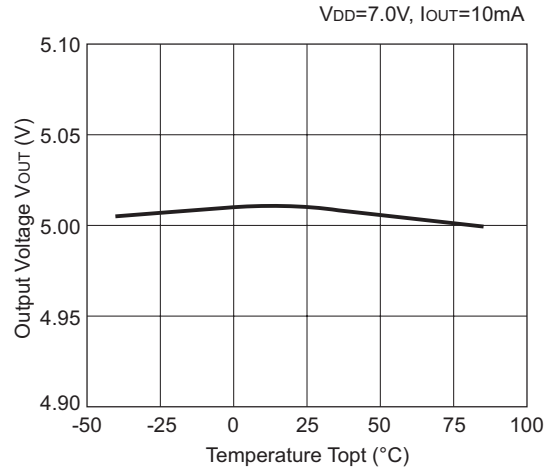

5) RESET Pin Voltage vs. Input Voltage

R5101G (VD=2.7V)

Pull-up 510kΩ

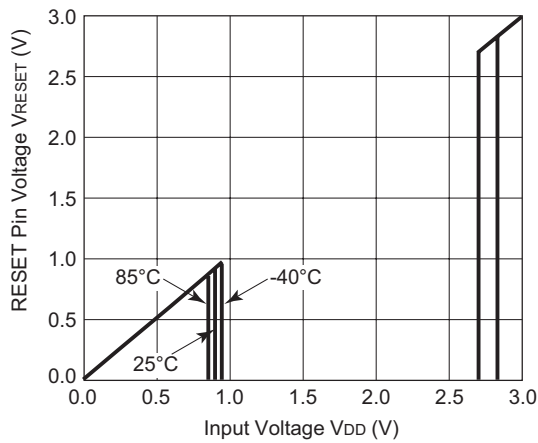

6) Detector Threshold vs. Temperature

R5101G (VD=2.7V)

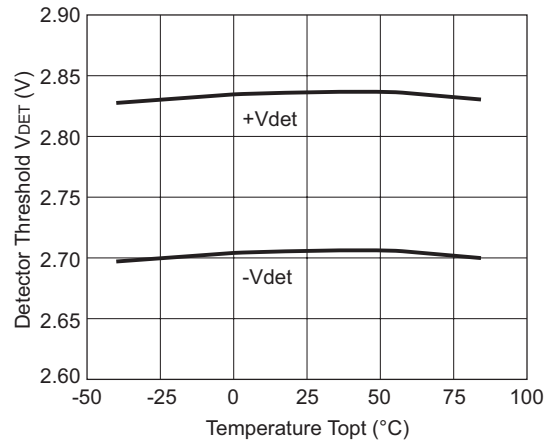

7) C_D Pin Output Current vs. Input Voltage

R5101G (VD=2.7V)

V_{DS}=0.5V

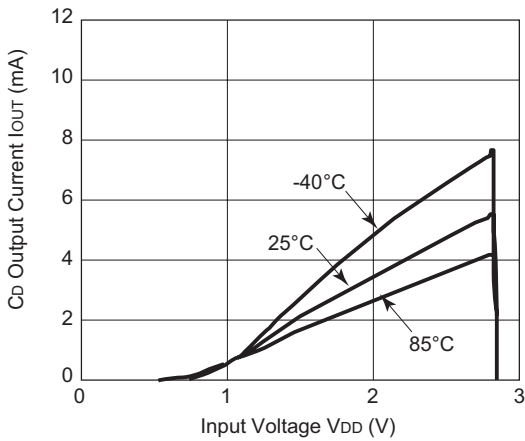

8) C_{TW} Pin Output Current vs. Input Voltage

R5101G (VD=2.7V)

V_{DS}=0.5V

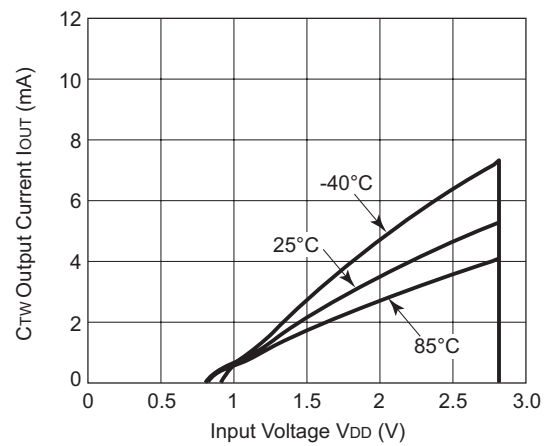

9) RESET Pin Output Current vs. Input Voltage
R5101G (VD=2.7V)

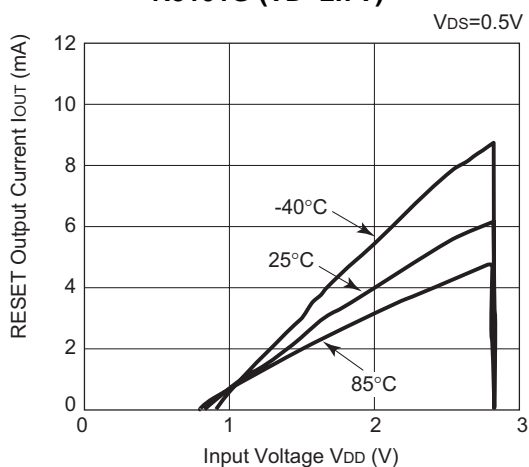

10) Delay Time of Released Voltage vs. Temperature
R5101G

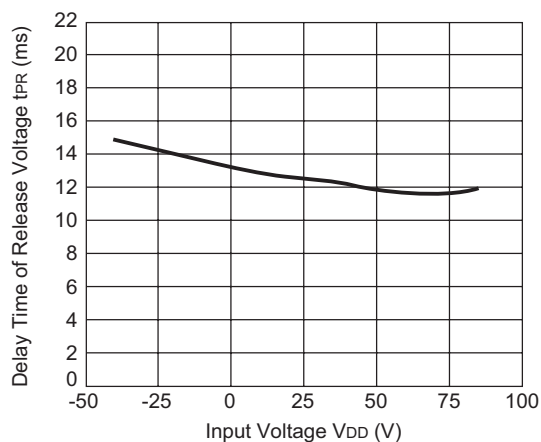

11) Watchdog Timeout period vs. Temperature
R5101G

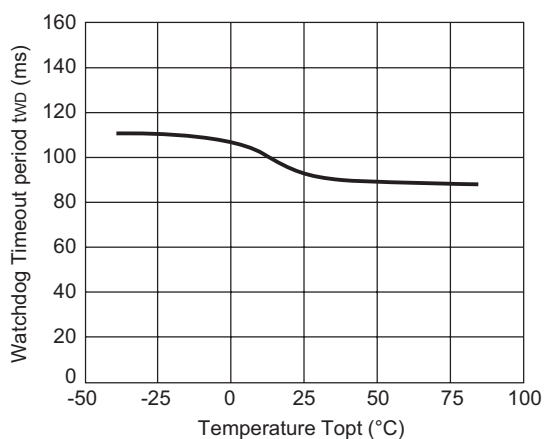

12) Reset Timeout period vs. Temperature
R5101G

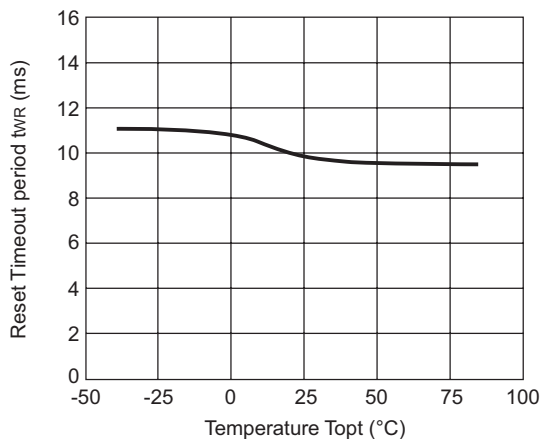

13) tPR vs. External Capacitance of C_D Pin

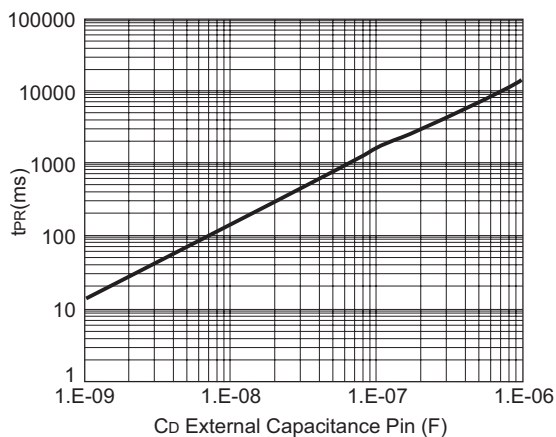

14) tWD, tWR vs. External Capacitance of C_{TW} Pin

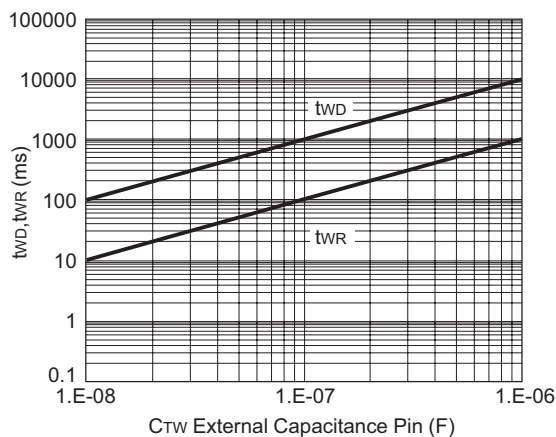

R5101G

15) CE Pull-up Resistance vs. Temperature

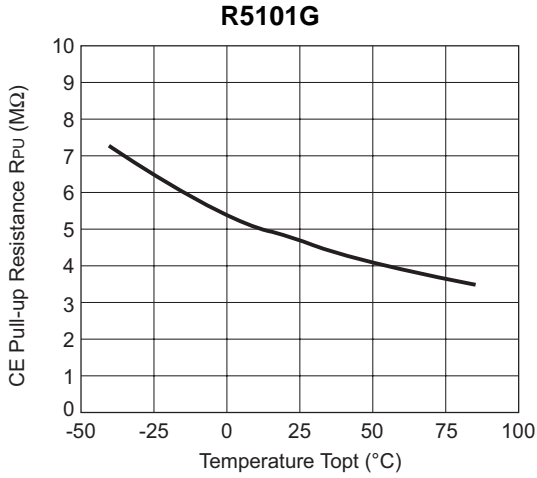

16) Supply Current vs. Input Voltage (WDT ON)

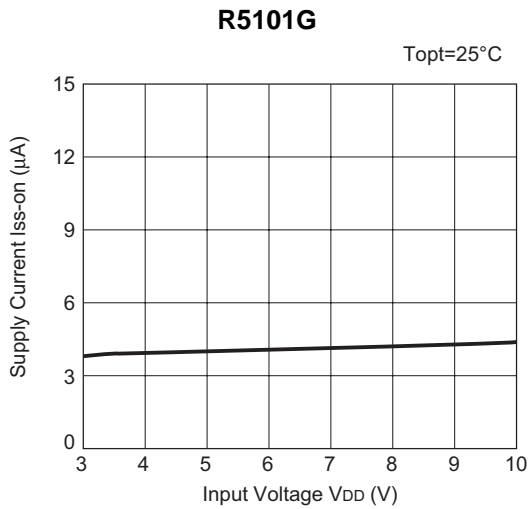

17) Supply Current vs. Temperature (WDT ON)

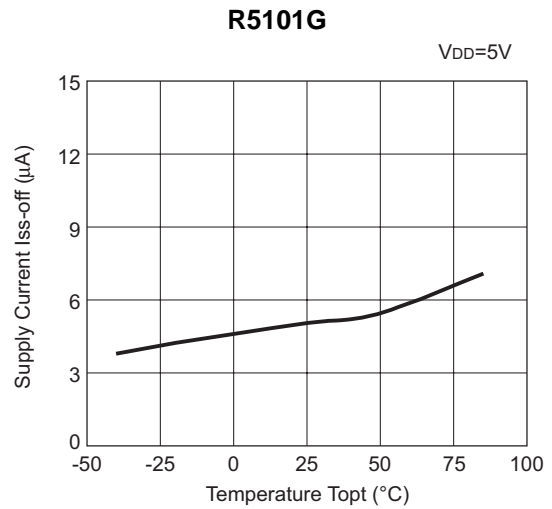

18) Supply Current vs. Input Voltage (WDT OFF)

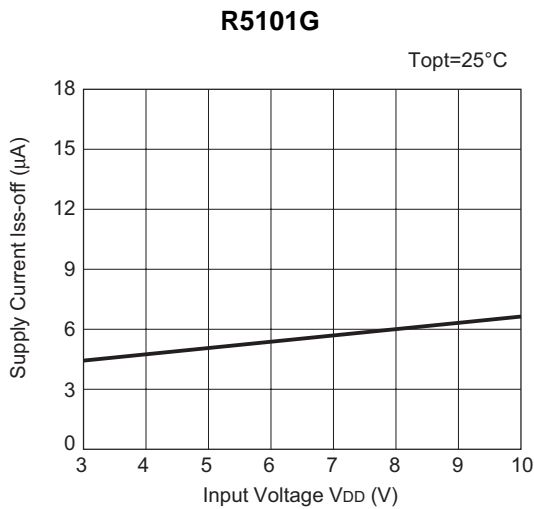

19) Supply Current vs. Temperature (WDT OFF)

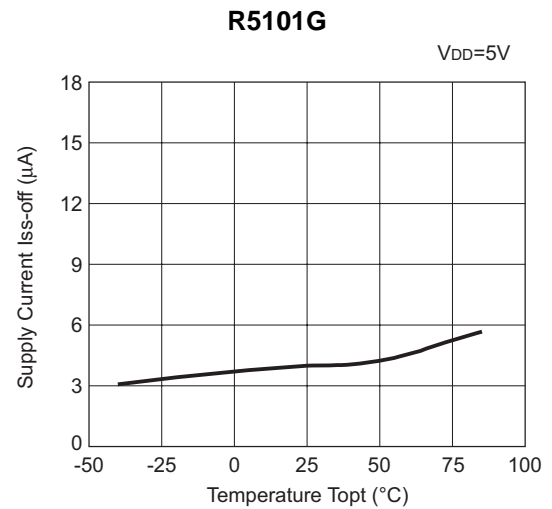



1. The products and the product specifications described in this document are subject to change or discontinuation of production without notice for reasons such as improvement. Therefore, before deciding to use the products, please refer to Ricoh sales representatives for the latest information thereon.
2. The materials in this document may not be copied or otherwise reproduced in whole or in part without prior written consent of Ricoh.
3. Please be sure to take any necessary formalities under relevant laws or regulations before exporting or otherwise taking out of your country the products or the technical information described herein.
4. The technical information described in this document shows typical characteristics of and example application circuits for the products. The release of such information is not to be construed as a warranty of or a grant of license under Ricoh's or any third party's intellectual property rights or any other rights.
5. The products listed in this document are intended and designed for use as general electronic components in standard applications (office equipment, telecommunication equipment, measuring instruments, consumer electronic products, amusement equipment etc.). Those customers intending to use a product in an application requiring extreme quality and reliability, for example, in a highly specific application where the failure or misoperation of the product could result in human injury or death (aircraft, spacevehicle, nuclear reactor control system, traffic control system, automotive and transportation equipment, combustion equipment, safety devices, life support system etc.) should first contact us.
6. We are making our continuous effort to improve the quality and reliability of our products, but semiconductor products are likely to fail with certain probability. In order to prevent any injury to persons or damages to property resulting from such failure, customers should be careful enough to incorporate safety measures in their design, such as redundancy feature, firecontainment feature and fail-safe feature. We do not assume any liability or responsibility for any loss or damage arising from misuse or inappropriate use of the products.
7. Anti-radiation design is not implemented in the products described in this document.
8. Please contact Ricoh sales representatives should you have any questions or comments concerning the products or the technical information.



For the conservation of the global environment, Ricoh is advancing the decrease of the negative environmental impact material.
After Apr. 1, 2006, we will ship out the lead free products only. Thus, all products that will be shipped from now on comply with RoHS Directive.
Basically after Apr. 1, 2012, we will ship out the Power Management ICs of the Halogen Free products only. (Ricoh Halogen Free products are also Antimony Free.)

RICOH RICOH COMPANY, LTD. Electronic Devices Company

<http://www.ricoh.com/LSI/>

RICOH COMPANY, LTD.

Electronic Devices Company

● Higashi-Shinagawa Office (International Sales)

3-32-3, Higashi-Shinagawa, Shinagawa-ku, Tokyo 140-8655, Japan
Phone: +81-3-5479-2857 Fax: +81-3-5479-0502

RICOH EUROPE (NETHERLANDS) B.V.

● Semiconductor Support Centre

"Nieuw Kronenburg" Prof. W.H. Keesomlaan 1, 1183 DJ, Amstelveen, The Netherlands
P.O.Box 114, 1180 AC Amstelveen
Phone: +31-20-5474-309 Fax: +31-20-5474-791

RICOH ELECTRONIC DEVICES KOREA Co., Ltd.

11 floor, Haesung 1 building, 942, Daechidong, Gangnamgu, Seoul, Korea
Phone: +82-2-2135-5700 Fax: +82-2-2135-5705

RICOH ELECTRONIC DEVICES SHANGHAI Co., Ltd.

Room403, No.2 Building, 690#Bi Bo Road, Pu Dong New district, Shanghai 201203,
People's Republic of China
Phone: +86-21-5027-3200 Fax: +86-21-5027-3299

RICOH COMPANY, LTD.

Electronic Devices Company

● Taipei office

Room109, 10F-1, No.51, Hengyang Rd., Taipei City, Taiwan (R.O.C.)
Phone: +886-2-2313-1621/1622 Fax: +886-2-2313-1623