

600mA* Step-down DC/DC Converter with Synchronous Rectifier

NO.EA-235-130509

OUTLINE

The RP503x Series are low supply current CMOS-based 600mA* step-down DC/DC Converters with synchronous rectifier. Each of these ICs consists of an oscillator, a switching control circuit, a reference voltage unit, an error amplifier, a soft-start circuit, UVLO circuit, a latch protection circuit, switching transistors, and so on. A low ripple, high efficiency step-down DC/DC converter can be easily composed of this IC with only an inductor and capacitors.

In terms of the output voltage, since the feedback resistances are built-in, the voltage is fixed internally. 0.1V step output can be set by laser-trim and 1.5% or 18mV tolerance depending on the output voltage is guaranteed. RP503x is PWM/VFM auto switching control in which mode automatically switches from PWM mode to high-efficiency VFM mode in low output current. The efficiency in low output current (VFM mode) improved compared with existing products.

As protection circuits, the current limit circuit which limits peak current of Lx at each clock cycle, and the latch type protection circuit which works if the term of the over-current condition keeps on a certain time exist. The latch-type protection circuit works to latch an internal driver with keeping it disable. To release the condition of the protection, after disabling this IC with a chip enable circuit, enable it again, or restart this IC with power-on or make the supply voltage at UVLO detector threshold level or lower than UVLO.

Since packages are WLCSP-6-P2 (Non-promotion), DFN1616-6, SOT-23-5, high density mounting on boards is possible.

*)This is an approximate value, because output current depends on conditions and external parts.

FEATURES

- Supply Current Typ. 20 μ A (at VFM mode, at no load)
- Standby Current Max. 5 μ A
- Input Voltage Range 2.5V to 5.5V (Absolute maximum rating; 6.5V)
- Output Voltage Range 0.8V to 2.5V (0.1V step)
- Output Voltage Accuracy $\pm 1.5\%$ ($V_{OUT} \geq 1.2V$), $\pm 18mV$ ($V_{OUT} < 1.2V$)
- Temperature-Drift Coefficient of Output Voltage ... Typ. $\pm 100ppm/^{\circ}C$
- Oscillator Frequency Typ. 2.0MHz
- Oscillator Maximum Duty Cycle Min. 100%
- Built-in Driver ON Resistance Typ. Pch. 0.34 Ω , Nch. 0.43 Ω ($V_{IN} = 3.6V$)
- UVLO Detector Threshold Typ. 2.2V
- Soft Start Time Typ. 0.15ms
- Lx Current Limit Typ. 800mA
- Latch type Protection Circuit Typ. 1.5ms
- Two choices of Switching Mode Automatic PWM/VFM mode change
- Packages DFN1616-6, WLCSP-6-P2 (Non-promotion), SOT-23-5

APPLICATIONS

- Power source for battery-powered equipment.
- Power source for hand-held communication equipment, cameras, VCRs, camcorders.
- Power source for HDD, portable equipment.

BLOCK DIAGRAMS

RP503Zxx1A (Non-promotion)
RP503Lxx1A

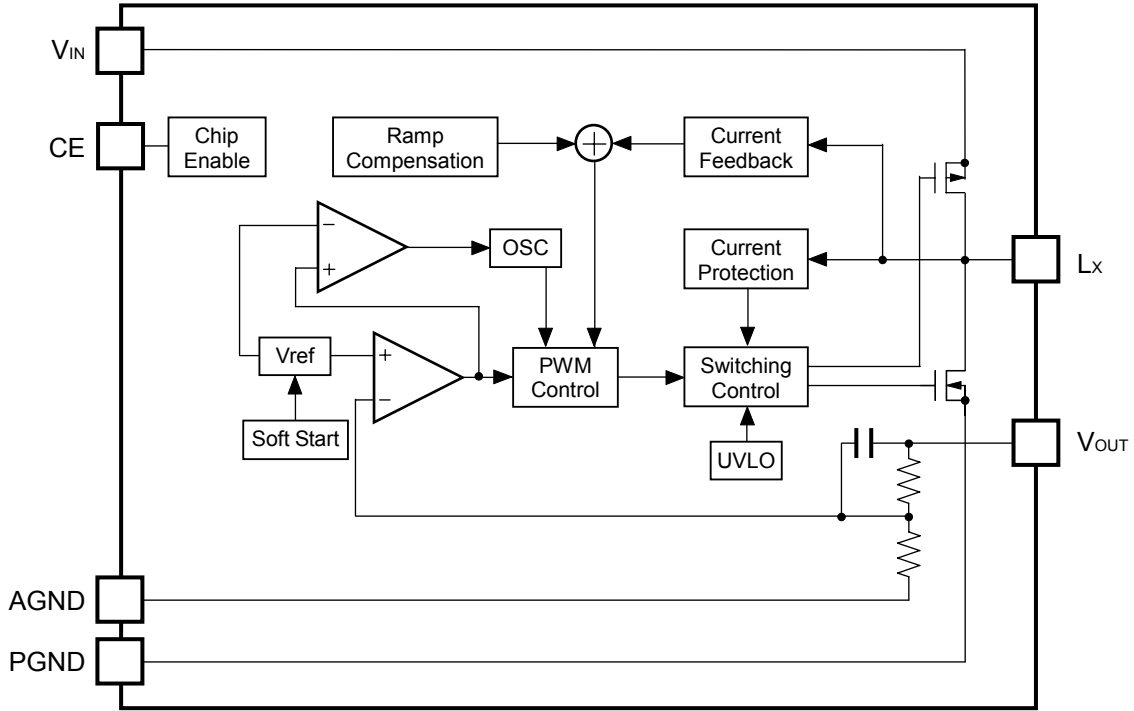

RP503Zxx2A (Non-promoiton)
RP503Lxx2A

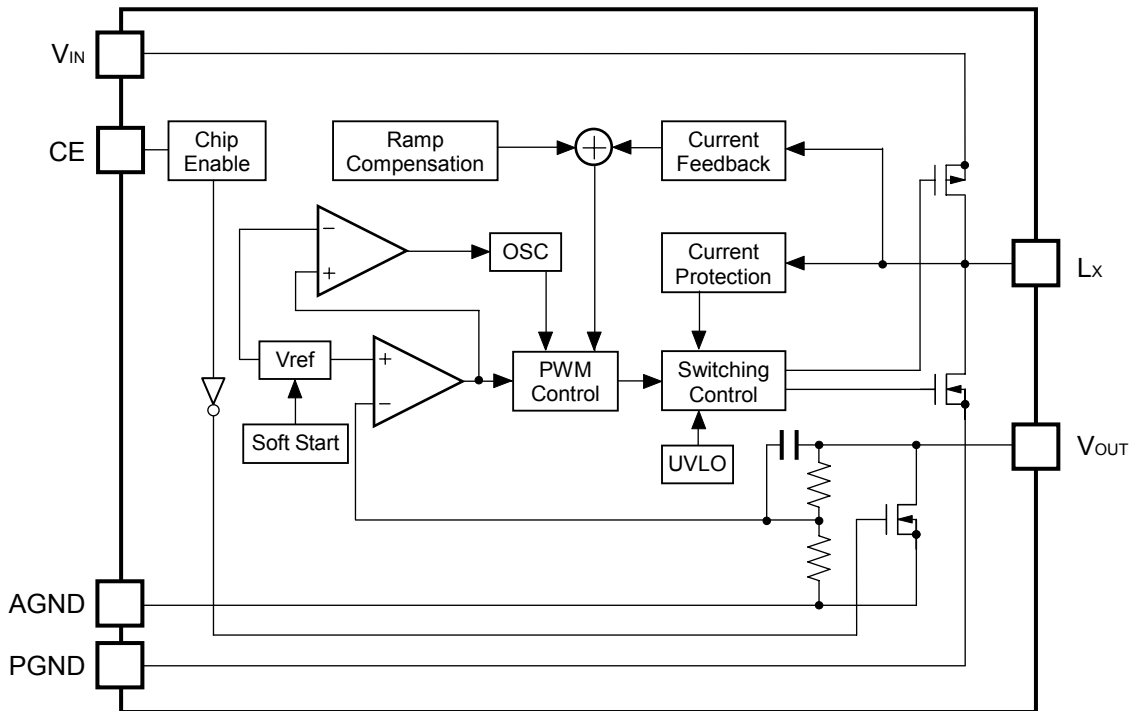

RP503Nxx1A

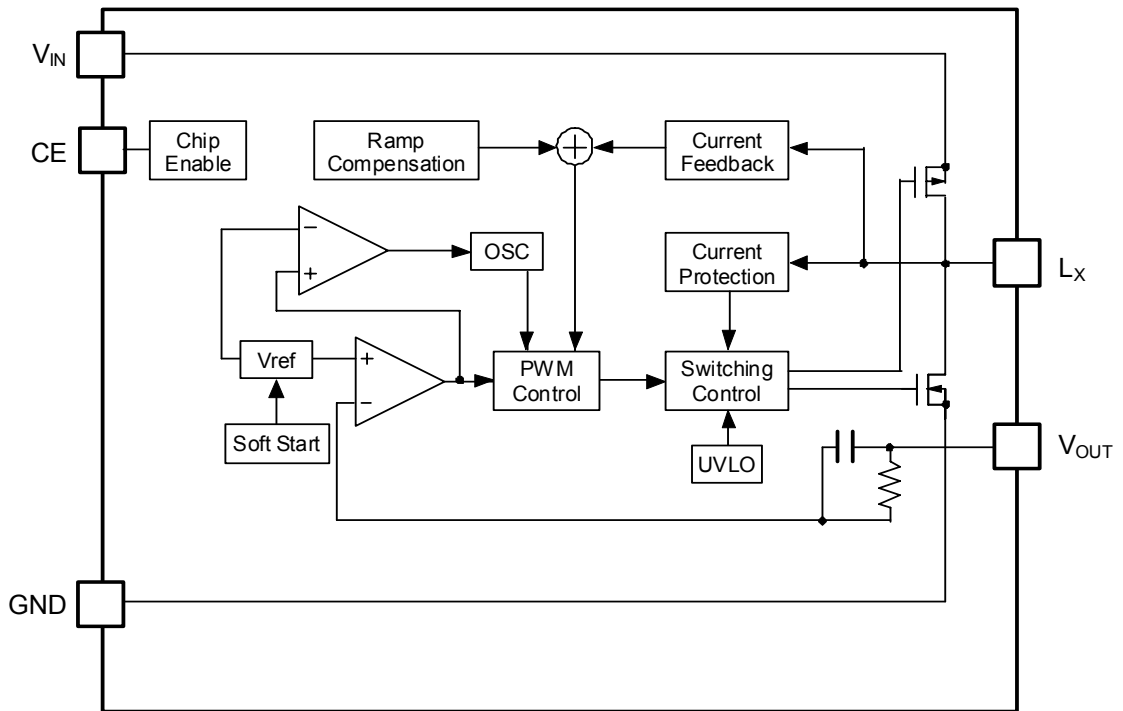

RP503Nxx2A

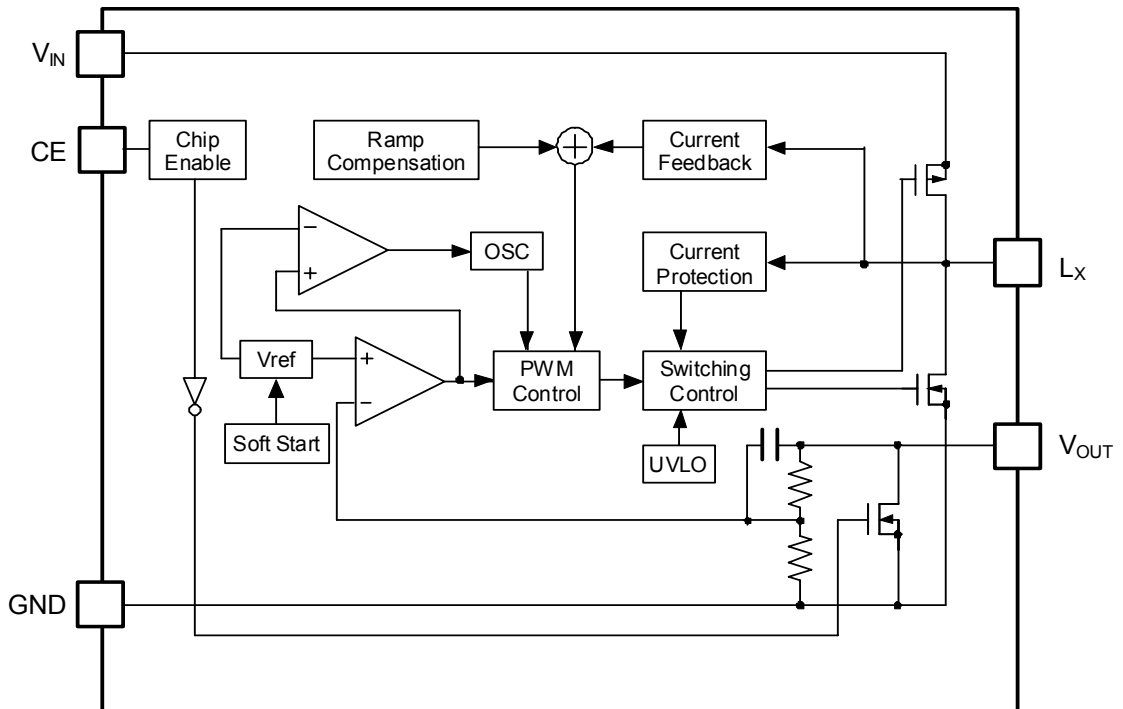

SELECTION GUIDE

The output voltage, auto discharge function, and package for the ICs can be selected at the user's request.

Product Name	Package	Quantity per Reel	Pb Free	Halogen Free
RP503Zxx*A-E2-F	WLCSP-6-P2 (Non-promotion)	5,000 pcs	Yes	Yes
RP503Lxx*A-TR	DFN1616-6	5,000 pcs	Yes	Yes
RP503Nxx*A-TR-FE	SOT-23-5	3,000 pcs	Yes	Yes

xx: The output voltage can be designated in the range from 0.8V(08) to 2.5V(25) in 0.1V steps*.
(For other voltages, please refer to MARK INFORMATIONS.)

* : The auto discharge function at off state are options as follows.
(1) without auto discharge function at off state
(2) with auto discharge function at off state

*) 0.05V step is also available as a custom code.

The products scheduled to be discontinued (be sold to limited customer) : "Limited"

These products will be discontinued in the future. You can not select these products newly.
We will provide these products to the customer who has been using or has ordered them before.
But we recommend changing to other products as soon as possible.

PIN CONFIGURATIONS

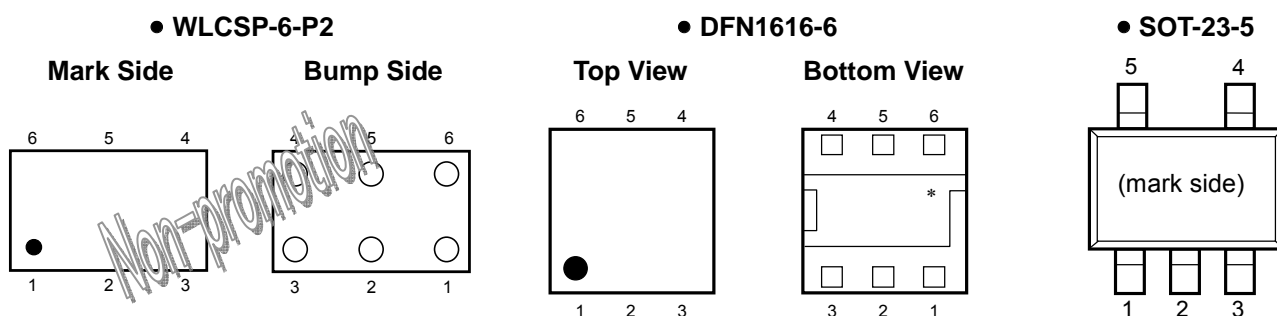

PIN DESCRIPTIONS

• WLCSP-6-P2 (Non-promotion)

Pin No	Symbol	Pin Description
1	V_{OUT}	Output Pin
2	PGND	Ground Pin
3	Lx	Lx Switching Pin
4	V_{IN}	Input Pin
5	AGND	Ground Pin
6	CE	Chip Enable Pin ("H" Active)

• DFN1616-6

Pin No	Symbol	Pin Description
1	CE	Chip Enable Pin ("H" Active)
2	AGND	Ground Pin
3	V_{IN}	Input Pin
4	Lx	Lx Switching Pin
5	PGND	Ground Pin
6	V_{OUT}	Output Pin

*) Tab is GND level. (They are connected to the reverse side of this IC.)

The tab is better to be connected to the GND, but leaving it open is also acceptable.

• SOT-23-5

Pin No	Symbol	Pin Description
1	V_{OUT}	Output Pin
2	GND	Ground Pin
3	Lx	Lx Switching Pin
4	V_{IN}	Input Pin
5	CE	Chip Enable Pin ("H" Active)

ABSOLUTE MAXIMUM RATINGS

AGND=PGND=0V

Symbol	Item	Rating	Unit
V_{IN}	Input Voltage	-0.3 to 6.5	V
V_{Lx}	Lx pin Voltage	-0.3 to $V_{IN}+0.3$	V
V_{CE}	CE Pin Input Voltage	-0.3 to 6.5	V
V_{OUT}	Output Voltage	-0.3 to 6.5	V
I_{Lx}	Lx Pin Output Current	800	mA
P_D	Power Dissipation (WLCSP-6-P2) (Non-promotion) *	650	mW
	Power Dissipation (DFN1616-6) *	640	
	Power Dissipation (SOT-23-5) *	420	
T_{opt}	Operating Temperature Range	-40 to 85	°C
T_{stg}	Storage Temperature Range	-55 to 125	°C

*) For Power Dissipation, please refer to PACKAGE INFORMATION.

ABSOLUTE MAXIMUM RATINGS

Electronic and mechanical stress momentarily exceeded absolute maximum ratings may cause the permanent damages and may degrade the life time and safety for both device and system using the device in the field. The functional operation at or over these absolute maximum ratings is not assured.

ELECTRICAL CHARACTERISTICS

• RP503x

T_{opt}=25°C

Symbol	Item	Conditions	Min.	Typ.	Max.	Unit
V _{IN}	Operating Input Voltage		2.5		5.5	V
V _{OUT}	Output Voltage	V _{IN} =V _{CE} =3.6V	V _{OUT} ≥ 1.2V	×0.985	×1.015	V
			V _{OUT} < 1.2V	-18	18	mV
ΔV _{OUT} /ΔT _{opt}	Output Voltage Temperature Coefficient	-40°C ≤ T _{opt} ≤ 85°C		±100		ppm /°C
f _{osc}	Oscillator Frequency	V _{IN} =V _{CE} =V _{OUT} +1.7V	1.7	2.0	2.3	MHz
I _{DD}	Supply Current	V _{IN} =V _{CE} =5.5V, V _{OUT} =5.5V		20	32	μA
I _{standby}	Standby Current	V _{IN} =5.5V, V _{CE} =0V		0	5	μA
R _{ONP}	ON Resistance of Pch Tr.	V _{IN} =3.6V, I _{LX} =-100mA		0.34		Ω
R _{ONN}	ON Resistance of Nch Tr.	V _{IN} =3.6V, I _{LX} =-100mA		0.43		Ω
I _{LXleakH}	Lx Leakage Current "H"	V _{IN} =V _{LX} =5.5V, V _{CE} =0V	-1	0	5	μA
I _{LXleakL}	Lx Leakage Current "L"	V _{IN} =5.5V, V _{CE} =V _{LX} =0V	-5	0	1	μA
I _{VOUTH}	V _{OUT} "H" Input Current	V _{IN} =V _{OUT} =5.5V, V _{CE} =0V	-1	0	1	μA
I _{VOUTL}	V _{OUT} "L" Input Current	V _{IN} =5.5V, V _{CE} =V _{OUT} =0V	-1	0	1	μA
I _{CEH}	CE "H" Input Current	V _{IN} =V _{CE} =5.5V	-1	0	1	μA
I _{CEL}	CE "L" Input Current	V _{IN} =5.5V, V _{CE} =0V	-1	0	1	μA
V _{CEH}	CE Input Voltage "H"	V _{IN} =5.5V	1.0			V
V _{CEL}	CE Input Voltage "L"	V _{IN} =2.5V			0.4	V
Maxduty	Oscillator Maximum Duty Cycle		100			%
t _{start}	Soft-start Time*	V _{IN} =V _{CE} =3.6V		150	300	μs
I _{LXlim}	Lx Current Limit	V _{IN} =V _{CE} =3.6V	600	800		mA
t _{prot}	Protection Delay Time	V _{IN} =V _{CE} =3.6V	0.5	1.5	5.0	ms
V _{UVLO1}	UVLO Detector Threshold	V _{IN} =V _{CE}	2.1	2.2	2.3	V
V _{UVLO2}	UVLO Released Voltage	V _{IN} =V _{CE}	2.2	2.3	2.4	V
R _{LOW}	Low Output Nch Tr. ON Resistance (RP503xxx2A only)	V _{IN} =3.6V, V _{CE} =0V		30		Ω

Test circuit is "OPEN LOOP" and AGND=PGND=0V unless otherwise noted.

*) The time until the 90% voltage of setting voltage.

RECOMMENDED OPERATING CONDITIONS (ELECTRICAL CHARACTERISTICS)

All of electronic equipment should be designed that the mounted semiconductor devices operate within the recommended operating conditions. The semiconductor devices cannot operate normally over the recommended operating conditions, even if when they are used over such conditions by momentary electronic noise or surge. And the semiconductor devices may receive serious damage when they continue to operate over the recommended operating conditions.

TEST CIRCUITS

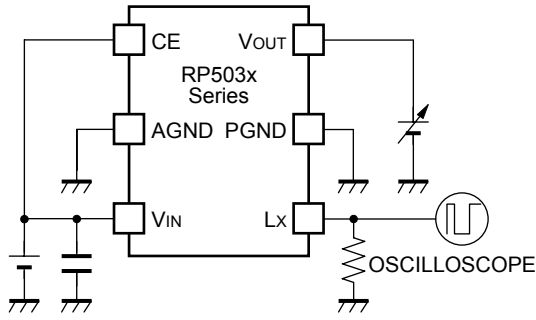

Output Voltage

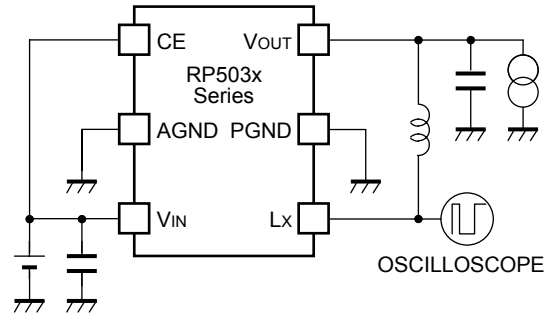

Oscillator Frequency

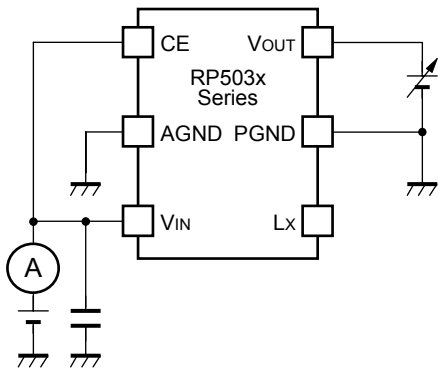

Supply Current 1,2

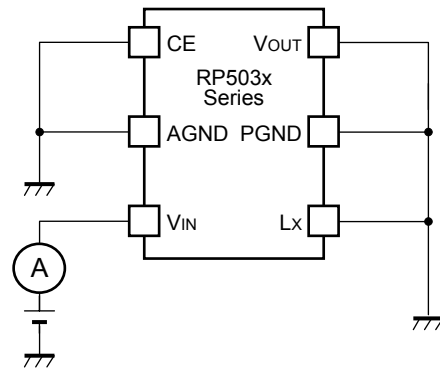

Standby Current

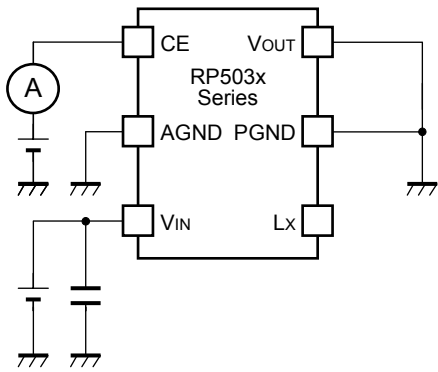

CE "H"/"L" Input Current

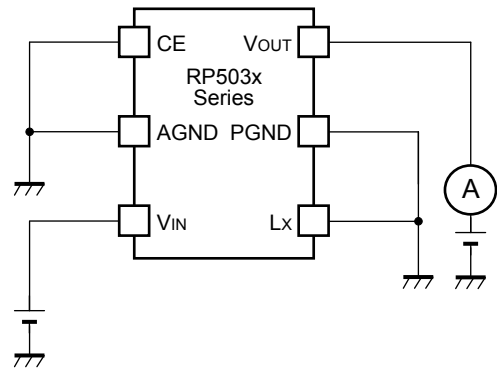

V_{OUT} "H"/"L" Current

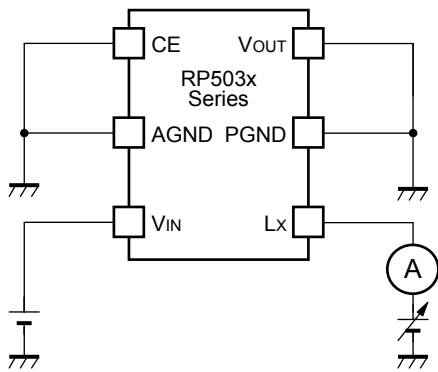

Lx Leakage Current

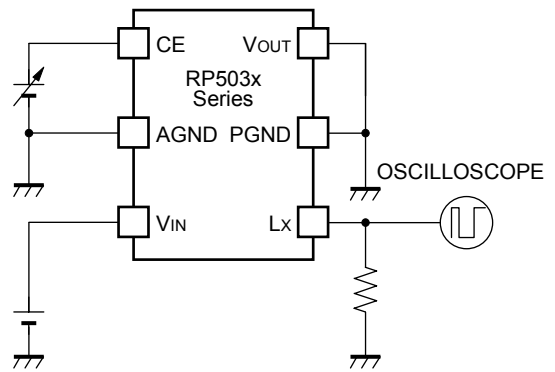

CE Input Voltage

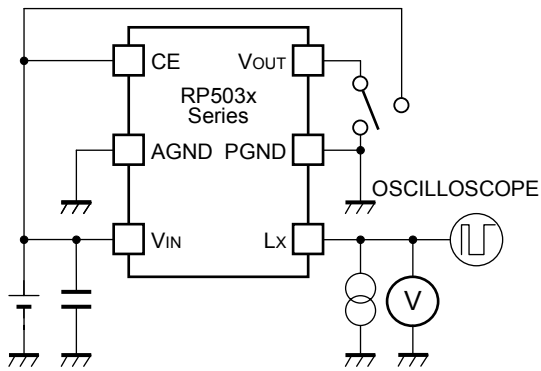

**Pch • Nch transistor ON resistance /
Output Delay for Protection / Lx Current limit**

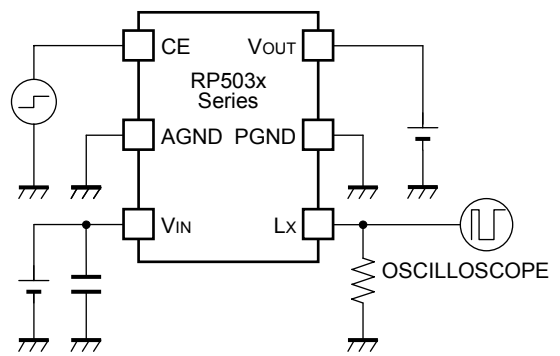

Soft-start Time

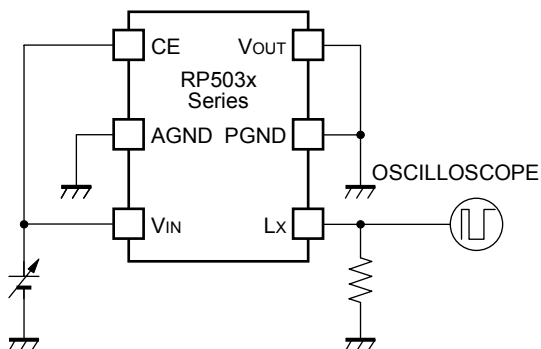

UVLO Detector Threshold • Released Voltage

TYPICAL APPLICATION

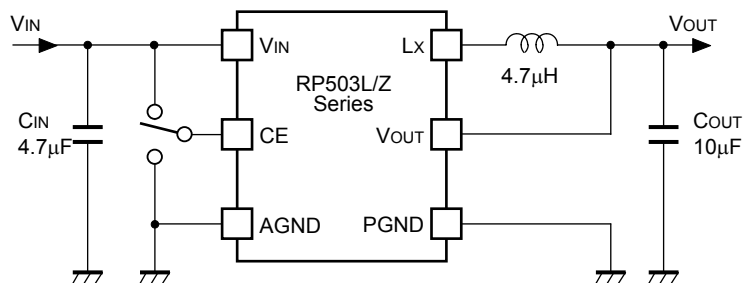

RP503L/ZxxxA

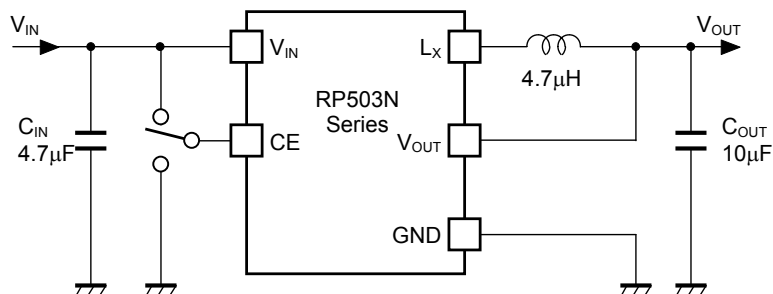

RP503NxxxA

Symbol	Parts Recommendation		
C _{IN}	4.7µF	Ceramic	C1608JB0J475K (TDK)
C _{OUT}	10µF	Ceramic	C1608JB0J106M (TDK)
L	4.7µH	SMD inductor	NR 3010T 4R7M (TAIYO YUDEN)

- If V_{IN} is in the range of 3.0V to 4.5V and V_{OUT} is 1.2V, the following small-sized components can be used.

Symbol			
L	2.2µH	SMD inductor	CPL2510T2R2M (TDK)
	4.7µH	SMD inductor	BRFL2518T4R7M (TAIYO YUDEN)
	2.2µH	Multilayer chip inductor	MIPS2520D2R2 (FDK)
C _{IN}	2.2µF×2	Ceramic	GRM155B30J225M (Murata)

- If V_{IN} is in the range of 3.0V to 4.5V, V_{OUT} is 1.2V, and I_{OUT} is lower than 500mA, the following small and low-profile components can be used.

Symbol			
C _{IN}	4.7µF	Ceramic	GRM185B30J475ME15 (Murata)
C _{OUT}	10µF	Ceramic	GRM155R60G106ME44 (Murata)
L	2.2µH	SMD inductor	CPL2006T2R2M (TDK)

TECHNICAL NOTES

When using these ICs, consider the following points:

- Set the same level as AGND and PGND.
 - Set external components such as an inductor, C_{IN} , C_{OUT} as close as possible to the IC, in particular, minimize the wiring to V_{IN} pin and PGND pin. Reinforce the V_{IN} , PGND, and V_{OUT} lines sufficiently. Large switching current may flow in these lines. If the impedance of V_{IN} and PGND lines is too large, the internal voltage level in this IC may shift caused by the switching current, and the operation might be unstable. The wiring between V_{OUT} and load and between L and V_{OUT} should be separated.
 - Use external ceramic capacitors with good frequency characteristics and ESR. C_{IN} between V_{IN} and GND with a capacity of $4.7\mu\text{F}$ or more and C_{OUT} with a capacity of $10\mu\text{F}$ or more are recommended.
 - Choose an inductor with inductance range from $2.2\mu\text{H}$ to $4.7\mu\text{H}$. The phase compensation has been made by these values with output capacitors. The recommendation characteristics of the inductor are low DC resistance, large enough permissible current, and strong against the magnetic saturation. Inductance value may shift depending on an inductor. If the inductance value at an actual load current is low, L_x peak current may increase and may overlap the L_x current limit. As a result, over current protection may work.
 - Over current protection circuit may be affected by self-heating and heat radiation environment.
- *The performance of power source circuits using these ICs extremely depends upon the peripheral circuits. Pay attention in the selection of the peripheral circuits. In particular, design the peripheral circuits in a way that the values such as voltage, current, and power of each component, PCB patterns and the IC do not exceed their respected rated values. (such as the voltage, current, and power)

Operation of step-down DC/DC converter and Output Current

The DC/DC converter charges energy in the inductor when Lx transistor is ON, and discharges the energy from the inductor when Lx transistor is OFF and controls with less energy loss, so that a lower output voltage than the input voltage is obtained. The operation will be explained with reference to the following diagrams:

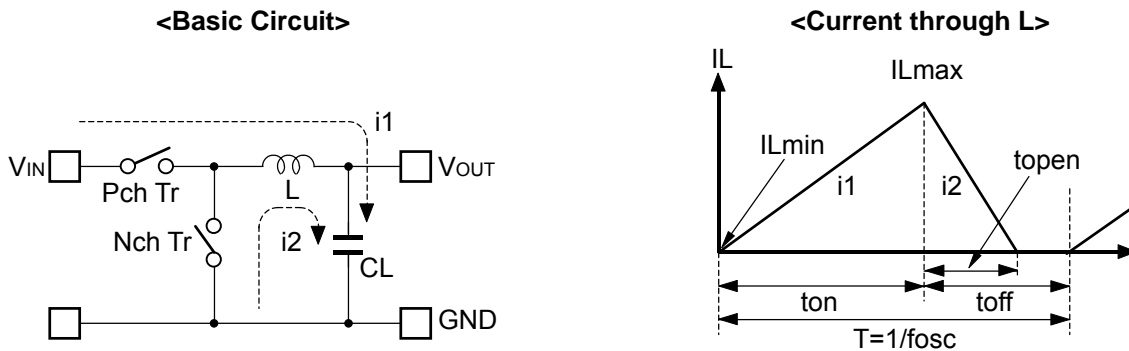

- Step 1: Pch Tr. turns on and current $I_L (=i_1)$ flows, and energy is charged into CL. At this moment, I_L increases from $I_{Lmin} (=0)$ to reach I_{Lmax} in proportion to the on-time period (t_{on}) of Pch Tr.
- Step 2: When Pch Tr. turns off, Synchronous rectifier Nch Tr. turns on in order that L maintains I_L at I_{Lmax} , and current $I_L (=i_2)$ flows.
- Step 3: $I_L (=i_2)$ decreases gradually and reaches $I_L = I_{Lmin} = 0$ after a time period of t_{open} , and Nch Tr. turns off. Provided that in the continuous mode, next cycle starts before I_L becomes to 0 because t_{off} time is not enough. In this case, I_L value increases from this $I_{Lmin} (>0)$.

In the case of PWM control system, the output voltage is maintained by controlling the on-time period (t_{on}), with the oscillator frequency (f_{osc}) being maintained constant.

The maximum value (I_{Lmax}) and the minimum value (I_{Lmin}) of the current flowing through the inductor are the same as those when Pch Tr. turns on and off.

The difference between I_{Lmax} and I_{Lmin} , which is represented by ΔI :

$$\Delta I = I_{Lmax} - I_{Lmin} = V_{OUT} \times t_{open} / L = (V_{IN} - V_{OUT}) \times t_{on} / L \dots\dots\dots \text{Equation 1}$$

wherein,

$$T = 1 / f_{osc} = t_{on} + t_{off}$$

$$\text{duty (\%)} = t_{on} / T \times 100 = t_{on} \times f_{osc} \times 100$$

$$t_{open} \leq t_{off}$$

In Equation 1, $V_{OUT} \times t_{open} / L$ and $(V_{IN} - V_{OUT}) \times t_{on} / L$ respectively show the change of the current at "ON", and the change of the current at "OFF".

Discontinuous mode and Continuous mode

When the output current (I_{OUT}) is relatively small, $t_{open} < t_{off}$ as illustrated in the above diagram. In this case, the energy is charged in the inductor during the time period of t_{on} and is discharged in its entirety during the time period of t_{off} , therefore I_{Lmin} becomes to zero ($I_{Lmin}=0$). When I_{OUT} is gradually increased, eventually, t_{open} becomes to t_{off} ($t_{open}=t_{off}$), and when I_{OUT} is further increased, I_{Lmin} becomes larger than zero ($I_{Lmin}>0$). The former mode is referred to as the discontinuous mode and the latter mode is referred to as continuous mode.

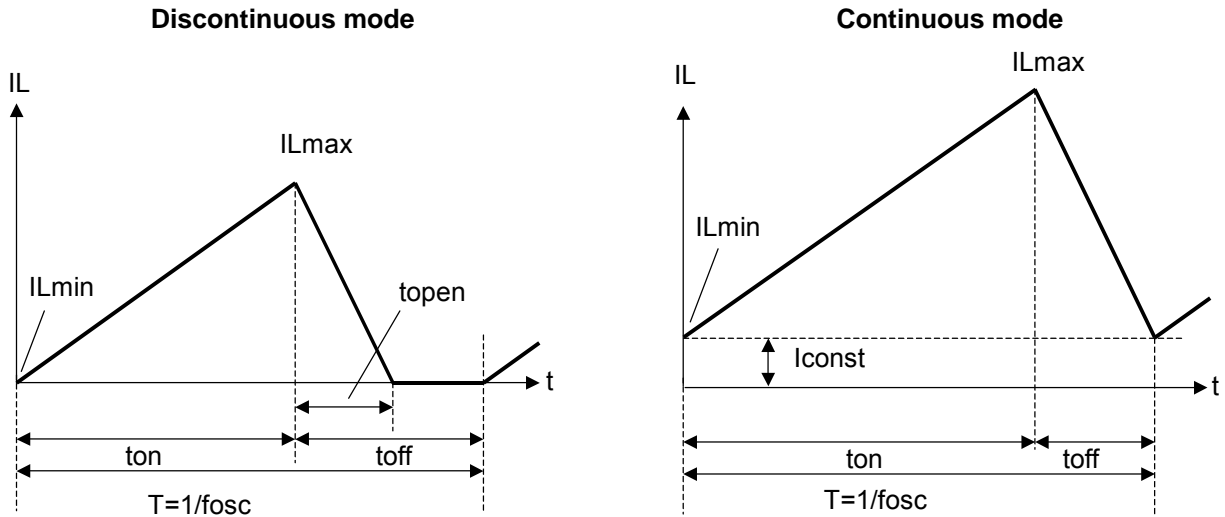

In the continuous mode, when Equation 1 is solved for t_{on} and assumed that the solution is t_{onc} ,

$$t_{onc} = T \times V_{OUT} / V_{IN} \dots \dots \dots \text{Equation 2}$$

When $t_{on} < t_{onc}$, the mode is the discontinuous mode, and when $t_{on} = t_{onc}$, the mode is the continuous mode.

Output Current and selection of External components

The relation between the output current and external components is as follows:

(Wherein, Ripple Current p-p value is described as I_{RP} , ON resistance of Pch Tr. and Nch Tr. of LX are respectively described as R_{ONP} and R_{ONN} , and the DC resistor of the inductor is described as R_L .)

When Pch Tr. of LX is ON:

$$V_{IN} = V_{OUT} + (R_{ONP} + R_L) \times I_{OUT} + L \times I_{RP} / t_{on} \dots\dots\dots \text{Equation 3}$$

When Pch Tr. of LX is "OFF" (Nch Tr. is "ON"):

$$L \times I_{RP} / t_{off} = R_{ONN} \times I_{OUT} + V_{OUT} + R_L \times I_{OUT} \dots\dots\dots \text{Equation 4}$$

Put Equation 4 to Equation 3 and solve for ON duty of Pch transistor, $D_{ON} = t_{on} / (t_{off} + t_{on})$,

$$D_{ON} = (V_{OUT} + R_{ONN} \times I_{OUT} + R_L \times I_{OUT}) / (V_{IN} + R_{ONN} \times I_{OUT} - R_{ONP} \times I_{OUT}) \dots\dots\dots \text{Equation 5}$$

Ripple Current is as follows:

$$I_{RP} = (V_{IN} - V_{OUT} - R_{ONP} \times I_{OUT} - R_L \times I_{OUT}) \times D_{ON} / f_{osc} / L \dots\dots\dots \text{Equation 6}$$

wherein, peak current that flows through L, and LX Tr. is as follows:

$$I_{LXmax} = I_{OUT} + I_{RP} / 2 \dots\dots\dots \text{Equation 7}$$

*Consider I_{LXmax} , condition of input and output and select external components.

*The above explanation is directed to the calculation in an ideal case in continuous mode.

TIMING CHART

(1) Soft Start Time

- In the case of starting this IC with CE

In the case of starting this IC with CE, the operation can be as in the timing chart below.

When the voltage of CE pin (V_{CE}) is beyond the threshold level, the operation of the IC starts. The threshold voltage of CE pin is in between CE "H" input voltage (V_{CEH}) and CE "L" input voltage (V_{CEL}) described in the electrical characteristics table. Soft-start circuit operates, and after the certain time, the reference voltage inside the IC (V_{REF}) is rising gradually up to the constant value.

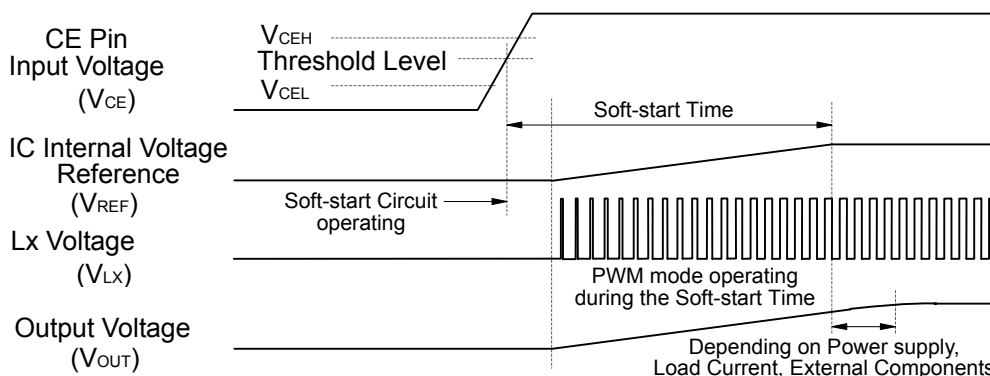

Soft-start time is the time interval from soft start circuit starting point to the reference voltage level reaching point up to this constant level.

*Soft start time is not always equal to the turn-on speed of DC/DC converter.

The power supply capacity for this IC, load current, inductance and capacitance values affect the turn-on speed.

- In the case of starting with power supply

In the case of starting with power supply, when the input voltage (V_{IN}) is larger than UVLO released voltage (V_{UVLO2}), soft start circuit operates, and after that, the same explanation above is applied to the operation.

Soft-start time is the time interval from soft start circuit starting point to the reference voltage level reaching point up to this constant level.

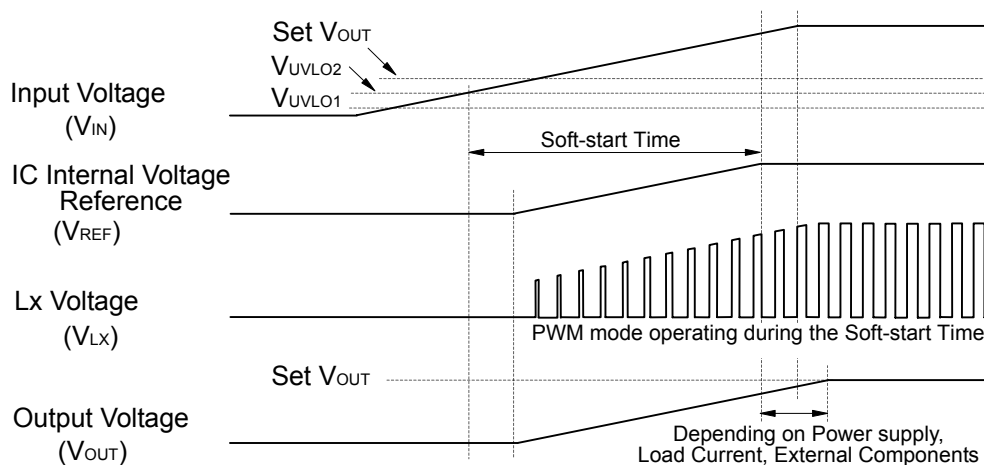

*Turn-on speed is affected by next conditions;

(a) Input Voltage (V_{IN}) rising speed depending on the power supplier to the IC and input capacitor C_{IN} .

(b) Output Capacitor C_{OUT} value and load current value.

(2) Under Voltage Lockout (UVLO) Circuit

The step-down DC/DC converter stops and ON duty becomes 100%, if input voltage (V_{IN}) becomes less than the set output voltage (Set V_{OUT}), the output voltage (V_{OUT}) gradually drops according to the input voltage (V_{IN}). If the input voltage drops more and becomes less than UVLO detector threshold (V_{UVLO1}), the under voltage lockout circuit (UVLO) operates, the IC internal reference voltage (V_{REF}) stops, switching transistors turn off and the output voltage drops according to the load and output capacitor C_{OUT} value. To restart the normal operation, the input voltage (V_{IN}) must be more than the UVLO released voltage (V_{UVLO2}).

The timing chart below describes the operation with varying the input voltage (V_{IN}).

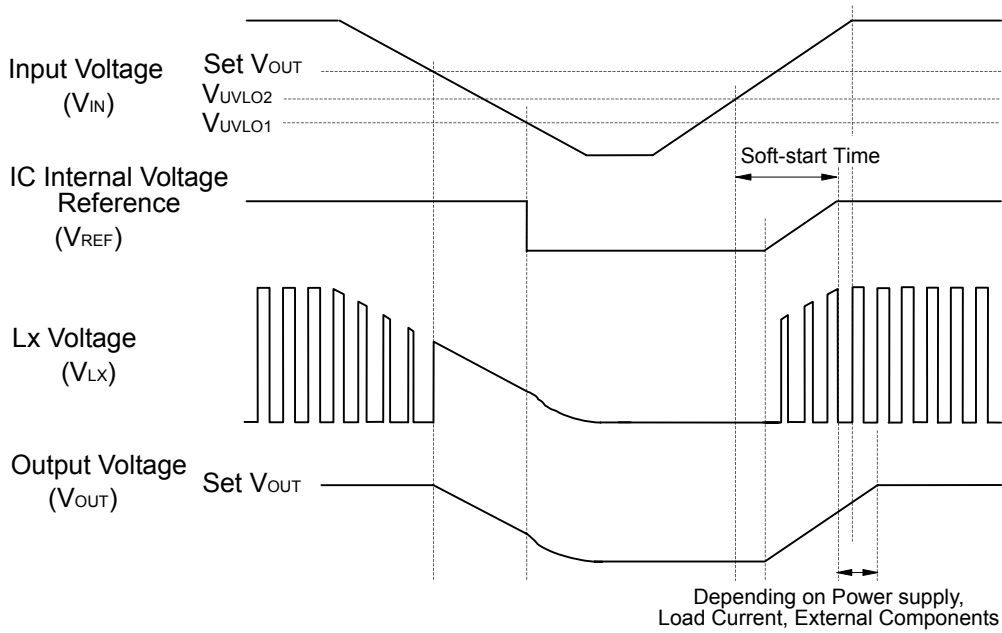

*Actually, the waveform of V_{OUT} at UVLO working and releasing varies depending on the initial voltage of C_{OUT} and load current situation.

(3) Over Current Protection Circuit, Latch Type Protection Circuit

Over current protection circuit supervises the coil peak current (the current flowing Pch transistor) at each switching cycle, and if the current beyond the Lx current limit (I_{Lxlim}), Pch transistor is turned off. the Lx current limit of RP503x is Typ.800mA.

Further, if the over current status continues equal or longer than protection delay time, a built-in driver is latched in the OFF state and the operation of DC/DC converter stops.

*Lx current limit (I_{Lxlim}) and protection delay time (t_{prot}) is affected by self-heating and ambient environment. If the output is short and the input voltage (V_{IN}) is drastically dropped or becomes unstable, the protection operation and delay time may vary.

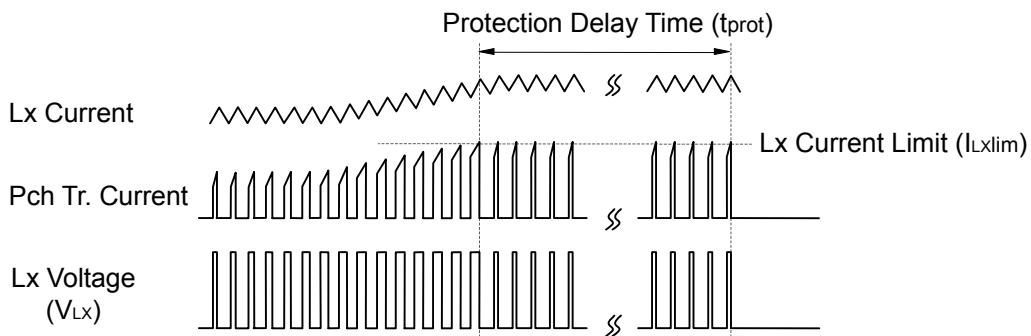

To release the condition of latch type protection, restart this IC by inputting "L" signal to CE pin, or restart this IC with power-on or make the supply voltage lower than UVLO detector threshold (V_{UVLO1}) level.

The timing chart shown below describes the changing process of input voltage rising, stable operating, operating with large current, reset with CE pin, stable operating, input voltage falling, input voltage recovering, and stable operating.

If too large current flows through the circuit because of short or other reasons, after the delay time of latch type protection a built-in driver is latched in the OFF state and V_{Lx} signal will be "L", then output will turn off. At the point (1), release the latch type protection is realized with CE reset as changed CE signal from "L" to "H".

At the point (2), release the latch type protection is realized with UVLO reset as make the supply voltage lower than UVLO detector threshold (V_{UVLO1}) level.

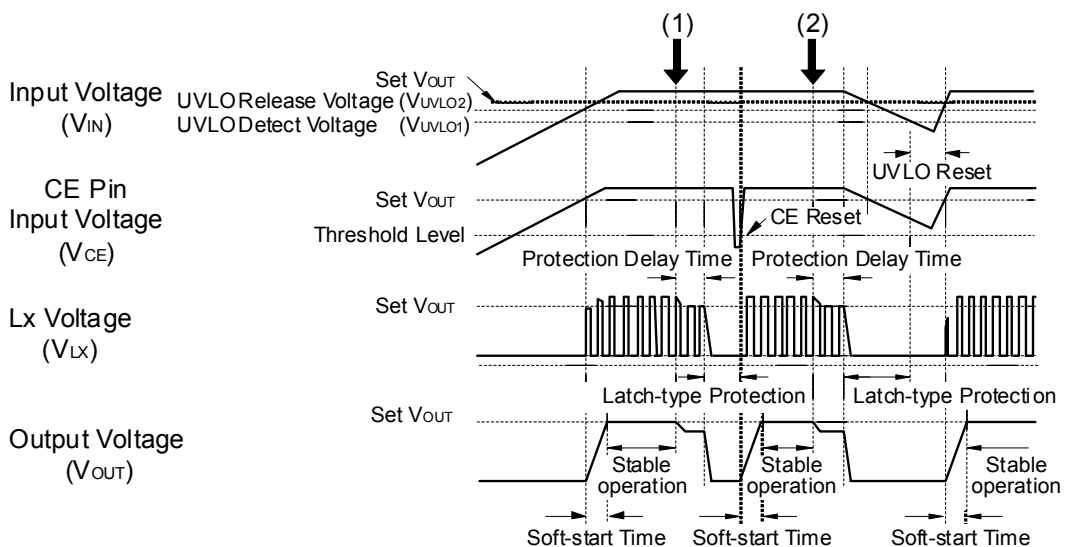

TYPICAL CHARACTERISTICS*

1) Output Voltage vs. Output Current

RP503x08xA (VFM MODE)

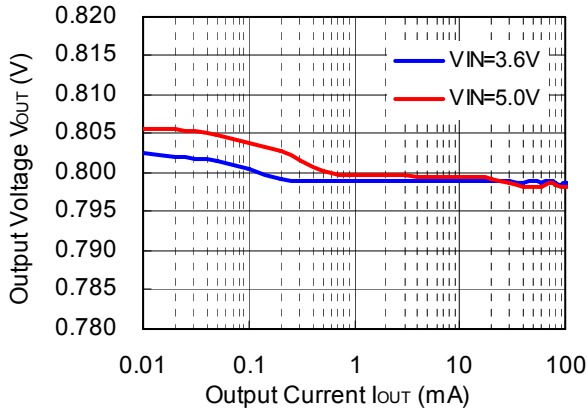

RP503x08xA (PWM MODE)

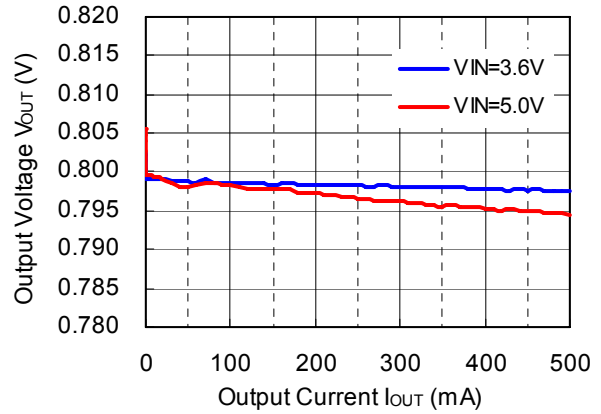

RP503x12xA (VFM MODE)

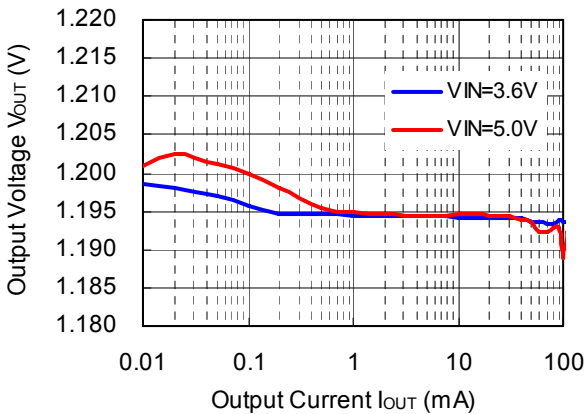

RP503x12xA (PWM MODE)

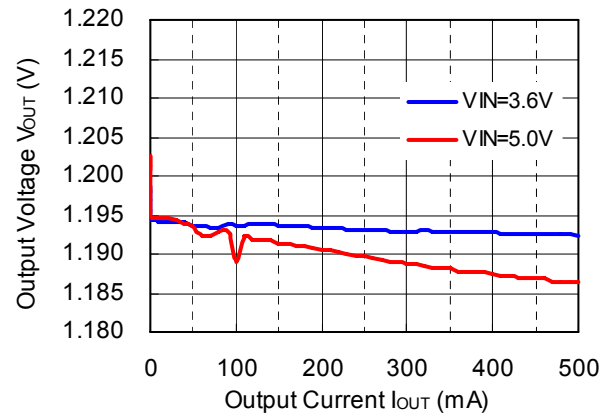

RP503x18xA (VFM MODE)

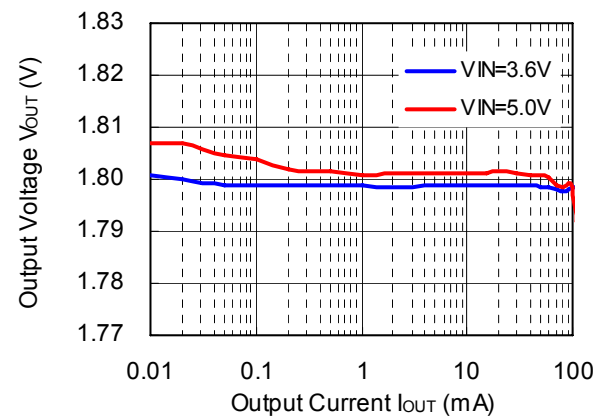

RP503x18xA (PWM MODE)

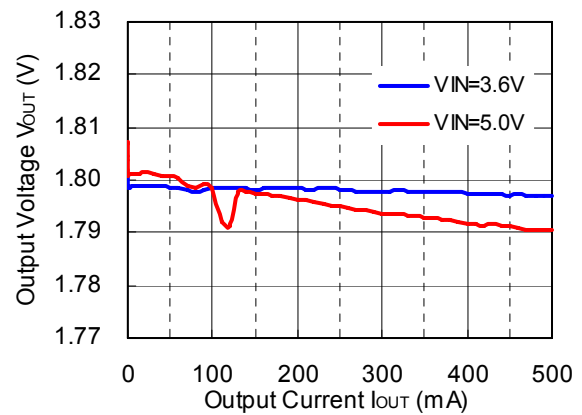

RP503x25xA (VFM MODE)

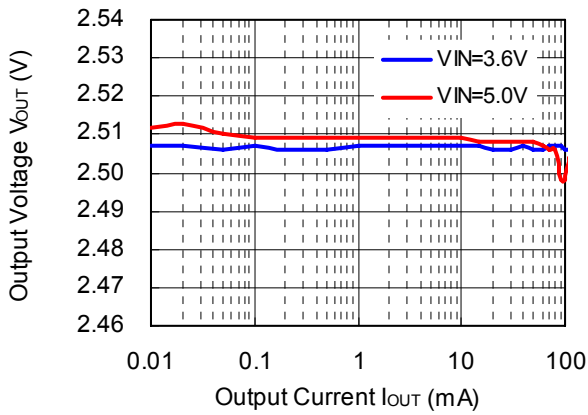

RP503x25xA (PWM MODE)

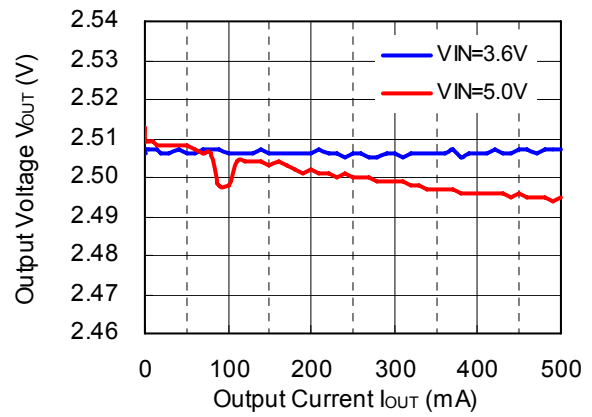

2) Output Voltage vs. Input Voltage

RP503x08xA

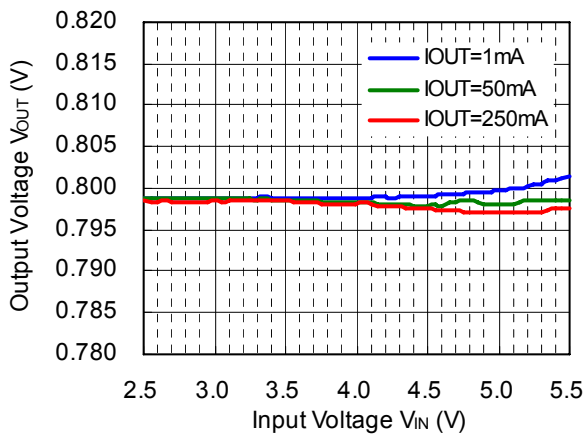

RP503x12xA

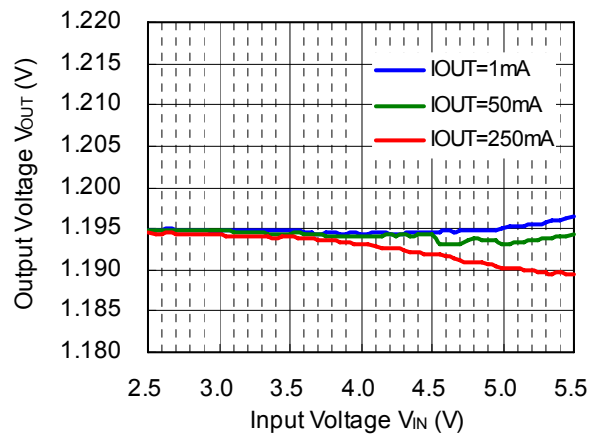

RP503x18xA

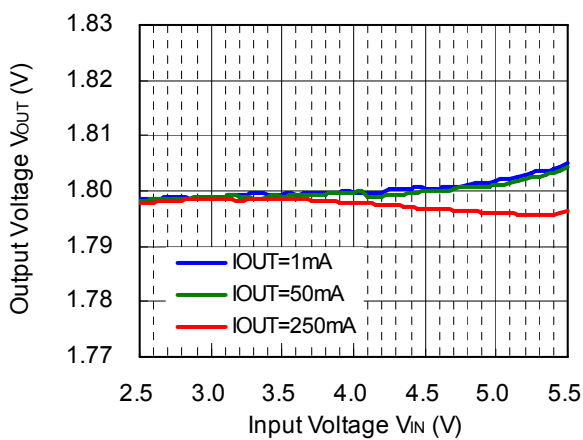

RP503x25xA

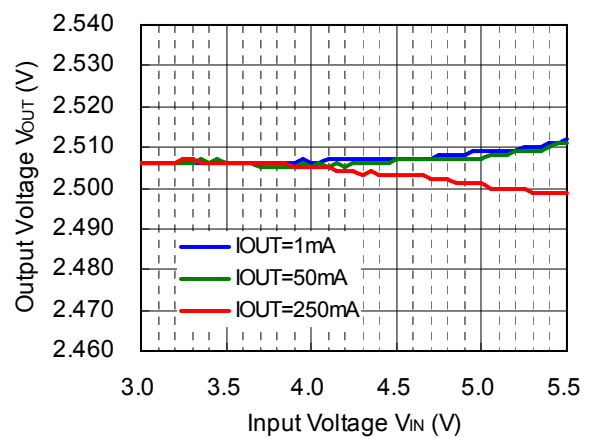

3) Output Voltage vs. Temperature

RP503x15xA

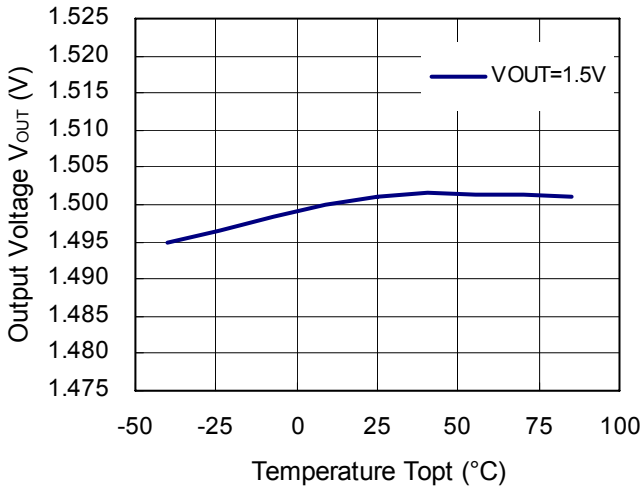

4) Efficiency vs. Output Current

RP503x08xA

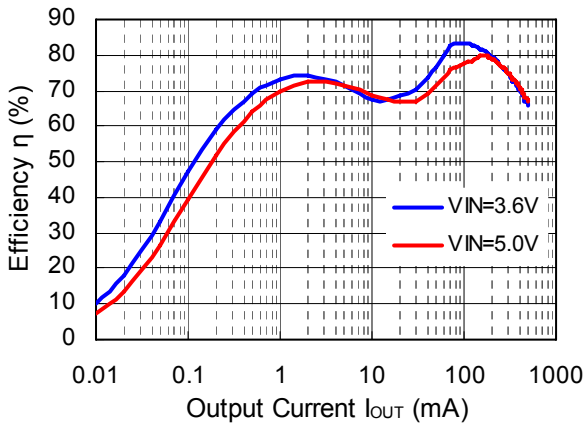

RP503x12xA

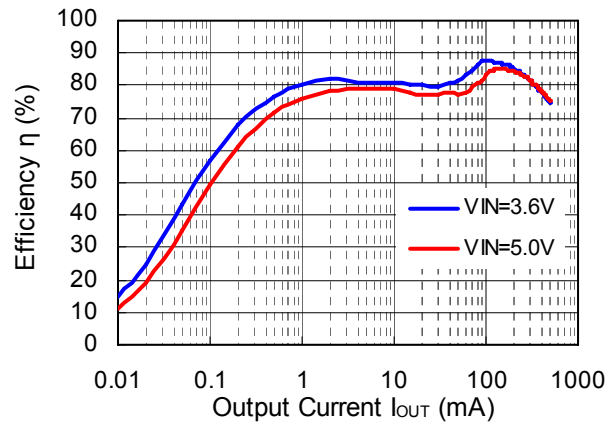

RP503x15xA

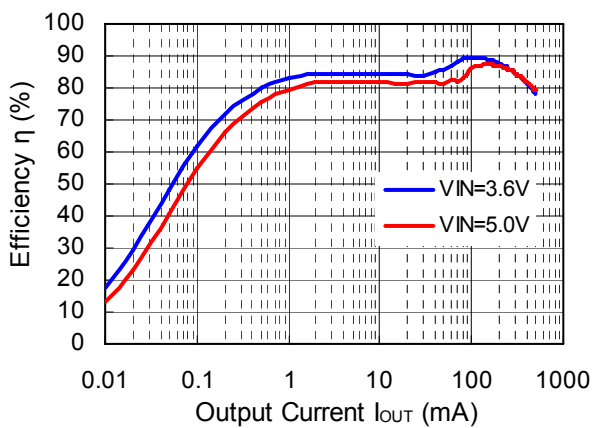

RP503x18xA

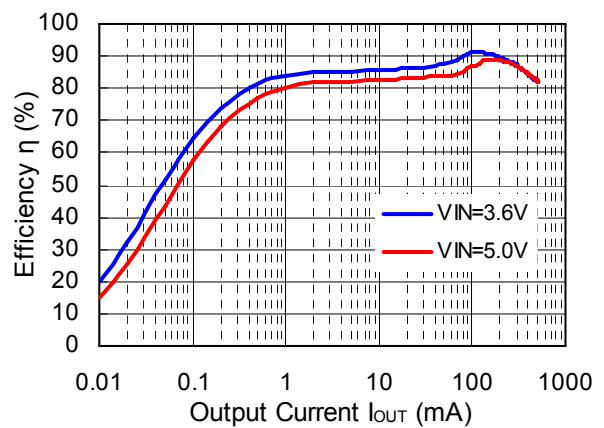

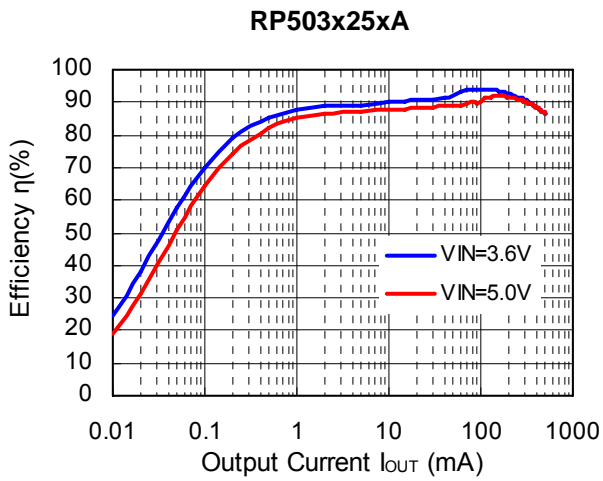

5) Supply Current 1, 2 vs. Temperature

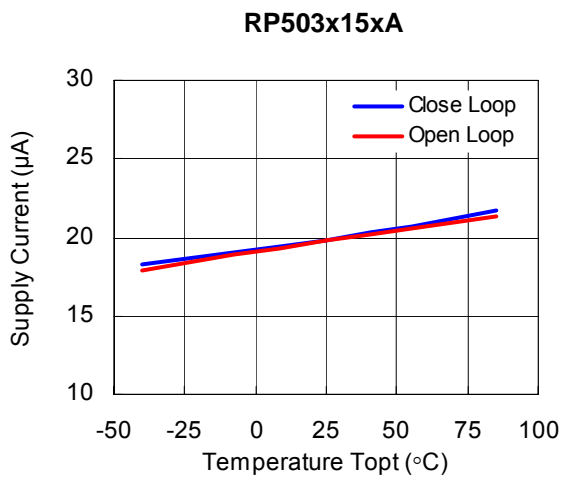

6) Supply Current 1, 2 vs. Input Voltage

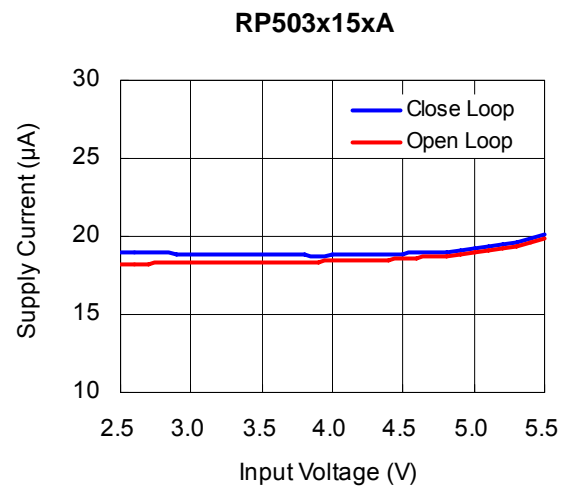

7) DC/DC Output Waveform ($V_{IN}=3.6V$, $T_{opt}=25^{\circ}C$)

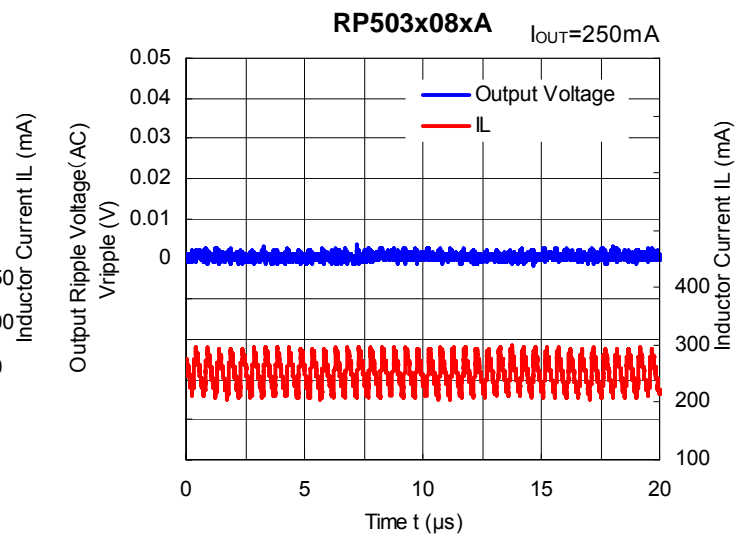
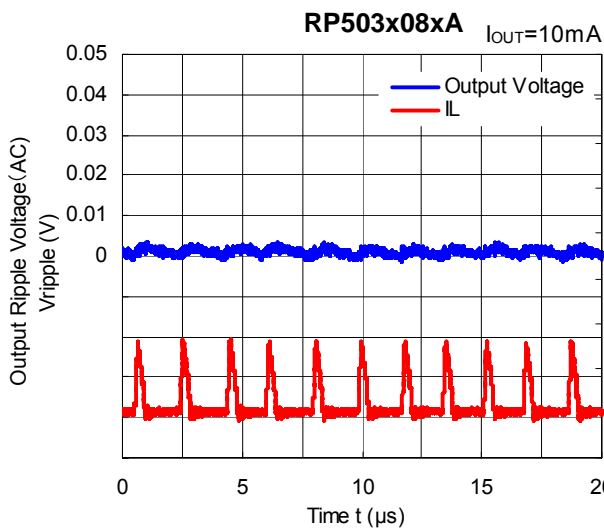

RP503x12xA

$I_{OUT}=10mA$

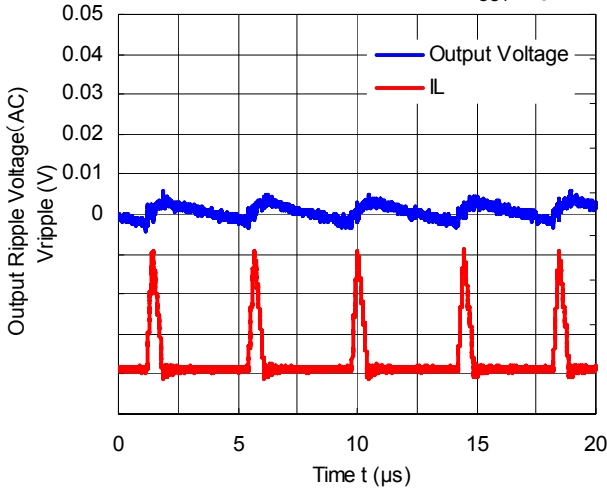

RP503x12xA

$I_{OUT}=250mA$

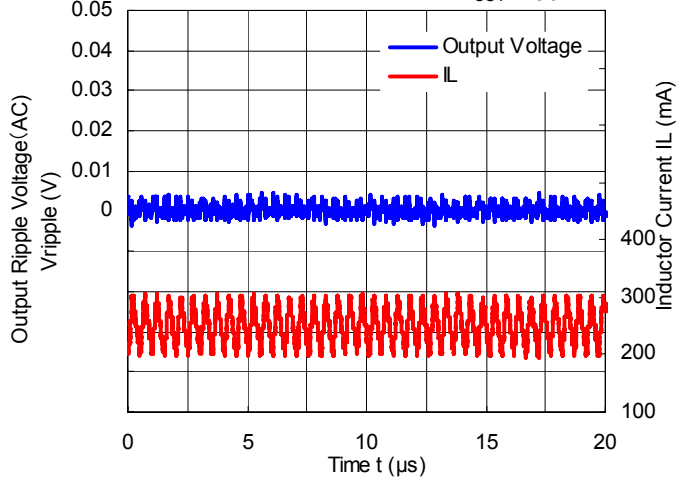

RP503x18xA

$I_{OUT}=10mA$

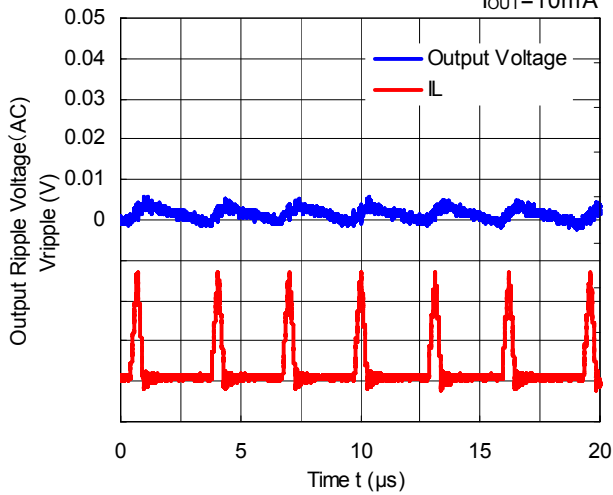

RP503x18xA

$I_{OUT}=250mA$

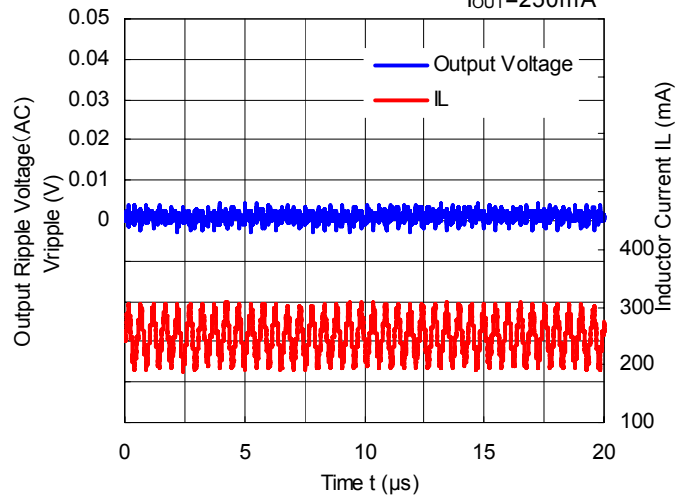

RP503x25xA

$I_{OUT}=10mA$

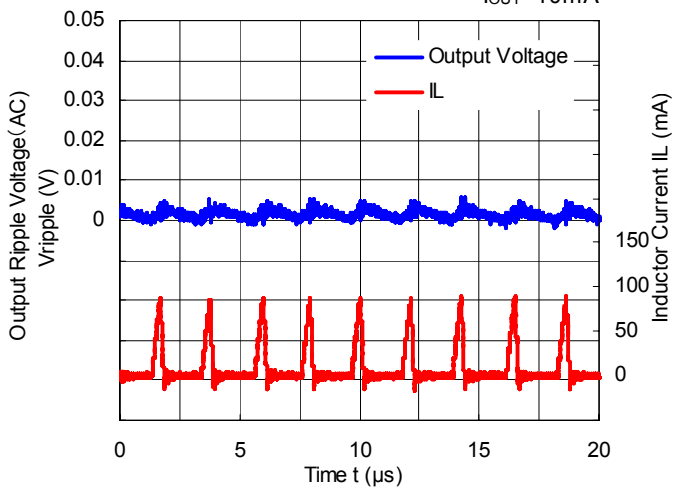

RP503x25xA

$I_{OUT}=250mA$

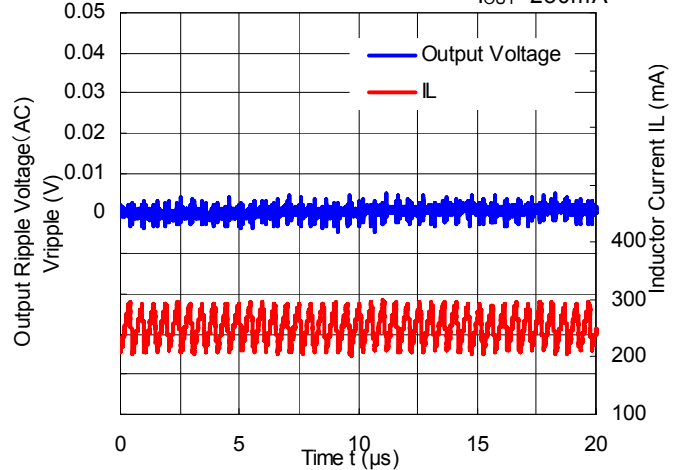

8) Oscillator Frequency vs. Temperature

RP503x15xA

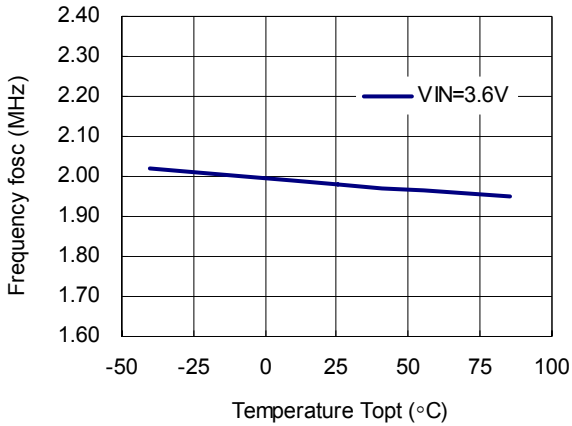

9) Oscillator Frequency vs. Input Voltage

RP503x15xA

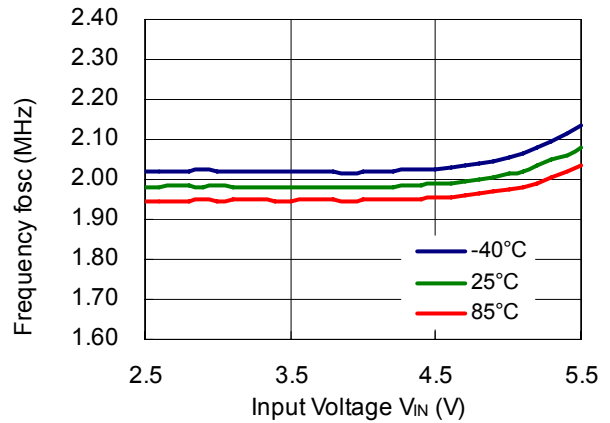

10) Soft-start Time vs. Temperature

RP503x15xA

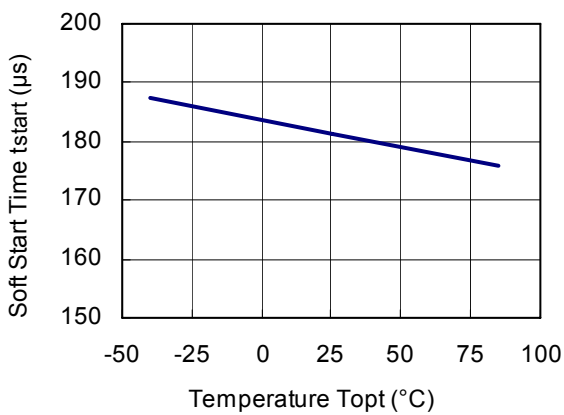

11) UVLO Detector Threshold / Released Voltage vs. Temperature

UVLO Detector Threshold

RP503x15xA

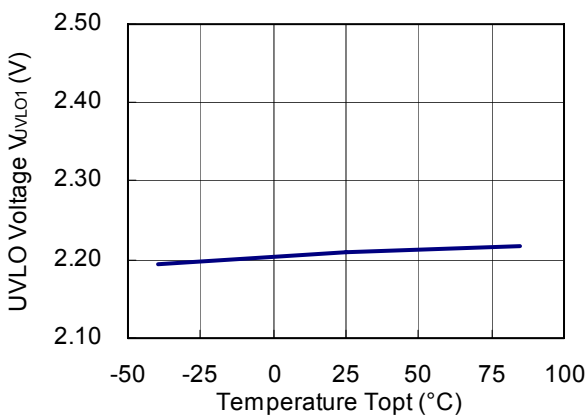

UVLO Released Voltage

RP503x15xA

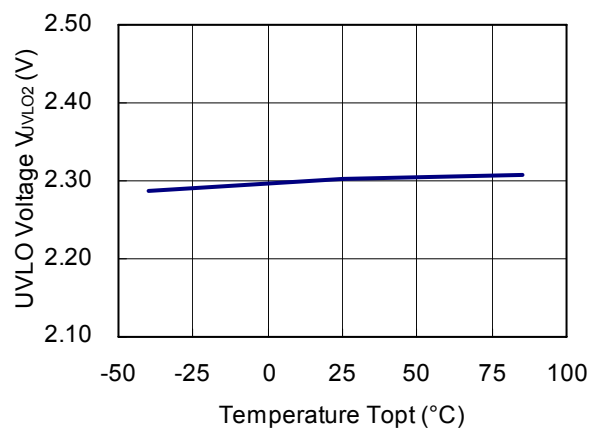

12) CE Input Voltage vs. Temperature

CE"H" Input Voltage
RP503x15xA

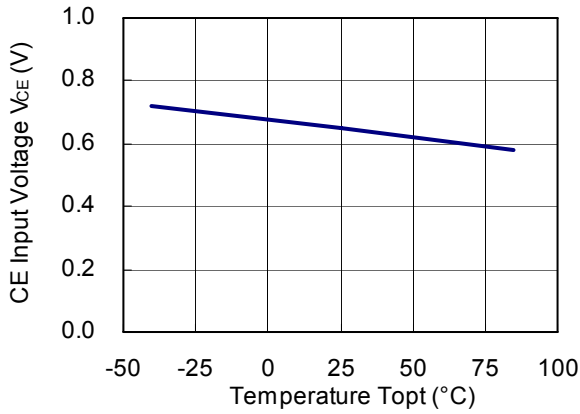

CE"L" Input Voltage
RP503x15xA

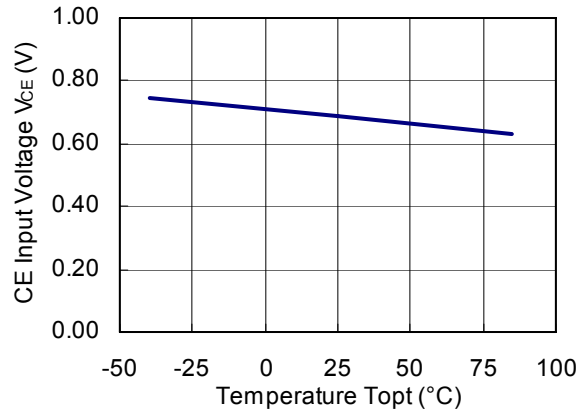

13) Lx Current Limit vs. Temperature

RP503x15xA

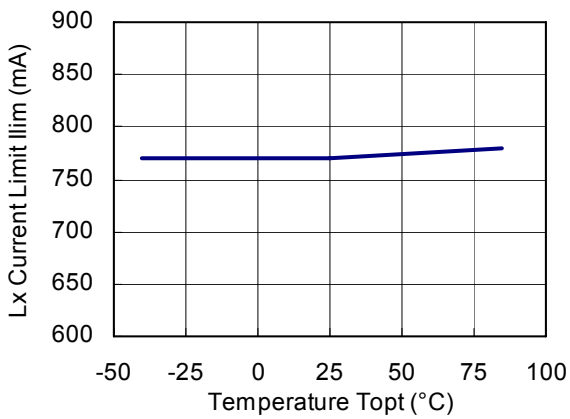

14) Nch Tr. ON Resistance vs. Temperature

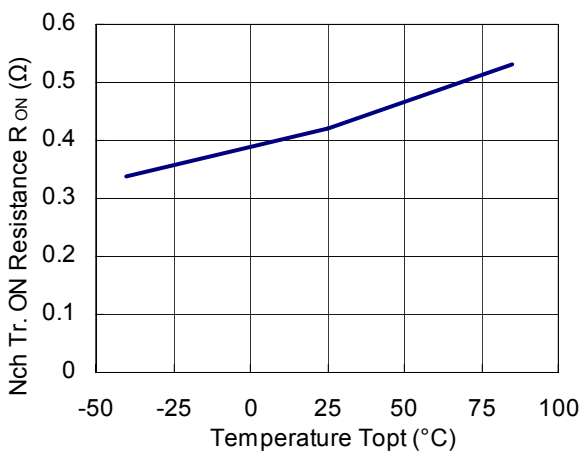

15) Pch Tr. ON Resistance vs. Temperature

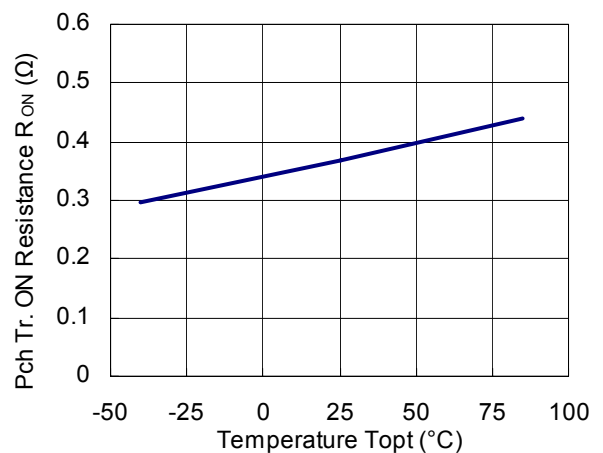

16) Turn on speed with CE pin ($V_{IN}=3.6V$, $T_{opt}=25^{\circ}C$)

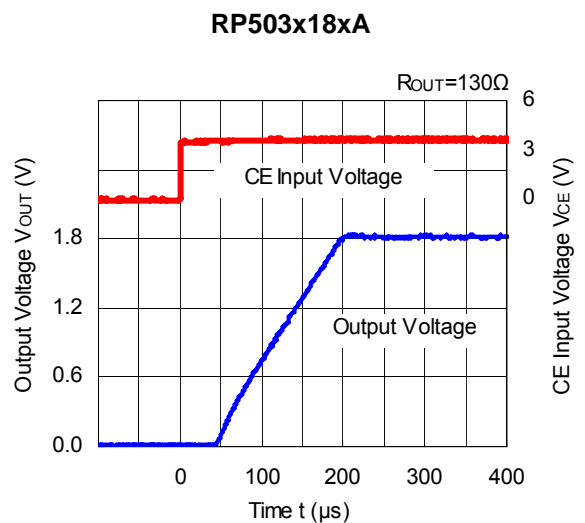
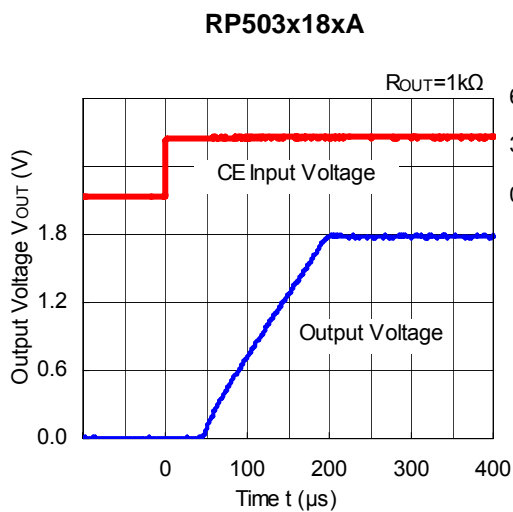
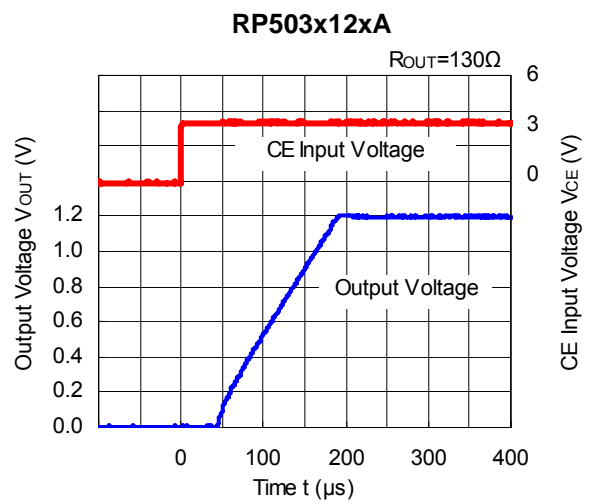
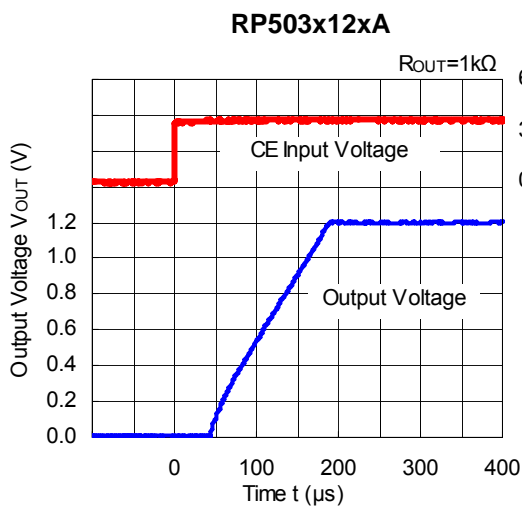
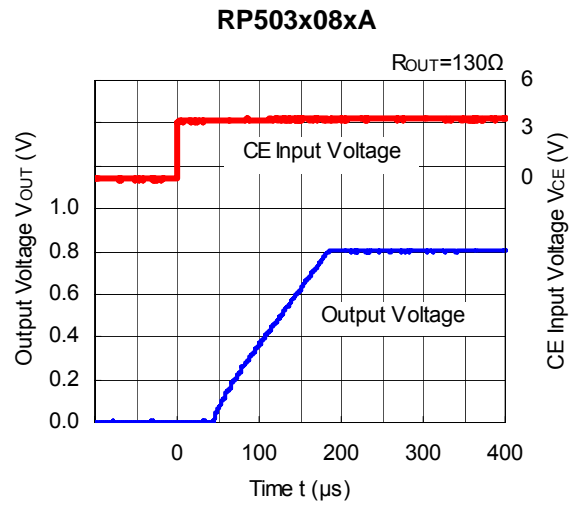
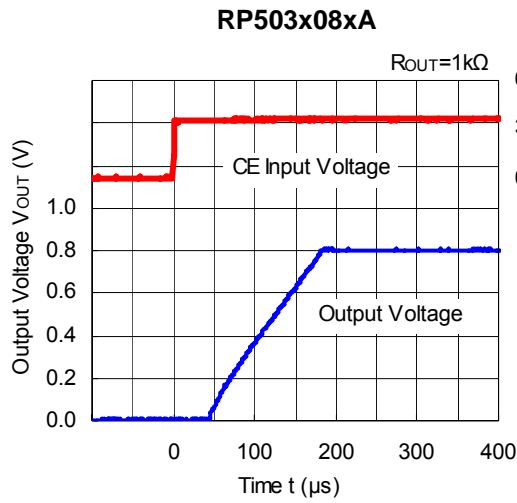

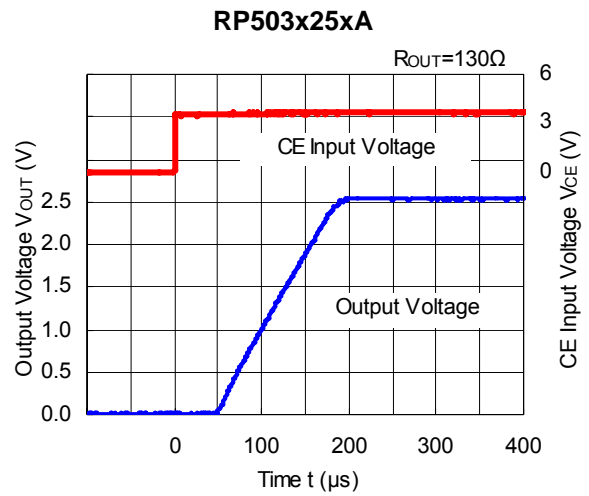
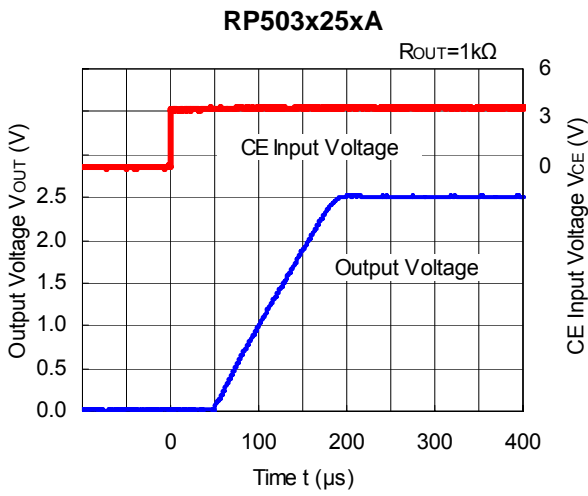

17) Load Transient Response ($V_{IN}=3.6V$, $T_{opt}=25^{\circ}C$)

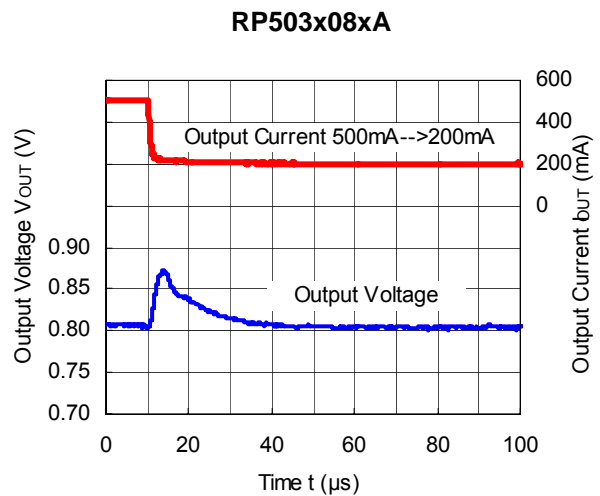
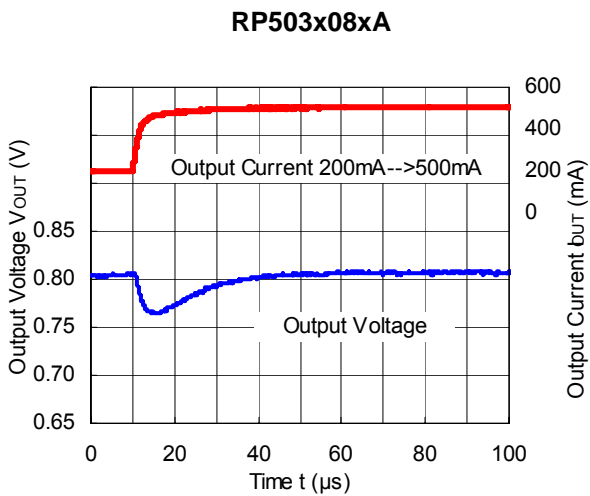
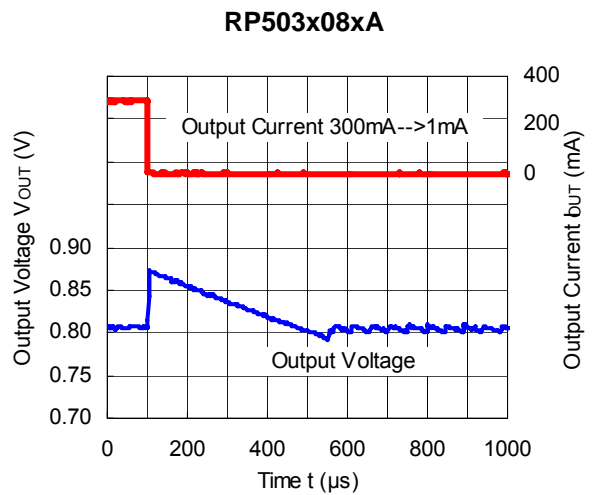
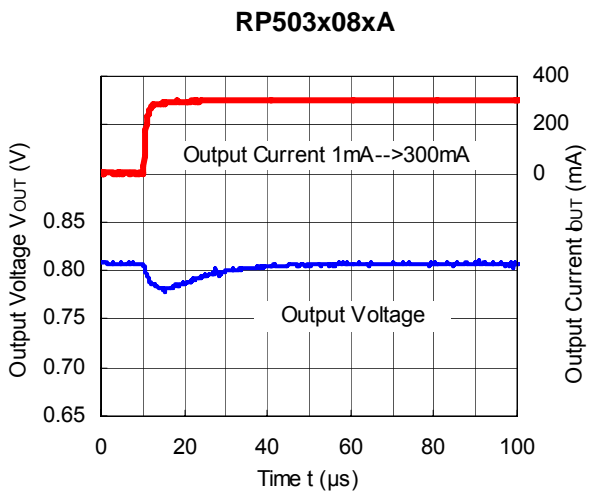

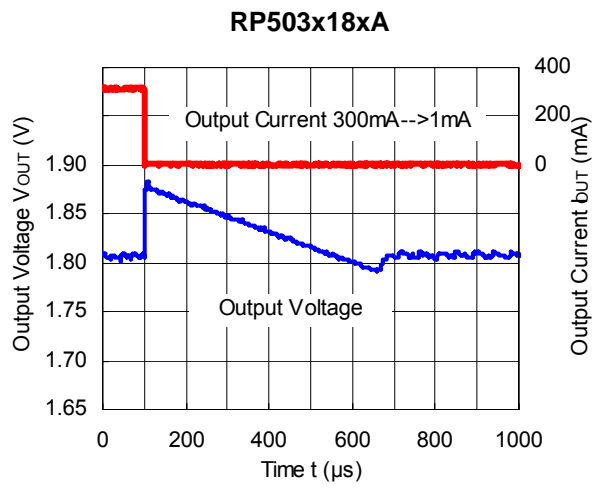
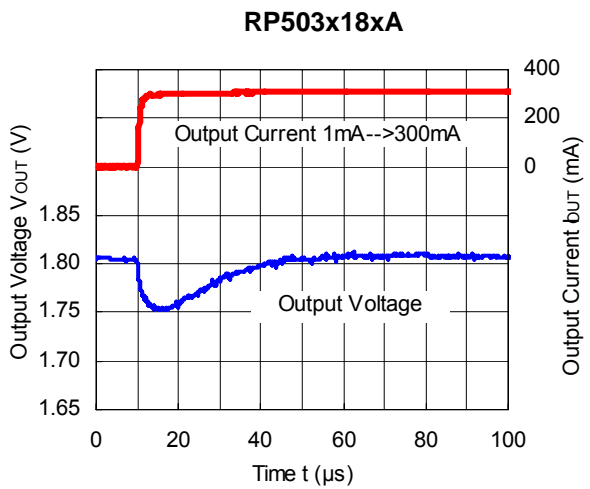
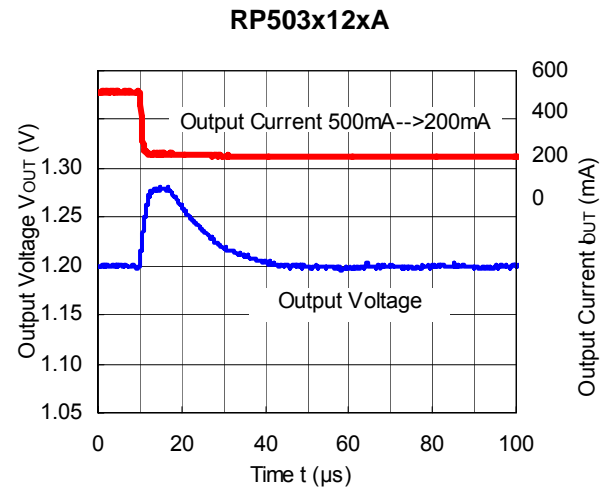
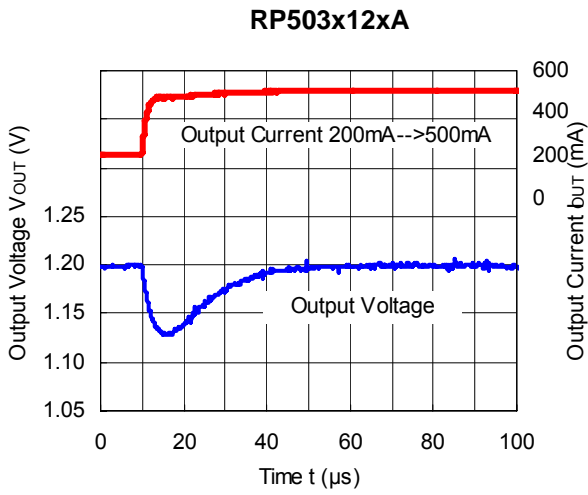
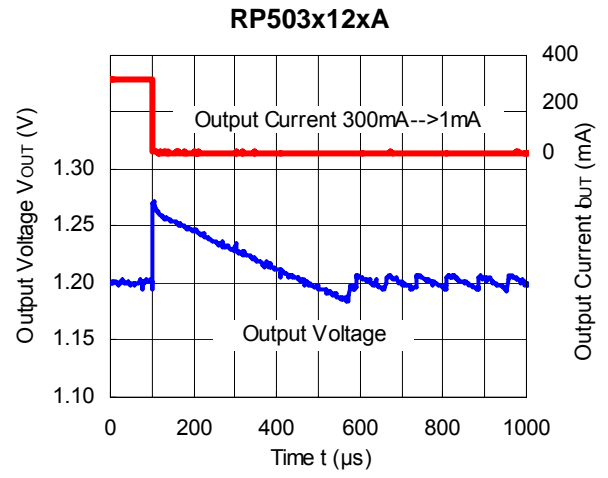
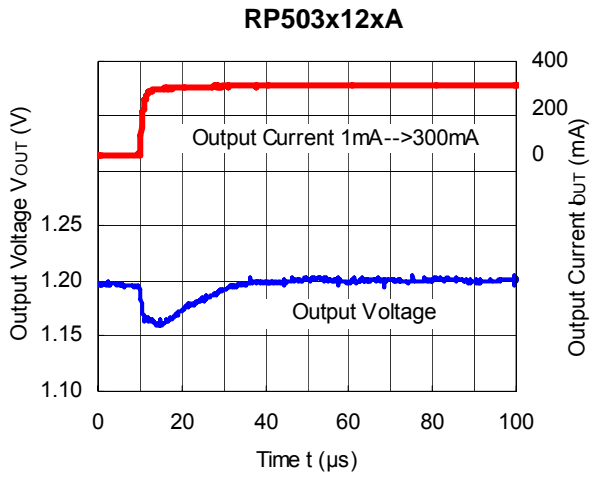

RP503x18xA

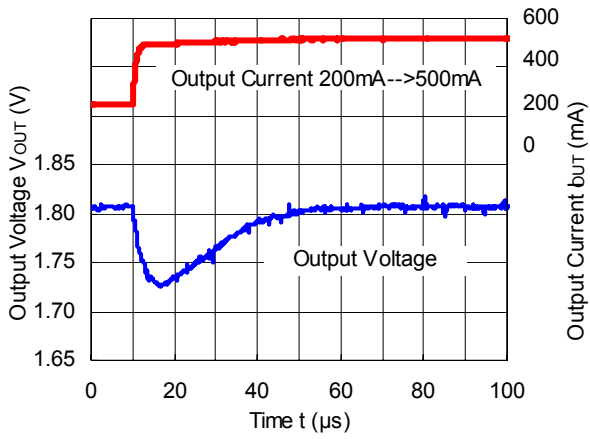

RP503x18xA

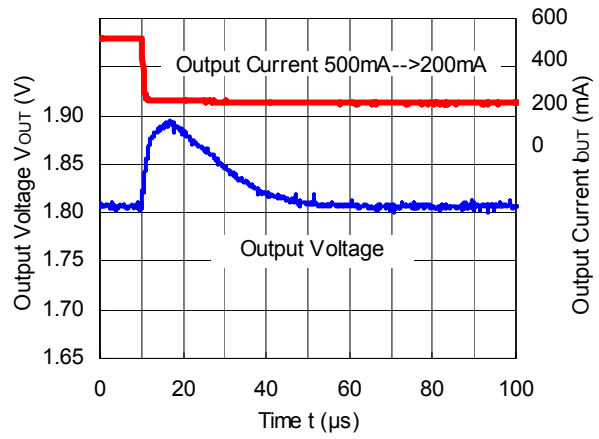

RP503x25xA

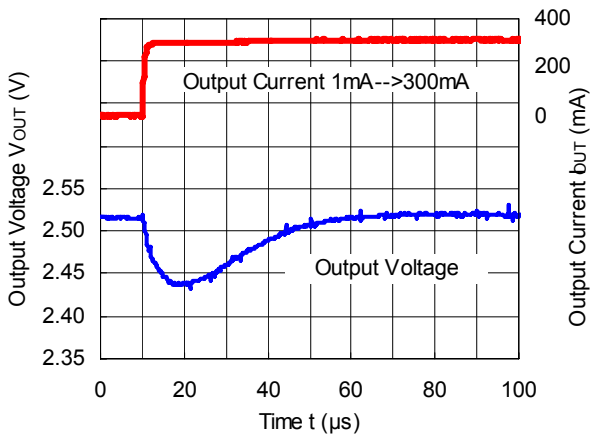

RP503x25xA

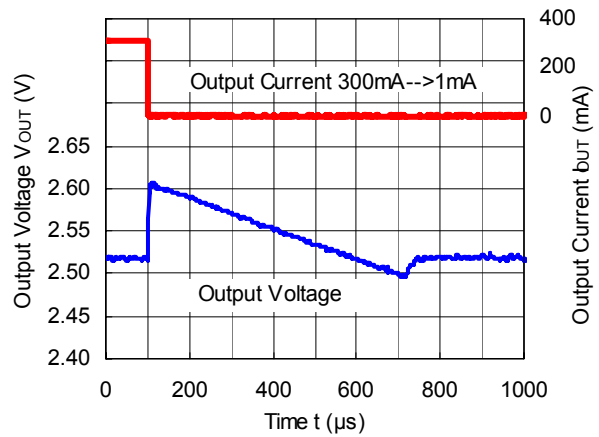

RP503x25xA

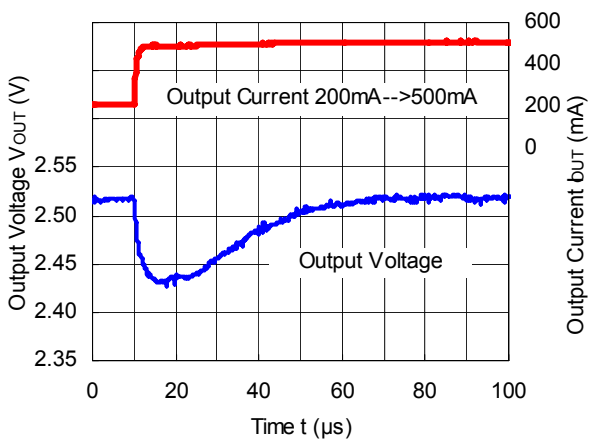

RP503x25xA

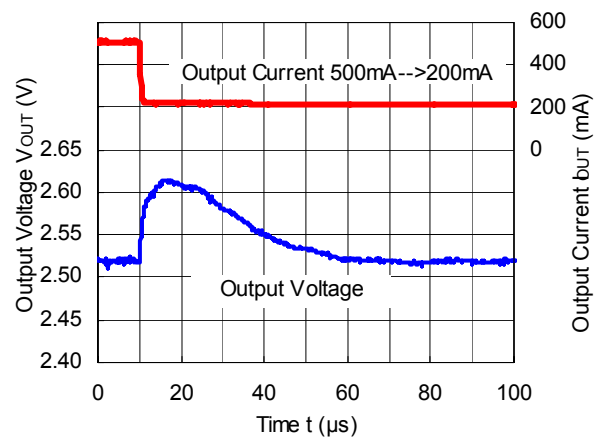



1. The products and the product specifications described in this document are subject to change or discontinuation of production without notice for reasons such as improvement. Therefore, before deciding to use the products, please refer to Ricoh sales representatives for the latest information thereon.
2. The materials in this document may not be copied or otherwise reproduced in whole or in part without prior written consent of Ricoh.
3. Please be sure to take any necessary formalities under relevant laws or regulations before exporting or otherwise taking out of your country the products or the technical information described herein.
4. The technical information described in this document shows typical characteristics of and example application circuits for the products. The release of such information is not to be construed as a warranty of or a grant of license under Ricoh's or any third party's intellectual property rights or any other rights.
5. The products listed in this document are intended and designed for use as general electronic components in standard applications (office equipment, telecommunication equipment, measuring instruments, consumer electronic products, amusement equipment etc.). Those customers intending to use a product in an application requiring extreme quality and reliability, for example, in a highly specific application where the failure or misoperation of the product could result in human injury or death (aircraft, spacevehicle, nuclear reactor control system, traffic control system, automotive and transportation equipment, combustion equipment, safety devices, life support system etc.) should first contact us.
6. We are making our continuous effort to improve the quality and reliability of our products, but semiconductor products are likely to fail with certain probability. In order to prevent any injury to persons or damages to property resulting from such failure, customers should be careful enough to incorporate safety measures in their design, such as redundancy feature, firecontainment feature and fail-safe feature. We do not assume any liability or responsibility for any loss or damage arising from misuse or inappropriate use of the products.
7. Anti-radiation design is not implemented in the products described in this document.
8. Please contact Ricoh sales representatives should you have any questions or comments concerning the products or the technical information.



For the conservation of the global environment, Ricoh is advancing the decrease of the negative environmental impact material.
After Apr. 1, 2006, we will ship out the lead free products only. Thus, all products that will be shipped from now on comply with RoHS Directive. Basically after Apr. 1, 2012, we will ship out the Power Management ICs of the Halogen Free products only. (Ricoh Halogen Free products are also Antimony Free.)

RICOH RICOH COMPANY, LTD. Electronic Devices Company

<http://www.ricoh.com/LSI/>

RICOH COMPANY, LTD.

Electronic Devices Company

● Higashi-Shinagawa Office (International Sales)

3-32-3, Higashi-Shinagawa, Shinagawa-ku, Tokyo 140-8655, Japan
Phone: +81-3-5479-2857 Fax: +81-3-5479-0502

RICOH EUROPE (NETHERLANDS) B.V.

● Semiconductor Support Centre

"Nieuw Kronenburg" Prof. W.H. Keesomlaan 1, 1183 DJ, Amstelveen, The Netherlands
P.O.Box 114, 1180 AC Amstelveen
Phone: +31-20-5474-309 Fax: +31-20-5474-791

RICOH ELECTRONIC DEVICES KOREA Co., Ltd.

11 floor, Haesung 1 building, 942, Daechidong, Gangnamgu, Seoul, Korea
Phone: +82-2-2135-5700 Fax: +82-2-2135-5705

RICOH ELECTRONIC DEVICES SHANGHAI Co., Ltd.

Room403, No.2 Building, 690#Bi Bo Road, Pu Dong New district, Shanghai 201203,
People's Republic of China
Phone: +86-21-5027-3200 Fax: +86-21-5027-3299

RICOH COMPANY, LTD.

Electronic Devices Company

● Taipei office

Room109, 10F-1, No.51, Hengyang Rd., Taipei City, Taiwan (R.O.C.)
Phone: +886-2-2313-1621/1622 Fax: +886-2-2313-1623