Description

The CXA3757GF is a 4ch LED controller at high efficiency with a voltage boost type DC-DC converter. This IC has a built-in function of controller for each LEDs connected to the 4-channel outputs at the minimum necessary voltage (Max. VF detection function). (For details, see page 7.)
(Applications: Portable equipment, etc.)

Features

- ◆ 4-channel outputs (4ch/3ch selectable)
- ◆ Capable of drive up to 80mA (20mA per channel)
- ◆ Max. VF detection function allows high efficiency LED driving
- ◆ PWM input luminance adjustment function
- ◆ Operation protection with voltage boost type DC-DC converter (with overvoltage and TSD protection function)
- ◆ Operating voltage range 2.0V to 4.8V supported
- ◆ 1.5 × 2.0mm small package size (12-pin, WLP)
- ◆ Small chip coil can be supported

Structure

CMOS silicon monolithic IC

Absolute Maximum Ratings

(Ta = 25°C)

| | | | |
|-------------------------|------|-------------------|----|
| ◆ Supply voltage | AVcc | GND – 0.3 to +5.5 | V |
| ◆ Operating temperature | Topr | –30 to +85 | °C |
| ◆ Storage temperature | Tstg | –55 to +150 | °C |

Recommended Operating Conditions

| | | | |
|-------------------------|------|------------|----|
| ◆ Supply voltage | AVcc | 2.0 to 4.8 | V |
| ◆ Operating temperature | Topr | –30 to +85 | °C |

Sony reserves the right to change products and specifications without prior notice. This information does not convey any license by any implication or otherwise under any patents or other right. Application circuits shown, if any, are typical examples illustrating the operation of the devices. Sony cannot assume responsibility for any problems arising out of the use of these circuits.

Block Diagram

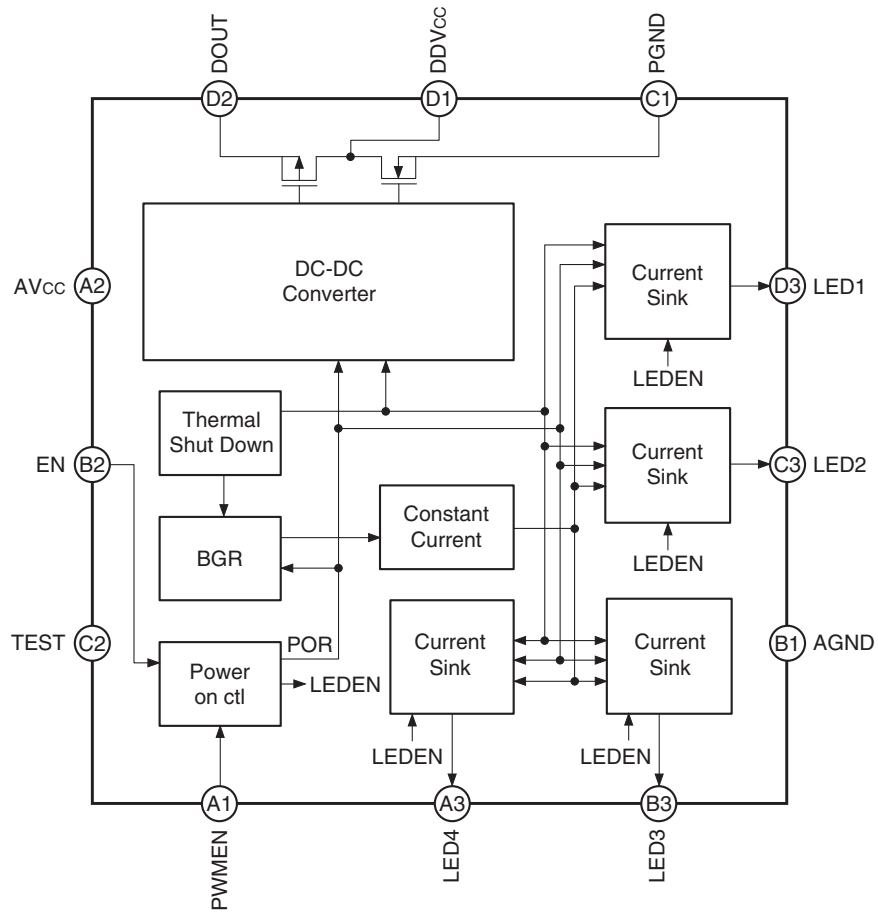

Pin Configuration

(Top View)

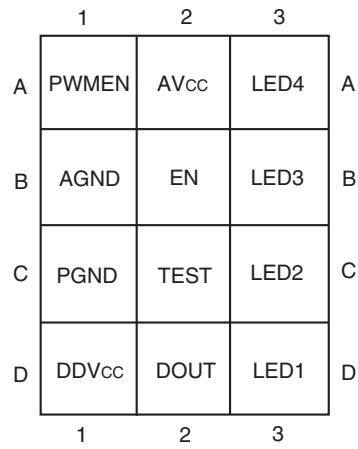

List of Pins

| Pin No. | Symbol | I/O | Description | Pin No. | Symbol | I/O | Description |
|---------|--------|-----|-------------------------------------|---------|--------|-----|------------------------|
| A1 | PWMEN | I | LED luminance adjustment | B1 | AGND | G | Analog GND |
| B2 | EN | I | Enable | D2 | DOUT | O | DC-DC converter output |
| C2 | TEST | I | TEST input (Fixed to GND when used) | C1 | PGND | G | DC-DC converter GND |
| A2 | AVcc | P | Analog power supply | D1 | DDVcc | I | DC-DC converter input |
| A3 | LED4 | O | LED connection 4 | B3 | LED3 | O | LED connection 3 |
| C3 | LED2 | O | LED connection 2 | D3 | LED1 | O | LED connection 1 |

Pin Description

| Pin No. | Symbol | I/O | Standard pin voltage | Equivalent circuit | Description |
|---------|--------|-----|----------------------|--------------------|-------------------------------------|
| A1 | PWMEN | I | GND to AVcc | | LED luminance adjustment |
| B2 | EN | I | GND to AVcc | | Enable |
| C2 | TEST | I | GND to AVcc | | TEST input (Fixed to GND when used) |
| A2 | AVcc | — | GND to AVcc | — | Analog power supply |
| D2 | DOUT | O | GND to 4.8V | | DC-DC converter output |

| Pin No. | Symbol | I/O | Standard pin voltage | Equivalent circuit | Description |
|---------|--------|-----|----------------------|--------------------|-----------------------|
| D1 | DDVcc | I | GND to DOUT | | DC-DC converter input |
| D3 | LED1 | O | 0.05V to (DOUT - VF) | | LED connection |
| C3 | LED2 | O | | | |
| B3 | LED3 | O | | | |
| A3 | LED4 | O | 0.05V to (DOUT - VF) | | LED connection |
| B1 | AGND | — | GND | — | Analog GND |
| C1 | PGND | — | GND | — | DC-DC converter GND |

Electrical Characteristics

(Unless otherwise specified, $AV_{CC} = 3.6V$, $T_a = 25^{\circ}C$)

Circuit Current

| Item | Symbol | Conditions | Min. | Typ. | Max. | Unit |
|---|-------------|--|------|------|------|---------|
| Current consumption in standby mode | I_{RESET} | $AV_{CC} = 3.6V$, $EN = L$ | — | 0 | 1 | μA |
| Current consumption 1 in operation mode | I_{CC1} | $AV_{CC} = 3.6V$, $EN = H$, $PWMEN = L$ (LED OFF) | — | 0.5 | 0.8 | mA |
| Current consumption 2 in operation mode | I_{CC2} | $AV_{CC} = 3.6V$, $EN = H$, $PWMEN = H$ (4ch LED ON) | — | 0.9 | 1.6 | mA |

DC-DC Converter Block

| Item | Symbol | Conditions | Min. | Typ. | Max. | Unit |
|------------------------------------|-------------|-------------------------------------|------|------|------|------|
| Maximum output current | I_{DCOUT} | — | 80 | — | — | mA |
| Conversion efficiency | η | $I_{DCOUT} = 80mA$, $AV_{CC} = 3V$ | 80 | 90 | — | % |
| PWM oscillation frequency | f_{osc} | — | 0.8 | 1.0 | 1.2 | MHz |
| Overvoltage detection | V_{DCLM} | — | 4.5 | 4.75 | 5.0 | V |
| Input peak current detection | V_{IPEAK} | $AV_{CC} = 3V$ | — | 500 | — | mA |
| LED voltage when voltage boosted*1 | V_{LED} | When in MAX VF mode, $AV_{CC} = 3V$ | — | 0.14 | 0.28 | V |

*1 See LED voltage on page 8.

ENABLE

| Item | Symbol | Conditions | Min. | Typ. | Max. | Unit |
|---------------------------|-----------|------------|------|------|------|------|
| PWM input frequency range | F_{PWM} | — | 0.1 | — | 1 | kHz |

Logic Block

| Item | Symbol | Conditions | Min. | Typ. | Max. | Unit |
|--------------------------|-----------|-----------------------|------|------|-----------|-----------|
| High level input voltage | V_{LIH} | EN, PWMEN each pin | 1.2 | — | AV_{CC} | V |
| Low level input voltage | V_{LIL} | | −0.3 | — | 0.4 | V |
| Input pull-down resistor | R_{EN} | | 200 | 300 | — | $k\Omega$ |

LED Driver Block

| Item | Symbol | Conditions | Min. | Typ. | Max. | Unit |
|--------------------|------------|------------------------------|------|------|------|---------|
| Max. drive current | I_{OUT} | Per 1ch output | 19 | 20 | 21 | mA |
| Output leakage | I_{LEAK} | When LED output voltage 3.6V | — | 0 | 1 | μA |

Description of Operation

1. Operation Mode

When input voltage is higher than the voltage required to turn on LED, this IC does not perform boost operation, and then outputs the input voltage as it is to DOUT. (Through mode)

When input voltage is less than the voltage required to turn on LED, this IC performs voltage boost operation to the minimum necessary voltage to turn on LED and output to DOUT. (Max. VF mode)

Through mode and Max. VF mode can be switched automatically within IC.

2. Boost Operation

When even 1 channel of the 4 channels of LED connection pins cannot hold constant current by LED driver, the internal DC-DC converter circuit turns on and the Max. VF detection circuit operates. This Max. VF detection operation controls the DC-DC converter output voltage to the minimum necessary voltage in accordance with the lighting status of all the connected LEDs.

This makes it possible to drive the various LEDs at high efficiency.

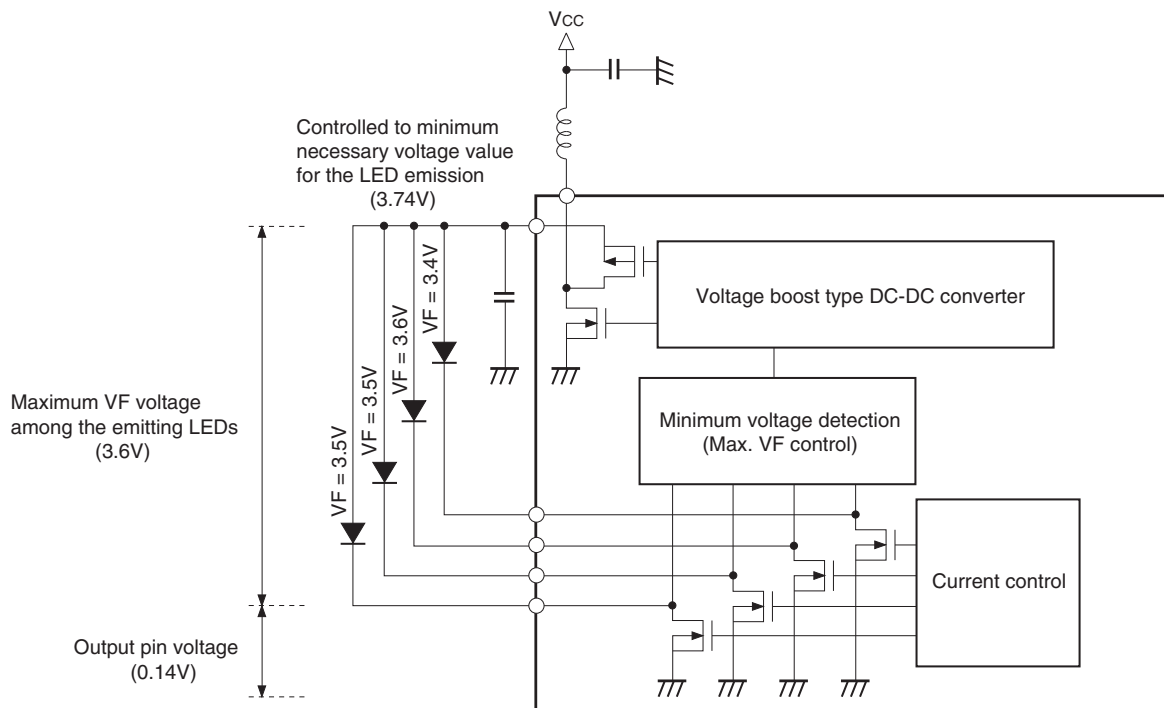

Example of LED Max. VF Detection Operation

3. Start-up Characteristics

This IC does not consume current from AVcc power-on until EN pin is set from Low to High. (Standby mode)

Start-up characteristics in through mode

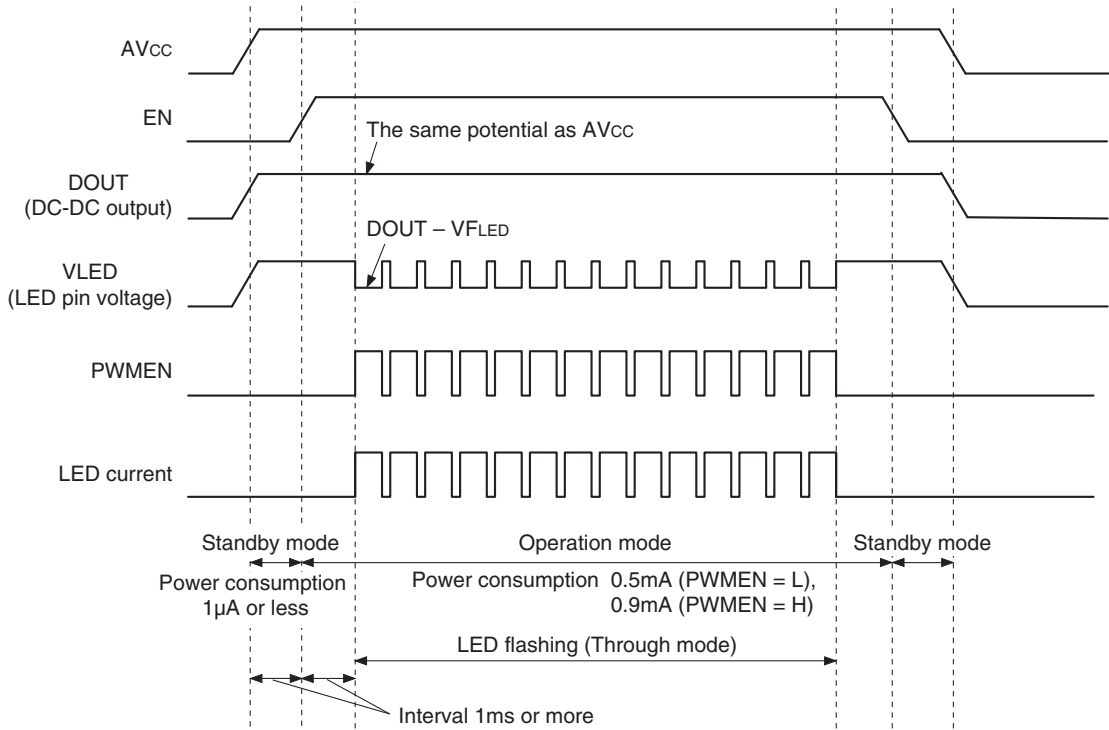

Start-up characteristics in Max. VF mode

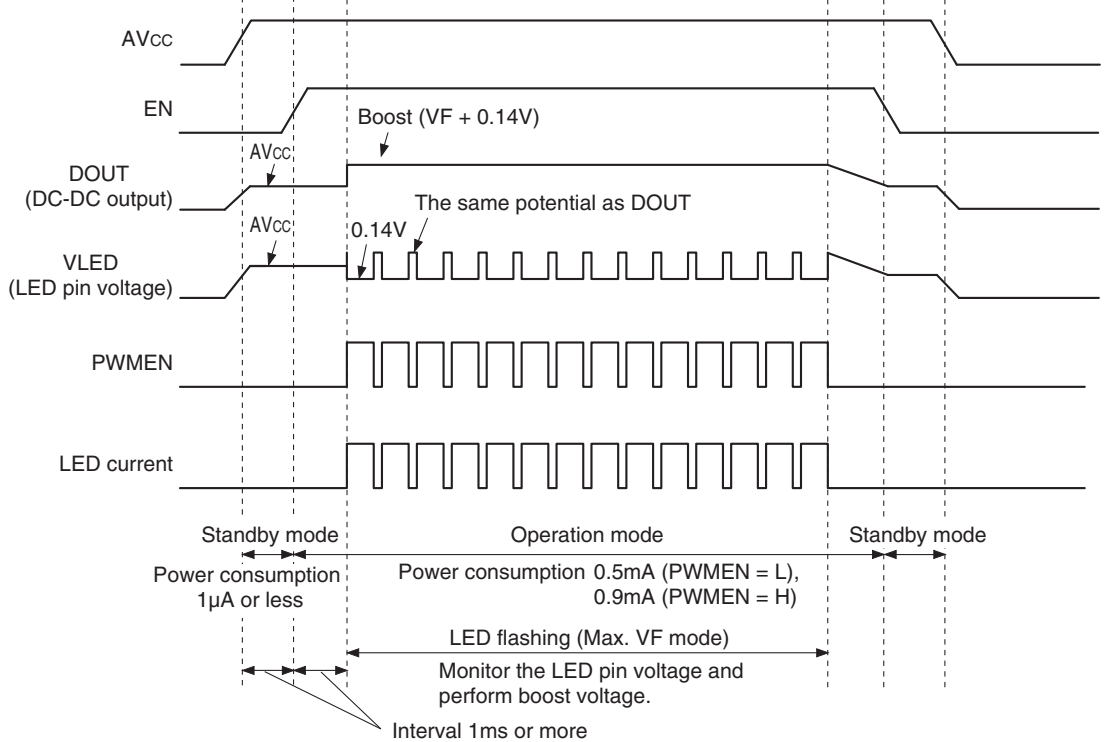

4. Inductor Selection

The recommended inductance value is 4.2μH.

Note that the relationship between the output current capacity and the inductance value can be obtained by the following formula.

$$I_{DCOUT(MAX)} = \eta \times \left\{ I_P - \left(\frac{V_{IN} \times D}{f \times L \times 2} \right) \right\} \times (1 - D)$$

- η = Estimated efficiency
- I_P = Peak current limit value
- V_{IN} = Input voltage
- D = Steady – state duty ratio
- f = Switching frequency (Typ.: 1.0MHz)
- L = Inductance value

5. Capacitor Selection

a) Input capacitor

The input capacitor stabilizes the input voltage and averages the input current, making it possible to improve the efficiency. For this reason, use a capacitor with low ESR.

The recommended capacitance value is 4.7μF (B constant tolerance).

b) Output capacitor

The output capacitor holds the output voltage when the internal Nch transistor turns ON, and smoothes the ripple voltage. For this reason, use a capacitor with low ESR.

The recommended capacitance value is 4.7μF (B constant tolerance).

6. Processing When Using 3ch

When using 3ch, connect LED4 pin to DOUT.

The CXA3757GF detects connection to DOUT internally and sets the channel not to input current.

This results in operation using 3ch.

7. LED Luminance Adjustment

LED luminance can be adjusted by changing the pulse duty input to PWMEN pin.

The pulse frequency input to PWMEN pin can be supported within the range of 0.1kHz to 1kHz.

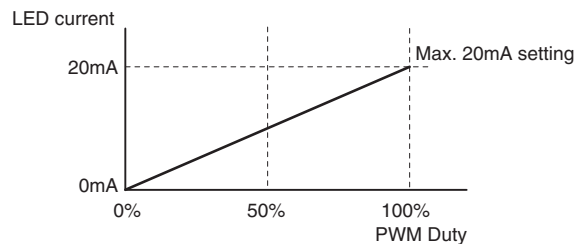

8. Operation during LED Open Failure

At Max. V_F mode operation, the DC-DC converter circuit monitors all the LED connection pins and supplies the minimum necessary voltage, so when an LED open failure occurs, the DC-DC converter output voltage rises and detects overvoltage.

After that the DC-DC converter output is controlled by overvoltage detection value (approximate 4.75V).

9. Thermal Shutdown

This IC is provided with a thermal shutdown circuit which shuts down the DC-DC converter circuit and all LED drive circuits when the IC junction temperature reaches approximately 150°C.

Application Circuit

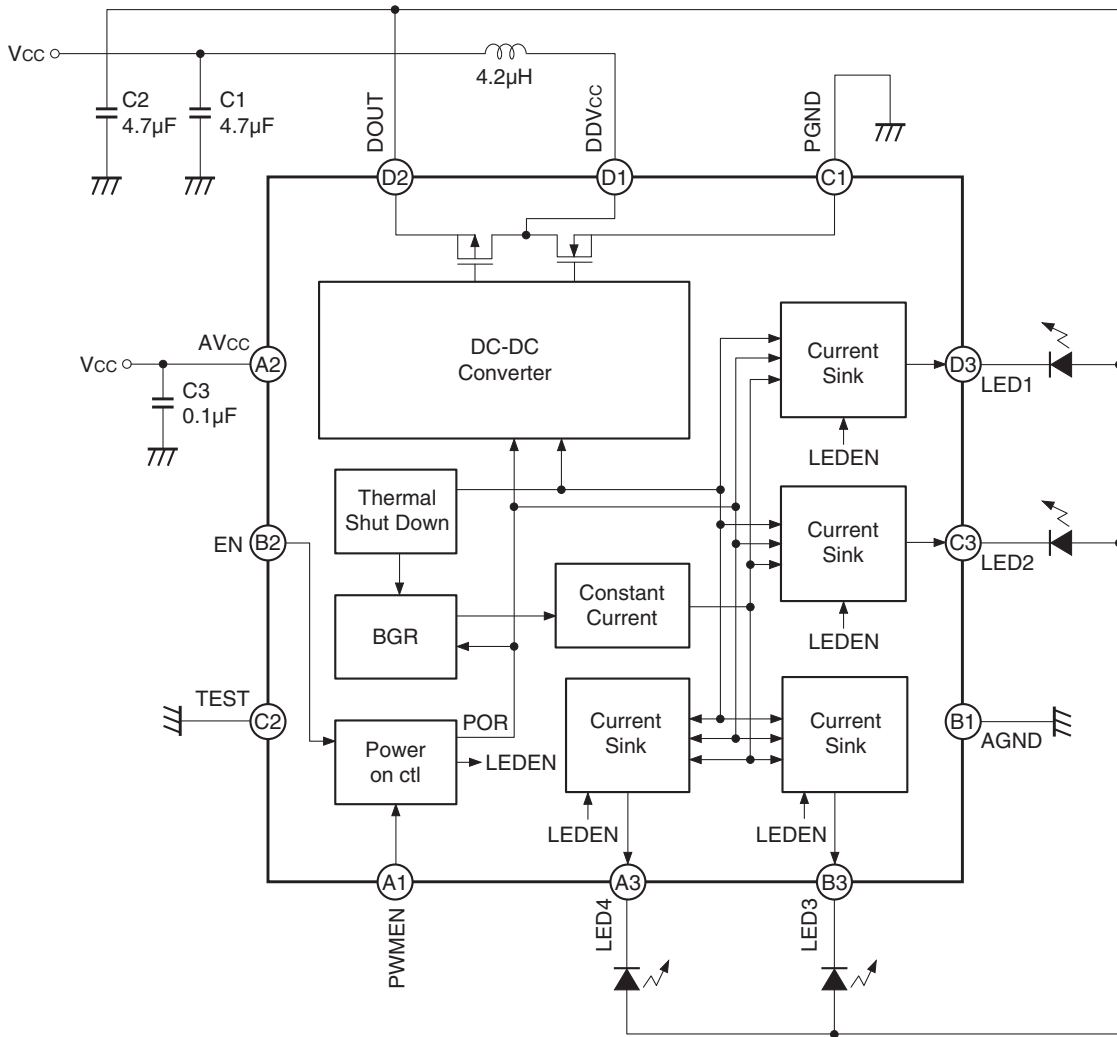

Recommended External Elements

- LED : NSSW020BT (nichia)
- L (4.2µH) : MIPWT3226D4R2 (FDK)
- C1, 2 (4.7µF) : GRM188B30J475KE18D (murata)
- C3 (0.1µF) : GRM033B30J104KE18D (murata)

Recommended Board Pattern

1. Pattern wiring
As for wiring for DDVcc pin and GND wiring for PGND, avoid sharing with other wiring.
2. Component layout
When uses determine the board layout, the trace length to the resistor of the inductor, input and output capacitors should be as short as possible.
Also, locate the power supply bypass capacitors as close to the IC as possible.

Application circuits shown are typical examples illustrating the operation of the devices. Sony cannot assume responsibility for any problems arising out of the use of these circuits or for any infringement of third party patent and other right due to same.

