



Asynchronous Communications Interface Adapter (ACIA)



WDC reserves the right to make changes at any time without notice in order to improve design and supply the best possible product. Information contained herein is provided gratuitously and without liability, to any user. Reasonable efforts have been made to verify the accuracy of the information but no guarantee whatsoever is given as to the accuracy or as to its applicability to particular uses. In every instance, it must be the responsibility of the user to determine the suitability of the products for each application. WDC products are not authorized for use as critical components in life support devices or systems. Nothing contained herein shall be construed as a recommendation to use any product in violation of existing patents or other rights of third parties. The sale of any WDC product is subject to all WDC Terms and Conditions of Sales and Sales Policies, copies of which are available upon request.

Copyright ©1981 2010 by The Western Design Center, Inc. All rights reserved, including the right of reproduction, in whole, or in part, in any form.



INTRODUCTION

The WDC CMOS W65C51N Asynchronous Communications Interface Adapter (ACIA) provides an easily implemented, program controlled interface between 8-bit microprocessor based systems and serial communication data sets and modems.

The ACIA has an internal baud rate generator. This feature eliminates the need for multiple component support circuits, a crystal being the only other part required. The Transmitter baud rate can be selected under program control to be either 1 of 15 different rates from 50 to 19,200 baud, or at 1/16 times an external clock rate. The Receiver baud rate may be selected under program control to be either the Transmitter rate or at 1/16 times the external clock rate. The ACIA has programmable word lengths of 5, 6, 7 or 8 bits; even, odd or no parity (Mark Parity only for Transmitter); 1, 1½ or 2 bit stops.

The ACIA is designed for maximum-programmed control from the microprocessor (MPU) to simplify hardware implementation. Three separate registers permit the MPU to easily select the W65C51N operating modes and data checking parameters and determine operational status.

The Command Register controls parity, receiver echo mode, transmitter interrupt control, the state of the RTSB line, receiver interrupt control and the state of the DTRB line.

The Control Register controls the number of stop bits, word length, receiver clock source and baud rate.

The Status Register indicates the states of the IRQB, DSRB, and DCDB lines, Transmitter and Receiver Data Registers and Overrun, Framing and Parity Error conditions.

The Transmitter and Receiver Data Registers are used for temporary data storage by the ACIA Transmit and Receive circuits.

FEATURES

- Low power CMOS N-well silicon gate technology
- Replacement for CMD / GTE / Harris / MOS Technology / GE / RCA / Synertek / Motorola / Rockwell R6551, G65SC51, 65C51, 6551, CPD65C51, 6850
- Full duplex operation with buffered receiver and transmitter
- Data set/modem control functions
- Internal baud rate generator with 15 programmable baud rates (50 to 19,200)
- Program-selectable internally or externally controlled receiver rate
- Programmable word lengths, number of stop bits and parity bit generation and detection
- Programmable interrupt control
- Program reset
- Program-selectable serial echo mode
- Two chip selects
- 5.0 VDC ± 5% supply requirements
- 28 pin plastic DIP package
- 32 pin LQFP package
- Full TTL compatibility
- Compatible with 65xx and 68xx microprocessors

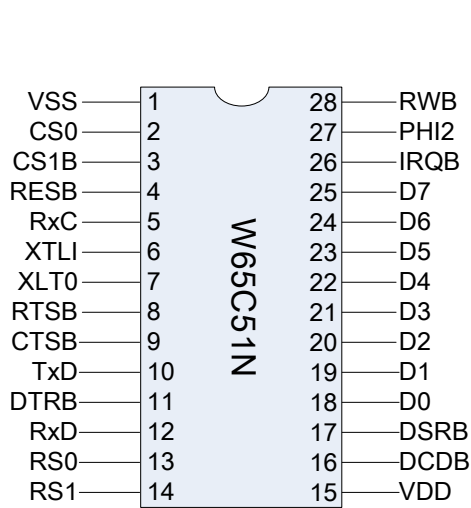

Figure 1a 28 Pin PDIP Pin Out

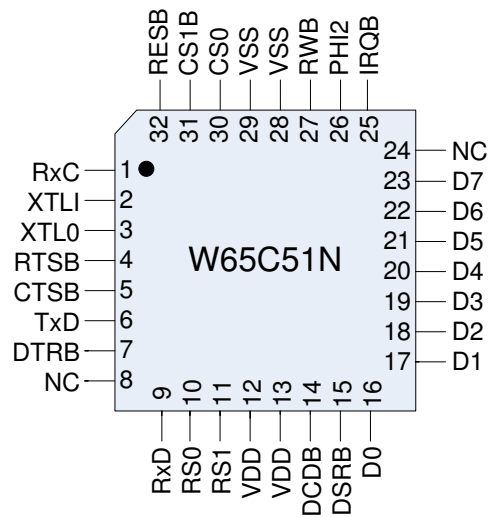

Figure 1b 32 Pin LQFP Pin Out

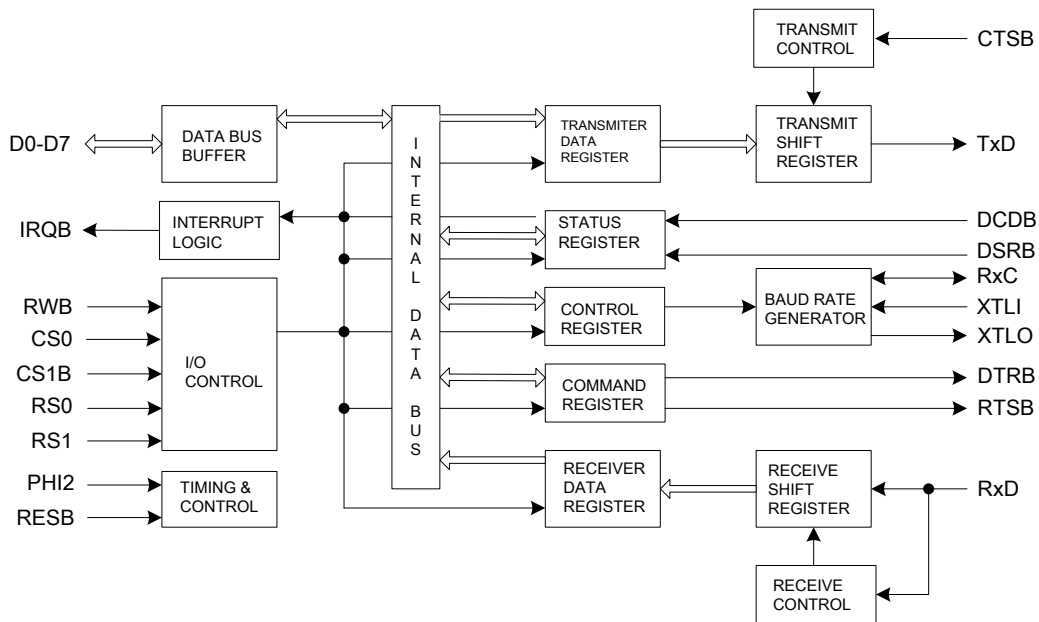

Figure 2 ACIA Internal Organization



FUNCTIONAL DESCRIPTION

A block diagram of the ACIA is presented in Figure 3 followed by a description of each functional element of the device.

DATA BUS BUFFERS

The Data Bus Buffer interfaces the system data lines to the internal data bus. The Data Bus Buffer is bi-directional. When the RWB line is high and the chip is selected, the Data Bus Buffer passes the data from the system data lines to the ACIA internal data bus. When the RWB line is low and the chip is selected, the Data Bus Buffer writes the data from the internal data bus to the system data bus.

INTERRUPT LOGIC

The Interrupt Logic will cause the IRQB line to the microprocessor to go low when conditions are met that require the attention of the microprocessor. The conditions which can cause an interrupt will set bit 7 and the appropriate bit of bits 3 through 6 in the Status Register, if enabled. Bits 5 and 6 correspond to the Data Carrier Detect (DCDB) logic and the Data Set Ready (DSRB) logic. Bits 3 and 4 correspond to the Receiver Data Register full and the Transmitter Data Register empty conditions. These conditions can cause an interrupt request if enabled by the Command Register.

I/O CONTROL

The I/O Control Logic controls the selection of internal registers in preparation for a data transfer on the internal data bus and the direction of the transfer to or from the register. The registers are selected by the Register Select (RS1, RS0) and Read/Write (RWB) lines as described later in Table 1.

TIMING AND CONTROL

The Timing and Control logic controls the timing of data transfers on the internal data bus and the registers, the Data Bus Buffer and the microprocessor data bus and hardware reset features.

Timing is controlled by the system PHI2 clock input. The chip will perform data transfers to or from the microcomputer data bus during the PHI2 high period when selected.

The Timing and Control Logic will initialize all registers when the Reset (RESB) line goes low. See the individual register description for the state of the registers following a hardware reset.

TRANSMITTER AND RECEIVER DATA REGISTERS

These registers are used as temporary data storage for the ACIA Transmit and Receive Circuits. Both the Transmitter and Receiver are selected by a Register Select 0 (RS0) and Register Select 1 (RS1) low condition. The Read/Write (RWB) line determines which actually uses the internal data bus; the Transmitter Data Register is write only and the Receiver Data Register is read only.

Bit 0 is the first bit to be transmitted from the Transmitter Data Register (least significant bit first). The higher order bits follow in order. Unused bits in this register are "don't care".

The Receiver Data Register holds the first received data bit in bit 0 (least significant bit first). Unused high-order bits are "0". Parity bits are not contained in the Receiver Data Register. They are stripped off after being used for parity checking.



STATUS REGISTER

The Status Register indicates the state of interrupt conditions and other non-interrupt status lines. The interrupt conditions are the Data Set Ready, Data Carrier Detect, Transmitter Data Register Empty and Receiver Data Register Full as reported in bits 6 through 3, respectively. If any of these bits are set the interrupt (IRQ) indicator (bit 7) is also set. Overrun, Framing Error and Parity Error are also reported (bits 2 through 0 respectively).

| | | | | | | | |
|-----|------|------|------|------|------|----|----|
| 7 | 6 | 5 | 4 | 3 | 2 | 1 | 0 |
| IRQ | DSRB | DCDB | TDRE | RDRF | OVRN | FE | PE |

- Bit 7 Interrupt (IRQ)**
 0 No Interrupt
 1 Interrupt has occurred
- Bit 6 Data Set Ready (DSRB)**
 0 DSR low (ready)
 1 DSR high (not ready)
- Bit 5 Data Carrier Detect (DCDB)**
 0 DCD low (detected)
 1 DCD high (not detected)
- Bit 4 Transmitter Data Register Empty**
 0 Not Empty
 1 Empty
- Bit 3 Receiver Data Register Full**
 0 Not full
 1 Full
- Bit 2 Overrun***
 0 No overrun
 1 Overrun has occurred
- Bit 1 Framing Error***
 0 No framing error
 1 Framing error detected
- Bit 0 Parity Error***
 0 No parity error
 1 Parity error detected

*No interrupt occurs for these conditions

Reset Initialization

| | | | | | | | | |
|---|---|---|---|---|---|---|---|----------------|
| 7 | 6 | 5 | 4 | 3 | 2 | 1 | 0 | |
| 0 | - | - | 1 | 0 | 0 | 0 | 0 | Hardware reset |
| - | - | - | - | - | 0 | - | - | Program reset |



STATUS REGISTER BIT DESCRIPTION

Parity error (Bit 0) Framing Error (Bit 1) and Overrun (Bit 2)

None of these bits causes a processor interrupt to occur but, they are normally checked at the time the Receiver Data Register is read so that the validity of the data can be verified. These bits are self clearing (i.e., they are automatically cleared after a read of the Receiver Data Register).

Receiver Data Register Full (Bit 3)

This bit goes to a 1 when the ACIA transfers data from the Receiver Shift Register to the Receiver Data Register and goes to a 0 (is cleared) when the processor reads the Receiver Data Register.

Transmitter Data Register Empty (Bit 4)

This bit goes to a 1 when the ACIA transfers data from the Transmitter Data Register to the Transmitter Shift Register and goes to a 0 (is cleared) when the processor writes new data onto the Transmitter Data Register.

Data Carrier Detect (Bit 5) and Data Set Ready (Bit 6)

These bits reflect the levels of the DCDB and DSRB inputs to the ACIA. A 0 indicates a low level (true condition) and a 1 indicates a high level (false). Whenever either of these inputs change state, an immediate processor interrupt (IRQ) occurs, unless bit 1 of the Command Register (IRD) is set to a 1 to disable IRQB. When the interrupt occurs, the status bits indicate the levels of the inputs immediately after the change of state occurred. Subsequent level changes will not affect the status bits until the Status Register is interrogated by the processor. At that time, another interrupt will immediately occur and the status bits reflect the new input levels. These bits are not automatically cleared (or reset) by an internal operation.

Interrupt (Bit 7)

This bit goes to a 1 whenever an interrupt condition occurs and goes to a 0 (is cleared) when the Status Register is read.



CONTROL REGISTER

The Control Register selects the desired baud rate, frequency source, word length and the number of stop bits.

| | | | | | | | |
|-----|-----|-----|-----|------|------|------|------|
| 7 | 6 | 5 | 4 | 3 | 2 | 1 | 0 |
| SBN | WL | | RCS | SBR | | | |
| | WL1 | WL0 | | SBR3 | SBR2 | SBR1 | SBR0 |

Bit 7 Stop Bit Number (SBN)

| | |
|---|---|
| 0 | 1 Stop bit |
| 1 | 2 Stop bits |
| 1 | 1 ½ Stop bits For WL = 5 and no parity |
| 1 | 1 Stop bit For WL = 8 and parity |

Bits 6-5 Word Length (WL)

| 6 | 5 | No. Bits |
|---|---|----------|
| 0 | 0 | 8 |
| 0 | 1 | 7 |
| 1 | 0 | 6 |
| 1 | 1 | 5 |

Bit 4 Receiver Clock Source (RCS)

| | |
|---|-------------------------|
| 0 | External receiver clock |
| 1 | Baud rate |

Bit 3-0 Selected Baud Rate (SBR)

| 3 | 2 | 1 | 0 | Baud |
|---|---|---|---|--------|
| 0 | 0 | 0 | 0 | 16x |
| 0 | 0 | 0 | 1 | 50 |
| 0 | 0 | 1 | 0 | 75 |
| 0 | 0 | 1 | 1 | 109.92 |
| 0 | 1 | 0 | 0 | 134.58 |
| 0 | 1 | 0 | 1 | 150 |
| 0 | 1 | 1 | 0 | 300 |
| 0 | 1 | 1 | 1 | 600 |
| 1 | 0 | 0 | 0 | 1200 |
| 1 | 0 | 0 | 1 | 1800 |
| 1 | 0 | 1 | 0 | 2400 |
| 1 | 0 | 1 | 1 | 3600 |
| 1 | 1 | 0 | 0 | 4800 |
| 1 | 1 | 0 | 1 | 7200 |
| 1 | 1 | 1 | 0 | 9600 |
| 1 | 1 | 1 | 1 | 19,200 |

Reset Initialization

| | | | | | | | | |
|---|---|---|---|---|---|---|---|-----------------------|
| 7 | 6 | 5 | 4 | 3 | 2 | 1 | 0 | |
| 0 | 0 | 0 | 0 | 0 | 0 | 0 | 0 | Hardware reset (RESB) |
| - | - | - | - | - | - | - | - | Program reset |



CONTROL REGISTER BIT DESCRIPTION

Selected Baud Rate (Bits 0, 1, 2, 3)

These bits select the Transmitter baud rate, which can be at 1/16 an external clock rate or one of 15 other rates controlled by the internal baud rate generator.

If the Receiver clock uses the same baud rate at the transmitter, then RxC becomes an output and can be used to slave other circuits to the ACIA. Figure 3 shows the Transmitter and Receiver layout.

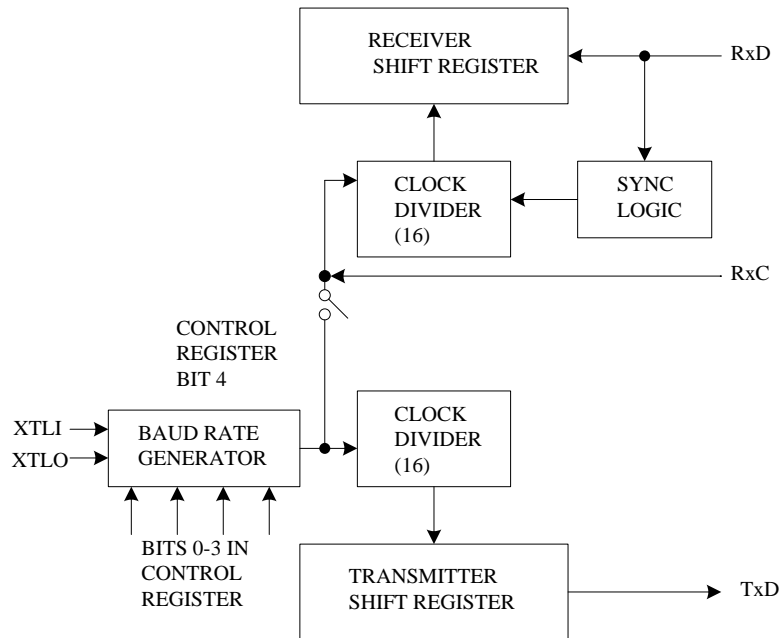

Figure 3 Transmitter/Receiver Clock Circuits

Receiver Clock Source (Bit 4)

This bit controls the clock source to the Receiver. A 0 causes the Receiver to operate at a baud rate of 1/16 an external clock. A 1 causes the Receiver to operate at the same baud rate as is selected for the transmitter.

Word Length (Bits 5, 6)

These bits determine the word length to be used (5, 6, 7 or 8 bits).

Stop Bit Number (Bit 7)

This bit determines the number of stop bits used. A 0 always indicates one stop bit. A 1 indicates 1½ stop bits if the word length is 5 with no parity selected 1 stop bit if the word length is 8 with parity selected and 2 stop bits in all other configurations.



COMMAND REGISTER

The Command Register controls specific modes and functions

| | | | | | | | |
|------|------|-----|-----|------|------|-----|-----|
| 7 | 6 | 5 | 4 | 3 | 2 | 1 | 0 |
| PMC | | PME | REM | TIC | | IRD | DTR |
| PMC1 | PMC0 | | | TIC1 | TIC0 | | |

Bits 7-6 Parity Mode Control (PMC)

| | | |
|----------|----------|--------------------------------|
| <u>7</u> | <u>6</u> | |
| 0 | 0 | Receiver Odd parity checked |
| 0 | 1 | Receiver Even parity checked |
| 1 | 0 | Receiver Parity check disabled |
| 1 | 1 | Receiver Parity check disabled |

Bit 5 Parity Mode Enabled (PME)

| | |
|---|--|
| 0 | Parity mode disabled Parity check and parity transmission disabled |
| 1 | Parity mode enabled and Mark parity bit always transmitted (See Errata, pg. 33) |

Bit 4 Receiver Echo Mode (REM)

| | |
|---|---|
| 0 | Receiver normal mode |
| 1 | Receiver echo mode bits 2 and 3 Must be zero for receiver echo mode, RTS will be low |

Bits 3-2 Transmitter Interrupt Control (TIC)

| | | |
|----------|----------|--|
| <u>3</u> | <u>2</u> | |
| 0 | 0 | RTSB = High, transmit interrupt disabled |
| 0 | 1 | RTSB = Low, transmit interrupt enabled |
| 1 | 0 | RTSB = Low, transmit interrupt disabled |
| 1 | 1 | RTSB = Low, transmit interrupt disabled Transmit break on TxD |

Bit 1 Receiver Interrupt Request Disabled (IRD)

| | |
|---|---------------|
| 0 | IRQB enabled |
| 1 | IRQB disabled |

Bit 0 Data Terminal Ready (DTR)

| | |
|---|-------------------------------------|
| 0 | Data terminal not ready (DTRB high) |
| 1 | Data terminal ready (DTRB low) |

Reset Initialization

| | | | | | | | | |
|---|---|---|---|---|---|---|---|-----------------------|
| 7 | 6 | 5 | 4 | 3 | 2 | 1 | 0 | |
| 0 | 0 | 0 | 0 | 0 | 0 | 0 | 0 | Hardware reset (RESB) |
| - | - | - | 0 | 0 | 0 | 0 | 0 | Program reset |



COMMAND REGISTER BIT DESCRIPTION

Data Terminal Ready (Bit 0)

This bit enables all selected interrupts and controls the state of the Data Terminal Ready (DTRB) line. A 0 indicates the microcomputer system is not ready by setting the DTRB line high. A 1 indicates the microcomputer system is ready by setting the DTRB line low.

Receiver Interrupt Control (Bit 1)

This bit disables the Receiver from generating an interrupt when set to a 1. The Receiver interrupt is enabled when this bit is set to a 0 and Bit 0 is set to a 1.

Transmitter Interrupt Control (Bits 2, 3)

These bits control the state of the Ready to Send (RTSB) line and the Transmitter interrupt.

Receiver Echo Mode (Bit 4)

A 1 enables the Receiver Echo Mode and a 0 enables the Receiver Echo Mode. When bit 4 is a 1 bits 2 and 3 must be 0. In the Receiver Echo Mode, the Transmitter returns each transmission received by the Receiver delayed by one-half bit time.

Parity Mode Enable (Bit 5)

This bit enables parity bit generation and checking. A 0 disables parity bit generation by the Transmitter and parity bit checking by the Receiver. A 1 bit enables generation and checking of parity bits.

Parity Mode Control (Bits 6, 7)

These bits determine the type of parity generated by the Transmitter (W65C51N device currently will only generate a MARK parity bit) and the type of parity check done by the Receiver (even, odd or no check).

INTERFACE SIGNALS

Figure 4 shows the ACIA interface signals associated with the microprocessor and the modem.

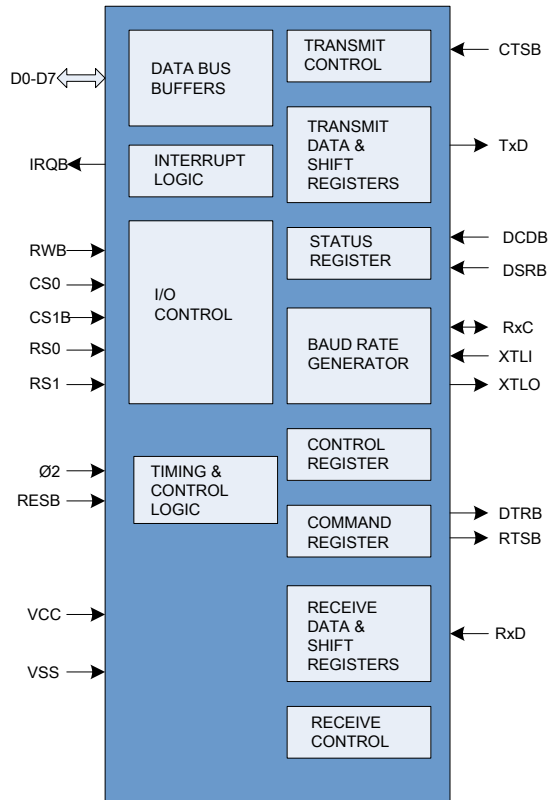

Figure 4 ACIA Interface Diagram

MICROPROCESSOR INTERFACE

Reset (RESB)

During System initialization a low on the RESB input causes a hardware reset to occur. Upon reset, the Command Register and the Control Register are cleared (all bits set to 0). The Status Register is cleared with the exception of the indications of Data Set Ready and Data Carrier Detect, which are externally controlled by the DSRB and DCDB lines, and the transmitter Empty bit, which is set. RESB must be held low for one PHI2 clock cycle for a reset to occur.

Input Clock (PHI2)

The input clock is the system PHI2 clock and clocks all data transfers between the system microprocessor and the ACIA.

Read/Write (RWB)

The RWB input, generated by the microprocessor controls the direction of data transfers. A high on the RWB pin allows the processor to read the data supplied by the ACIA, a low allows a write to the ACIA.

Interrupt Request (IRQB)



The IRQB pin is an interrupt output from the interrupt control logic. It is an open drain output, permitting several devices to be connected to the common IRQB microprocessor input. Normally a high level, IRQB goes low when an interrupt occurs.

Data Bus (D0-D7)

The eight data line (D0-D7) pins transfer data between the processor and the ACIA. These lines are bi-directional and are normally high-impedance except during Read cycles when the ACIA is selected.

Chip Selects (CS0, CS1B)

The two chip select inputs are normally connected to the processor address lines either directly or through decoders. The ACIA is selected when CS0 is high and CS1B is low. When the ACIA is selected, the internal registers are addressed in accordance with the register select lines (RS0, RS1).

Register Selects (RS0, RS1)

The two register select lines are normally connected to the processor address lines to allow the processor to select the various ACIA internal registers. Table 1 shows the internal register select coding.

| RS1 | RS0 | Register Operation | |
|-----|-----|---|-----------------------------|
| | | RWB = Low | RWB = High |
| L | L | Write Transmit Data Register | Read Receiver Data Register |
| L | H | Programmed Reset (Data is "Don't Care") | Read Status Register |
| H | L | Write Command Register | Read Command Register |
| H | H | Write Control Register | Read Control Register |

Table 1 ACIA Register Selection

Only the Command and Control registers can both be read and written. The programmed Reset operation does not cause any data transfer, but is used to clear bits 4 through 0 in the Command Register and bit 2 in the Status Register. The Control Register is unchanged by a programmed Reset. It should be noted that the programmed Reset is slightly different from the hardware Reset (RESB); refer to the register description.



ACIA/MODEM INTERFACE

Crystal Pins (XTLI, XTLO)

These pins are normally directly connected to the external crystal (1.8432 MHz) to derive the various baud rates. Alternatively, an externally generated clock can drive the XTLI pin, in which case the XTLO pin must float. XTLI is the input pin for the transmit clock.

Transmit Data (TxD)

The TxD output line transfers serial non-return-to-zero (NRZ) data to the modem. The least significant bit (LSB) of the Transmit Data Register is the first data bit transmitted and the rate of data transmission is determined by the baud rate selected or under control of an external clock. This selection is made by programming the Control Register.

Receive Data (RxD)

The RxD input line transfers serial NRZ data into the ACIA from the modem, LSB first. The receiver data rate is either the programmed baud rate or under the control of an externally generated receiver clock. The selection is made by programming the Control Register.

Receive Clock (RxC)

The RxC is a bi-directional pin which is either the receiver 16x clock input or the receiver 16x clock output. The latter mode results if the internal baud rate generator is selected for receiver data clocking.

Request to Send (RTSB)

The RTSB output pin controls the modem from the processor. The state of the RTSB pin is determined by the contents of the Command Register.

Clear to Send (CTSB)

The CTSB input pin controls the transmitter operation. The enable state is with CTSB low. The transmitter is automatically disabled if CTSB is high.

Data Terminal Ready (DTRB)

This output pin indicates the status of the ACIA to the modem. A low on DTRB indicates the ACIA is enabled, a high indicates it is disabled. The processor controls this pin via bit 0 of the Command Register.

Data Set Ready (DSRB)

The DSRB input pin indicates to the ACIA the status of the modem. A low indicates the "ready" state and a high, "not-ready"

Data Carrier Detect (DCDB)

The DCDB input pin indicates to the ACIA the status of the carrier-detect output of the modem. A low indicates that the modem carrier signal is present and a high that it is not.

TRANSMITTER AND RECEIVER OPERATION

Continuous Data Transmit

In the normal operating mode, the interrupt request output (IRQB) signals when the ACIA is ready to accept the next data word to be transmitted. This interrupt occurs at the beginning of the Start Bit. When the processor reads the Status Register of the ACIA, the interrupt is cleared.

The processor must then identify that the Transmit Data Register is ready to be loaded and must then load it with the next data word. This must occur before the end of the Stop Bit, otherwise a continuous "MARK" will be transmitted. Figure 5 shows the Continuous Data Transmit timing relationship.

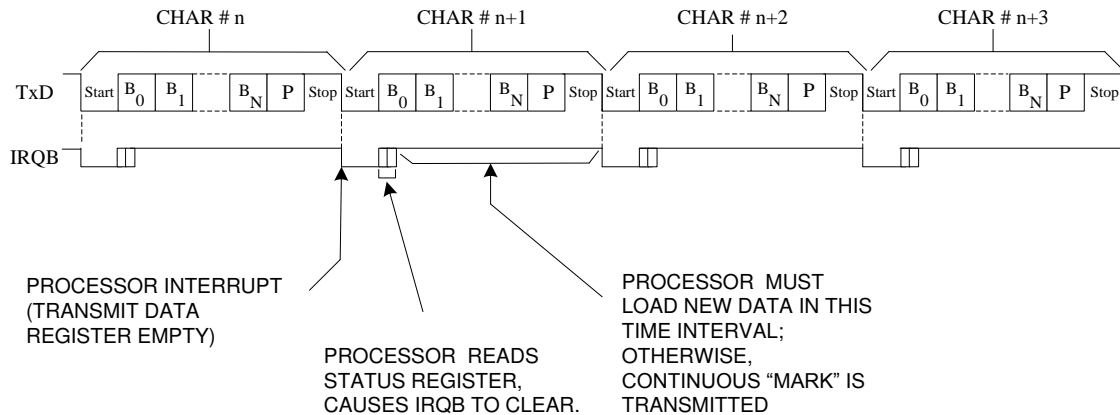

Figure 5 Continuous Data Transmit

Continuous Data Receive

Similar to the Continuous Data Transmit case, the normal operation of this mode is to assert IRQB when the ACIA has received a full data word. This occurs at about the 9/16 point through the Stop Bit. The processor must read the Status Register and read the data word before the next interrupt, otherwise the Overrun condition occurs. Figure 6 shows the continuous Data Receive Timing Relationship.

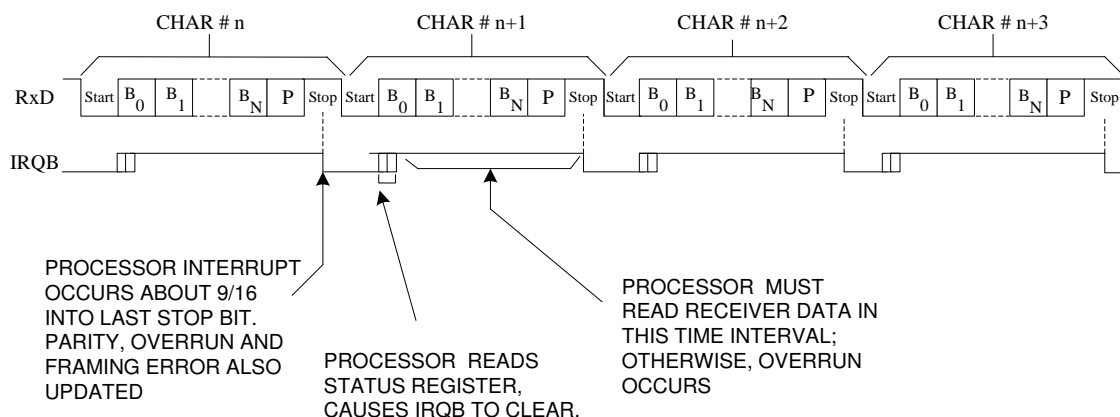

Figure 6 Continuous Data Receive

Transmit Data Register Not Loaded by Processor

If the processor is unable to load the Transmit Data Register in the allocated time, then the TxD line goes to the "MARK" condition until the data is loaded. IRQB interrupts continue to occur at the same rate as previously, yet no data is transmitted. When the processor finally loads new data, a Start Bit immediately occurs, the data word transmission is started and another interrupt is initiated, signaling for the next data word. Figure 7 shows the timing relationship for this mode of operation.

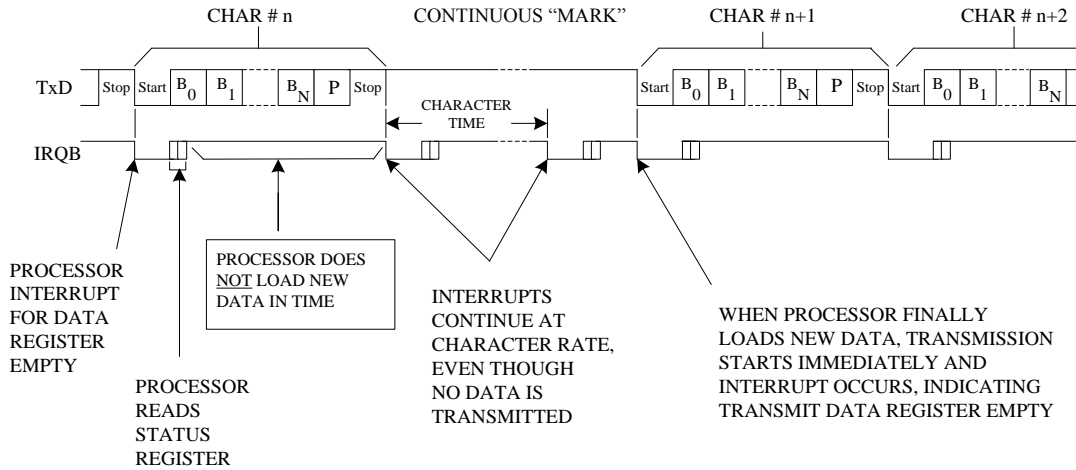

Figure 7 Transmit Data Register Not Loaded by Processor

Effect of CTSB on Transmitter

CTSB is the Clear-to-Send signal generated by the modem. It is normally low (true state) but may go high in the event of some modem problems. When this occurs, the TxD line goes to the "MARK" condition after the entire last character (including parity and stop bit) have been transmitted. Bit 4 in the Status Register indicates that the Transmitter Data Register is not empty and IRQB is *not* asserted. CTSB is transmit control line only, and has not effect on the ACIA Receiver Operation. Figure 8 shows the timing relationship for this mode of operation.

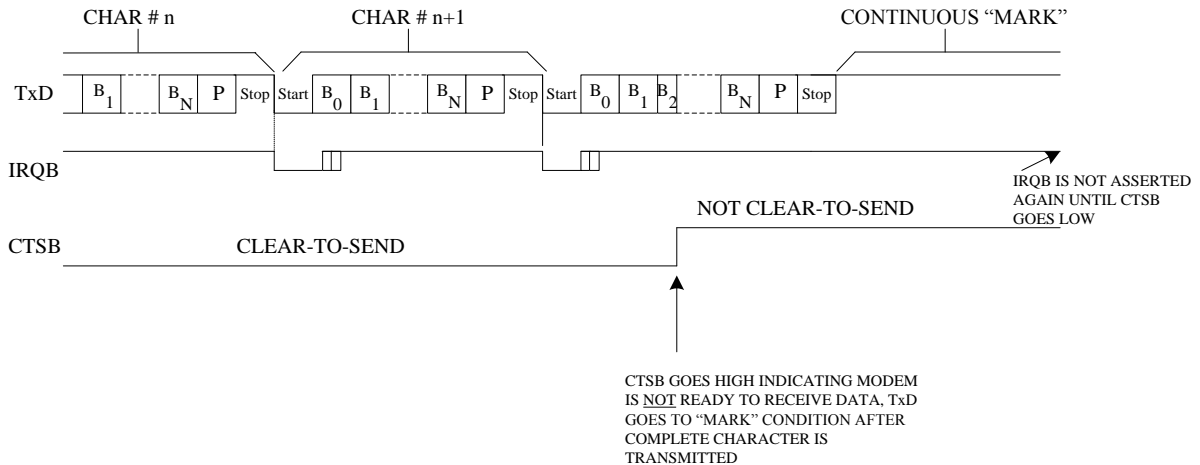

Figure 8 Effect of CTS on Transmitter

Effect of Overrun on Receiver

If the processor does not read the Receiver Data Register in the allocated time, then, when the following interrupt occurs, the new data word is not transferred to the Receiver Data Register, but the Overrun status bit is set. Thus, the Data Register will contain the last valid data word received and all following data is lost. Figure 9 shows the timing relationship for this mode.

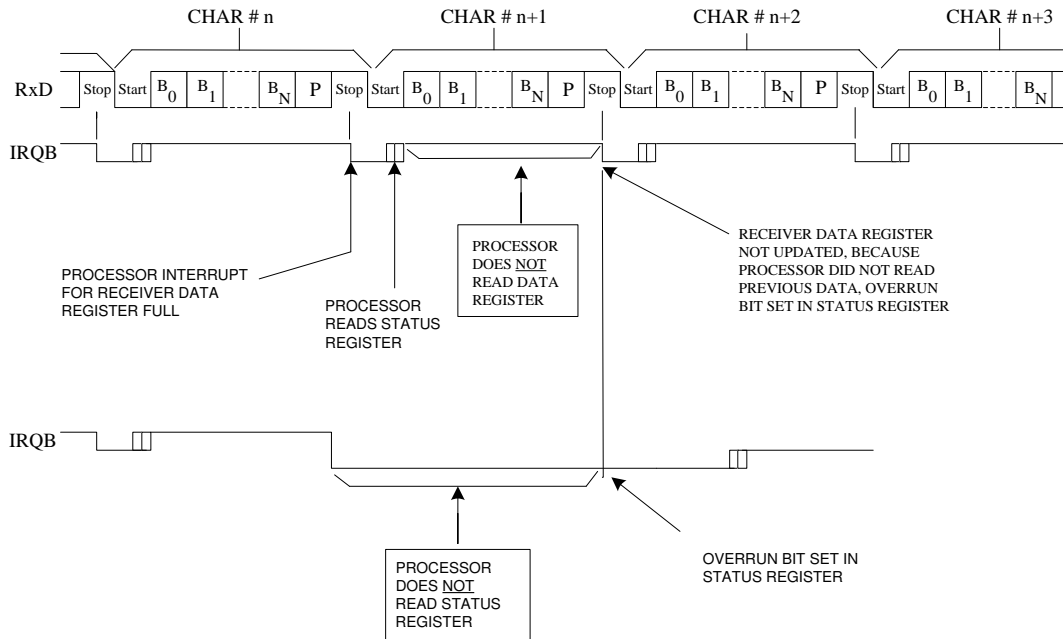

Figure 9 Effect of Overrun on Receiver

Echo Mode Timing

In Echo Mode, the TxD line re-transmits the data on the RxD line, delayed by 1/2 of the bit time, as shown in Figure 10.

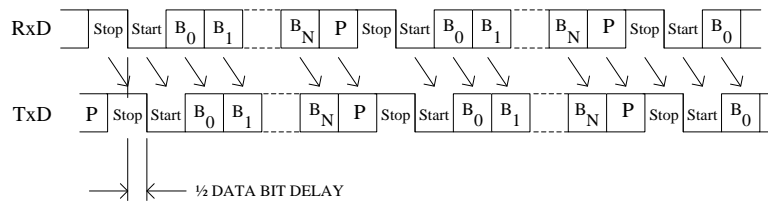

Figure 10 Echo Mode Timing

Effect of CTSB on Echo Mode Operation

In Echo Mode, the Receiver operation is unaffected by CTSB, however, the Transmitter is affected when CTSB goes high, i.e., the TxD line immediately goes to a continuous “Mark” condition. In this case, however, the Status Register indicates that the Receiver Data Register is full in response to an IRQB, so the processor has no way of knowing that the Transmitter has ceased to echo. See Figure 12 for the timing relationship of this mode.

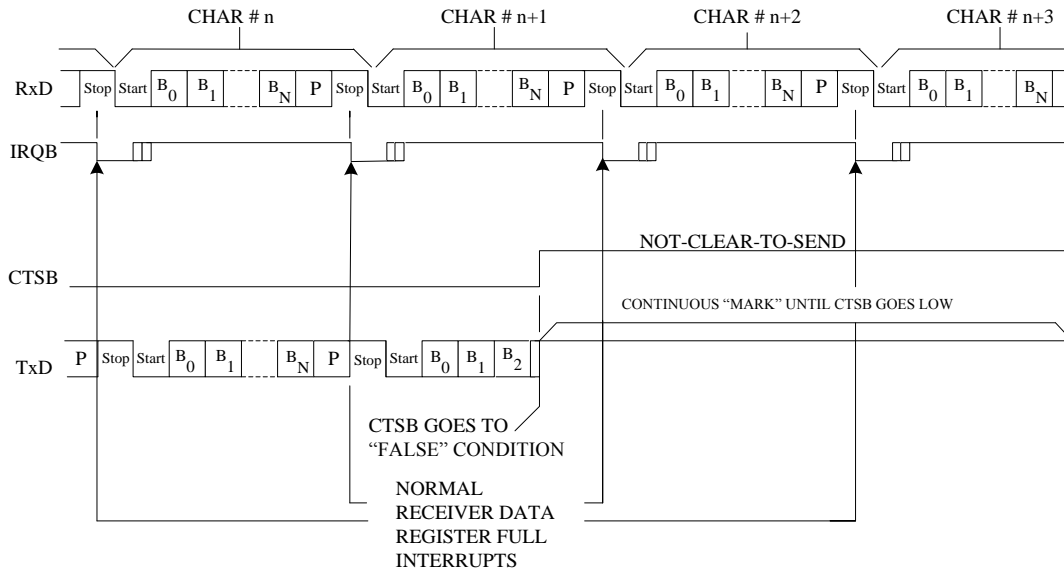

Figure 11 Effect of CTSB on Echo Mode

Overrun in Echo Mode

If Overrun occurs in Echo Mode, the Receiver is affected the same way as a normal overrun in Receive Mode. For the retransmitted data, when overrun occurs, the TxD line goes to the "MARK" condition until the first Start Bit after the Receiver Data Register is read by the processor. Figure 12 shows the timing relationship for this mode.

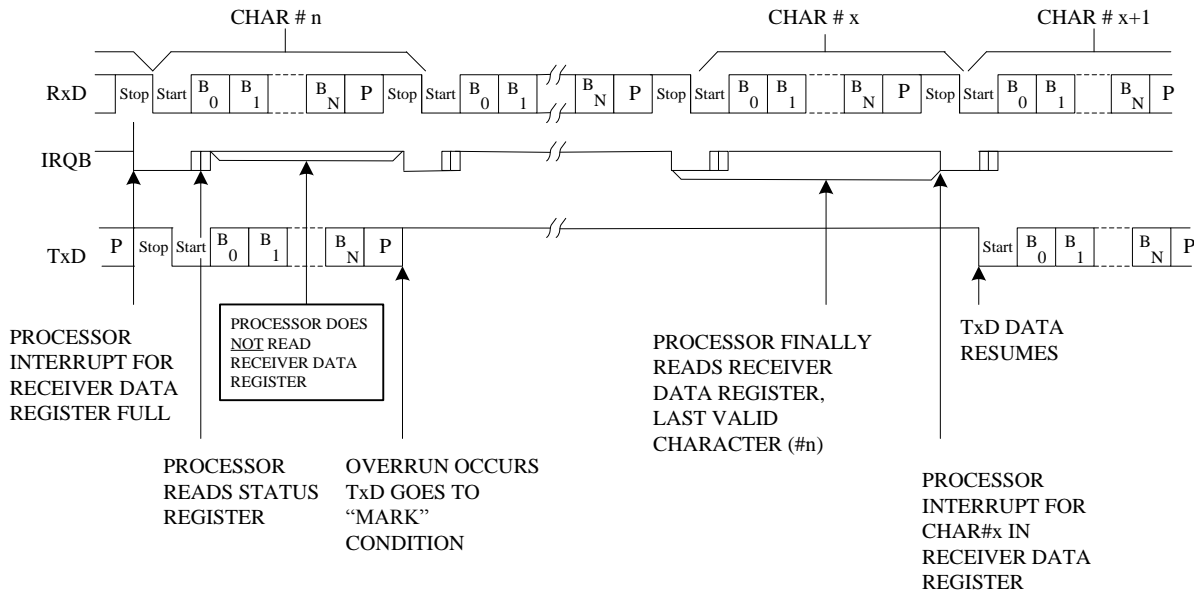

Figure 12 Overrun in Echo Mode

Framing Error

Framing Error is caused by the absence of Stop Bit(s) on received data. A Framing Error is indicated by the setting of bit 1 in the Status Register at the same time the Receiver Data Register Full bit is set, also in the Status Register. In response to IRQB, generated by RDRF, the Status Register can also be checked for the Framing Error. Subsequent data words are tested for Framing Error separately, so the status bit will always reflect the last data word received. See Figure 13 for Framing Error timing relationship.

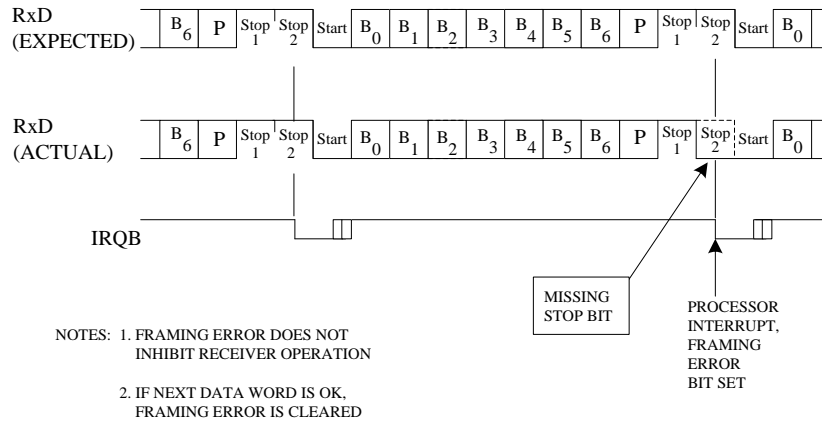

Figure 13 Framing Error

Effect of DCDB on Receiver

DCDB is a modem output indicating the status of the carrier-frequency-detection circuit of the modem. This line goes high for a loss of carrier. Normally, when this occurs, the modem will stop transmitting data some time later. The ACIA asserts IRQB whenever DCDB changes state and indicates this condition via bit 5 in the Status Register.

Once such a change of state occurs, subsequent transitions will not cause interrupts or changes in the Status Register until the first interrupt is serviced. When the Status Register is read by the processor, the ACIA automatically checks the level of the DCDB line, and if it has changed, another IRQB occurs (see Figure 14).

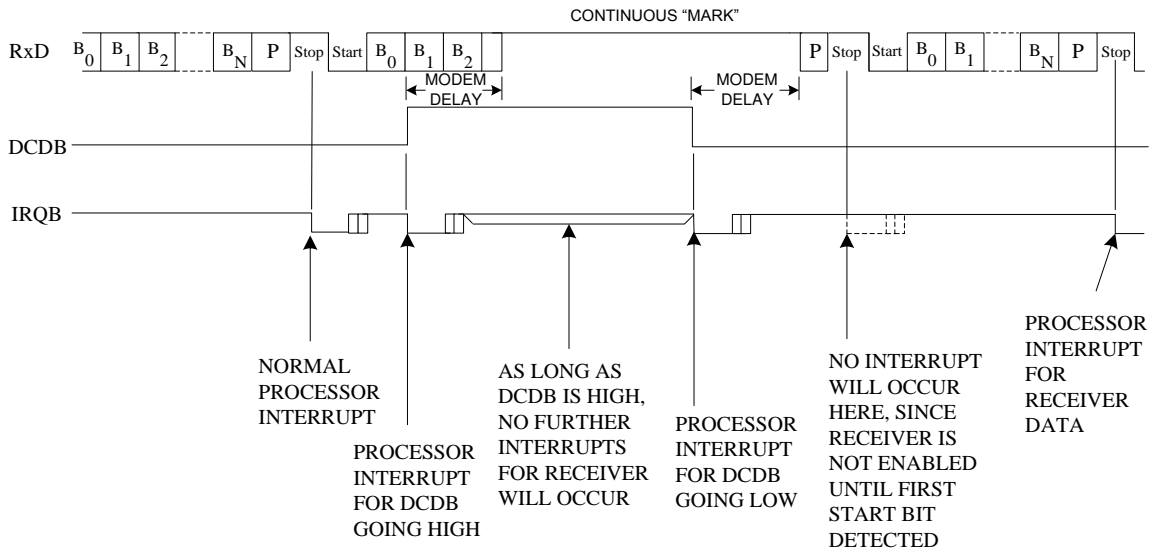

Figure 14 Effect of DCDB on Receiver

Timing with 1½ Stop Bits

It is possible to select 1½ Stop Bits, but this occurs only for 5-bit data words with no parity bit. In this case, the IRQB asserted for Receiver Data Register Full occurs halfway through the trailing half-Stop Bit. Figure 15 shows the timing relationship for this mode.

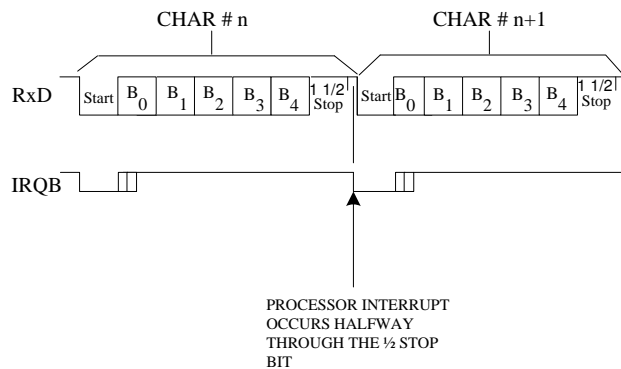

Figure 15 Timing with 1½ Stop Bits

Transmit Continuous “BREAK”

This mode is selected via the ACIA Command Register and causes the Transmitter to send continuous “BREAK” characters, beginning with the next character transmitted. At least one full “BREAK” character will be transmitted, even if the processor quickly reprograms the Command Register transmit mode. Later, when the Command Register is programmed back to normal transmit mode, an immediate Stop Bit will be generated and transmission will resume. Figure 16 shows the timing relationship for this mode.

Note:

If, while operating in the Transmit Continuous “BREAK” mode, the CTSB should go to a high, the TxD will be overridden by the CTSB and will go to continuous “MARK” at the beginning of the next character transmitted after the CTSB goes high.

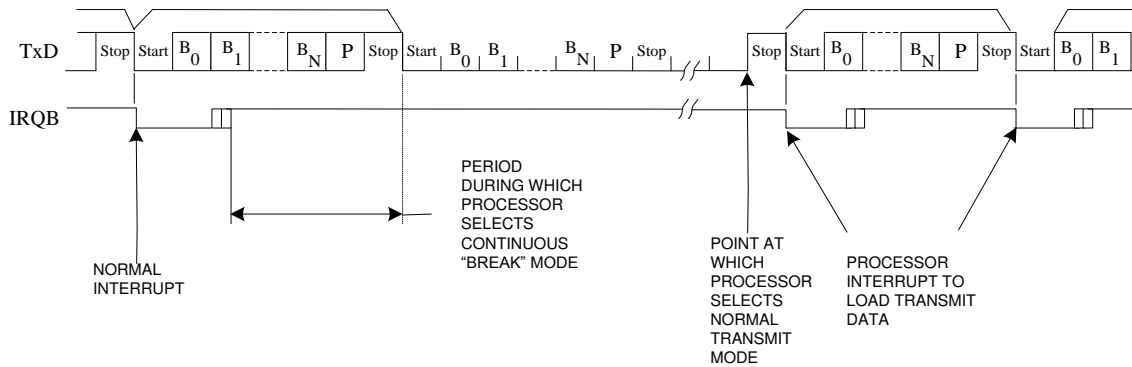

Figure 16 Transmit Continuous “BREAK”

Receive Continuous “BREAK”

In the event the modem transmits continuous “BREAK” characters, the ACIA will terminate receiving. Reception will resume only after a Stop Bit is encountered by the ACIA. Figure 17 shows the timing relationship for continuous “BREAK” characters.

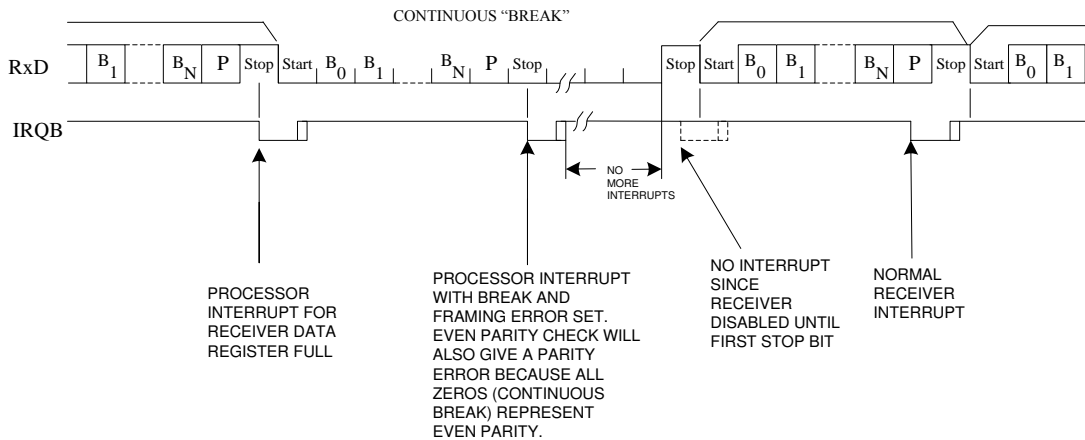

Figure 17 Receive Continuous “BREAK”



STATUS REGISTER OPERATION

Because of the special functions of the various status bits, there is a suggested sequence for checking them. When an interrupt occurs, the ACIA should be interrogated as follows:

1. Read Status Register

This operation automatically clears Bit 7 (IRQB). Subsequent transitions on DSRB and DCDB will cause another interrupt.

2. Check IRQB (Bit 7) in the data read from the Status Register.

If not set, the interrupt source is not the ACIA.

3. Check DCDB and DSRB

These must be compared to their previous levels, which must have been saved by the processor. If they are both 0 (modem "on-line") and they are unchanged then the remaining bits must be checked.

4. Check RDRF (Bit 3)

Check for Receiver Data Register Full.

5. Check Parity, Overrun and Framing Error (Bits 0-2) if the Receiver Data Register is full.

6. Check TDRE (Bit 4)

Check for Transmitter Data Register Empty.

7. If none of the above conditions exist, then CTSB must have gone to the false (high) state.

PROGRAM RESET OPERATION

A program reset occurs when the processor performs a write operation to the ACIA with RS0 low and RS1 high. The program reset operates somewhat different from the hardware reset (RESB pin) and is described as follows:

1. Internal registers are not completely cleared. Check register formats for the effect of a program reset on internal registers

2. The DTRB line goes high immediately.

3 Receiver and transmitter interrupts are disabled immediately. If IRQB is low when the reset occurs, it stays low until serviced, unless interrupt was caused by DCDB or DSRB transition.

4. DCDB and DSRB interrupts are disabled immediately. If IRQB is low and was caused by DCDB or DSRB, then it goes high, also DCDB and DSRB status bits subsequently will follow the input lines, although no interrupt will occur.

5. Overrun cleared, if set.

MISCELLANEOUS

1. If Echo Mode is selected, RTSB goes low.

2. If Bit 0 of Command Register is 0 (disabled) then:

- a) All interrupts are disabled including those caused by DCDB and DSRB transitions.

- b) Transmitter is disabled immediately.

- c) Receiver is disabled, but a character currently being received will be completed first.

3. Odd parity occurs when the sum of all the 1 bits in the data word (including the parity bit) is odd.

4. In the receive mode, the received parity bit does not go into the Receiver Data Register, but generates parity error or no parity error for the Status Register.

5. Transmitter and Receiver may be in full operation simultaneously. This is "full-duplex" mode.

6. If the RxD line inadvertently goes low and then high right after a Stop Bit, the ACIA does not interpret this as a Start Bit, but samples the line again halfway into the bit to determine if it is a true Start Bit or a false one. For false Start Bit detection, the ACIA does not begin to receive data, instead, only a true Start Bit initiates receiver operation.



7. Precautions to consider with the crystal oscillator circuit:
 - a) The external crystal should be a "series" mode crystal.
 - b) The XTLI input may be used as an external clock input. The unused pin (XTLO) must be floating and may not be used for any other function.
8. DCDB and DSRB transitions, although causing immediate processor interrupts, have no affect on transmitter operation. Data will continue to be sent, unless the processor forces transmitter to turn off. Since these are high-impedance inputs, they must not be permitted to float (un-connected). If unused, they must be terminated either to GND or VCC.

GENERATION OF NON-STANDARD BAUD RATES

Divisors

The internal counter/divider circuit selects the appropriate divisor for the crystal frequency by means of bits 0-3 of the ACIA Control Register, as shown in Table 2.

Generating Other Baud Rates

By using a different crystal, other baud rates may be generated. These can be determined by:

$$\text{Baud Rate} = \frac{\text{Crystal Frequency}}{\text{Divisor}}$$

Furthermore, it is possible to drive the ACIA with an off-chip oscillator to achieve other baud rates. In this case, XTLI (Pin 6) must be the clock input and XTLO (pin 7) must be a no-connect.



Table 2 Divisor Selection

| Control Register Bits | Divisor Selected for the Internal Counter | Baud Rate Generated With 1.8432MHz Crystal | Baud Rate Generated With a Crystal of Frequency (F) |
|-----------------------|---|--|---|
| 3 2 1 0 | | | |
| 0 0 0 0 | No Divisor Selected | 16 x External Clock at Pin RxC | 16 x External Clock at Pin RxC |
| 0 0 0 1 | 36,864 | $\frac{1.8432 \times 10^6}{36,864} = 50$ | $\frac{F}{36,864}$ |
| 0 0 1 0 | 24,576 | $\frac{1.8432 \times 10^6}{24,576} = 75$ | $\frac{F}{24,576}$ |
| 0 0 1 1 | 16,769 | $\frac{1.8432 \times 10^6}{16,769} = 109.92$ | $\frac{F}{16,769}$ |
| 0 1 0 0 | 13,704 | $\frac{1.8432 \times 10^6}{13,704} = 134.51$ | $\frac{F}{13,704}$ |
| 0 1 0 1 | 12,288 | $\frac{1.8432 \times 10^6}{12,288} = 150$ | $\frac{F}{12,288}$ |
| 0 1 1 0 | 6,144 | $\frac{1.8432 \times 10^6}{6,144} = 300$ | $\frac{F}{6,144}$ |
| 0 1 1 1 | 3,072 | $\frac{1.8432 \times 10^6}{3,072} = 600$ | $\frac{F}{3,072}$ |
| 1 0 0 0 | 1,536 | $\frac{1.8432 \times 10^6}{1,536} = 1,200$ | $\frac{F}{1,536}$ |
| 1 0 0 1 | 1,024 | $\frac{1.8432 \times 10^6}{1,024} = 1,800$ | $\frac{F}{1,024}$ |
| 1 0 1 0 | 768 | $\frac{1.8432 \times 10^6}{768} = 2,400$ | $\frac{F}{768}$ |
| 1 0 1 1 | 512 | $\frac{1.8432 \times 10^6}{512} = 3,600$ | $\frac{F}{512}$ |
| 1 1 0 0 | 384 | $\frac{1.8432 \times 10^6}{384} = 4,800$ | $\frac{F}{384}$ |
| 1 1 0 1 | 256 | $\frac{1.8432 \times 10^6}{256} = 7,200$ | $\frac{F}{256}$ |
| 1 1 1 0 | 192 | $\frac{1.8432 \times 10^6}{192} = 9,600$ | $\frac{F}{192}$ |
| 1 1 1 1 | 96 | $\frac{1.8432 \times 10^6}{96} = 19,200$ | $\frac{F}{96}$ |



DIAGNOSTIC LOOP-BACK OPERATING MODES

A simplified block diagram for a system incorporating an ACIA is shown in Figure 18.

It may be desirable to include in the system a facility for "loop-back" testing, of which there are two kinds.

1. Local Loop-Back
Loop-back from the point of view of the processor. In this case, the Modem and Data Link must be effectively disconnected and the ACIA transmitter connected back to its own receiver, so that the processor can perform diagnostic checks on the system, excluding the actual data channel.
2. Remote Loop-back
Loop-back from the point of view of the Data Link and Modem. In this case, the processor, itself, is disconnected and all received data is immediately retransmitted, so the system on the other end of the Data Link may operate independent of the local system.

The ACIA does not contain automatic loop-back operating modes, but they may be implemented with the addition of a small amount of external circuitry. Figure 19 indicates the necessary logic to be used with the ACIA. The LBB line is the positive-true signal to enable local loop-back operation. Essentially, LLB = high does the following:

1. Disables outputs TxD, DTRB and RTSB (to Modem)
2. Disables inputs RxD, DCDB, CTSB, DSRB (from Modem)
3. Connects transmitter outputs to respective receiver inputs (i.e., TxD to RxD, DTRB to DCDB, RTSB to CTSB).

LLB may be tied to a peripheral control pin (from a W65C21 or W65C22S₁ for example) to provide processor control of local loop-back operation. In this way, the processor can easily perform local loop-back diagnostic testing.

Remote loop-back does not require this circuitry, so LLB must be set low. However, the processor must select the following:

1. Control Register bit 4 must be 1, so that the transmitter clock equals the receiver clock.
2. Command Register bit 4 must be 1 to select Echo Mode.
3. Command Register bits 3 and 2 must be 1 and 0, respectively to disable IRQB interrupt to transmitter.
4. Command Register bit 1 must be 0 to disable IRQB interrupt for receiver.

In this way, the system re-transmits received data without any effect on the local system.

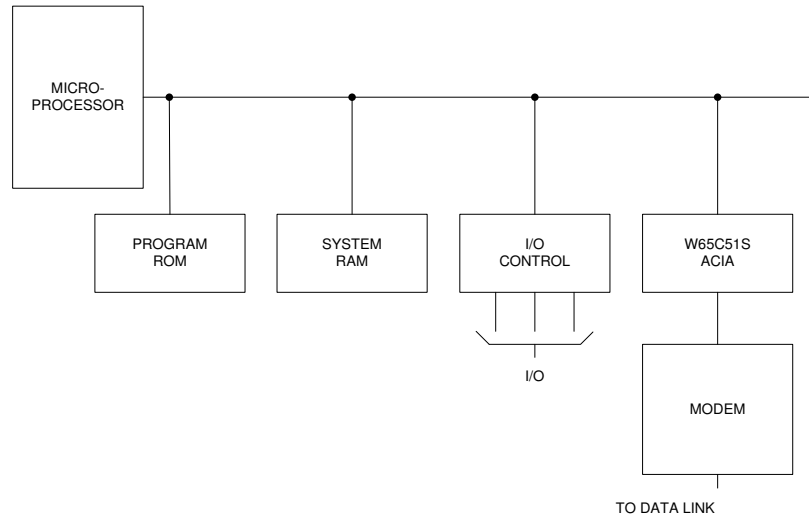

Figure 18 Simplified System Diagram

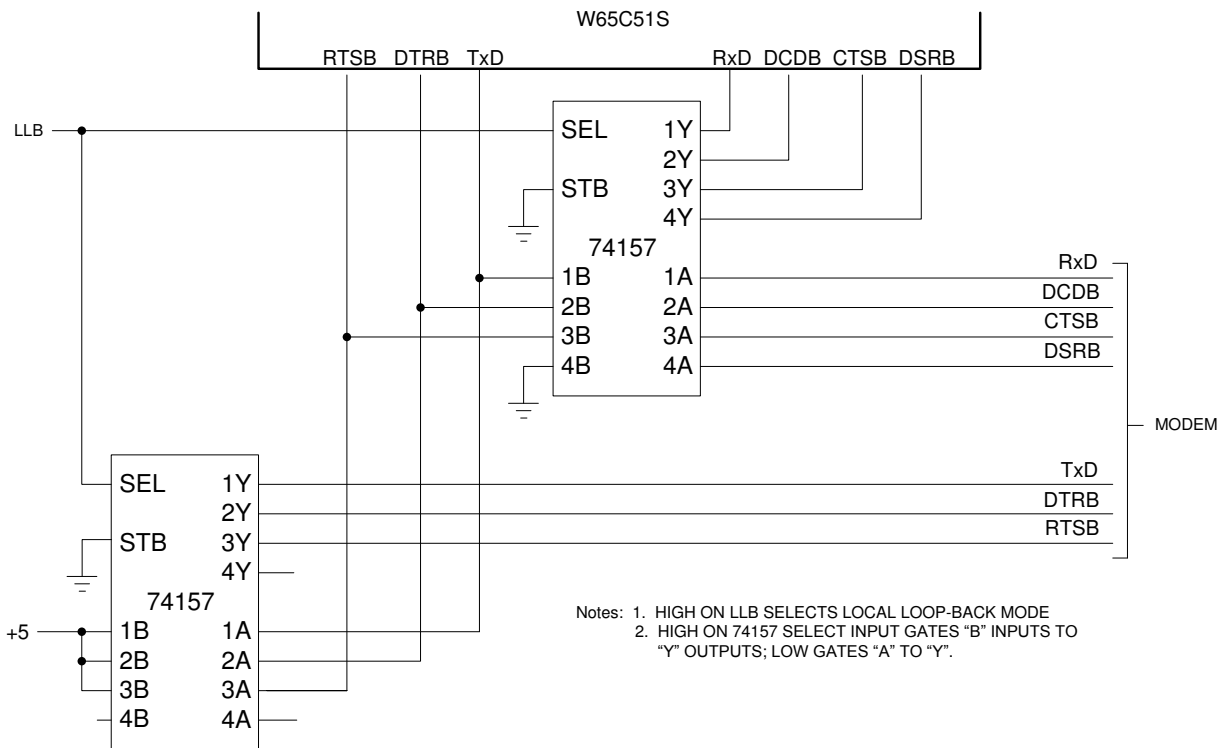

Figure 19 Loop-Back Circuit Schematic

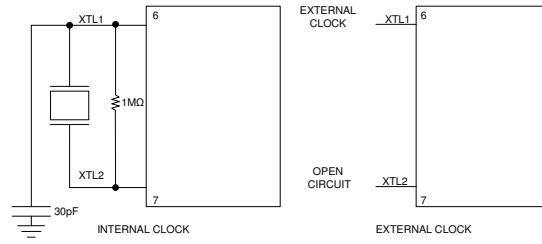

Figure 20 Clock Generation W65C51N



READ TIMING DIAGRAM

Timing diagrams for transmit with external clock, receive with external clock and IRQB generation are shown in Figures 21, 22 and 23 respectively. The corresponding timing characteristics are listed in Table 3.

Table 2 Transmit/Receive Characteristics

| Characteristic | Symbol | 1 MHz | | 2 MHz | | Unit |
|---|------------------|-------|-----|-------|-----|------|
| | | Min | Max | Min | Max | |
| Transmit/Receive Clock Rate | t _{CCY} | 400* | - | 400* | - | nS |
| Transmit/Receive Clock High Time | t _{CH} | 175 | - | 175 | - | nS |
| Transmit/Receive Clock Low Time | t _{CL} | 175 | - | 175 | - | nS |
| XTL1 to TxD Propagation Delay | t _{DD} | - | 500 | - | 500 | nS |
| RTS Propagation Delay | t _{DLY} | - | 500 | - | 500 | nS |
| IRQB Propagation Delay (Clear) | t _{IRQ} | - | 500 | - | 500 | nS |
| Notes: | | | | | | |
| 1. (t _R , t _F = 10 to 30 nS) | | | | | | |
| *The baud rate with external clocking is: Baud Rate = $\frac{1}{16 \times t_{CCY}}$ | | | | | | |

Test and Crystal Specifications

1. Temperature stability ± 0.01% (-40° C to +85° C)
2. Characteristics at 25° C ± 2° C
 - a. Frequency (MHz) 1.8432
 - b. Frequency tolerance (± %) 0.02
 - c. Resonance mode Series
 - d. Equivalent resistance (ohm) 400 max.
 - e. Drive level (mW) 2
 - f. Shunt capacitance (pF) 7 max.
 - g. Oscillation mode Fundamental

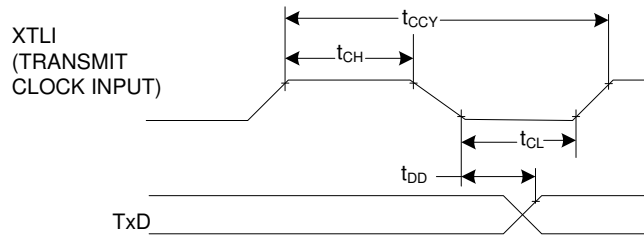

NOTE: TxD RATE IS 1/16 TxC RATE

Figure 21 Transmit Timing with External Clock

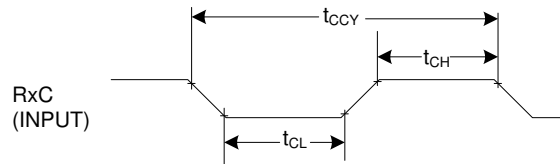

NOTE: RxD RATE IS 1/16 RxC RATE

Figure 22 Receive External Clock Timing

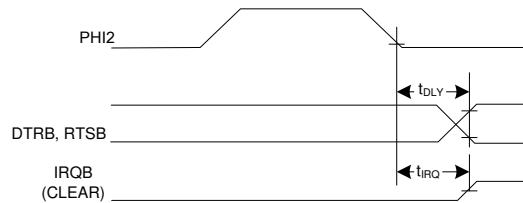

Figure 23 Interrupt and Output Timing

Table 3 AC Characteristics

| Parameter | Symbol | 2 MHz | | 4 MHz | | Units |
|--------------------------------|-----------|-------|-----|-------|-----|-------|
| | | Min | Max | Min | Max | |
| PHI2 Cycle Time | t_{CYC} | 500 | - | 250 | - | nS |
| PHI2 Pulse Width | t_C | 200 | - | 100 | - | nS |
| Address Set-Up Time | t_{AC} | 60 | - | 30 | - | nS |
| Address Hold Time | t_{CAH} | 0 | - | 0 | - | nS |
| RWB Set-Up Time | t_{WC} | 60 | - | 30 | - | nS |
| RWB Hold Time | t_{CWH} | 0 | - | 0 | - | nS |
| Data Bus Set-Up time | t_{DCW} | 60 | - | 35 | - | nS |
| Data Bus Hold Time | t_{HW} | 10 | - | 5 | - | nS |
| Read Access Time (Valid Data) | t_{CDR} | - | 150 | - | 50 | nS |
| Read Hold Time | t_{HR} | 10 | - | 10 | - | nS |
| Bus Active Time (Invalid Data) | t_{CDA} | 20 | - | 10 | - | nS |

Notes:
 1. $V_{CC} = 5.0V \pm 5\%$
 2. $T_A = T_L$ to T_H
 3. t_R and $t_F = 10$ to 30 nSs.

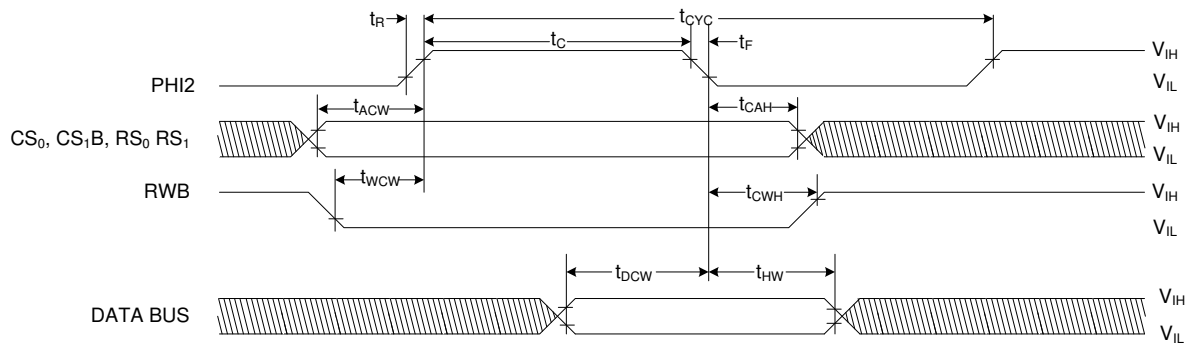

Figure 24 Write Timing Diagram

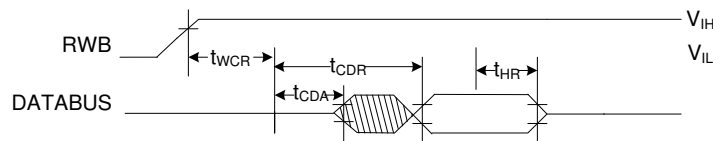

Figure 25 Read Timing Characteristics



ABSOLUTE MAXIMUM RATINGS*

| Parameter | Symbol | Value | Unit |
|---|------------------|-------------------------------|------|
| Supply Voltage | V _{CC} | -0.3 to +7.0V | Vdc |
| Input Voltage | V _{IN} | -0.3 to V _{CC} +0.3 | Vdc |
| Output Voltage | V _{OUT} | -0.3 to V _{CC} +0.3V | Vdc |
| Operating Temp. Commercial Industrial | T _A | 0 to +70 -40 to +85 | °C |
| Storage Temp. | T _{STG} | -55 to +150 | °C |

OPERATING CONDITIONS

| Parameter | Symbol | Value |
|---|-----------------|------------------------------|
| Supply Voltage | V _{CC} | 5V ± 5% |
| Operating Temp. Commercial Industrial | T _A | 0 to +70°C -40°C to +85°C |

* NOTE: Stresses above those listed may cause permanent damage to the device. This is a stress rating only and functional operation of the device at these or any other conditions above those indicated in other sections of this document is not implied. Exposure to absolute maximum rating conditions for extended periods may affect device reliability.

DC CHARACTERISTICS

(V_{CC} = 5.0V ± 5%, V_{SS} = 0, T_A = T_L to T_H, unless otherwise noted)

| Parameter | Symbol | Min | Typ | Max | Unit | Test Conditions |
|--|-------------------------------------|------|------|-----------------|----------|---|
| Input High Voltage | V _{IH} | 2.0 | -- | V _{CC} | V | |
| Input Low Voltage | V _{IL} | -0.3 | -- | +0.8 | V | |
| Input Leakage Current CS0, CS1B, CT5B, DCDB, DSRB, PHI2, RESB, RS0, RS1, RWB, RxD | I _{IN} | -- | ±1 | ±2.5 | µA | V _{IN} = 0V to V _{CC} V _{CC} = 5.25V |
| Leakage Current (Three State Off) D0-D7 | I _{TSI} | -- | ±2 | ±10 | µA | V _{IN} = 0.4V to 2.4V V _{CC} = 5.25V |
| Output High Voltage D0-D7, DTRB, RTSB, RxC, TxD | V _{OH} | 2.4 | -- | -- | V | V _{CC} = 4.75V I _{LOAD} = -100 µA |
| Output Low Voltage D0-D7, DTRB, IRQB, RTSB, RxC, TxD, | V _{OL} | -- | -- | 0.4 | V | V _{CC} = 4.75V I _{LOAD} = 1.6 mA |
| Output High Current (Sourcing) D0-D7, DTRB, RTSB, RxC, TxD | I _{OH} | -200 | -400 | -- | µA | V _{OH} = 2.4V |
| Output Low Current (Sinking) D0-D7, DTRB, IRQB, RTSB, RxC, TxD, | I _{OL} | 1.6 | -- | -- | mA | V _{OL} = 0.4V |
| Output Leakage Current (off state): IRQB | I _{OFF} | -- | | 10 | µA | V _{OUT} = 5.0V |
| Power Dissipation | P _D | -- | 7 | 10 | mW/MHz | |
| Input Capacitance All except PHI2 PHI2 | C _{CLK} C _{IN} | -- | | 20 10 | pF pF | V _{CC} = 5.0V V _{IN} = 0V f = 2 MHz T _A = 25° C |
| Output Capacitance | C _{OUT} | -- | | 10 | pF | |

Notes:
 1. All units are direct current (dc) except for capacitance.
 2. Negative sign indicates outward current flow, positive indicates inward flow.
 3. Typical values are shown for V_{CC} = 5.0V and T_A = 25° C

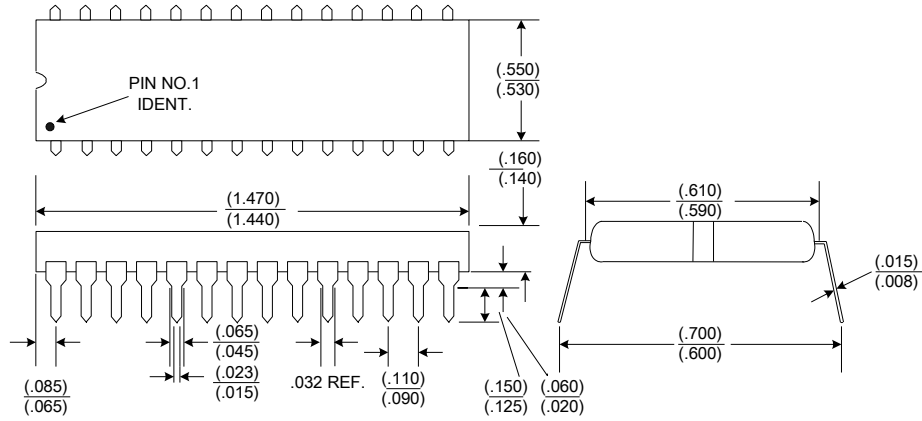
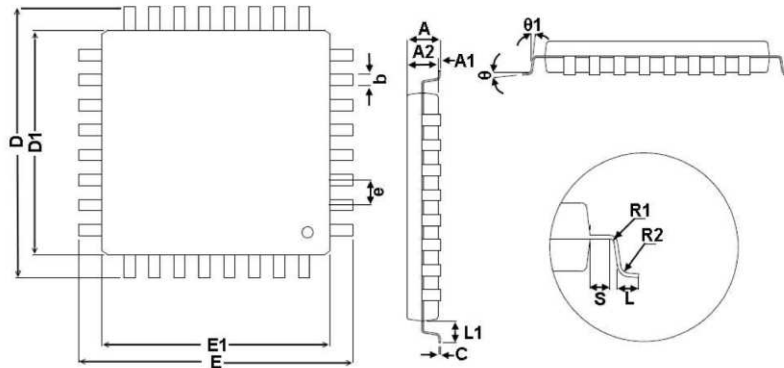

Figure 26 28 Pin Plastic Dip Package Dimensions



| SYMBOL | MILLIMETER | | |
|------------|------------|----------|------|
| | MIN. | NOM. | MAX. |
| A | — | — | 1.60 |
| A1 | 0.05 | — | 0.15 |
| A2 | 1.35 | 1.40 | 1.45 |
| D | — | 9.00 BSC | — |
| D1 | — | 7.00 BSC | — |
| E | — | 9.00 BSC | — |
| E1 | — | 7.00 BSC | — |
| θ | 0° | 3.5° | 7° |
| $\theta 1$ | 0° | — | — |
| S | 0.20 | — | — |
| R1 | 0.08 | — | — |
| R2 | 0.08 | — | 0.20 |
| L | 0.45 | 0.60 | 0.75 |
| L1 | — | 1.00 REF | — |
| b | 0.30 | — | 0.45 |
| e | — | 0.80 BSC | — |
| c | 0.09 | — | 0.20 |

Figure 27 32 Pin Low-Profile Quad Flat Pack (LQFP) Package Dimensions



W65C51N6TPG-14 Samples Errata Sheet for Date Code:
1002G002

The current engineering sample is provided in a 28 pin PDIP package. This information below describes the current known errors and improvements with the current W65C51N ACIA Engineering Samples found by WDC. Please contact WDC with any other errors found while evaluating these samples.

Known Issues with Current Engineering Sample (Date Code: 1002G002)

Transmitter Parity:

The transmitter of this part functions differently than previous 6551/65C51 devices. For all Parity Mode Control (PMC) settings (Bits 7, 6 of the Command Register), the transmitter will transmit a MARK (1) for Parity (When enabled with Bit 5 of the Command Register set to "1"). Previous versions would transmit Even, Odd, Mark or Space parity depending on the PMC bits.



ORDERING INFORMATION

| W65C51N6TPG-14 | |
|--|------|
| Description W65C = standard product | W65C |
| Product Identification Number | 51N |
| Foundry Process 6T = 0.6u TSMC Process | 6T |
| Package P = Plastic Dual-In-Line, 28 pins | P |
| RoHS/Green Compliance G = RoHS/Green Compliant (Wafer and Packaging) | G |
| Speed Designator -14 = 14MHz | -14 |

To receive general sales or technical support on standard product or information about our module library licenses, contact us at:

The Western Design Center, Inc.
 2166 East Brown Road
 Mesa, Arizona 85213 USA
 Phone: 480-962-4545 Fax: 480-835-6442
 e-mail: Info@WesternDesignCenter.com
www.WesternDesignCenter.com

WARNING: MOS CIRCUITS ARE SUBJECT TO DAMAGE FROM STATIC ELECTRICAL CHARGE BUILDUPS. Industry established recommendations for handling MOS circuits include:

1. Ship and store product in conductive shipping tubes or conductive foam plastic. Never ship or store product in non-conductive plastic containers or non-conductive plastic foam material.
2. Handle MOS parts only at conductive workstations.
3. Ground all assembly and repair tools.