



65xx

**W65C22
(W65C22N and W65C22S)
Versatile Interface Adapter (VIA)
Datasheet**



WDC reserves the right to make changes at any time without notice in order to improve design and supply the best possible product. Information contained herein is provided gratuitously and without liability, to any user. Reasonable efforts have been made to verify the accuracy of the information but no guarantee whatsoever is given as to the accuracy or as to its applicability to particular uses. In every instance, it must be the responsibility of the user to determine the suitability of the products for each application. WDC products are not authorized for use as critical components in life support devices or systems. Nothing contained herein shall be construed as a recommendation to use any product in violation of existing patents or other rights of third parties. The sale of any WDC product is subject to all WDC Terms and Conditions of Sales and Sales Policies, copies of which are available upon request.

Copyright ©1981-2010 by The Western Design Center, Inc. All rights reserved, including the right of reproduction, in whole or in part, in any form.



TABLE OF CONTENTS

1. INTRODUCTION.....	7
2. W65C22 FUNCTION DESCRIPTION	8
2.1 Peripheral Data Ports	8
2.2 Data Transfer - Handshake Control	10
2.3 Read Handshake Control.....	11
2.4 Write Handshake Control.....	12
2.5 Timer 1 Operation	14
2.6 Timer 1 One-Shot Mode	17
2.7 Timer 1 Free-Run Mode.....	18
2.8 Timer 2 Operation	19
2.9 Timer 2 One-Shot Mode	19
2.10 Timer 2 Pulse Counting Mode	20
2.11 Shift Register Operation	20
2.12 Shift Register Input Modes	21
2.12.1 Shift Register Disabled (000).....	21
2.12.2 Shift In - Counter T2 Control (001).....	22
2.12.3 Shift In - PHI2 Clock Control (010).....	22
2.12.4 Shift In - External CB1 Clock Control (011)	23
2.13 Shift Register Output Modes	23
2.13.1 Shift Out - Free Running at T2 Rate (100).....	23
2.13.2 Shift Out - T2 Control (101).....	24
2.13.3 Shift Out - PHI2 Clock Control (110).....	24
2.13.4 Shift Out - External CB1 Clock Control (111)	25
2.14 Interrupt Operation	25
3. PIN FUNCTION DESCRIPTION	28
3.1 Peripheral Data Port A Control Lines (CA1, CA2)	30
3.2 Peripheral Data Port B Control Lines (CB1, CB2)	30
3.3 Chip Select (CS1, CS2B)	30
3.4 Data Bus (D0-D7)	31
3.5 Interrupt Request (IRQB)	31
3.6 Peripheral Data Port A (PA0-PA7).....	32
3.7 Peripheral Data Port B (PB0-PB7).....	34
3.8 Phase 2 Internal Clock (PHI2).....	36
3.9 Reset (RESB).....	36
3.10 Register Select (RS0-RS3)	36
3.11 RWB (Read/Write)	36
3.12 VDD and VSS.....	36



4. TIMING, AC AND DC CHARACTERISTICS 37

4.1 W65C22 Absolute Maximum Ratings 37

4.2 DC Characteristics TA= -40°C to +85°C 38

4.3 AC Characteristic TA=-40°C to +85°C 42

4.4 Timing Diagrams..... 46

5. CAVEATS..... 50

5.1 Older Versions 50

5.2 Shift Clock 50

5.3 Bus Holding Pins 50

5.4 Current Limiting..... 50

6. HARD CORE MODEL 51

6.1 W65C22C vs. W65C22S..... 51

6.2 Chip Select 51

6.3 W65C22C and W65C22S Timing 51

7. ORDERING INFORMATION..... 52



Table of Figures

FIGURE 1-1 W65C22 INTERNAL ARCHITECTURE BLOCK DIAGRAM.....	7
FIGURE 2-1 READ HANDSHAKE OPERATION (PA ONLY)	11
FIGURE 2-2 WRITE HANDSHAKE (PA AND PB).....	12
FIGURE 3-1 W65C22 40 PIN PDIP PINOUT	28
FIGURE 3-2 W65C22 44 PIN PLCC PINOUT	28
FIGURE 3-2 W65C22 44 PIN QFP PINOUT	29
FIGURE 3-3 W65C22N AND GTE - G65SC22 CMOS PORT A BUFFER (PA0-PA7, CA2)	32
FIGURE 4-1 READ TIMING	46
FIGURE 4-2 WRITE TIMING.....	46
FIGURE 4-3 READ HANDSHAKE, PULSE MODE (CA2)	47
FIGURE 4-4 READ HANDSHAKE, HANDSHAKE MODE TIMING (CA2)	47
FIGURE 4-5 WRITE HANDSHAKE, PULSE MODE TIMING (CA2, CB2)	47
FIGURE 4-6 WRITE HANDSHAKE, HANDSHAKE MODE TIMING (CA2, CB2).....	48
FIGURE 4-7 PERIPHERAL DATA, INPUT LATCHING TIMING	48
FIGURE 4-8 DATA SHIFT OUT, INTERNAL OR EXTERNAL SHIFT CLOCK TIMING.....	48
FIGURE 4-9 DATA SHIFT IN, INTERNAL OR EXTERNAL SHIFT CLOCK TIMING.....	49
FIGURE 4-10 EXTERNAL SHIFT CLOCK TIMING.....	49
FIGURE 4-11 PULSE COUNT INPUT TIMING	49
FIGURE 4-12 TEST LOAD (ALL DYNAMIC PARAMETERS).....	49
FIGURE 5-1 HIGH RESISTANCE BUS HOLDING DEVICE ON THE W65C22S.....	50



Table of Tables

TABLE 2-1 W65C22 MEMORY MAP OF INTERNAL REGISTERS.....	8
TABLE 2-2 ORB, IRB OPERATION FOR REGISTER 0 (\$00).....	9
TABLE 2-3 ORA, IRA OPERATION FOR REGISTER 1 (\$01).....	10
TABLE 2-4 DDRB, DDRA OPERATION (\$02,\$03).....	10
TABLE 2-5 CA1, CA2, CB1, CB2 CONTROL1 (\$0C).....	12
TABLE 2-6 T1 COUNTER FORMAT AND OPERATION1 (\$04,\$05).....	14
TABLE 2-7 T1 LATCH FORMAT AND OPERATION1 (\$06,\$07).....	15
TABLE 2-8 AUXILIARY CONTROL REGISTER FORMAT AND OPERATION (\$0B).....	16
TABLE 2-9 T2 COUNTER FORMAT AND OPERATION1 (\$08,\$09).....	19
TABLE 2-10 SHIFT REGISTER AND AUXILIARY CONTROL REGISTER CONTROL (\$0A).....	21
TABLE 2-11 INTERRUPT FLAG REGISTER (\$0D).....	26
TABLE 2-12 INTERRUPT ENABLE REGISTER (\$0E).....	27
TABLE 3-1 PIN FUNCTION TABLE.....	29
TABLE 4-1 ABSOLUTE MAXIMUM RATINGS.....	37
TABLE 4-2A W65C22N DC CHARACTERISTICS.....	38

1. INTRODUCTION

The W65C22 (W65C22N and W65C22S) Versatile Interface Adapter (VIA) is a flexible I/O device for use with the 65xx series microprocessor family. The W65C22 includes functions for programmed control of two peripheral ports (Ports A and B). Two program controlled 8-bit bidirectional peripheral I/O ports allow direct interfacing between the microprocessor and selected peripheral units. Each port has input data latching capability. Two programmable Data Direction Registers (A and B) allow selection of data direction (input or output) on an individual line basis. Also provided are two programmable 16-bit Interval Timer/Counters with latches. Timer 1 may be operated in a One-Shot Interrupt Mode with interrupts on each count to zero, or in a Free-Run Mode with a continuous series of evenly spaced interrupts. Timer 2 functions as both an interval and pulse counter. Serial Data transfers are provided by a serial to parallel/parallel to serial shift register. Application versatility is further increased by various control registers, including an Interrupt Flag Register, an Interrupt Enable Register and two Function Control Registers.

KEY FEATURES OF THE W65C22

- Advanced CMOS process technology for low power consumption
- Compatible with various versions of the NMOS 6522 devices
- Low power consumption
- Two 8-bit, bi-directional peripheral I/O Ports
- Two 16-bit programmable Interval Timer/Counters
- Serial bi-directional peripheral I/O Port
- Enhanced "handshake" features
- Programmable Data Direction Registers
- Latched Input/Output Registers on both I/O Ports
- TTL compatible output peripheral lines
- Single 1.8V to 5V power supply
- Bus and functionally compatible with high-speed 8/16-bit 65xx as well other microprocessor families.
- Register and Chip Selects specified for multiplexed operation

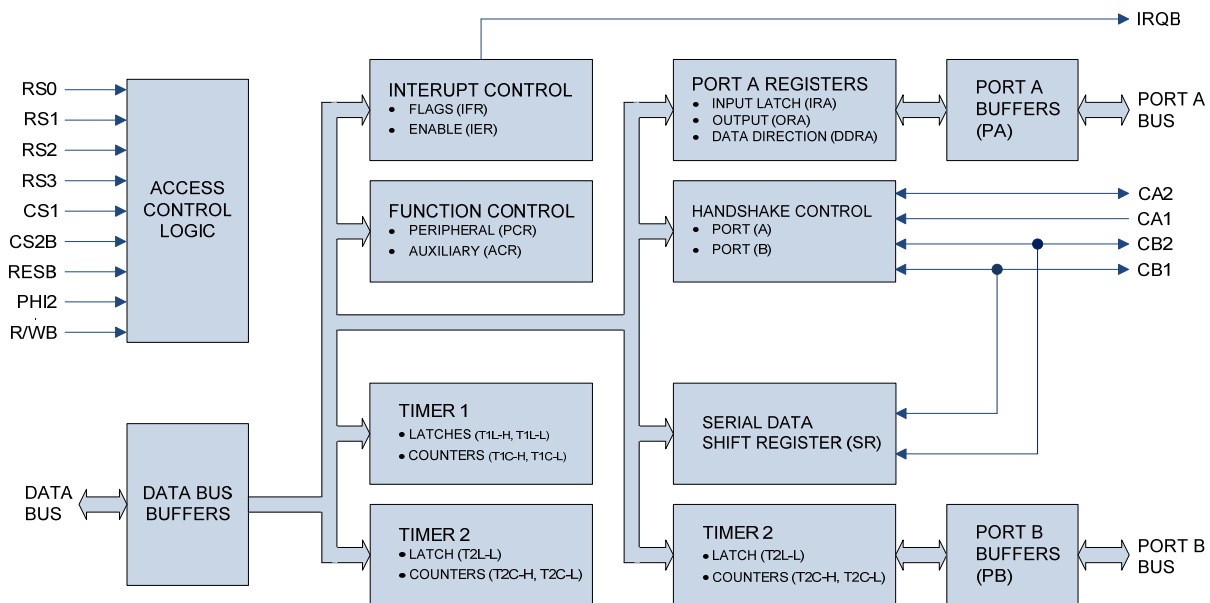


Figure 1-1 W65C22 Internal Architecture Block Diagram



2. W65C22 FUNCTION DESCRIPTION

Table 2-1 W65C22 Memory Map of Internal Registers

Register Number	RS Coding				Register Designation	Description	
	RS3	RS2	RS1	RS0		Write	Read
0	0	0	0	0	ORB/IRB	Output Register "B"	Input Register "B"
1	0	0	0	1	ORA/IRA	Output Register "A"	Input Register "A"
2	0	0	1	0	DDRB	Data Direction Register "B"	
3	0	0	1	1	DDRA	Data Direction Register "A"	
4	0	1	0	0	T1C-L	T1 Low-Order Latches	T1 Low-Order Counter
5	0	1	0	1	T1C-H	T1 High-Order Counter	
6	0	1	1	0	T1L-L	T1 Low-Order Latches	
7	0	1	1	1	T1L-H	T1 High-Order Latches	
8	1	0	0	0	T2C-L	T2 Low-Order Latches	T2 Low-Order Counter
9	1	0	0	1	T2C-H	T2 High-Order Counter	
A	1	0	1	0	SR	Shift Register	
B	1	0	1	1	ACR	Auxiliary Control Register	
C	1	1	0	0	PCR	Peripheral Control Register	
D	1	1	0	1	IFR	Interrupt Flag Register	
E	1	1	1	0	IER	Interrupt Enable Register	
F	1	1	1	1	ORA/IRA	Same as Reg 1 except no "Handshake"	

2.1 Peripheral Data Ports

Both PA and PB operate in conjunction with a Data Direction Register (DDRA or DDRB). Under program control, the DDRA and DDRB specify which pins within the port bus are to be designated as inputs or outputs. Logic 0 in any bit position of the register will cause the corresponding pin to serve as an input; while a logic 1 will cause the pin to serve as an output.

When a line is programmed as an output, it is controlled by a corresponding bit in the Output Register (ORA & ORB). A Logic 1 in the ORA or ORB will cause the corresponding output line to go high, while logic 0 will cause the pin to go low. Under program control, data is written into the ORA or ORB bit positions corresponding to the output pins which have been programmed as outputs. Should data be written into bit positions corresponding to pins which have been programmed as input, the output pins will be unaffected.

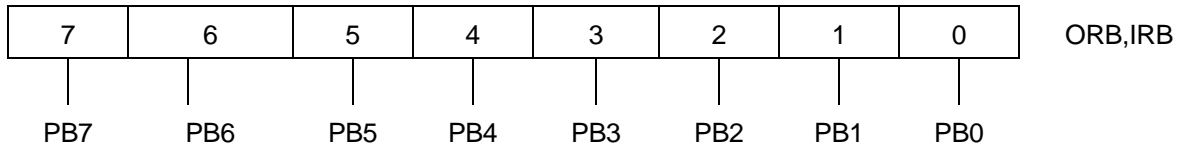


When reading the Peripheral Port (PA or PB), the contents of the corresponding Input Register (IRA or IRB) is transferred onto the Data Bus. When the input latching feature is disabled, IRA will reflect the logic levels present on the PA bus pins. However, with input latching enabled and the selected active transition on Peripheral A Control 1 (CA1) having occurred, IRA will contain the data present on the PA bus lines at the time of the transition. In this case, once IRA has been read, it will appear transparent, reflecting the current state of the PA bus pins until the next CA1 latching transition.

With respect to IRB, it operates similar to IRA except that for those PB bus pins that have been programmed as outputs, there is a difference. When reading IRA, the logic level on the pins determines whether logic 1 or 0 is read. However, when reading IRB, the logic level stored in ORB is the logic level read. For this reason, those outputs which have large loading effects may cause the reading of IRA to result in the reading of a logic 0 when a 1 was actually programmed, and reading logic 1 when a 0 was programmed. However, when reading IRB, the logic level read will be correct, regardless of loading on the particular pin.

For information on formats and operation of the PA and PB registers, see Tables 2-2, 2-3 & 2-4. Note that the input latching modes are controlled by the Auxiliary Control Register (See Table 1-8).

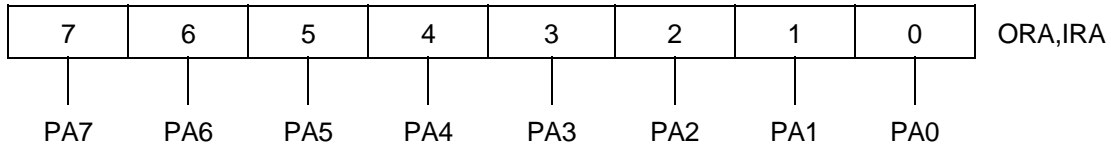
Table 2-2 ORB, IRB Operation for Register 0 (\$00)



Pin Data Direction Selection	WRITE	READ
DDRB="1" (Output)	MPU writes Output Level (ORB)	MPU reads output register bit in ORB. Pin level has no effect.
DDRB="0" (Input) (Input latching disabled)	MPU writes onto ORB, but no effect on pin level, until DDRB changed.	MPU reads input level on PB pin.
DDRB="0" (Input) (Input latching enabled)		MPU reads IRB bit, which is the level of the PB pin at the time of the last CB1 active transition.

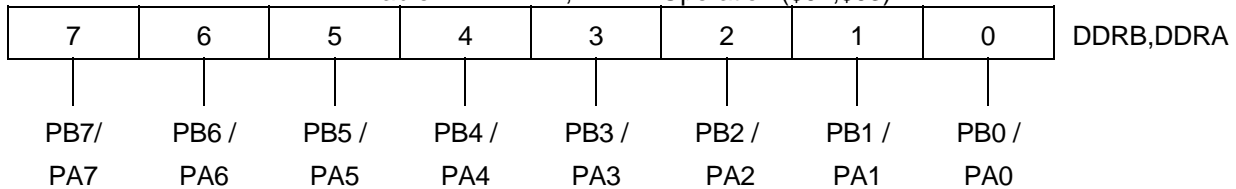


Table 2-3 ORA, IRA Operation for Register 1 (\$01)



Pin Data Direction Selection	WRITE	READ
DDRA="1" (Output) (Input latching disabled)	MPU writes Output Level (ORA)	MPU reads level on PA pin.
DDRA="1" (Output) (Input latching enabled)		MPU reads IRA bit which is the level of the PA pin at the time of the last CA1 active transition.
DDRA="0" (Input) (Input latching disabled)	MPU writes into ORA, but no effect on pin level, until DDRA changed.	MPU read level on PA pin.
DDRA="0" (Input) (Input latching enabled)		MPU reads IRA bit which is the level of the PA pin at the time of the last CA1 active transition.

Table 2-4 DDRB, DDRA Operation (\$02,\$03)



"0" Associated PB/PA pin is an input (high impedance)

"1" Associated PB/PA pin is an output, whose level is determined by ORB/ORA Bit.

2.2 Data Transfer - Handshake Control

A powerful feature of the W65C22 is its ability to provide absolute control over data transfers between the microprocessor and peripheral devices. This control is accomplished by way of "handshake" lines. PA lines Peripheral A Control 1, 2 (CA1, CA2) handshake data transfers on both Read and Write operations, while PB lines Peripheral B Control 1,2 (CB1, CB2) handshake data on Write operations only.



2.3 Read Handshake Control.

Read Handshaking provides effective control of data transfers from a peripheral device to the microprocessor. To accomplish the Read Handshake, the peripheral device generates a Data Ready signal to the W65C22N that indicates valid data is present on PA or PB. In most cases, this Data Ready signal will interrupt the microprocessor, which will then read the data and generate a Data Taken signal. Once the peripheral senses the Data Taken signal, new data will be placed on the bus. This process continues until the data transfer is complete.

Automatic Read Handshaking applies to PA only. The Data Ready signal is transmitted by the peripheral device over the CA1 interrupt line, while the Data Taken signal is generated and transmitted to the peripheral device over the CA2 line. When the Data Ready signal is received, it sets an internal flag in the Interrupt Flag Register (IFR). This flag may interrupt the microprocessor or it may be polled under program control. As an option, the Data Taken signal may be either a pulse or a level. In either case, it is set to a Logic 0 by the microprocessor and is set by the next Data Ready signal, see Figure 2-1.

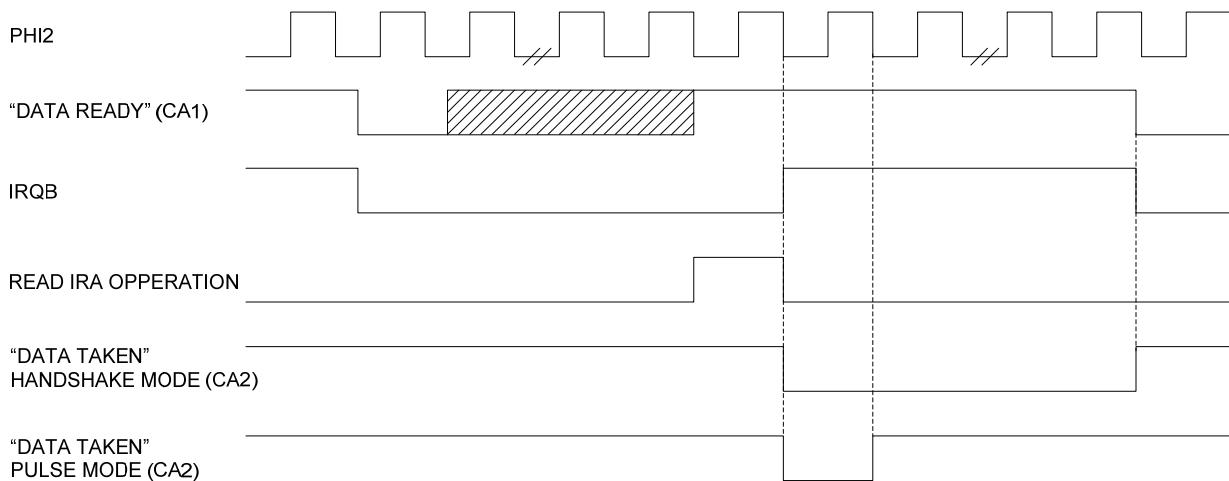


Figure 2-1 Read Handshake Operation (PA Only)



2.4 Write Handshake Control.

The Write Handshake operation is similar to Read Handshaking. For Write Handshaking, however, the W65C22 generates the Data Ready signal and the peripheral device must generate the Data Taken return signal. Note that Write Handshaking may occur on both PA and PB. For a Write Handshake, CA2 or CB2 serve as the Data Ready output and can operate in either the Handshake Mode or the Pulse Mode. The Data Taken signal is received the CA1 or CB1. The Data Taken signal sets a flag in the Interrupt Flag Register and clears the Data Ready output signal, see Figure 2-2.

Note that the selection of Read or Write Handshake operating modes for CA1, CA2, CB1 and CB2 is accomplished by the Peripheral Control Register (PCR). See Table 2-5.

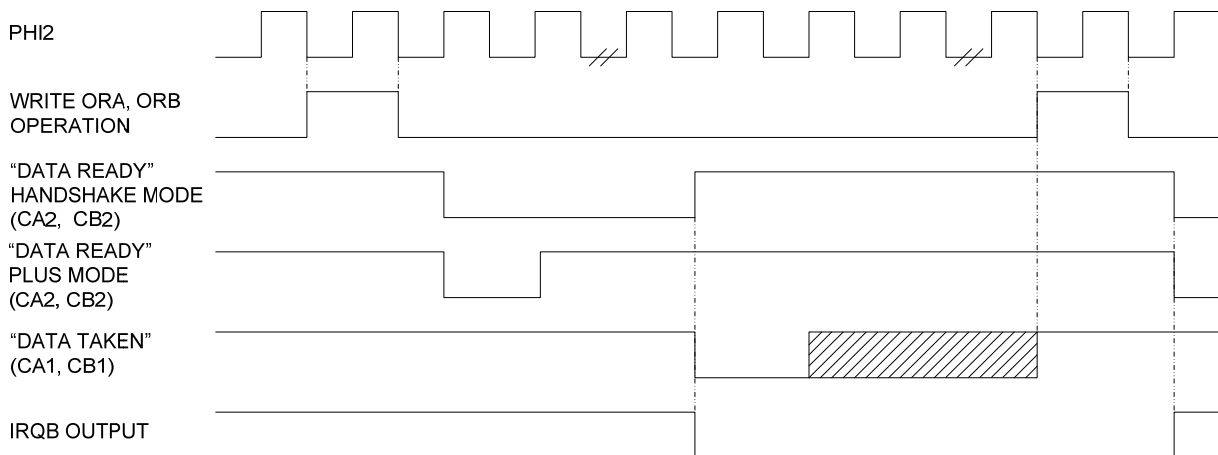


Figure 2-2 Write Handshake (PA and PB)

Table 2-5 CA1, CA2, CB1, CB2 Control (\$0C)

7	6	5	4	3	2	1	0	PCR
CB2 Control			CB1 Control	CA2 Control			CA1 Control	



CB2 Control

7	6	5	Operation
0	0	0	Input-negative active edge
0	0	1	Independent interrupt input-negative edge*
0	1	0	Input-positive active edge
0	1	1	Independent interrupt input-positive edge*
1	0	0	Handshake output
1	0	1	Pulse output
1	1	0	Low output
1	1	1	High output

CB1 Interrupt Control

0 = Negative Active Edge
1 = Positive Active Edge

CA2 Control

3	2	1	Operation
0	0	0	Input-negative active edge
0	0	1	Independent interrupt input-negative edge*
0	1	0	Input-positive active edge
0	1	1	Independent interrupt input-positive edge*
1	0	0	Handshake output
1	0	1	Pulse output
1	1	0	Low output
1	1	1	High output

CA1 Interrupt Control

0 = Negative Active Edge
1 = Positive Active Edge

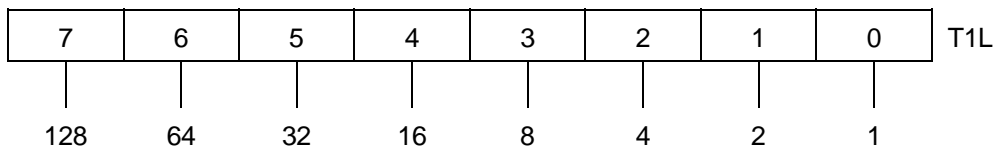
* If the CA2/CB2 control in the PCR is selected as "independent" interrupt input, then reading or writing the output register ORA/ORB will not clear the flag bit. Instead, the bit must be cleared by writing into the IFR, as described previously.



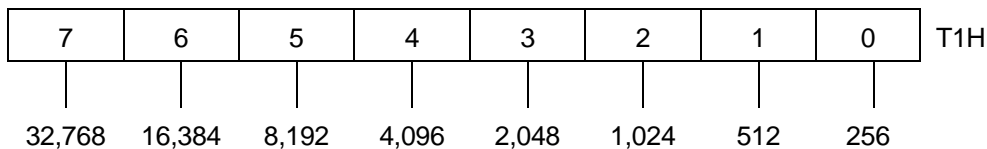
2.5 Timer 1 Operation

Interval Timer 1 (T1) consists of two 8-bit latches and a 16-bit counter. The latches serve to store data which is to be loaded into the counter. Once the counter is loaded under program control, it decrements at Phase 2 clock rate. Upon reaching zero, bit 6 of the Interrupt Flag Register (IFR) is set, causing Interrupt Request (I) to go to Logic 0 if the corresponding bit in the Interrupt Enable Register (IER) is set. Once the Timer reaches a count of zero, it will either disable any further interrupts (provided it has been programmed to do so), or it will automatically transfer the contents of the latches into the counter and proceed to decrement again. The counter may also be programmed to invert the output signal on PB7 each time it reaches a count of zero. Each of these counter modes is presented below. The T1 counter format and operation is shown in Table 2-6, with corresponding latch format and operation in Table 2-7. Additional control bits are provided in the Auxiliary Control Register (ACR) bits 6 and 7 to allow selection of T1 operating modes. The four available modes are shown in Table 2-8.

Table 2-6 T1 Counter Format and Operation1 (\$04,\$05)



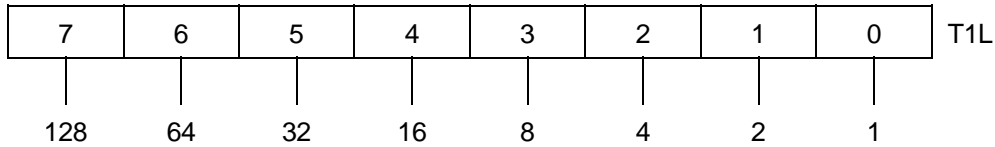
- WRITE - 8 bits loaded into T1 low order latches. Latch contents are transferred into low order counter at the time the high order counter is loaded.
- READ - 8 bits from T1 low order counter transferred to MPU. T1 interrupt flag IFR6 is reset.



- WRITE - 8 bits loaded into T1 high order latches. Also, both high and low order latches are transferred into T1 counter and this initiates countdown. T1 interrupt flag IFR6 is reset.
- READ - 8 bits from T1 high order counter transferred to MPU.

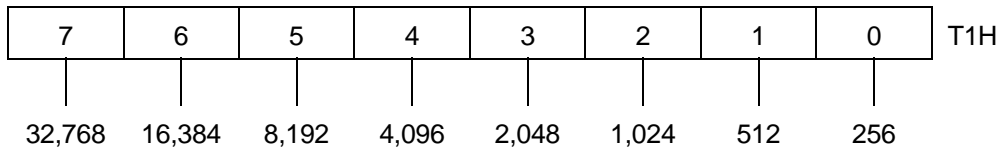


Table 2-7 T1 Latch Format and Operation1 (\$06,\$07)



WRITE - 8 bits loaded into T1 low order latches. This operation is no different than a write into the T1 Low Order Register.

READ - 8 bits from T1 low order latches transferred to MPU. Unlike reading the T1 Low Order Register, this does not cause reset of T1 interrupt flag IFR6.



WRITE - 8 bits loaded into T1 high order latches. Unlike writing to the T1 Low Order Register, no latch to counter transfers takes place. T1 interrupt flag IFR6 is reset.

READ - 8 bits from T1 high order counter transferred to MPU.



Table 2-8 Auxiliary Control Register Format and Operation (\$0B)

7	6	5	4	3	2	1	0	ACR
T1 Timer Control		T2 Timer Control	Shift Register Control			PB	PA	

T1 Timer Control

7	6	Operation	PB7
0	0	Timed interrupt each time T1 is loaded	Disabled
0	1	Continuous interrupts	
1	0	Timed interrupt each time T1 is loaded	One shot output
1	1	Continuous interrupts	Square wave output

T2 Timer Control

5	Operation
0	Timed interrupt
1	Count down with pulses on PB6

Shift Register Control

4	3	2	Operation
0	0	0	Disabled
0	0	1	Shift in under control of T2
0	1	0	Shift in under control of PHI2
0	1	1	Shift in under control of external clock
1	0	0	Shift out free running at T2 rate
1	0	1	Shift out under control of T2
1	1	0	Shift out under control of PHI2
1	1	1	Shift out under control of external clock

Latch Enable/Disable

1	0	Operation
0	0	Disable
1	1	Enable latching



It should be noted that the microprocessor does not write directly into the T1 low order counter. Instead, this half of the counter is loaded automatically from the low order register when the microprocessor writes into the high order register and counter. In fact, it may not be necessary to write to the low order register in some applications since the timing operation is triggered by writing to the high order register and counter.

2.6 Timer 1 One-Shot Mode

Interval Timer T1 may operate in the One-Shot Mode that allows the generation of a single Interrupt Flag each time the Timer is loaded. The Timer can also be programmed to produce a single negative pulse on Data Port line PB7.

To generate a single interrupt, it is required that bits 6 and 7 of the ACR be a Logic 0. The low order T1 counter or the low order T1 latch must then be loaded with the low order count value. Note that a load to a low order T1 counter is effectively a load to a low order T1 latch. Next, the high order count value must be loaded into the high order T1 counter, at which time the value is simultaneously loaded into the high order T1 latch. During this load sequence, the contents of low order T1 latch is transferred to low order T1 counter. The counter will start counting down on the next PHI2 clock following the load sequence into high order T1 counter, and will decrement at the PHI2 clock rate. Once the T1 counter reaches a zero count, the Interrupt Flag is set. To generate a negative pulse on PB7, the sequence is identical to the above except ACR7 must be a Logic 1. PB7 will then go to a Logic 0 following the load to high order T1 counter, and will go to a Logic 1 again when the counter reaches a zero count. Once set, IFR6 the T1 Interrupt Flag is reset by either writing high order T1 latch, or by reading low order T1 counter, see Figure 2-3.

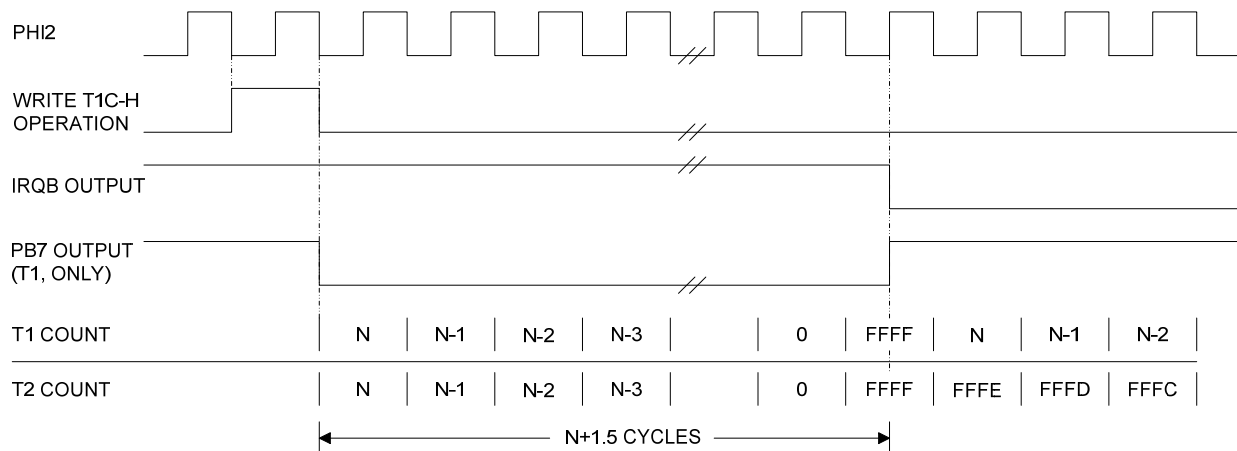


Figure 2-3 One-Shot Mode (Timer 1 and Timer 2)



2.7 Timer 1 Free-Run Mode

An important advantage within the W65C22 is the ability of the latches associated with the T1 counter to provide a continuous series of evenly spaced interrupts or a square wave on PB7. It should also be noted that the continuous series of interrupts and square waves are not affected by variations in the microprocessor interrupt response time. These advantages are all produced in the Free-Run Mode. When operating in the Free-Run Mode, the Interrupt Flag is set and the signal on PB7 is inverted each time the counter reaches a count of zero. In the Free-Run Mode, however, the counter does not continue to decrement after reaching a zero count. Instead, the counter automatically transfers to contents of the latch into the counter (16 bits) and then decrements from the new count value. As can be seen, it is not necessary to reload the timer in order to set the Interrupt Flag on the next count of zero. When the Interrupt Flag bit is set it can be cleared by either reading low order T1 counter or by writing directly into the IFR as will be discussed later or by writing into high order T1 latch.

Since the interval timers are all re-triggerable, reloading the counter will always reinitialize the time out period. Should the microprocessor continue to reload the counter before it reaches zero, counter time out can be prevented. T1 is able to operate in this manner provided the microprocessor writes into the high order counter. By loading the latches only, the microprocessor can access the timer during each countdown operation without affecting the time out in progress. In this way, data loaded into the latches will determine the length of the next subsequent time out period. This capability is of value in the Free-Run Mode with the output enabled. In the Free-Run Mode, the signal on PB7 is inverted and IFR6 is set with each counter time out. When the microprocessor responds to the interrupts with new data for the latches, it can determine the period of the next half cycle during each half cycle of the output signal on PB7. In this way, complex waveforms can be generated. See Figure 2-4.

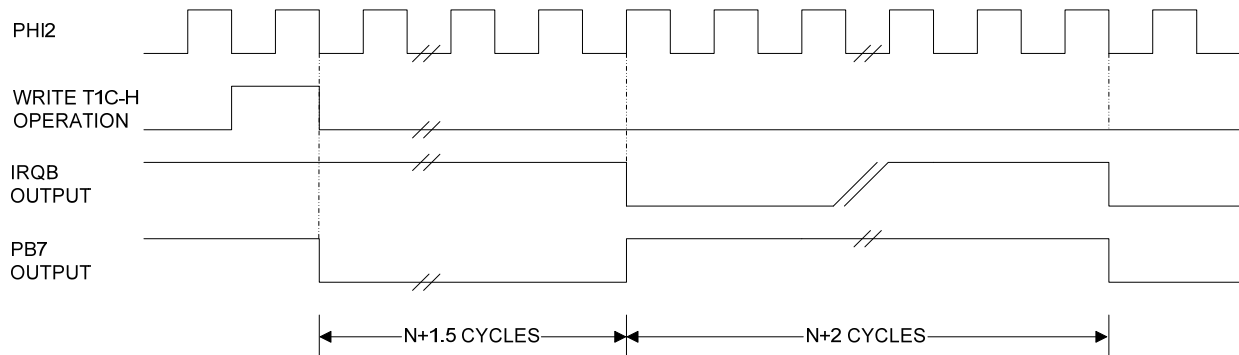


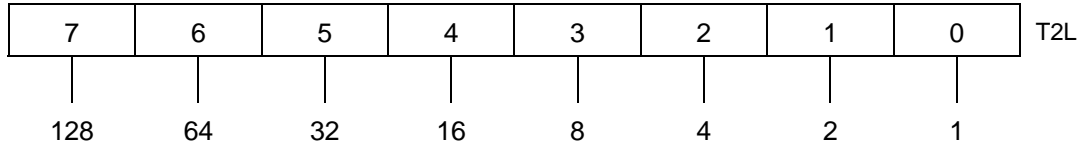
Figure 2-4 Free-Run Mode (Timer 1)



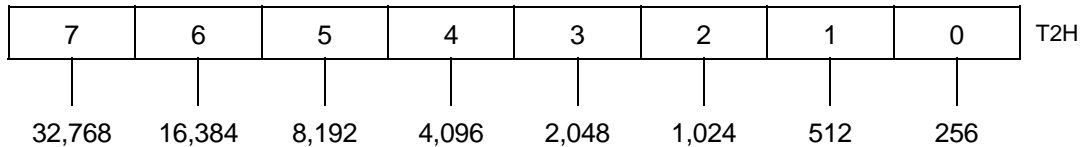
2.8 Timer 2 Operation

Timer 2 (T2) operates in the One-Shot Mode only (as an interval timer), or as a pulse counter for counting negative pulses on PB6. A single control bit within ACR5 is used to select between these two modes. T2 is made up of a write only low order T2 latch, a read only low order T2 counter, and a read/write high order T2 counter. This 16-bit counter decrements at a PHI2 clock rate. See Table 2-9.

Table 2-9 T2 Counter Format and Operation1 (\$08,\$09)



WRITE - 8 bits loaded into T2 low order latches.
 READ - 8 bits from T2 low order counter transferred to MPU. IFR5 is reset.



WRITE - 8 bits loaded into T2 high order counter. Also, low order latches are transferred to low order counter. IFR5 is reset.
 READ - 8 bits from T2 high order counter transferred to MPU.

2.9 Timer 2 One-Shot Mode

Operation of T2 in the One-Shot Mode is similar to T1. That is, for each load high order T2 counter operation, Timer 2 sets IFR5 for each countdown to zero. However, after a time out, the T2 counters roll over to all 1's (\$FFFF) and continues to decrement. This two's complement decrement allows the user to determine how long IFR5 has been set. Since the Interrupt Flag logic is disabled after the initial interrupt set (zero count), further interrupts cannot be set by a subsequent count to zero. To enable the Interrupt Flag logic, the microprocessor must reload high order T2 counter. The Interrupt Flag is cleared by either reading low order T2 counter or by loading high order T2 counter. See Figure 2-3.



2.10 Timer 2 Pulse Counting Mode

In the Pulse Counting Mode, T2 counts a predetermined number of negative going pulses on PB6. To accomplish this, a count number is loaded into high order T2 counter, which clears IFR5 logic and starts the counter to decrement each time a negative pulse is applied to PB6. When the T2 counter reaches a count of zero, IFR5 is set and the counter continues to decrement with each pulse on PB6. To enable IFR5 for subsequent countdowns, it is necessary to reload high order T2 counter. The decrement pulse on line PB6 must be Logic 0 during the leading edge of the PHI2 clock. See Figure 2-5.

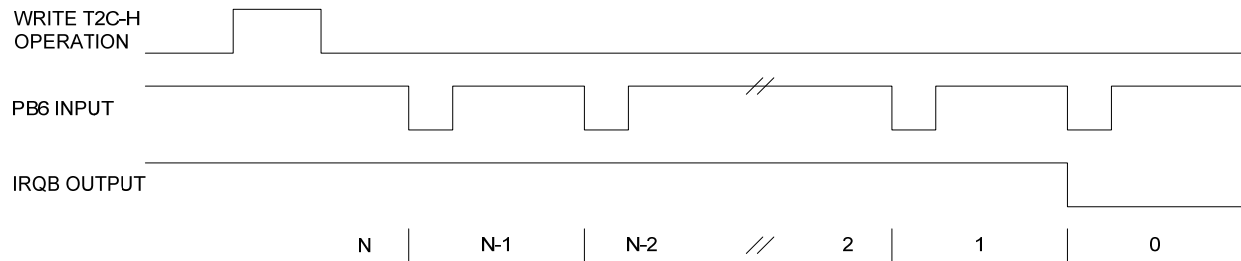


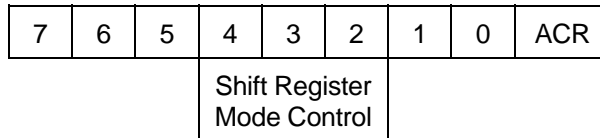
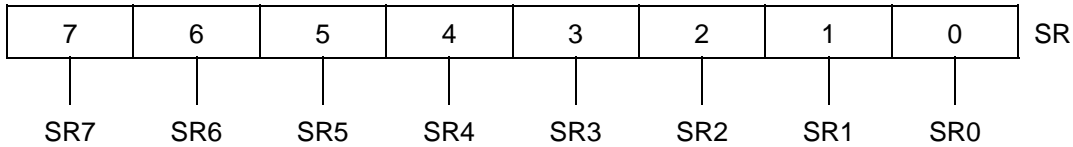
Figure 2-5 Pulse Counting Mode (Timer 2)

2.11 Shift Register Operation

The Shift Register (SR) performs bidirectional serial data transfers on line CB2. These transfers are controlled by an internal modulo-8 counter. Shift pulses can be applied to the CB1 line from an external source, or (with proper mode selection) shift pulses may be generated internally which will appear on the CB1 line for controlling external devices. Each SR operating mode is controlled by control bits within the ACR. See Table 2-10 for control bit information. See also Figures 2-6 through 2-12.



Table 2-10 Shift Register and Auxiliary Control Register Control (\$0A)



Shift Register Control

4	3	2	Operation
0	0	0	Disabled
0	0	1	Shift in under control of T2
0	1	0	Shift in under control of PHI2
0	1	1	Shift in under control of external clock (CB1)
1	0	0	Shift out free running at T2 rate
1	0	1	Shift out under control of T2
1	1	0	Shift out under control of PHI2
1	1	1	Shift out under control of external clock (CB1)

- Notes: 1. When shifting out, bit 7 is the first bit out and simultaneously is rotated back into bit 0.
2. When shifting in, bits initially enter bit 0 and are shifted towards bit 7.

2.12 Shift Register Input Modes

2.12.1 Shift Register Disabled (000)

In the 000 mode, the SR is disabled from all operation. The microprocessor can read or write the SR, but shifting is disabled and both CB1 and CB2 are controlled by bits in the PCR. The Shift Register Interrupt Flag (IFR2) is held low (disabled).

2.12.2 Shift In - Counter T2 Control (001)

In this mode, the shifting rate is controlled by the low order eight bits of counter T2. Shift pulses are generated on the CB1 line to control shifting in external devices. The time between transitions of the CB1 output clock is determined by the PHI2 clock period and the contents of the low order T2 latch (N). Shifting occurs by writing or reading the SR. Data is shifted into the low order bit first, and is then shifted into the next higher order bit on the negative going edge of each clock pulse. Input data should change before the positive going edge of the CB1 clock pulse. This data is then shifted into the SR during the PHI2 clock cycle following the positive going edge of the CB1 clock pulse. After eight CB1 clock pulses, IFR2 will set and IRQB will go to a Logic 0. See Figure 2-6.

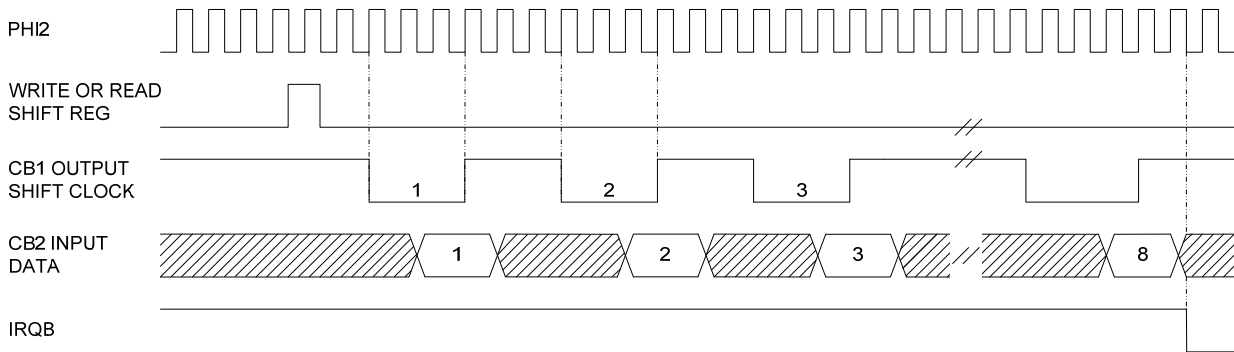


Figure 2-6 Shift In - Counter T2 Control

2.12.3 Shift In - PHI2 Clock Control (010)

In this mode, the shift rate is controlled by the PHI2 clock frequency. Shift pulses are generated on the CB1 line to control shifting in external devices. Timer 2 operates as an independent interval time and has no influence on the SR. Shifting occurs by reading or writing the SR. Data is shifted into the low order bit first, and is then shifted into the next higher order bit on the trailing edge of the PHI2 clock pulse. After eight clock pulses, IFR2 will be set, and output clock pulses on the CB1 line will stop. See Figure 2-7.

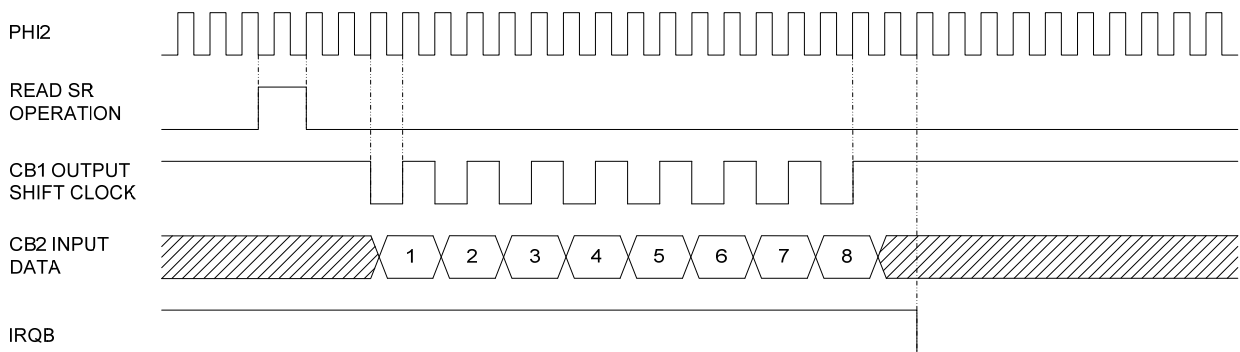


Figure 2-7 Shift In - PHI2 Clock Control

2.12.4 Shift In - External CB1 Clock Control (011)

In this mode, CB1 serves as an input to the SR. In this way, an external device can load the SR at its own pace. The SR counter will interrupt the microprocessor after each eight bits have been shifted in. The SR counter does not stop the shifting operation. Its function is simply that of a pulse counter. Reading or writing the SR resets IFR2 and initializes the counter to count another eight pulses. Note that data is shifted during the first PHI2 clock cycle following the positive going edge of the CB1 shift pulse. For this reason, data must be held stable during the first full cycle following CB1 going high. See Figure 2-8.

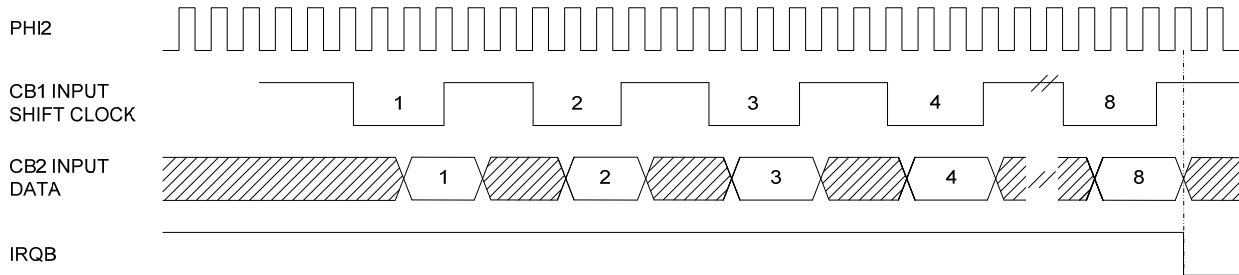


Figure 2-8 Shift In - External CB1 Clock Control Timing

2.13 Shift Register Output Modes

2.13.1 Shift Out - Free Running at T2 Rate (100)

This mode is similar to mode 101 in which the shifting rate is determined by T2. However, in mode 100 the SR Counter does not stop the shifting operation. Since SR7 is re circulated back into SR0, the eight bits loaded into the SR will be clocked onto the CB2 line repetitively. In this mode, the SR Counter is disabled and IRQB is never set. See Figure 2-9.

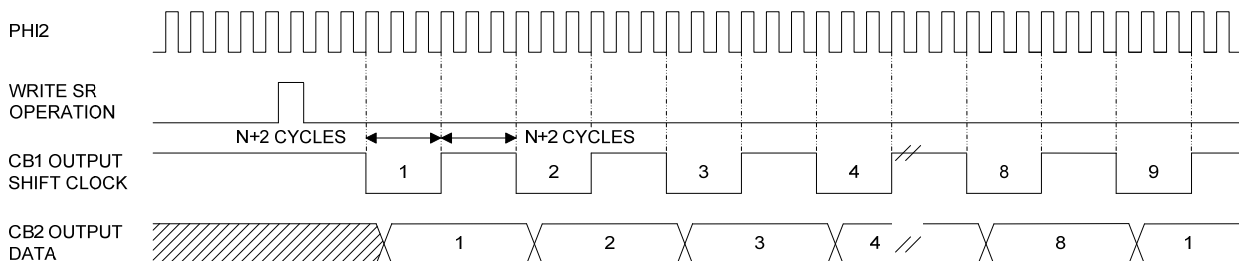


Figure 2-9 Shift Out - Free Running T2 Rate Timing



2.13.2 Shift Out - T2 Control (101)

In this mode, the shift rate is controlled by T2 (as in mode 100). However, with each read or write of the SR Counter is reset and eight bits are shifted onto the CB2 line. At the same time, eight shift pulses are placed on the CB1 line to control shifting in external devices. After the eight shift pulses, the shifting is disabled, IFR2 is set, and CB2 will remain at the last data level. See Figure 2-10.

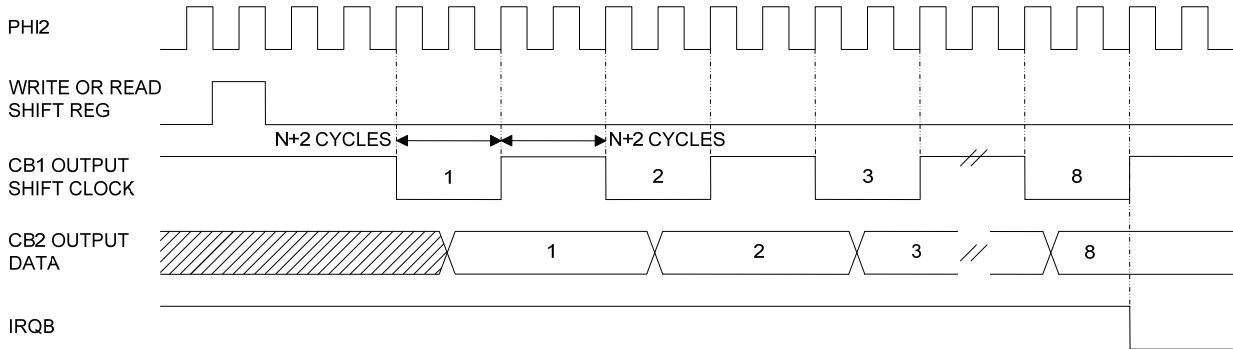


Figure 2-10 Shift Out - T2 Control Timing

2.13.3 Shift Out - PHI2 Clock Control (110)

In this mode, the shift rate is controlled by the system PHI2 clock. See Figure 2-11.

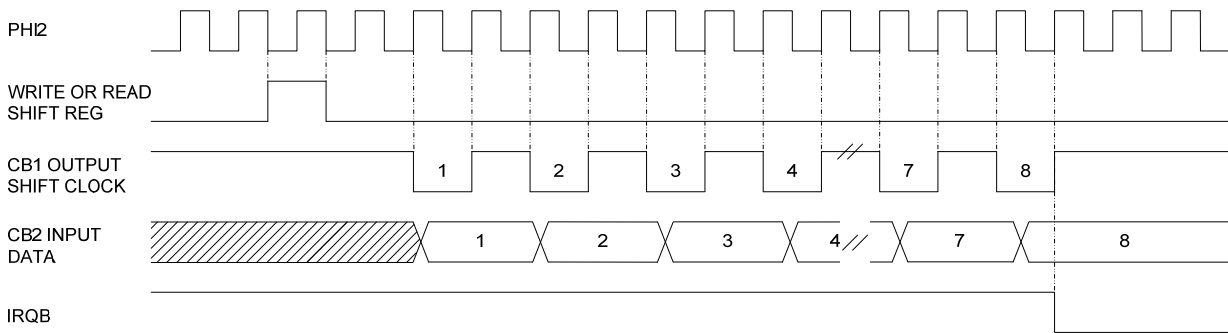


Figure 2-11 Shift Out - PHI2 Control Timing



2.13.4 Shift Out - External CB1 Clock Control (111)

In the mode, shifting is controlled by external pulses applied to the CB1 line. The SR Counter sets IFR2 for each eight pulse count, but does not disable the shifting function. Each time the microprocessor reads or writes the SR, IFR2 is reset and the counter is initialized to begin counting the next eight pulses on the CB1 line. After eight shift pulses, IFR2 is set. The microprocessor can then load the SR with the next eight bits of data. See Figure 2-12.

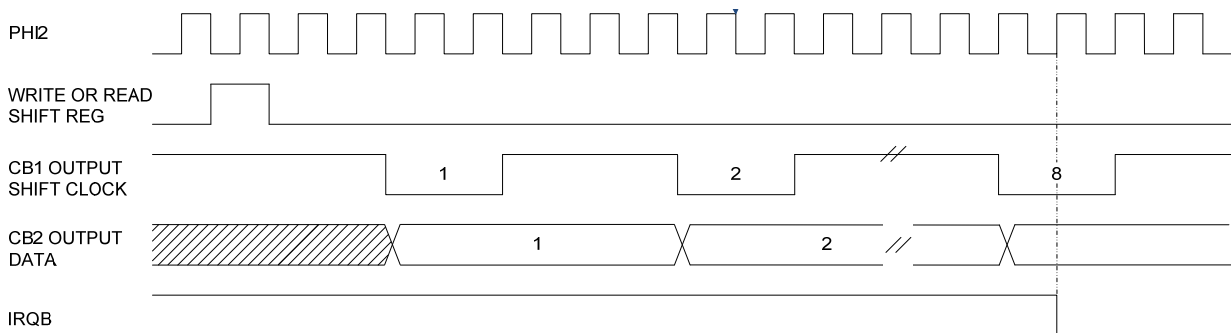


Figure 2-12 Shift Out - External CB1 Clock Control Timing

2.14 Interrupt Operation

There are three basic interrupt operations, including: setting the interrupt flag within IFR, enabling the interrupt by way of a corresponding bit in the IER, and signaling the microprocessor using IRQB. An Interrupt Flag can be set by conditions internal to the chip or by inputs to the chip from external sources. Normally, an Interrupt Flag will remain set until the interrupt is serviced. To determine the source of an interrupt, the microprocessor must examine each flag in order, from highest to lowest priority. This is accomplished by reading the contents of the IFR into the microprocessor accumulator, shifting the contents either left or right and then using conditional branch instructions to detect an active interrupt. Each Interrupt Flag has a corresponding Interrupt Enable bit in the IER. The enable bits are controlled by the microprocessor (set or reset). If an Interrupt Flag is a Logic 1, and the corresponding Interrupt Enable bit is a Logic 1, the IRQB will go to a Logic 0. IRQB on the W65C22S is a full output driver that allows both Logic 1 and Logic 0 levels. The W65C22N and older NMOS and CMOS IRQB output is/was open drain pull down only. The W65C22S IRQB should be logically ORed to reduce power and increase speed or wired ORed with other devices using a diode that is forward biased when IRQB is low.

All Interrupt Flags are contained within a single IFR. Bit 7 of this register will be Logic 1 whenever an Interrupt Flag is set, thus allowing convenient polling of several devices within a system to determine the source of the interrupt.

The IFR and IER format and operation is shown in Tables 2-11 and 2-12. The IFR may be read directly by the microprocessor, and individual flag bits may be cleared by writing a Logic 1 into the appropriate bit of the IFR. Bit 7 of the IFR indicates the status of the IRQB output. Bit 7 corresponds to the following logic function:

$$IRQ = IFR6 \wedge IER6 \vee IFR5 \wedge IER5 \vee IFR4 \wedge IER4 \vee IFR3 \wedge IER3 \vee IFR2 \wedge IER2 \vee IFR1 \wedge IER1 \vee IFR0 \wedge IER0.$$

Note: \wedge = Logical AND, \vee = Logical OR.

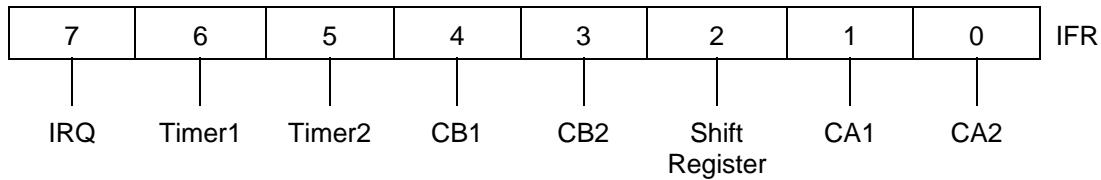


IFR7 is not a flag. Therefore, IFR7 is not directly cleared by writing a Logic 1 into its bit position. It can be cleared, however, by clearing all the flags within the register, or by disabling all active interrupts as presented in the next section.

Each Interrupt Flag within the IFR has a corresponding enable bit in IER. The microprocessor can set or clear selected bits within the IER. This allows the control of individual interrupts without affecting others. To set or clear a particular Interrupt Enable bit, the microprocessor must write to the IER address. During this write operation, if IER7 is Logic 0, each Logic 1 in IER6 thru IER0 will clear the corresponding bit in the IER. For each Logic 0 in IER6 thru IER0, the corresponding bit in the IER will be unaffected.

Setting selected bits in the IER is accomplished by writing to the same address with IER7 set to a Logic 1. In this case, each Logic 1 in IER6 through IER0 will set the corresponding bit to a Logic 1. For each Logic 0 the corresponding bit will be unaffected. This method of controlling the bits in the IER allows convenient user control of interrupts during system operation. The microprocessor can also read the contents of the IER by placing the proper address on the Register Select and Chip Select inputs with the RWB line high. IER7 will be read as a Logic 1.

Table 2-11 Interrupt Flag Register (\$0D)

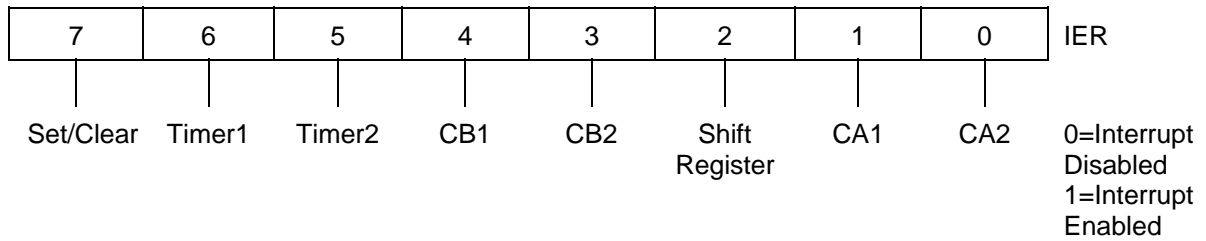


BIT	SET BY	CLEARED BY
0	CA2 active edge	Read or write ORA*
1	CA1 active edge	Read or write ORA
2	Complete 8 shifts	Read or write Shift Reg.
3	CB2 active edge	Read or write ORB*
4	CB1 active edge	Read or write ORB
5	Time out of T2	Read T2 low or write T2 high
6	Time out of T1	Read T1C-L low or write T1L-H high
7	Any enabled interrupt	Clear all interrupts

* If the CA2/CB2 control in the PCR is selected as "independent" interrupt input, then reading or writing the output register ORA/ORB will not clear the flag bit. Instead, the bit must be cleared by writing into the IFR, as described previously.



Table 2-12 Interrupt Enable Register (\$0E)



Notes:

1. If bit 7 is a "0", then each Logic 1 in bits 0-6 disables the corresponding interrupt.
2. If bit 7 is a "1", then each Logic 1 in bits 0-6 enables the corresponding interrupt.
3. If a read of this register is done, bit 7 will be Logic 1 and all other bits will reflect their enable/disable state.

3. PIN FUNCTION DESCRIPTION

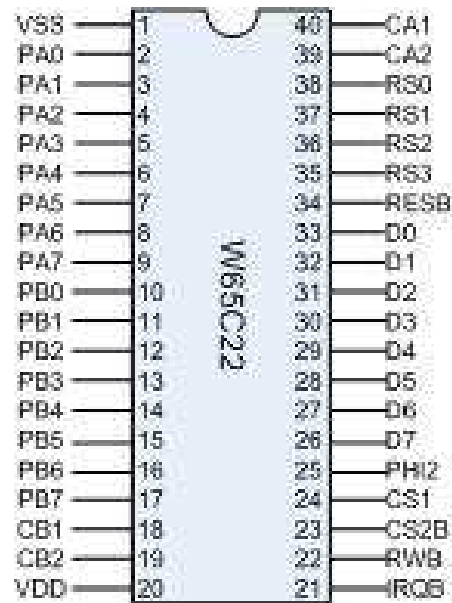


Figure 3-1 W65C22 40 Pin PDIP Pinout

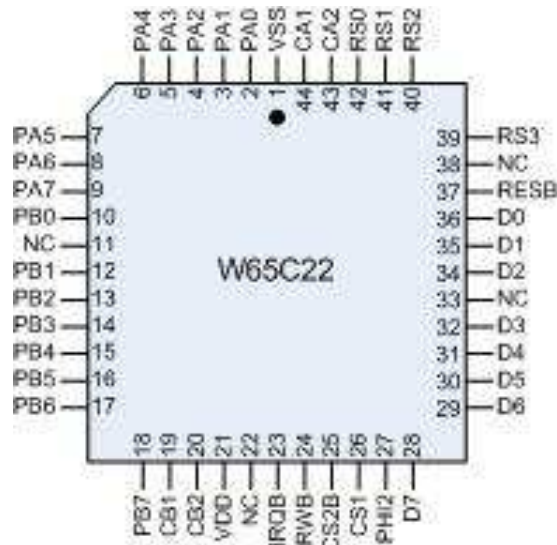


Figure 3-2 W65C22 44 Pin PLCC Pinout

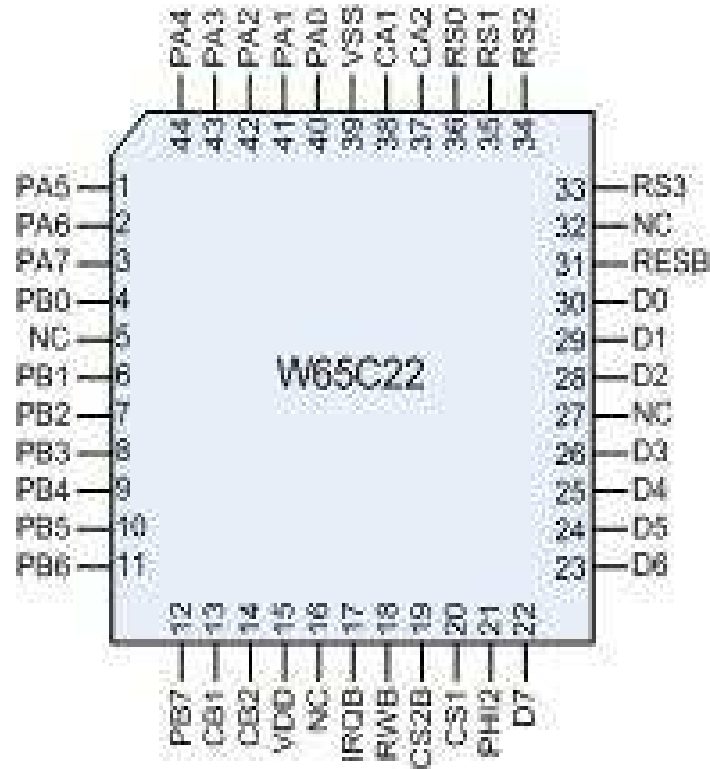


Figure 3-3 W65C22 44 Pin QFP Pinout



Table 3-1 Pin Function Table

Pin	Description
CA1, CA2	Peripheral A Control Lines
CB1, CB2	Peripheral B Control Lines
CS1, CS2B	Chip Select
D0-D7	Data Bus
IRQB	Interrupt Request
PA0-PA7	Peripheral I/O Port A
PB0-PB7	Peripheral I/O Port B
PHI2	Phase 2 Internal Clock
RESB	Reset
RS0-RS3	Register Select
R/WB	Read/Write
VDD	Positive Power Supply
VSS	Internal Logic Ground

3.1 Peripheral Data Port A Control Lines (CA1, CA2)

CA1 and CA2 serve as interrupt inputs or handshake outputs for PA. Each line controls an internal Interrupt Flag with a corresponding Interrupt Enable bit. CA1 also controls the latching of Input Data on PA. CA1 and CA2 are high impedance CMOS inputs with a bus holding device. In the output mode, CA2 will drive two standard TTL loads.

3.2 Peripheral Data Port B Control Lines (CB1, CB2)

CB1 and CB2 serve as interrupt inputs or handshake outputs for PB. Like PA, these two control lines control an internal Interrupt Flag with a corresponding Interrupt Enable bit. These lines also serve as a serial data port under control of the SR. Each control line represents a CMOS input with a bus holding device in the input mode and can drive two standard TTL loads in the output mode.

3.3 Chip Select (CS1, CS2B)

Normally, CS1 and CS2B are connected to the microprocessor address lines. This connection may be direct or through decoding. To access a selected W65C22 register, CS1 must be logic 1 and CS2B must be logic 0. These pins have a bus holding devices on the W65C22S.



3.4 Data Bus (D0-D7)

The eight bidirectional lines D0-D7 are used to transfer data between the W65C22 and the microprocessor. During a Read operation, the contents of the selected W65C22 internal register are transferred to the microprocessor via D0-D7. During a Write operation, D0-D7 serve as high impedance inputs over which data is transferred from the microprocessor to a selected W65C22 register. D0-D7 are in the high impedance state when the W65C22 is unselected. The W65C22S has a bus holding device, in case the bus tries to float, the data bus will be held in its previous state.

3.5 Interrupt Request (IRQB)

The IRQB output signal is logic 0 whenever an internal Interrupt Flag bit is set to logic 1 and the corresponding Interrupt Enable bit is logic 1. The IRQB output is a full output driver that outputs both logic 1 and logic 0 levels. The W65C22N and older NMOS and CMOS IRQB output is/was an open drain pull down only, thus allowing the IRQB signal to be wire ORed with an external resistor for a common microprocessor IRQB input line. The W65C22S IRQB can be wire ORed with a pull down diode that is forward biased when IRQB is low. See Figure 3.4 IRQB for the IRQB buffer schematics for both the W65C22N and W65C22S.

The IRQB pin on the W65C22S is a standard totem pole output. The W65C22S IRQB signal was meant for logically ORing rather than wire ORing the IRQ's of a system. This change was made to improve the low power, high speed characteristics of the part. For systems that have wire ORed IRQB outputs a solution is to place a low voltage diode (<0.5V) in series with the W65C22S totem pole IRQB output.

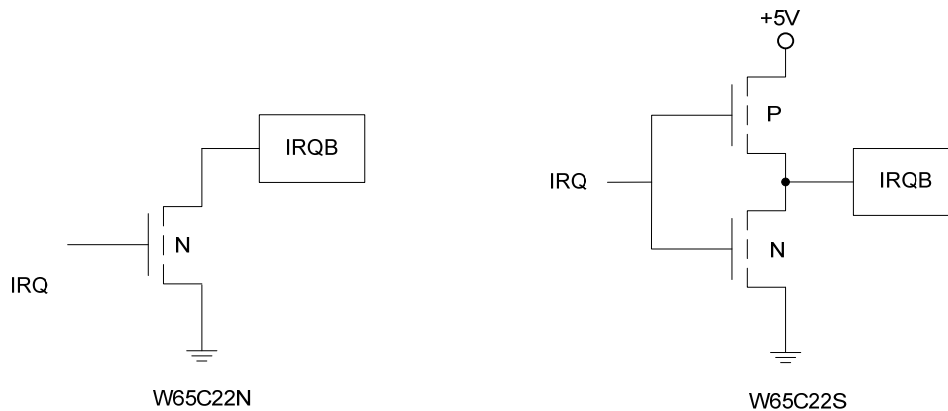


Figure 3-4 IRQB Buffer - W65C22N and W65C22S

3.6 Peripheral Data Port A (PA0-PA7)

PA is an 8 line, bidirectional bus used for the transfer of data, control and status information between the W65C22 and a peripheral device. Each PA bus line may be individually programmed as either an input or output under control of DDRA. Data flow direction may be selected on a line by line basis with intermixed input and output lines within the same port. When logic 0 is written to any bit position of DDRA, the corresponding line will be programmed as an input. Likewise, when logic 1 is written into any bit position of the register, the corresponding data pin will serve as an output. The data read is determined by ORA when input data is latched into the IRA under control of the CA1 line. All modes are program controlled by way of the W65C22's internal control registers. Each PA line represents a CMOS capacitive load in the input mode and will drive two standard TTL loads in the output mode.

The PA data port of the W65C22S has improved high impedance CMOS inputs, bus holding devices and high speed CMOS output drive for logic 1 level. This allows for higher speed operation no longer dependent on the RC time constant of older NMOS and CMOS designs. See Figures 3-5 through 3-8 for buffer schematic comparisons with W65C22N, W65C22S and legacy obsolete versions.

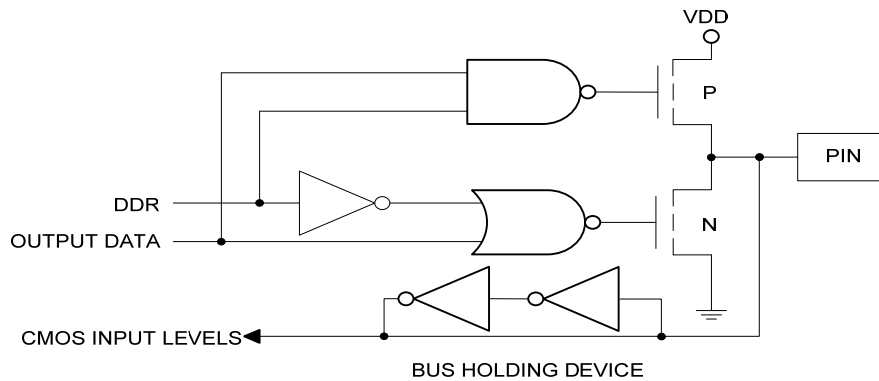


Figure 3-5 W65C22S Port A Buffer (PA0-PA7, CA2)

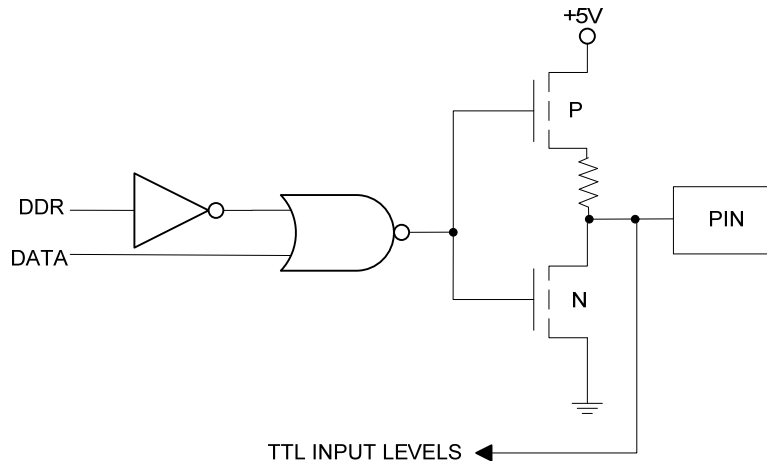


Figure 3-4 W65C22N and GTE - G65SC22 CMOS Port A Buffer (PA0-PA7, CA2)

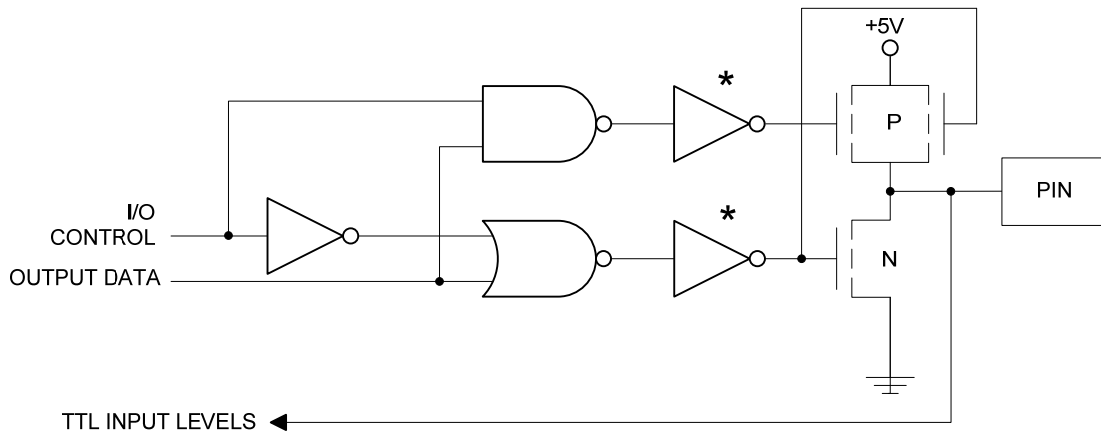


Figure 3-7 Rockwell – R65NC22 CMOS Port A Buffer (PA0-PA7, CA2)

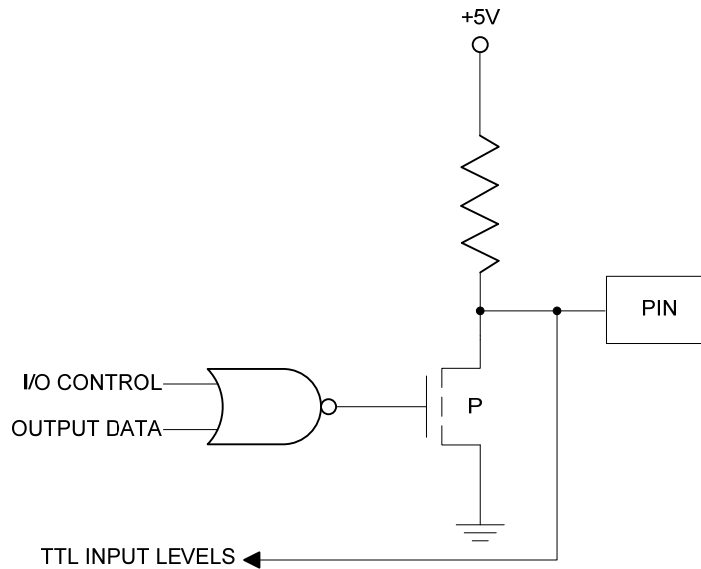


Figure 3-8 Rockwell – R6522 NMOS Port A Buffer (PA0-PA7, CA2)

3.7 Peripheral Data Port B (PB0-PB7)

PB is an 8 line, bidirectional bus which is controlled by an ORA, IRB, and DDRB in a manner much the same as PA. With respect to PB, the output signal on line PB7 may be controlled by Timer 1 while Timer 2 may be programmed to count pulses on the PB6 line. The W65C22S PB lines represent one CMOS high impedance load with bus holding device in the input mode and will drive two TTL loads in the output mode. PB lines are also capable of sourcing 3.0 mA at 1.5 V in the output mode. This allows the output to directly drive Darlington transistor circuits. Note that the W65C22S does not have current limiting resistors; however, the W65C22N does have current limiting resistors. See Figures 3-9 through 3-12 for PB schematic comparisons of W65C22N, W65C22S and legacy obsolete versions of the 6522.

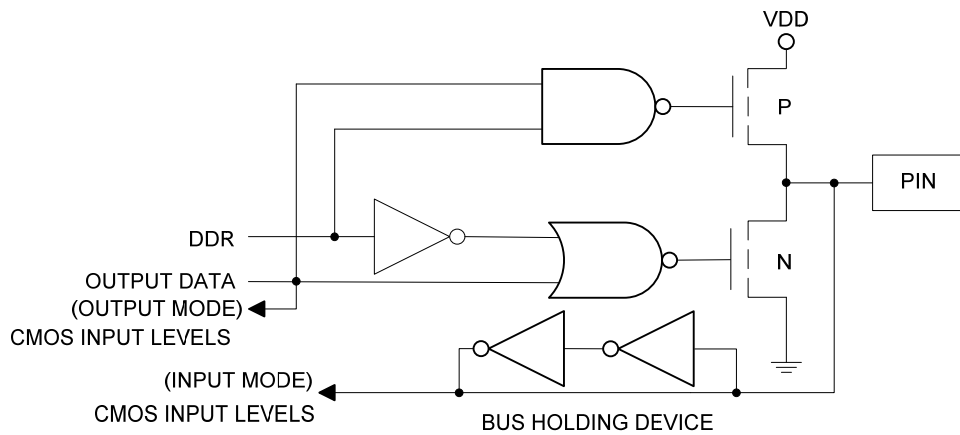


Figure 3-9 W65C22S Port B Buffer (PB0-PB7, CB1, and CB2)

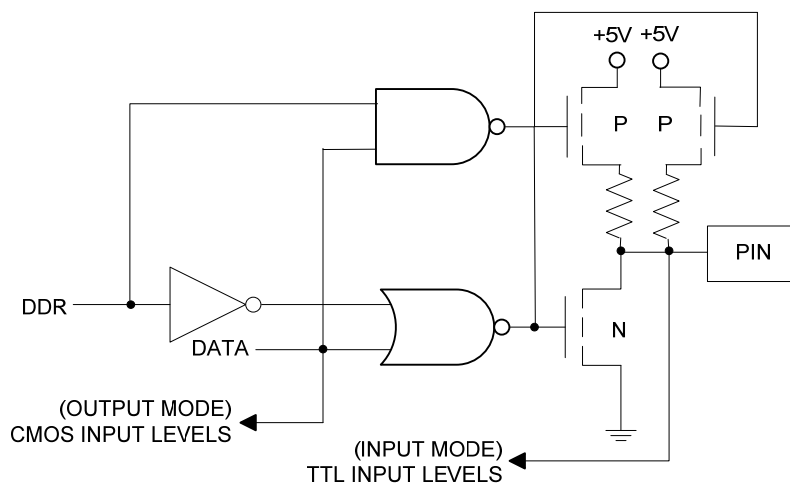


Figure 3-10 W65C22N and GTE - G65SC22 CMOS Port B Buffer (PB0-PB7, CB1, and CB2)

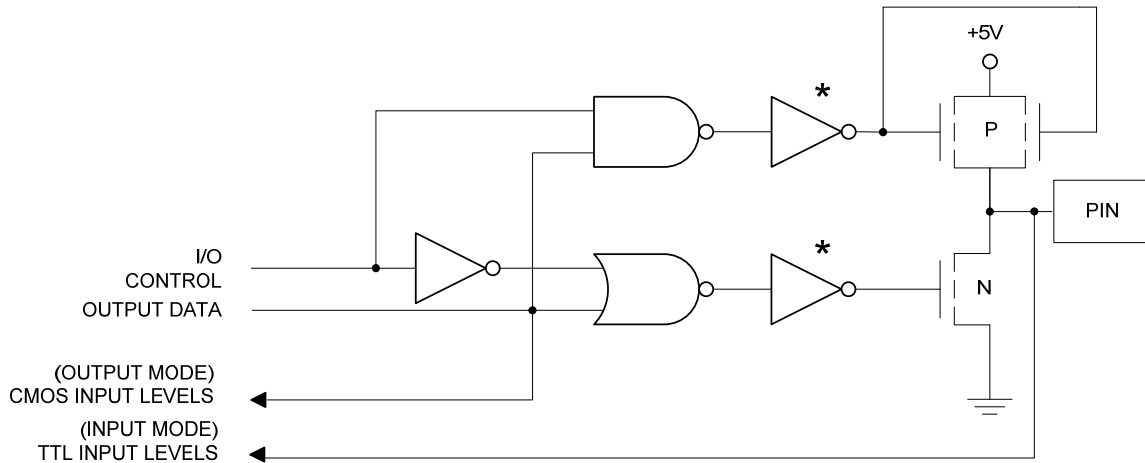


Figure 3-11 Rockwell - R65NC22 (CMOS), R6522 (NMOS) Port B Buffers (PB0-PB7)

* Note: The Rockwell Data Book / Data Sheet has these inverters; however the buffers are really like the G65SC22 buffers we think this is a schematic mistake.

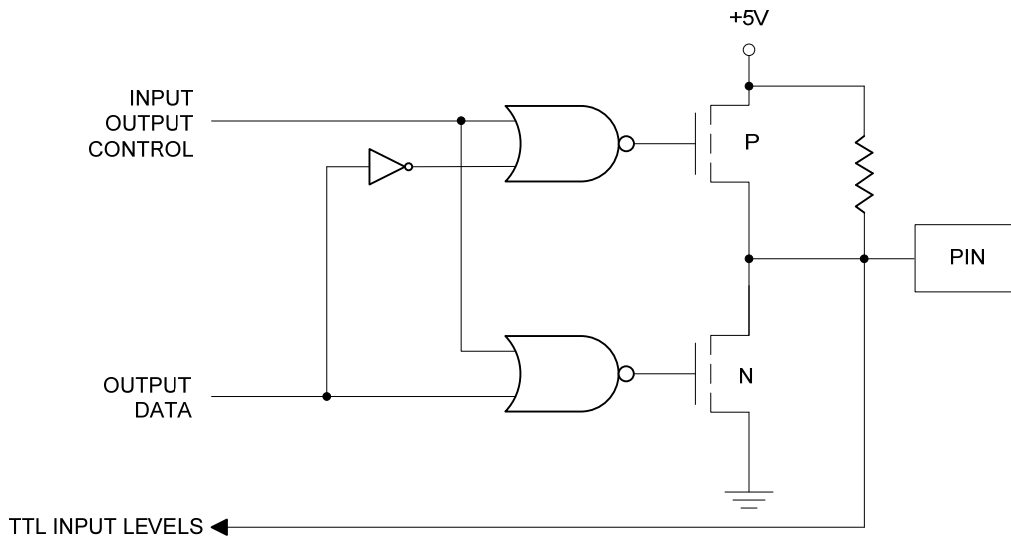


Figure 3-12 Rockwell – R65NC22 (CMOS), R6522 NMOS - CB1, and CB2 Buffer



3.8 Phase 2 Internal Clock (PHI2)

The system PHI2 Input Clock controls all data transfers between the W65C22 and the microprocessor.

3.9 Reset (RESB)

Reset clears all internal registers (except T1 and T2 counters and latches, and the SR. In the RESB condition, all pins are placed in the input state and bus holding devices maintain initial level if not driven. The initial level can be Logic 1 or Logic 0 and are not initialized by on chip circuitry. Also, T1 and T2, SR and the interrupt logic are disabled from operation. All inputs have NOR gates with reset overriding the input pin value. Schmitt trigger NOR gates are on CA1, CA2, DB1, CB2, and PH2. Reset has a Schmitt trigger inverter input. The W65C22S RESB input has a bus holding device.

3.10 Register Select (RS0-RS3)

The RS0-RS3 inputs allow the microprocessor to select one of 16 internal registers within the W65C22. Refer to Table 1 for Register Select coding and a functional description. The W65C22S RS0-RS3 pins have bus holding devices.

3.11 RWB (Read/Write)

The RWB signal is generated by the microprocessor and is used to control the transfer of data between the W65C22 and the microprocessor. When RWB is at a Logic 1 and the chip is selected, data is transferred from the W65C22 to the microprocessor (Read operation). Conversely, when RWB is at logic 0, data is transferred from the processor to the selected W65C22 register (Write operation). RWB must always be preceded by a proper level on CS1, CS2B. The W65C22S RWB pin has a bus holding device.

3.12 VDD and VSS

VDD is the positive supply voltage and VSS is system logic ground.



4. TIMING, AC AND DC CHARACTERISTICS

4.1 W65C22 Absolute Maximum Ratings

Table 4-1 Absolute Maximum Ratings

Rating	Symbol	Value
Supply Voltage	VDD	-0.3 to +7.0V
Input Voltage	VIN	-0.3 to VDD +0.3V
Storage Temperature	TS	-55°C to +150°C

This device contains input protection against damage due to high static voltages or electric fields; however, precautions should be taken to avoid application of voltages higher than the maximum rating.

Note: Exceeding these ratings may result in permanent damage. Functional operation under these conditions is not implied.



4.2 DC Characteristics TA= -40°C to +85°C

Table 4-2a W65C22N DC Characteristics

Symbol	Parameter	5.0 +/-5%		Units
		Min	Max	
VDD	Supply Voltage	4.75	5.25	V
Vih	Input High Voltage, All inputs (VDD=MAX)	2.0	VDD+0.3	V
Vil	Input Low Voltage, All inputs (VDD=MIN)	-0.3	0.8	V
Iin	Input Leakage Current, Vin = 0.4V to 2.4V (VDD=MAX)	-20	20	nA
Iih	Input High Current Vin = 2.4V (VDD=MIN) PA0-PA7, PB0-PB7, CA2, CB1, CB2	-200		uA
Iil	Input Low Current Vin = 0.4V (VDD=MAX) PA0-PA7, PB0-PB7, CA2, CB1, CB2		1.6	mA
Vol	Output Low Voltage (VDD=MIN) (Iol=3.2mA) All outputs PA0-PA7, PB0-PB7, CA2, CB1, CB2, DB0-DB7, IRQB		0.4	V
Voh	Output High Voltage (VDD=MIN) (Ioh=200uA) (VDD=MIN) All outputs	2.4	-	V
Ioh	Output High Current (Sourcing) (Voh=1.5V) (VDD=MIN) PB0-PB7	-3.0		mA
Idd	Supply Current (With tester loading) (1) Supply Current (CORE) (1)	-	0.5 0.2	mA/ MHz
Cin*	Input Capacitance, f = 1 MHz	-	5.0	pF
Cout*	Output Capacitance, f = 1 MHz	-	5.0	pF

Table 4-2b W65C22S DC Characteristics

Symbol	Parameter	5.0 +/-10%		3.3+/-10%		3.0+/-5%		2.5+/-5%		1.8+/-5%		Units
		Min	Max	Min	Max	Min	Max	Min	Max	Min	Max	
VDD	Supply Voltage	4.5	5.5	2.97	3.63	2.85	3.15	2.37	2.63	1.71	1.89	V
Vih	Input High Voltage - All inputs	VDDx0.8	VDD+0.3	VDDx0.7	VDD+0.3	VDDx0.7	VDD+0.3	VDDx0.7	VDD+0.3	VDDx0.7	VDD+0.3	V
Vil	Input Low Voltage - All inputs	VSS-0.3	VDDx0.2	VSS-0.3	VSSx0.3	VSS-0.3	VDDx0.3	VSS-0.3	VDDx0.3	VSS-0.3	VDDx0.3	V
Iin	Input Leakage Current, Vin = VDD(MAX)x0.2 to VDD(MAX)x0.8 For PHI2	-100	100	-20	20	-20	20	-20	20	-20	20	nA
Iinh	Input Bus Holding Current Vin = VDD(MIN)x0.8 All pins except PHI2,IRQB,VDD,VSS	-3	-9	-4	-7	-4	-6	-1	-3	-1.5	-2	uA
Iinl	Input Bus Holding Current Vin = VDD(MAX)x0.2 All pins except PHI2,IRQB,VDD,VSS	8	20	6	9	4	7	3.5	5	.5	1.5	uA
Iol	Output Low Current (Vol = 0.4v)(VDD=MIN) All outputs	3.2	-	1.6	-	1.6	-	1.0	-	0.5	-	mA
Ioh	Output High Current (Voh=VDD-0.4v) (VDD=MIN) All outputs	-3.2mA	-	.350	-	.300	-	.200	-	.100	-	mA
Ioh	Output High Current (Sourcing) Voh=1.5V Direct Transistor Drive - All outputs	-3.0	-100.0 (2)	-3.0	-10.0 (3)	-2.0	-7.0 (3)	-1.5	-5.0 (3)	-1.0	-4.0 (3)	mA
Idd	Supply Current (With tester loading) (1) Supply Current (CORE) (1)	-	0.5 0.2	-	0.4 0.15	-	0.35 0.125	-	0.3 0.10	-	0.25 0.08	mA/ MHz
Cin*	Input Capacitance, f = 1 MHz	-	5.0	-	5.0	-	5.0	-	5.0	-	5.0	pF
Cout*	Output Capacitance, f = 1 MHz	-	5.0	-	5.0	-	5.0	-	5.0	-	5.0	pF

Notes: 20100527 DC Characteristics updated for HiLevel Production Testing

* These are estimated characteristics. –

(1) These are estimated power characteristics.

(2) PAX and PBx are high drive. Use external current limiting resistors for W65C22S. W65C22N has built in current limiting resistors.

(3) These are estimated characteristics. Special testing available upon request for a fee.

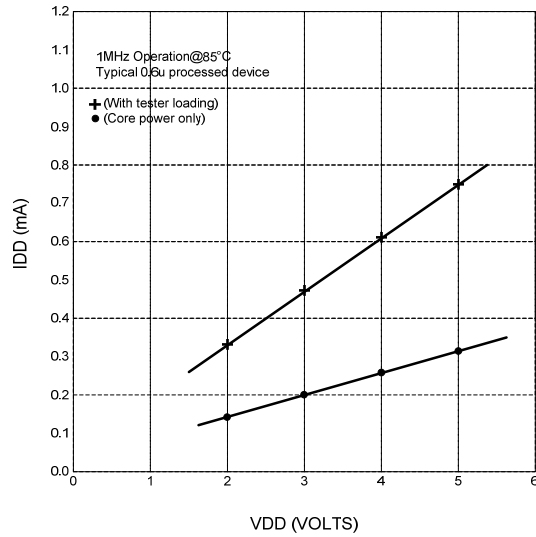


Figure 4-1a W65C22N IDD vs. VDD

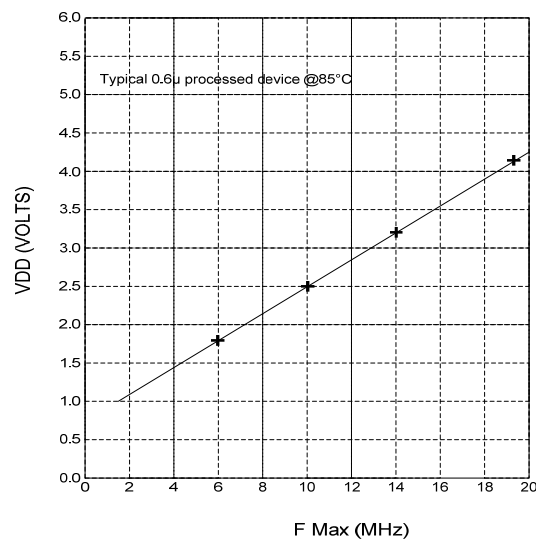


Figure 4-2a W65C22N F Max vs. VDD



THE WESTERN DESIGN CENTER, INC.

W65C22 Data Sheet



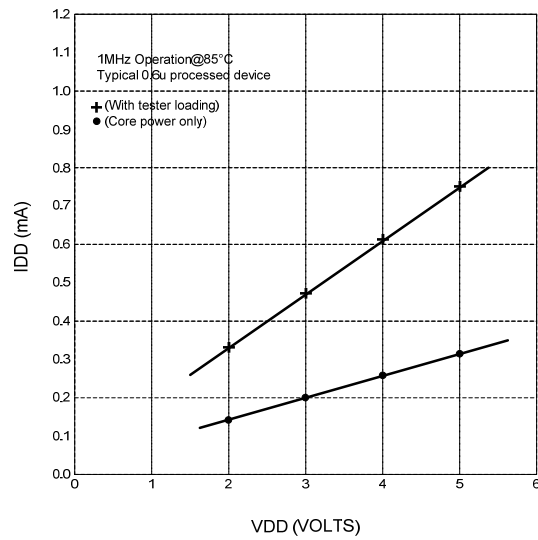


Figure 4-1b W65C22S IDD vs. VDD

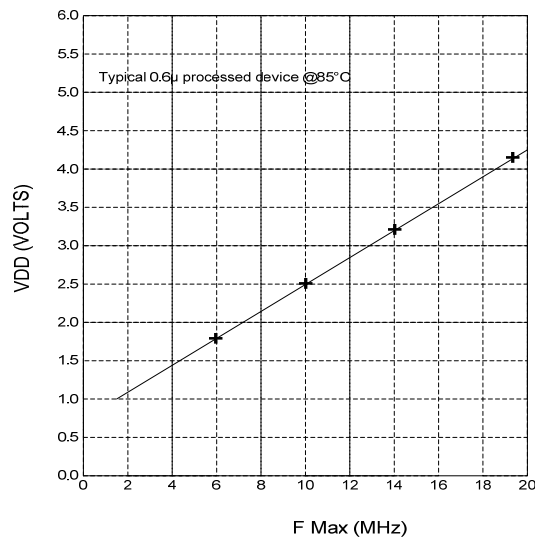


Figure 4-2b W65C22S F Max vs. VDD



4.3 AC Characteristic TA=-40°C to +85°C

Table 4-3a W65C22N AC Characteristics
Processor Interface Timing

Symbol	Parameter	5.0+/-5%		Units
		Min	Max	
		14 MHz		
tCYC	Cycle Time	70	-	nS
tPWH	Phase 2 Pulse Width High	35	-	nS
tPWL	Phase 2 Pulse Width Low	35	-	nS
tR,F	Phase 2 Transition	-	5	nS
tACR	CSx, RSx, RWB Setup - READ	10	-	nS
tCAR	CSx, RSx, RWB Hold (PHI2 rising edge) - READ	10	-	nS
tCDR	Data Bus Delay	-	20	nS
tHR	Data Bus Hold Time	10	-	nS
tPCR	Peripheral Data Setup	10	-	nS
tACW	CSx, RSx, RWB Setup - WRITE	10	-	nS
tCAW	CSx, RSx, RWB Hold (PHI2 rising edge) - WRITE	10	-	nS
tDC W	Data Bus Setup	10	-	nS
tHW	Data Bus Hold	10	-	nS
tCPW	Peripheral Data Delay	-	250	nS



Table 4-3b W65C22S AC Characteristics
Processor Interface Timing

Symbol	Parameter	5.0+/-5%		3.3 +/-10%		3.0+/-5%		2.5+/-5%		1.8+/-5%		Units
		Min	Max	Min	Max	Min	Max	Min	Max	Min	Max	
		14 MHz		10 MHz		8 MHz		4 MHz		2MHz		
tCYC	Cycle Time	70	-	100	-	125	-	250	-	500	-	nS
tPWH	Phase 2 Pulse Width High	35	-	50	-	62	-	125	-	250	-	nS
tPWL	Phase 2 Pulse Width Low	35	-	50	-	63	-	125	-	250	-	nS
tR,F	Phase 2 Transition	-	5	-	5	-	5	-	5	-	5	nS
tACR	CSx, RSx, RWB Setup - READ	10	-	10	-	10	-	20	-	40	-	nS
tCAR	CSx, RSx, RWB Hold (PHI2 rising edge) - READ	10	-	10	-	10	-	10	-	10	-	nS
tCDR	Data Bus Delay	-	20	-	25	-	35	-	80	-	180	nS
tHR	Data Bus Hold Time	10	-	10	-	10	-	10	-	10	-	nS
tPCR	Peripheral Data Setup	10	-	10	-	30	-	60	-	120	-	nS
tACW	CSx, RSx, RWB Setup - READ	10	-	10	-	10	-	20	-	90	-	nS
tCAW	CSx, RSx, RWB Hold (PHI2 rising edge) - READ	10	-	10	-	10	-	10	-	10	-	nS
tDCW	Data Bus Setup	10	-	10	-	10	-	20	-	40	-	nS
tHW	Data Bus Hold	10	-	10	-	10	-	10	-	10	-	nS
tCPW	Peripheral Data Delay	-	30	-	50	-	60	-	120	-	240	nS



Table 4-4a W65C22N AC
Peripheral Interface Timing

Symbol	Parameter	5.0+/-5%		Units	Figure
		Min	Max		
		14 MHz			
tR, tF	Rise & Fall Time for CA1, CB1, CA2 and CB2 Input Signals	-	70	nS	-
tCA2	Delay Time, Clock Negative Transition to CA2 Negative Transition (Read Handshake or Pulse Mode)	-	75	nS	4-3 4-4
tRS1	Delay Time, Clock Negative Transition to CA2 Positive Transition (Pulse Mode)	-	75	uS	4-3
tRS2	Delay Time, CA1 Active Transition to CA2 Positive Transition (Read Handshake Mode)	-	100	nS	4-4
tWHS	Delay Time, Clock Positive Transition to CA2 or CB2 Negative Transition (Write Handshake)	-	75	nS	4-5 4-6
tDS	Delay Time, Peripheral Data Valid to CB2 Negative Transition	-	100	nS	4-5 4-6
tRS3	Delay Time, Clock Positive Transition to CA2 or CB2 Positive Transition (Write Pulse Mode)	-	150	nS	4-5
tRS4	Delay Time, CA1 or CB1 Active Transition to CA2 or CB2 Positive Transition (Handshake Mode)	-	88	ns	4-6
t21	Delay Time Required from CA2 Output to CA1 Active Transition (Write Handshake Mode)	-	88	nS	4-6
tIL	Set-up Time, Peripheral Data Valid to CA1 or CB1 Active Transition (Input Latching)	62	-	nS	4-7
tSR1	Shift-Out Delay Time - Time from PHI2 Falling Edge to CB2 Data Out	-	35	nS	4-8
tSR2	Shift-In Set-up Time - Time from CB2 Data in to PHI2 Rising Edge	105	-	nS	4-9
tSR3	External Shift Clock (CB1) Set-up Time Relative to PHI2 Trailing Edge	0	tCYC	nS	4-9
tIPW	Pulse Width - PB6 Input Pulse	2x tCYC	-	nS	4-11
tICW	Pulse Width - CB1 Input Clock	2x tCYC	-	nS	4-10
tIPS	Pulse Spacing - PB6 Input Pulse	2x tCYC	-	nS	4-11
tICS	Pulse Spacing - CB1 Input Pulse	2x tCYC	-	nS	4-10
tAL	CA1, CB1 Set Up Prior to Transition to Arm Latch	88	-	nS	4-7
tPDH	Peripheral Data Hold after CA1, CB1 Transition	10	-	nS	4-7

Note: See Figure 4-12 for test load



Table 4-4b W65C22S AC
Peripheral Interface Timing

Symbol	Parameter	5.0+/-5%		3.3 +/-10%		3.0+/-5%		2.5+/-5%		1.8+/-5%		Units	Figure
		Min	Max	Min	Max	Min	Max	Min	Max	Min	Max		
		14 MHz		10 MHz		8 MHz		4 MHz		2 MHz			
tR, tF	Rise & Fall Time for CA1, CB1, CA2 and CB2 Input Signals	-	70	-	100	-	125	-	250	-	500	nS	-
tCA2	Delay Time, Clock Negative Transition to CA2 Negative Transition (Read Handshake or Pulse Mode)	-	75	-	105	-	130	-	255	-	505	nS	4-3 4-4
tRS1	Delay Time, Clock Negative Transition to CA2 Positive Transition (Pulse Mode)	-	75	-	105	-	130	-	255	-	505	uS	4-3
tRS2	Delay Time, CA1 Active Transition to CA2 Positive Transition (Read Handshake Mode)	-	100	-	135	-	160	-	285	-	535	nS	4-4
tWHS	Delay Time, Clock Positive Transition to CA2 or CB2 Negative Transition (Write Handshake)	-	75	-	105	-	130	-	255	-	505	nS	4-5 4-6
tDS	Delay Time, Peripheral Data Valid to CB2 Negative Transition	-	100	-	135	-	160	-	285	-	535	nS	4-5 4-6
tRS3	Delay Time, Clock Positive Transition to CA2 or CB2 Positive Transition (Write Pulse Mode)	-	150	-	220	-	270	-	520	-	1020	nS	4-5
tRS4	Delay Time, CA1 or CB1 Active Transition to CA2 or CB2 Positive Transition (Handshake Mode)	-	88	-	125	-	160	-	285	-	535	ns	4-6
t21	Delay Time Required from CA2 Output to CA1 Active Transition (Write Handshake Mode)	-	88	-	125	-	160	-	285	-	535	nS	4-6
tIL	Set-up Time, Peripheral Data Valid to CA1 or CB1 Active Transition (Input Latching)	62	-	92	-	115	-	240	-	490	-	nS	4-7
tSR1	Shift-Out Delay Time - Time from PHI2 Falling Edge to CB2 Data Out	-	35	-	43	-	70	-	130	-	260	nS	4-8
tSR2	Shift-In Set-up Time - Time from CB2 Data in to PHI2 Rising Edge	105	-	155	-	195	-	380	-	780	-	nS	4-9
tSR3	External Shift Clock (CB1) Set-up Time Relative to PHI2 Trailing Edge	0	tCYC	0	tCYC	0	tCYC	0	tCYC	0	tCYC	nS	4-9
tIPW	Pulse Width - PB6 Input Pulse	2x tCYC	-	2x tCYC	-	2x tCYC	-	2x tCYC	-	2x tCYC	-	nS	4-11
tICW	Pulse Width - CB1 Input Clock	2x tCYC	-	2x tCYC	-	2x tCYC	-	2x tCYC	-	2x tCYC	-	nS	4-10
tIPSP	Pulse Spacing - PB6 Input Pulse	2x tCYC	-	2x tCYC	-	2x tCYC	-	2x tCYC	-	2x tCYC	-	nS	4-11
tICSP	Pulse Spacing - CB1 Input Pulse	2x tCYC	-	2x tCYC	-	2x tCYC	-	2x tCYC	-	2x tCYC	-	nS	4-10
tAL	CA1, CB1 Set Up Prior to Transition to Arm Latch	88	-	125	-	150	-	300	-	600	-	nS	4-7
tPDH	Peripheral Data Hold after CA1, CB1 Transition	10	-	20	-	20	-	20	-	20	-	nS	4-7

Note: See Figure 4-12 for test load



4.4 Timing Diagrams

Note: Measurement points are at 50% of VDD unless otherwise specified.

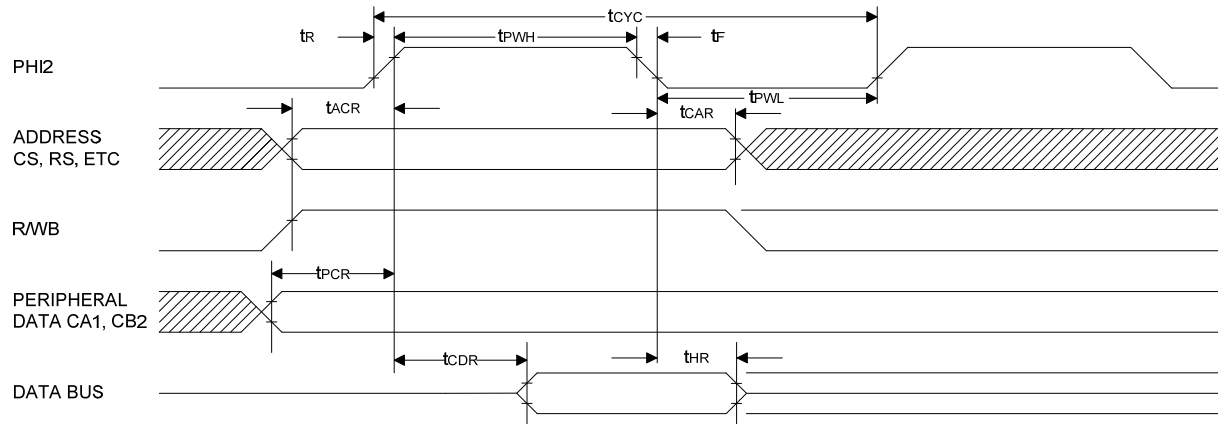


Figure 4-1 Read Timing

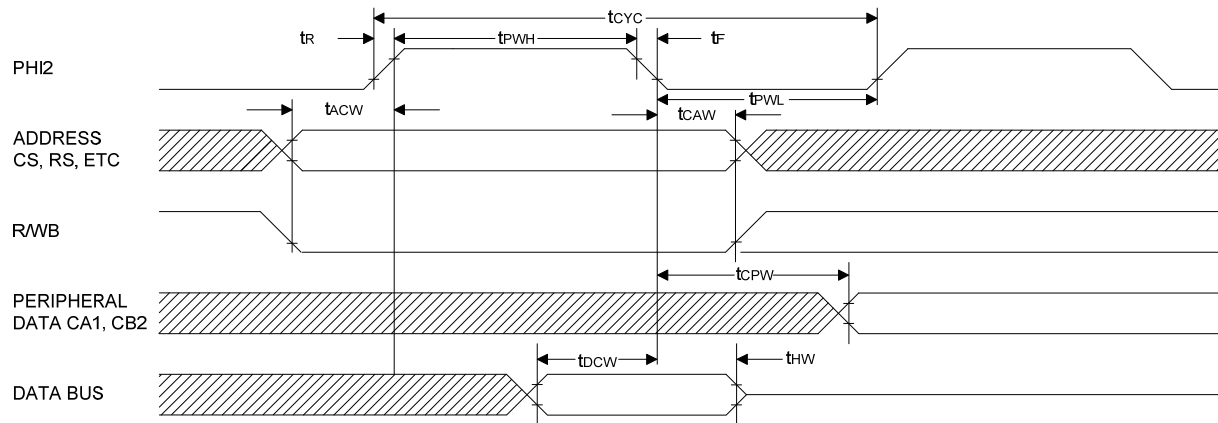


Figure 4-2 Write Timing

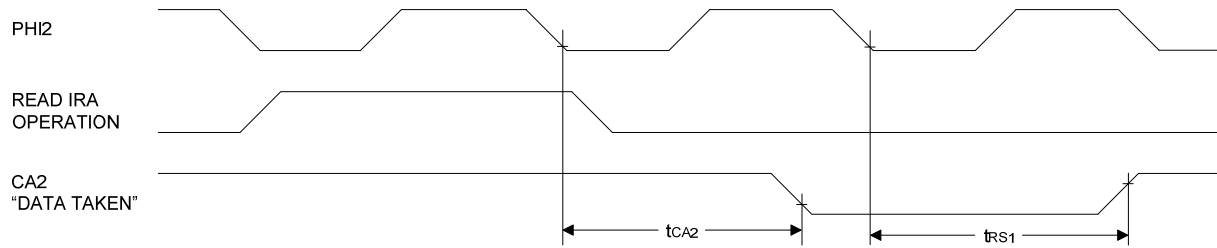


Figure 4-3 Read Handshake, Pulse Mode (CA2)

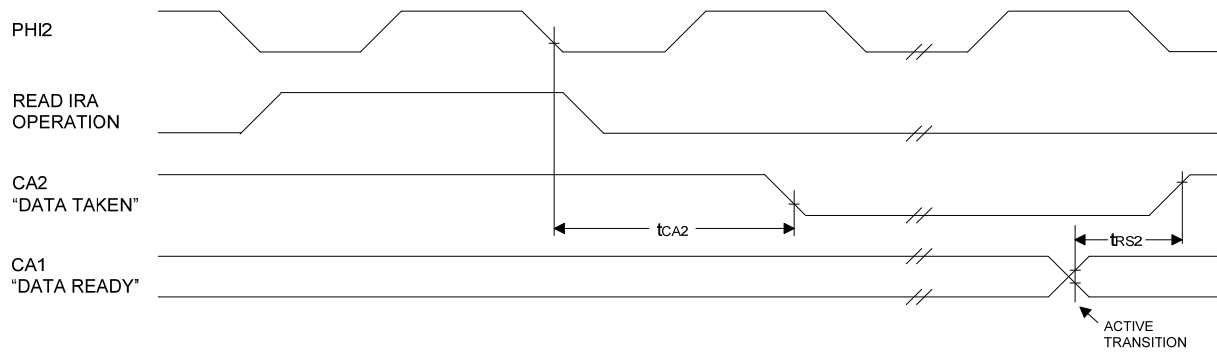


Figure 4-4 Read Handshake, Handshake Mode Timing (CA2)

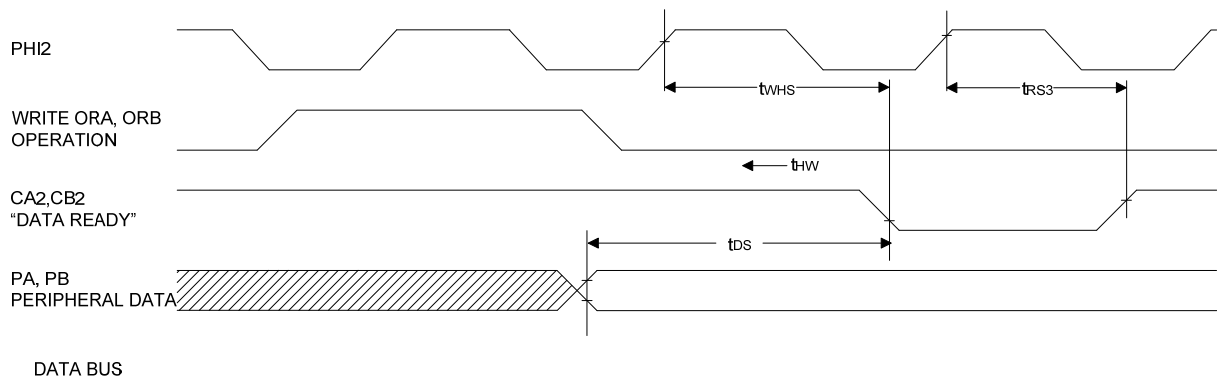


Figure 4-5 Write Handshake, Pulse Mode Timing (CA2, CB2)

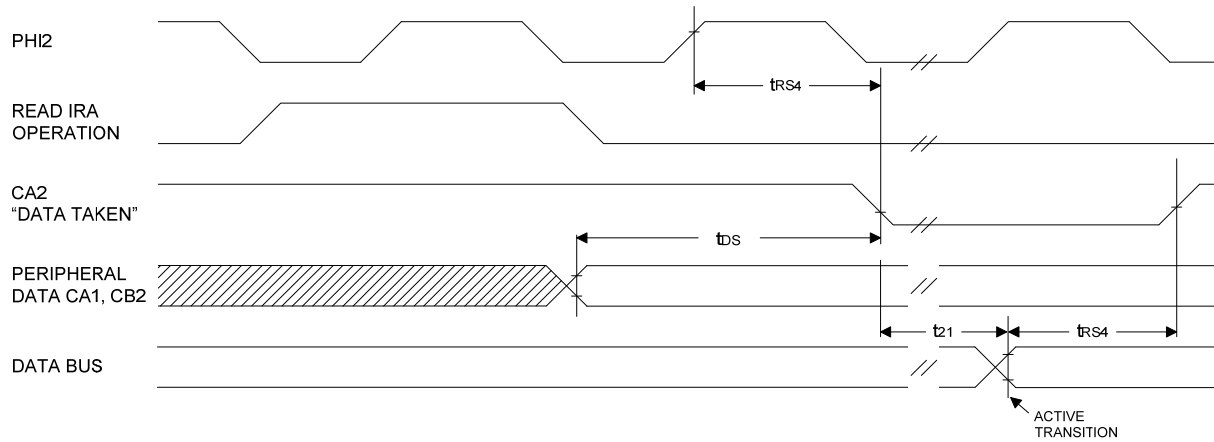


Figure 4-6 Write Handshake, Handshake Mode Timing (CA2, CB2)

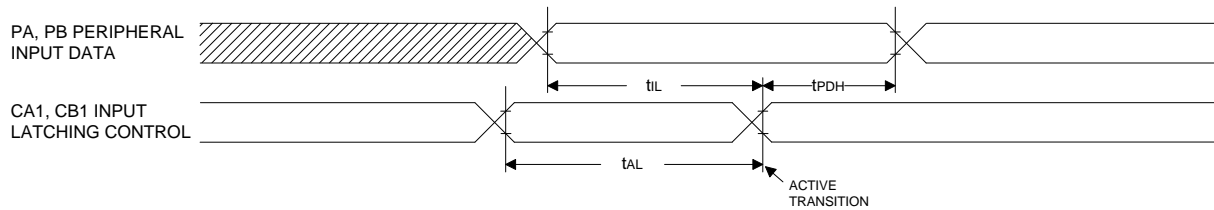


Figure 4-7 Peripheral Data, Input Latching Timing

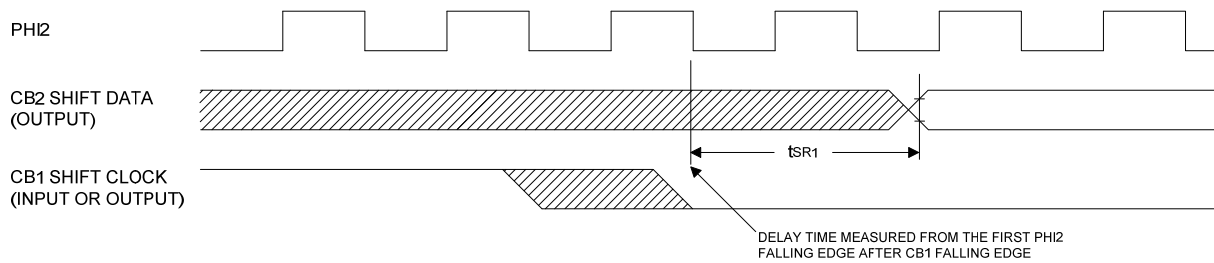


Figure 4-8 Data Shift Out, Internal or External Shift Clock Timing

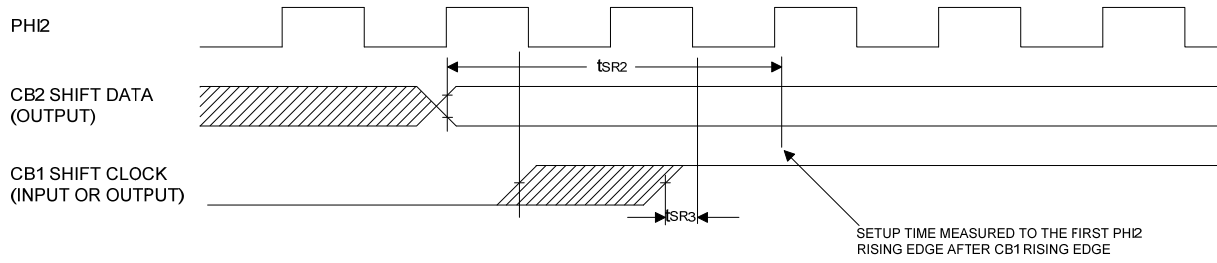


Figure 4-9 Data Shift In, Internal or External Shift Clock Timing

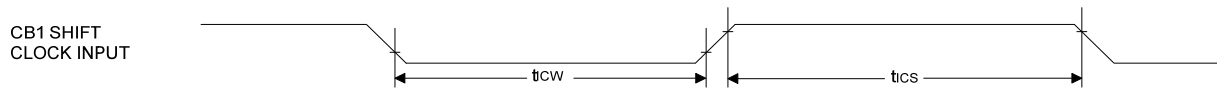


Figure 4-10 External Shift Clock Timing

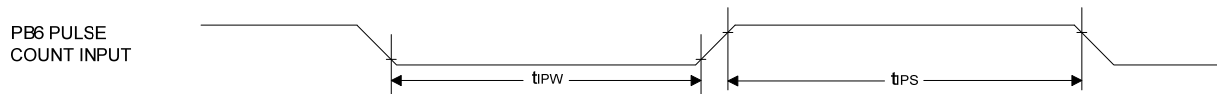


Figure 4-11 Pulse Count Input Timing

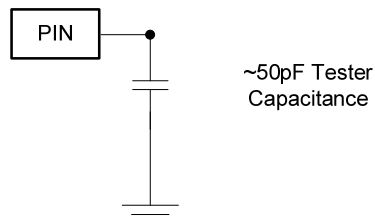


Figure 4-12 Test Load (All Dynamic Parameters)



5. CAVEATS

5.1 Older Versions

On older versions of the 6522 and 65C22, which are not internally chip selected, random register are read due to register select values. The W65C22 selects only register 15 (\$F) internally. This feature has been added for systems which have indeterminate register select values.

5.2 Shift Clock

When outputting the Shift Clock, the CB1 pin may be overdriven without affecting the shifting function. However, this is not recommended as it will result in high currents and possible damage to the part. Because some systems have been arbitrating the clock after data has been transferred, this feature was added.

5.3 Bus Holding Pins

All W65C22S pins except PHI2 have bus holding devices. The original NMOS 6522, W65C22N, G65SC22, and R65NC22 did not have bus holding devices.

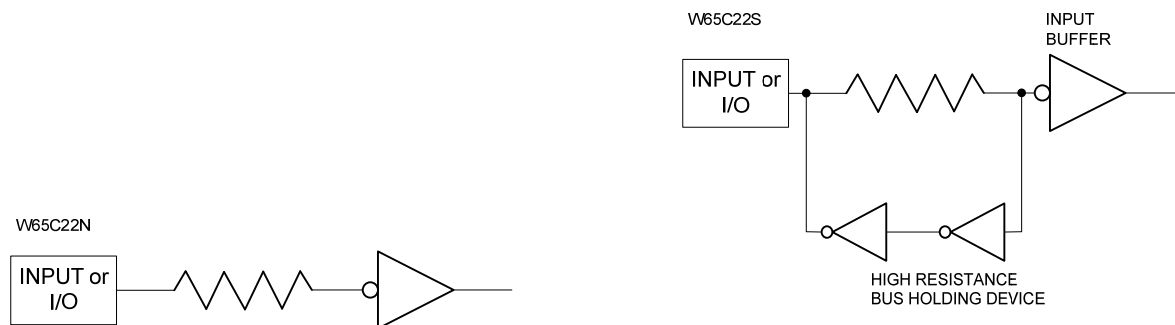


Figure 5-1 High Resistance Bus Holding Device on the W65C22S

5.4 Current Limiting

The W65C22S output pins do not have current limiting and can over drive circuitry connected to these pins. The original NMOS 6522 and W65C22N have current limiting resistors in series with PB and PA outputs.



6. HARD CORE MODEL

6.1 W65C22C vs. W65C22S

The W65C22C is functionally equivalent to the W65C22S except it does not have the output drive transistors and does not have ESD protection.

6.2 Chip Select

If Chip Select, CS1 is not used, it should be held in the high state. If Chip Select, CS2B, is not used it should be held in the low state.

6.3 W65C22C and W65C22S Timing

The timing of the W65C22C is the same as the W65C22S in that the input buffers are the same and the output transistor drivers are the same as the W65C22S. When applying the W65C22S core, the output delays should be analyzed after adding the output drive transistors and the output load capacitance.



7. ORDERING INFORMATION

Example: W65C22N6TPLG-14	
Description W65C = standard product	W65C
Product Identification Number 22N = NMOS Compatible 22S = Standard CMOS	22N
Foundry Process 6T = 0.6u TSMC Process	6T
Package P = Plastic Dual-In-Line, 40 pins PL = Plastic Leaded Chip Carrier, 44 pins	PL
RoHS/Green Compliance G = RoHS/Green Compliant (Wafer and Packaging)	G
Temperature/Processing Blank = -40°C to + 85°C	
Speed Designator -14 = 14MHz	-14

To receive general sales or technical support on standard product or information about our module library licenses, contact us at:

The Western Design Center, Inc.
2166 East Brown Road
Mesa, Arizona 85213 USA
Phone: 480-962-4545 Fax: 480-835-6442
Info@WesternDesignCenter.com
www.WesternDesignCenter.com

WARNING: MOS CIRCUITS ARE SUBJECT TO DAMAGE FROM STATIC ELECTRICAL CHARGE BUILDUPS. Industry established recommendations for handling MOS circuits include:

1. Ship and store product in conductive shipping tubes or conductive foam plastic. Never ship or store product in non-conductive plastic containers or non-conductive plastic foam material.
2. Handle MOS parts only at conductive work stations.
3. Ground all assembly and repair tools.