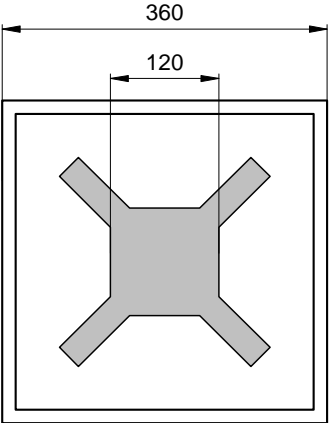

Radiation	Type	Technology	Electrodes
Infrared	DDH	AlGaAs/AlGaAs	P (anode) up

 <p style="text-align: center;">LED-05</p>	typ. dimensions (μm)	
	<u>typ. thickness</u> 150 (±25) μm <u>anode</u> gold alloy, 1.5 μm <u>cathode</u> gold alloy, 0.5 μm structured, 25% covered	

Maximum Ratings

$T_{amb} = 25^{\circ}\text{C}$, unless otherwise specified

Parameter	Test conditions	Symbol	Min	Typ	Max	Unit
Forward current (DC)		I_F			50	mA

Optical and Electrical Characteristics

$T_{amb} = 25^{\circ}\text{C}$, unless otherwise specified

Parameter	Test conditions	Symbol	Min	Typ	Max	Unit
Forward voltage	$I_F = 20 \text{ mA}$	V_F	1.15	1.3	1.5	V
Reverse voltage	$I_R = 100 \text{ μA}$	V_R	5			V
Radiant power ¹	$I_F = 20 \text{ mA}$	Φ_e	2	3		mW
Peak wavelength	$I_F = 20 \text{ mA}$	λ_p	900	910	915	nm
Spectral bandwidth at 50%	$I_F = 20 \text{ mA}$	$\Delta\lambda_{0.5}$	50	60	70	nm
Switching time	$I_F = 20 \text{ mA}$	t_r, t_f		50	100	ns

¹Measured on bare chip on TO-18 header with JENOPTIK Polymer Systems equipment

Labeling

Type	Lot N°	$\Phi_e(\text{typ})$ [mW]	$V_F(\text{typ})$ [V]	Quantity
ELC-910-17				

Packing: Chips on adhesive film with wire-bond side on top