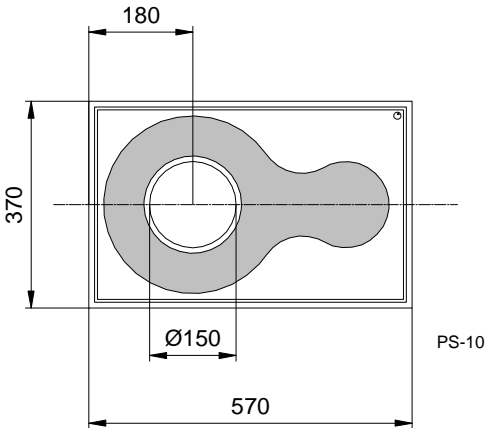

Radiation	Type	Technology	Electrodes
Infrared	Point Source	AlGaAs/GaAs	P (anode) up

	typ. dimensions (μm)
	<u>typ. thickness</u> 260 (±20) μm <u>cathode</u> gold alloy, 0.5 μm <u>anode</u> gold alloy, 1.5 μm

Maximum Ratings

T_{amb} = 25°C, unless otherwise specified

Parameter	Test conditions	Symbol	Min	Typ	Max	Unit
Forward current (DC)		I _F			100	mA
Peak forward current	t _p ≤ 50 μs, t _p /T = 1/2	I _{FM}			200	mA

Optical and Electrical Characteristics

T_{amb} = 25°C, unless otherwise specified

Parameter	Test conditions	Symbol	Min	Typ	Max	Unit
Forward voltage	I _F = 20 mA	V _F		1.3	1.5	V
Forward voltage	I _F = 100 mA	V _F		1.5	1.9	V
Reverse voltage	I _R = 10 μA	V _R	5			V
Radiant power*	I _F = 20 mA	Φ _e	0.6	0.8		mW
Radiant power*	I _F = 100 mA	Φ _e	4.0	5.5		mW
Peak wavelength	I _F = 20 mA	λ _p	865	875	885	nm
Spectral bandwidth at 50%	I _F = 20 mA	Δλ _{0.5}		40		nm
Switching time	I _F = 20 mA	t _r , t _f		16		ns

*Measured on bare chip on TO-18 header with JENOPTIK Polymer Systems equipment

Labeling

Type	Lot N°	Φ _e (typ) [mW]	V _F (typ) [V]	Quantity
ELC-875-19-50				

Packing: Chips on adhesive film with wire-bond side on top

We reserve the right to make changes to improve technical design and may do so without further notice.

Parameters can vary in different applications. All operating parameters must be validated for each customer application by the customer.

JENOPTIK Polymer Systems GmbH, D-12555 Berlin, Köpenicker Str.325 b, Haus 201

Tel.: +49-30-6576 2543, Fax : +49-30-6576 2545