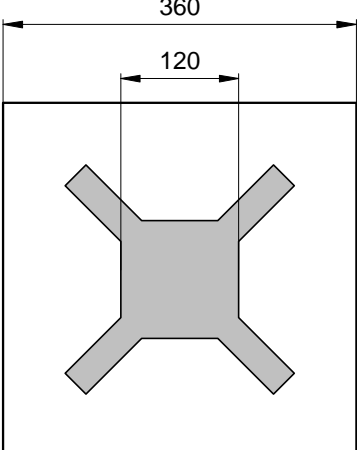

Radiation	Type	Technology	Electrodes
Infrared	DDH	AlGaAs/AlGaAs	N (cathode) up

 <p style="text-align: center;">LED-14</p>	typ. dimensions (μm)	
	<u>typ. thickness</u> 150 (±25) μm <u>cathode</u> gold alloy, 1.5 μm <u>anode</u> gold alloy, 0.5 μm structured, 25% covered	

Optical and Electrical Characteristics

T_{amb} = 25°C, unless otherwise specified

Parameter	Test conditions	Symbol	Min	Typ	Max	Unit
Forward voltage	I _F = 20 mA	V _F		1.9	2.3	V
Reverse voltage	I _R = 100 μA	V _R	5			V
Radiant power ¹	I _F = 20 mA	Φ _e	2.2	2.7		mW
Radiant power ²	I _F = 20 mA	Φ _e		5.0		mW
Peak wavelength	I _F = 20 mA	λ _p	730	740	750	nm
Spectral bandwidth at 50%	I _F = 20 mA	Δλ _{0.5}		30		nm
Switching time	I _F = 20 mA	t _r , t _f		40		ns

¹Measured on bare chip on TO-18 header with JENOPTIK Polymer Systems equipment

²Measured on epoxy covered chip on TO-18 header with JENOPTIK Polymer Systems equipment

Labeling

Type	Lot N°	Φ _e (typ) [mW]	V _F (typ) [V]	Quantity
ELC-740-27				

Packing: Chips on adhesive film with wire-bond side on top