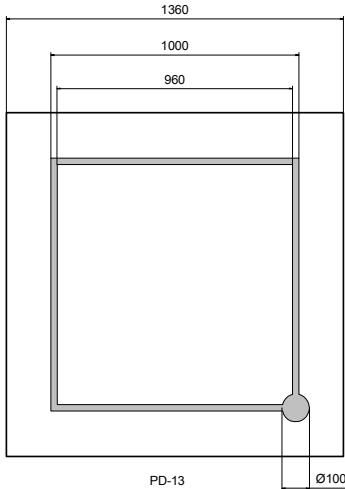

Wavelength range	Type	Technology	Electrodes
Infrared, selective	Integrated filter	AlGaAs/GaAs	P (anode) up

	typ. dimensions (μm)	
	<u>typ. thickness</u> 300 μm <u>anode</u> gold alloy, 1.5 μm <u>cathode</u> gold alloy, 0.5 μm	Description Infrared-selective photo-diode with narrow response range (810 - 950 nm) Applications Optical communications, safety equipment, light barriers

Miscellaneous Parameters

$T_{\text{amb}} = 25^{\circ}\text{C}$, unless otherwise specified

Parameter	Test conditions	Symbol	Value	Unit
Active area		A	1.79	mm^2
Operating temperature range		T_{amb}	-40 to +125	$^{\circ}\text{C}$
Storage temperature range		T_{stg}	-40 to +125	$^{\circ}\text{C}$

Optical and Electrical Characteristics

$T_{\text{amb}} = 25^{\circ}\text{C}$, unless otherwise specified

Parameter	Test conditions	Symbol	Min	Typ	Max	Unit
Dark current	$V_R = 1\text{ V}$	I_D		1.0	2.5	nA
Peak sensitivity	$V_R = 0\text{ V}$	λ_P		890		nm
Spectral range at 50 %	$V_R = 0\text{ V}$	$\lambda_{0.5}$	820		935	nm
Spectral bandwidth at 50%	$V_R = 0\text{ V}$	$\Delta\lambda_{0.5}$		115		nm
Responsivity at λ_P^1	$V_R = 0\text{ V}$	S_λ		0.27		A/W
Switching time	$V_R = 1\text{ V}$	t_r, t_f		200		ns

¹Measured on bare chip on TO-18 header

Labeling

Type	Typ. I_D [pA]	Typ. S_λ [A/W]	Lot N°	Quantity
EPC-880-1.4				

Packing: Chips on adhesive film with wire-bond side on top

*Note: All measurements carried out with *EPIGAP* equipment

We reserve the right to make changes to improve technical design and may do so without further notice.

Parameters can vary in different applications. All operating parameters must be validated for each customer application by the customer.

EPIGAP Optoelektronik GmbH, D-12555 Berlin, Köpenicker Str.325 b, Haus 201

Tel.: +49-30-6576 2543, Fax : +49-30-6576 2545

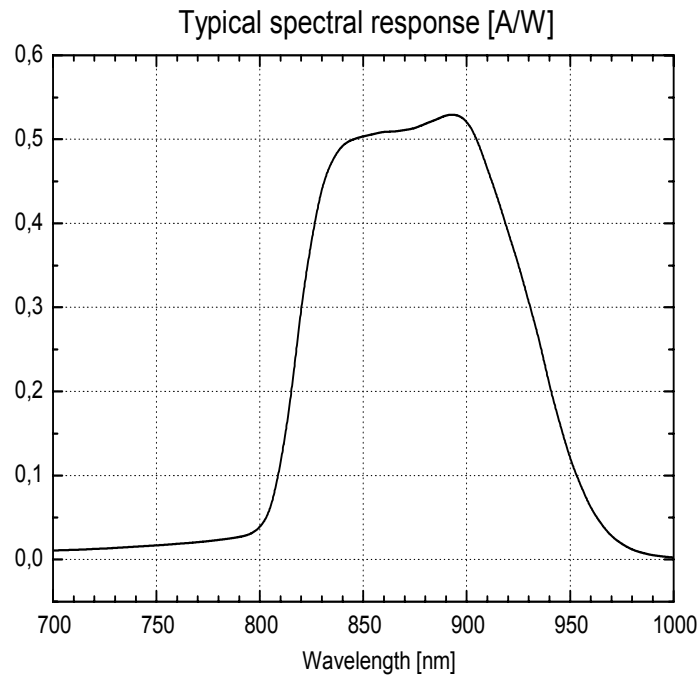

We reserve the right to make changes to improve technical design and may do so without further notice.
Parameters can vary in different applications. All operating parameters must be validated for each customer application by the customer.