



Open Heat Sink Diode Lasers

cw, passively cooled, with collimation, new: 880 nm



JOLD-x-CPBN-1L
JOLD-x-CPFN-1L

Design 215510626
Design 215510126

Features:

- High optical output power up to 90 W cw after collimation
- High efficiency, low divergences
- Long lifetime > 20,000 h, high reliability

Applications:

- Pumping of solid-state lasers
- Print applications
- Medical applications

Open Heat Sink Diode Lasers

cw, passively cooled, with collimation, new: 880 nm

Specifications (Start of Life)

Product	JOLD-50-CPBN-1L, JOLD-68-CPBN-1L Design 215510626					JOLD-72-CPFN-1L, JOLD-90-CPFN-1L Design 215510126			
Operation Mode	cw, power modulation only between threshold and maximum current								
Max. Optical Output Power after Collimation	50	68	68	68	68	72	90	90	W
Center Wavelength at 25 °C	808	880	915	938	976	808	938	976	nm
Center Wavelength Variation at 25 °C	4	4	5	5	5	5	5	5	nm
Typical Spectral Bandwidth (FWHM)	3	3	3	3	3	3	3	3	nm
Maximum Spectral Bandwidth (FWHM)	5	5	5	5	5	5	5	5	nm
Typical Operation Current	59	81	79	79	83	93	112	116	A
Maximum Operation Current	65	91	89	89	93	100	122	126	A
Typical Threshold Current	10	9	6	6	6	19	14	14	A
Maximum Threshold Current	13	12	10	9	9	22	18	18	A
Typical Slope	1.05	0.95	0.95	0.95	0.90	1.00	0.95	0.90	W/A
Minimum Slope	0.90	0.80	0.80	0.80	0.75	0.85	0.80	0.80	W/A
Maximum Operating Voltage	2.0	1.8	1.8	1.8	1.8	2.0	1.8	1.8	V
Fast Axis Divergence (Full Power)	< 0.5	< 0.5	< 0.5	< 0.5	< 0.5	< 0.5	< 0.5	< 0.5	°
Slow Axis Divergence (Full Power)	< 4	< 4	< 4	< 4	< 4				°
Typical Slow Axis Divergence FWHM						6	6	6	°
Typical Slow Axis Divergence 86 %						6	7	7	°
Typical Slow Axis Divergence 95 %						7	8	8	°
Anode, Cathode Connectors	Holes for screws M5, M4								
Operation Conditions	Cleanroom class 100, non-condensing atmosphere								
Expected Lifetime	> 20,000 h (constant current), partly under qualification								
Cooling:	Via thermally conductive foil (thickness 25 ... 100 µm) on cooled surface (water cooled plate or TEC)								
Mounting	Note Do not mount via any paste-like media!								
Operation Temperature	15 ... 30 °C, measured with temperature sensor in heatsink								
	See General User Information!								

Options on request: 88x nm; for additional designs or specifications please visit our website: www.jenoptik.com

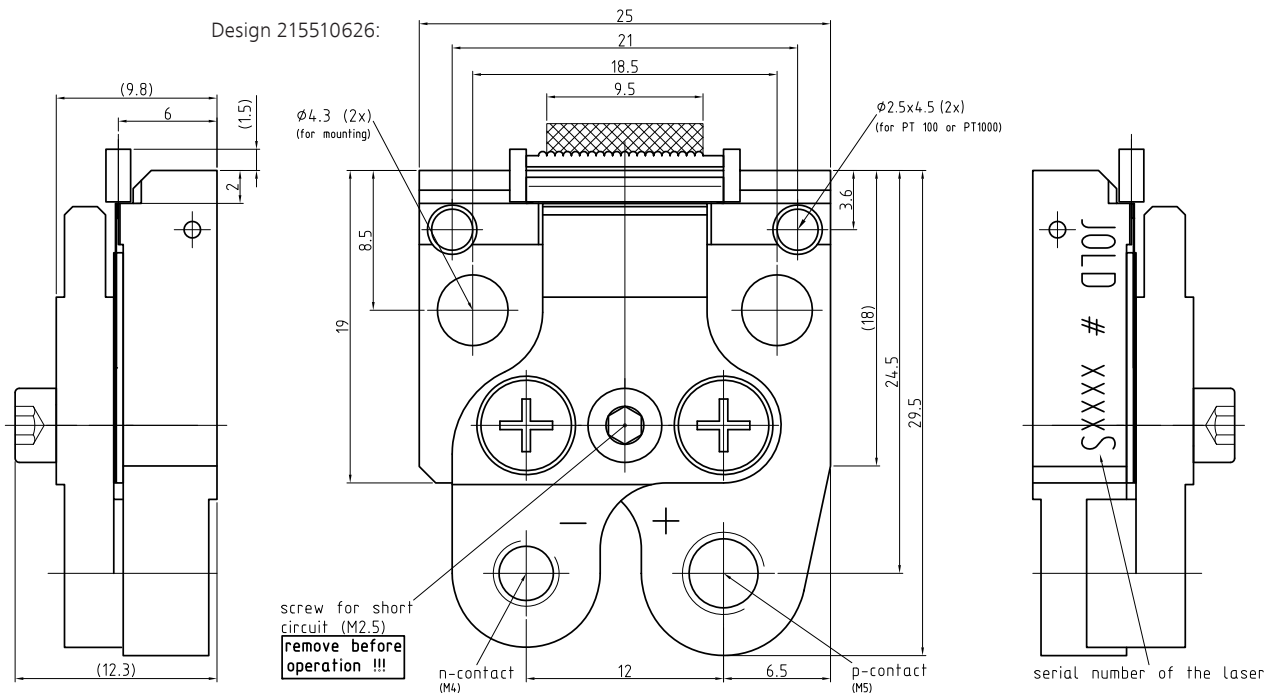

JENOPTIK | Lasers & Material Processing

JENOPTIK Laser GmbH

Goeschwitzer Strasse 29 | 07745 Jena | Germany

Phone: +49 3641 65-3053 | Fax: +49 3641 65-4011

E-mail: sales-laser.lm@jenoptik.com | www.jenoptik.com/diodelasers