



Horizontal Diode Laser Stacks

cw, passively cooled with tap water, wave guide



JOLD-310-HS-4L

Design 215850424

Features:

- High optical output power of 310 W cw
- High efficiency, low divergences
- Long lifetime > 2 years, high reliability

Applications:

- Pumping of solid-state lasers
- Material processing

Patent No. US 6 975 034

Horizontal Diode Laser Stacks

cw, passively cooled with tap water, wave guide

Specifications (Start of Life)

Product

JOLD-310-HS-4L, Design 215850424

Operation Mode	cw, power modulation only between threshold and maximum current		
Maximum Optical Output Power after Wave Guide	310	310	W
Center Wavelength at 25 °C	807	938	nm
Center Wavelength Variation at 25 °C	3	5	nm
Typical Spectral Bandwidth (FWHM)	5	5	nm
Maximum Spectral Bandwidth (FWHM)	6	6	nm
Typical Operation Current	92	92	A
Maximum Operation Current	102	102	A
Typical Threshold Current	20	15	A
Maximum Threshold Current	24	19	A
Typical Slope	4.4	4.1	W/A
Minimum Slope	3.7	3.5	W/A
Maximum Operating Voltage	8	8	V
Anode, Cathode Connectors	Thru holes		
Notes	Heat exchanger is potential free, watch current connectors for shortening		
Wave Guide	Thickness: 1 mm, length: 10.5 mm		
Operation Conditions	Cleanroom class 100, non-condensing atmosphere		
Expected Lifetime	> 2 years, under qualification		

Cooling:

Flow Rate	2 l/min		
Flow Rate Tolerance	± 10 %		
Typical Pressure Drop	60 kPa		
Maximum Inlet Pressure	500 kPa		
Water Temperature at Inlet	15 ... 35 °C		
Water Quality	Industrial grade, anti-freeze possible, particle filter < 100 µm (not included)		
Coolant Inlet/Outlet Diameter	App. 6 mm, to be sealed via o-rings (6.4 mm x 1.3 mm)		
Cooling System	Any materials that in combination with copper would form galvanic elements (e.g. Al, Zn, Brass) are not allowed.		
Note	Drawing of connecting base plate on request		

See Safety and General User Information!

Options on request: 976 nm; designs with different number of submounts; other wave guide sizes and geometries; fast axis collimation instead of wave guide (290 W cw after collimation, < 1° fast axis divergence)

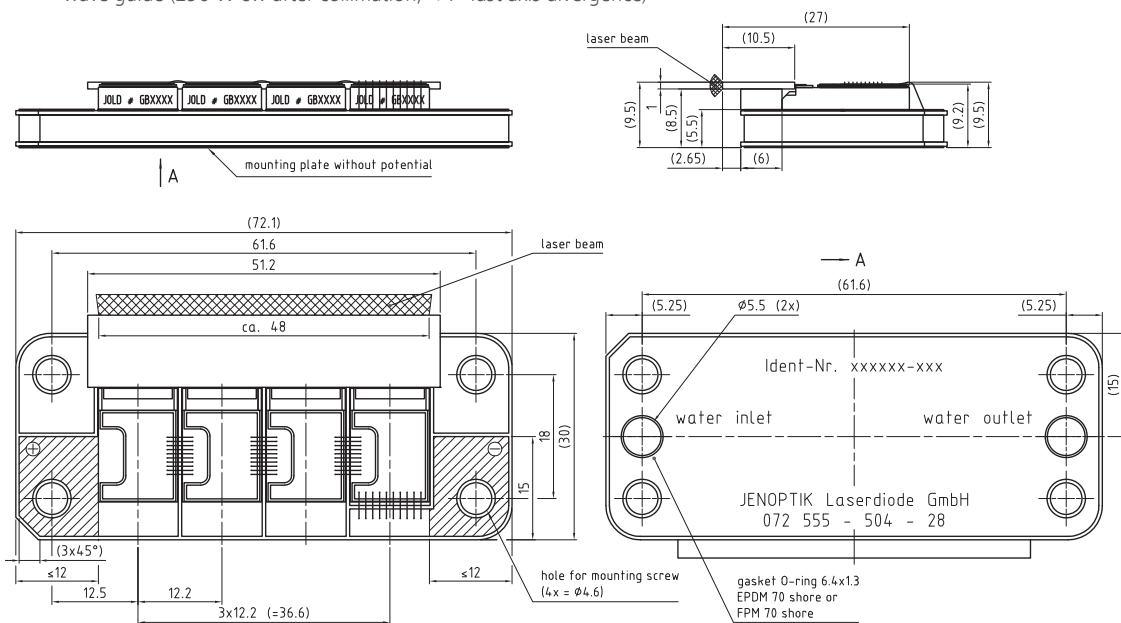

electrical interfaces

ATTENTION!!!
Watch for short circuits between (+ -) and mounting plate!
Use insulating inserts type 046, M4-5/32", D 10/ H 3,0 mm or comparable.

Patent No. US 6 975 034



JENOPTIK | Lasers & Material Processing

JENOPTIK Laser GmbH

Goeschwitzer Strasse 29 | 07745 Jena | Germany

Phone: +49 3641 65-3053 | Fax: +49 3641 65-4011

E-mail: sales-laser.lm@jenoptik.com | www.jenoptik.com/diodelasers