



## Open Heat Sink Diode Lasers

qcw, passively cooled, with and without collimation



JOLD-x-QPNN-1L  
JOLD-x-QPFN-1L

Design 215510124  
Design 215510126

### Features:

- High optical output power up to 300 W qcw without collimation and up to 270 W qcw after collimation
- High efficiency, low divergences
- Lifetime > 1 GShot, high reliability

### Applications:

- Pumping of solid-state lasers
- Illumination

# Open Heat Sink Diode Lasers

qcw, passively cooled, with and without collimation

## Preliminary Specifications (Start of Life)

Product	JOLD-x-QPNN-1L, Design 215510124		JOLD-x-QPFN-1L, Design 215510126		
Operation Mode	qcw	qcw	qcw	qcw	
Maximum Pulse Length / Duty Cycle	≤ 0.3 ms / ≤ 4 %	≤ 0.3 ms / ≤ 10 %	≤ 0.3 ms / ≤ 4 %	≤ 0.3 ms / ≤ 10 %	
Max. Optical Output Power	300	250			W
Max. Optical Output Power after Collimation			270	225	W
Center Wavelength at 25 °C	808	808	808	808	nm
Center Wavelength Variation at 25 °C	5	5	5	5	nm
Typical Spectral Bandwidth (FWHM)	3	3	3	3	nm
Maximum Spectral Bandwidth (FWHM)	5	5	5	5	nm
Typical Operation Current	275	230	275	230	A
Maximum Operation Current	290	255	290	255	A
Typical Threshold Current	17	17	17	17	A
Maximum Threshold Current	22	22	22	22	A
Typical Slope	1.20	1.20	1.05	1.10	W/A
Minimum Slope	1.05	1.05	0.95	0.90	W/A
Maximum Operating Voltage	2.2	2.2	2.2	2.2	V
Fast Axis Divergence (Full Power)			< 0.5	< 0.5	°
Typical Fast Axis Divergence FWHM	35	35			°
Typical Fast Axis Divergence 86 %	50	50			°
Typical Fast Axis Divergence 95 %	66	66			°
Typical Slow Axis Divergence FWHM	8	7	8	7	°
Typical Slow Axis Divergence 86 %	8	7	8	7	°
Typical Slow Axis Divergence 95 %	10	9	10	9	°
Anode, Cathode Connectors	Holes for screws M5, M4				
Operation Conditions	Cleanroom class 100, non-condensing atmosphere				
Expected Lifetime	> 1 GShot				

### Cooling:

Mounting	Via thermally conductive foil (thickness 25 ... 100 µm) on cooled surface (water cooled plate or TEC)
Note	<b>Do not mount via any paste-like media!</b>
Operation Temperature	15 ... 30 °C, measured with temperature sensor in heatsink

**See General User Information!**

Options on request: For additional designs or specifications please visit our website: [www.jenoptik.com](http://www.jenoptik.com)

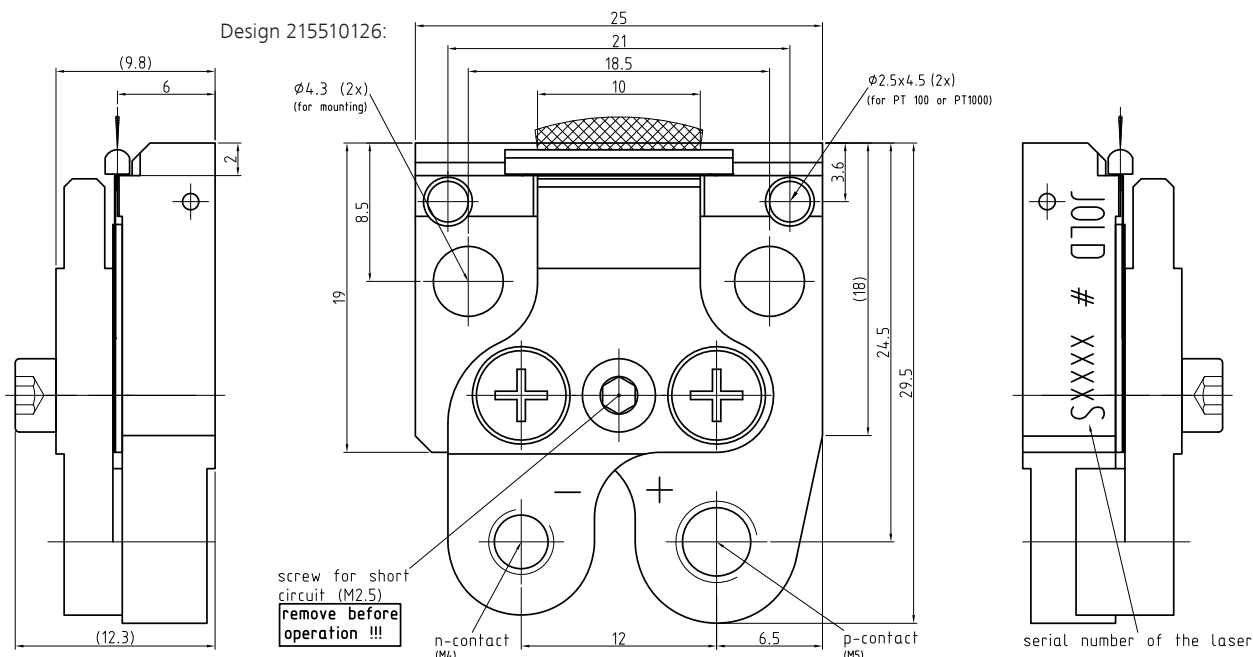

JENOPTIK | Lasers & Material Processing

JENOPTIK Laser GmbH

Goeschwitzer Strasse 29 | 07745 Jena | Germany

Phone: +49 3641 65-3053 | Fax: +49 3641 65-4011

E-mail: [sales-laser.lm@jenoptik.com](mailto:sales-laser.lm@jenoptik.com) | [www.jenoptik.com/diodelasers](http://www.jenoptik.com/diodelasers)