



Vertical Diode Laser Stacks

qcw, passively cooled



JOLD-x-Q-8A
JOLD-x-QF-8A

Design 220430824
Design 220430826

Features:

- High optical output power up to 300 W qcw per bar without collimation and 270 W qcw per bar after collimation
- High efficiency, low divergences
- Lifetime up to > 1 GShot, high reliability

Applications:

- Pumping of solid-state lasers
- Illumination
- Medical applications

Vertical Diode Laser Stacks

qcw, passively cooled

Specifications (Start of Life)

Product	JOLD-x-Q-8A, Design 220430824				JOLD-x-QF-8A, Design 220430826				
Operation Mode	qcw				qcw				
Maximum Pulse Length	≤ 0.2	≤ 0.2	≤ 1.5	≤ 3.0	≤ 0.2	≤ 0.2	≤ 1.5	≤ 3.0	ms
Maximum Duty Cycle	≤ 1	≤ 10	≤ 1	≤ 4	≤ 1	≤ 10	≤ 1	≤ 4	%
Maximum Pulse Power	2400	1200	2400	2000					W
Maximum Optical Power after Collimation					2160	1080	2160	1800	W
Number of Submounts	8	8	8	8	8	8	8	8	
Pulse Power per Submount	300	150	300	250	270	135	270	225	W
Center Wavelength at 25 °C	808	808	940	940	808	808	940	940	nm
Center Wavelength Variation at 25 °C	3	3	3	3	3	3	3	3	nm
Typical Spectral Bandwidth (FWHM)	3	3	5	5	3	3	5	5	nm
Maximum Spectral Bandwidth (FWHM)	6	6	7	7	6	6	7	7	nm
Typical Operation Current	285	165	300	260	285	165	300	260	A
Maximum Operation Current	300	180	315	275	300	180	315	275	A
Typical Threshold Current	23	23	16	16	23	23	16	16	A
Maximum Threshold Current	25	25	18	18	25	25	18	18	A
Typical Slope	9.2	8.5	8.5	8.2	8.3	7.7	7.7	7.4	W/A
Minimum Slope	8.6	7.6	8	7.7	7.7	6.8	7.2	6.9	W/A
Typical Operating Voltage	15.8	14.4	14.9	14.7	15.8	14.3	14.9	14.7	V
Maximum Operating Voltage	16.8	15.4	15.9	15.7	16.8	15.8	15.9	15.7	V
Fast Axis Divergence (Full Power)					< 0.5	< 0.5	< 0.5	< 0.5	°
Typical Fast Axis Divergence 95 %	66	66	47	47					°
Typical Slow Axis Divergence 95 %	10.0	8.5	10.0	8.5					°
Typical Polarization	90, TE	90, TE	90, TE	90, TE	90, TE	90, TE	90, TE	90, TE	%
Emitting Window	11.9 x 10	11.9 x 10	11.9 x 10	11.9 x 10	13 x 10	13 x 10	13 x 10	13 x 10	mm ²
Stack Pitch	1.7	1.7	1.7	1.7	1.7	1.7	1.7	1.7	mm
Anode, Cathode Connectors	Via two M3 screws each (base isolated)								
Operation Conditions	Cleanroom class 100, non-condensing atmosphere								
Expected Lifetime	> 1 GShot								

Cooling:

Mounting On cooled surface (water cooled plate or TEC)

Note **Do not mount via any paste-like media!**

Operation Temperature 15 ... 30 °C

Storage Temperature - 20 ... + 50 °C, non-condensing

See General User Information!

Options on request: variation of number of bars

Design 220430826:

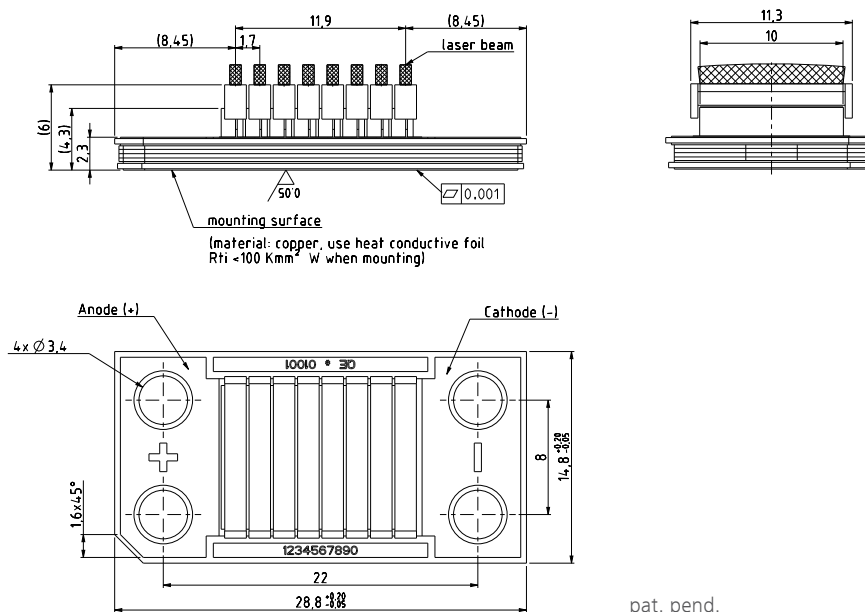

Specifications may change in compliance with our quality management system.

05/2011



JENOPTIK | Lasers & Material Processing

JENOPTIK Laser GmbH

Goeschwitzer Strasse 29 | 07745 Jena | Germany

Phone: +49 3641 65-3053 | Fax: +49 3641 65-4011

E-mail: sales-laser.lm@jenoptik.com | www.jenoptik.com/diodelasers