

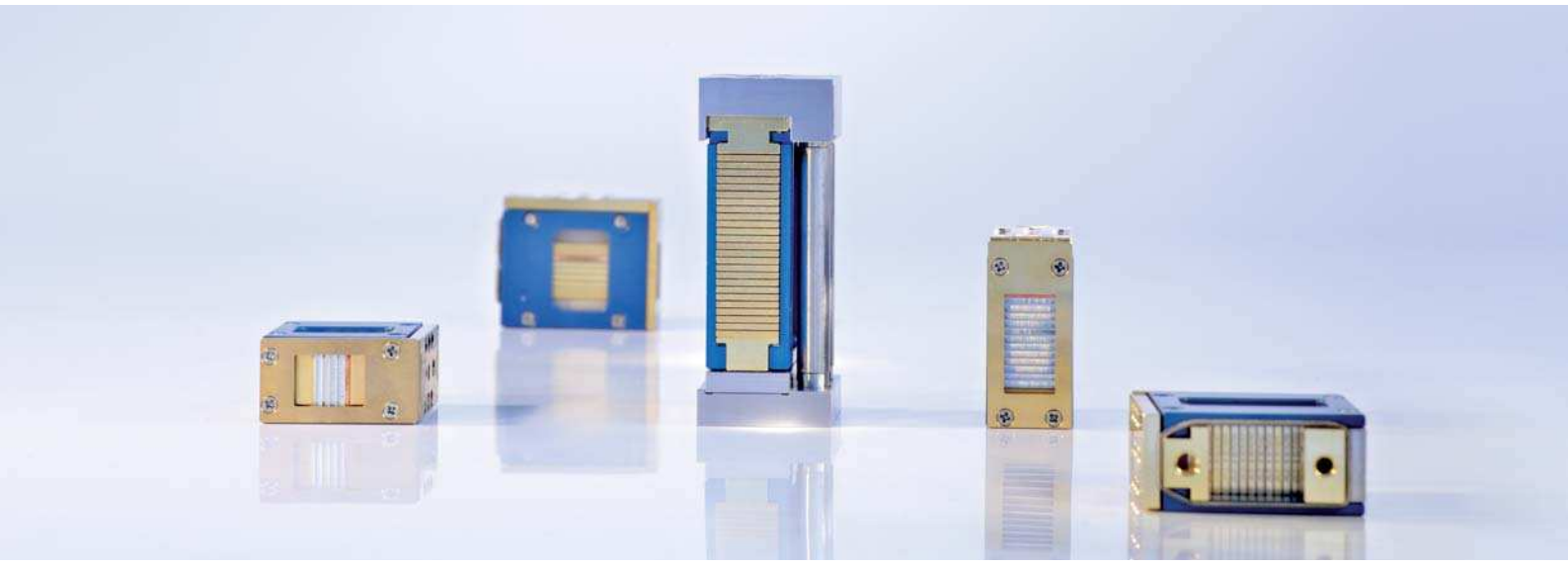

Vertical Diode Laser Stacks

qcw, actively cooled, with collimation



JOLD-x-QAFN-xA

Features:

- High optical output power up to 90 W qcw per bar after collimation
- High efficiency, low divergences
- Lifetime > 1 GShot, high reliability

Design 2104xxx26

210480326 (3 submounts)
210480426 (4 submounts)
210480526 (5 submounts)
210480626 (6 submounts)

210480826 (8 submounts)
210481026 (10 submounts)
210481226 (12 submounts)
210430626 (25 submounts)

Applications:

- Pumping of solid-state lasers and fiber lasers
- Material processing
- Medical applications (e.g. hair removal)

Vertical Diode Laser Stacks

qcw, actively cooled, with collimation

Specifications (Start of Life)

Product JOLD-x-QAFN-xA, Designs 210480326 (3 submounts), 210480426 (4 submounts), 210480526 (5 submounts), 210480626 (6 submounts), 210480826 (8 submounts), 210481026 (10 submounts), 210481226 (12 submounts), 210430626 (25 submounts)

Operation Mode	qcw																
Maximum Pulse Length / Duty Cycle	≤ 0.3 ms / ≤ 20 %																
Maximum Optical Output Power	270	360	450	540	720	900	1080	2250	270	360	450	540	720	900	1080	2250	W
Number of Submounts	3	4	5	6	8	10	12	25	3	4	5	6	8	10	12	25	
Power per Submount after Collimation	90	90	90	90	90	90	90	90	90	90	90	90	90	90	90	90	W
Center Wavelength at 25 °C	808																
Center Wavelength Variation at 25 °C	5	5	5	5	5	5	5	5	5	5	5	5	5	5	5	5	nm
Typical Spectral Bandwidth (FWHM)	3	3	3	3	3	3	3	3	3	3	3	3	3	3	3	3	nm
Maximum Spectral Bandwidth (FWHM)	5	5	5	5	5	5	5	5	5	5	5	5	5	5	5	5	nm
Typical Operation Current	105	105	105	105	105	105	105	105	110	110	110	110	110	110	110	110	A
Maximum Operation Current	120	120	120	120	120	120	120	120	125	125	125	125	125	125	125	125	A
Typical Threshold Current	14	14	14	14	14	14	14	14	12	12	12	12	12	12	12	12	A
Maximum Threshold Current	18	18	18	18	18	18	18	18	14	14	14	14	14	14	14	14	A
Typical Slope	3.0	4.0	5.0	6.0	8.0	9.9	11.9	24.8	2.8	3.7	4.6	5.6	7.4	9.2	11.1	23.0	W/A
Minimum Slope	2.5	3.3	4.2	5.0	6.7	8.4	10.1	21.2	2.3	3.1	3.9	4.7	6.3	7.9	9.5	19.9	W/A
Maximum Operating Voltage	6	8	10	12	16	20	24	50	7	9	11	14	18	22	27	55	V
Fast Axis Divergence (Full Power)	< 0.5																
Typical Slow Axis Divergence FWHM	6	6	6	6	6	6	6	6	7	7	7	7	7	7	7	7	°
Typical Slow Axis Divergence 86 %	7	7	7	7	7	7	7	7	8	8	8	8	8	8	8	8	°
Typical Slow Axis Divergence 95 %	8	8	8	8	8	8	8	8	9	9	9	9	9	9	9	9	°
Operation Conditions	Cleanroom class 100, non-condensing atmosphere																
Expected Lifetime	> 1 GShot																
Cooling:																	
Number of Submounts	3	4	5	6	8	10	12	25									
Flow Rate	1.3	1.7	2.0	2.3	3.0	3.6	4.3	8.3	l/min								
Flow Rate Tolerance	± 10 %																
Water Temperature	15 ... 35 °C																
Maximum Inlet Pressure	400 kPa																
Pressure Drop	< 200 kPa																
Water Quality	Deionized 2 ... 6 µS/cm, mixed bed ion exchanger, particle filter < 25 µm (not included)																
See Safety and General User Information!																	

Options on request: 915 nm; for additional designs or specifications please visit our website: www.jenoptik.com

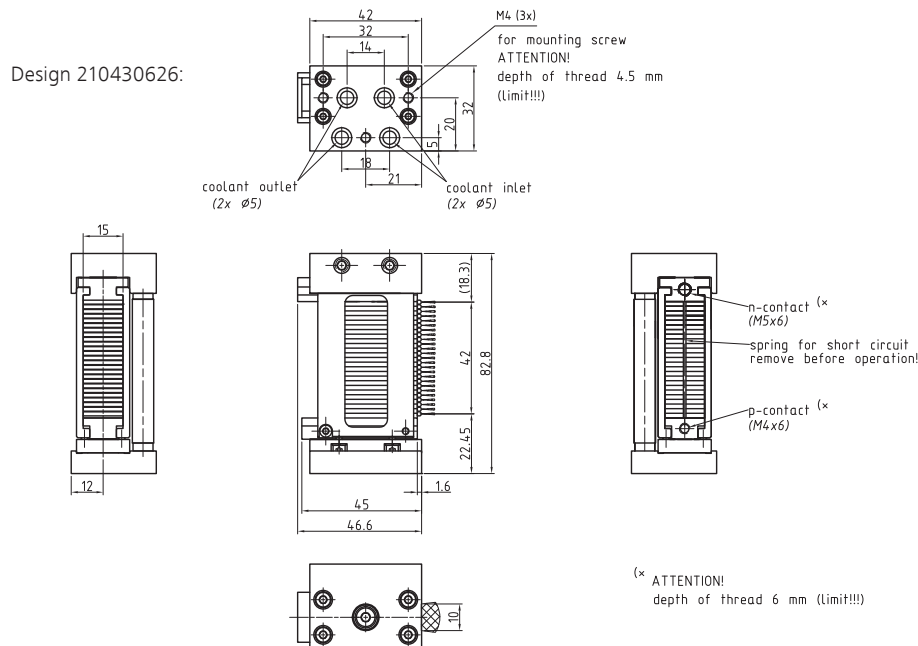

JENOPTIK | Lasers & Material Processing

JENOPTIK Laser GmbH

Goeschwitzer Strasse 29 | 07745 Jena | Germany

Phone: +49 3641 65-3053 | Fax: +49 3641 65-4011

E-mail: sales-laser.lm@jenoptik.com | www.jenoptik.com/diodelasers