



### Features

- Quad/dual core 3rd Generation Intel® Core™ Processor
- Mobile Intel® QM77 Express Chipset
- Up to 16GB ECC 1600MHz DDR3 memory in two SODIMM sockets
- Three Digital Display Interfaces (DDI) for DisplayPort /HDMI/DVI/SDVO
- Seven PCIe x1 (Gen 2), one PCIe x16 (Gen 3) for graphics (or general purpose x8/4/1)
- 2x SATA 6 Gb/s, 2x SATA 3 Gb/s, Gigabit Ethernet, USB 2.0, 4 USB 3.0
- COM Express® COM.0 R2.1 Type 6 Pinout
- Extended Temperature: -40°C to +85°C
- 50% Thicker PCB for high vibration environments

### Specifications

#### Core System

CPU	3rd Generation Intel® Core™ i7/i3, 22nm process, BGA type Intel® Core™ i7-3615QE 2.3GHz (up to 3.3GHz Turbo), 6MB L3 cache, 45W, quad core Intel® Core™ i7-3612QE 2.1GHz (up to 3.1GHz Turbo), 6MB L3 cache, 35W, quad core Intel® Core™ i7-3555LE 2.5GHz (up to 3.2GHz Turbo), 4MB L3 cache, 25W, dual core Intel® Core™ i7-3517UE 1.7GHz (up to 2.8GHz Turbo), 4MB L3 cache, 17W, dual core Intel® Core™ i3-3217UE 1.6GHz, 3MB L3 cache, 17W, dual core
Memory	Dual channel ECC 1600 MHz DDR3 memory up to 16 GB in dual SODIMM sockets
BIOS	AMI EFI with CMOS backup in 16 Mb SPI flash
Hardware Monitor	Supply voltages and CPU temperature
Debug Interface	XDP SFF-26 extension for ICE debug
Watchdog Timer	Programmable timer range to generate RESET
Expansion Busses	PCI Express x16 (Gen3) bus for discrete graphics solution or general purpose PCI Express (2 x8 or 1 x8 with 2 x4) 7 PCI Express x1: Lanes 0/1/2/3/4/5/6 LPC bus, SMBus (system), I <sup>2</sup> C (user)
Technologies	PAVP 3.0, Intel® AMT 8.0, Intel® VT, Intel® AES-NI, Intel® HT, Intel® HD Graphics with Dynamic Frequency, Intel® Turbo Boost, Dynamic Turbo, Intel® AVX 1.0, Intel® Quick Sync Video

#### Video

Integrated in Processor	Intel® HD Graphics 4000 at 650-1300 MHz
Integrated Video	DirectX 11.0, OpenGL 3.1, and OCL 1.1
Media Processing	Decode (HW JPEG & MJPEG decode), encode (full HW MPEG2 encode), transcode Intel® Clear Video HD Technology + enhanced media processing
VGA Interface	Analog VGA support with 300 MHz DAC Analog monitor support up to QXGA (2048 x 1536) and VGA hot plug
LVDS Interface	Dual channel 18/24-bit LVDS
Digital Display Interface	Three DDI ports supporting HDMI / DVI / DisplayPort or SDVO

#### Audio

Chipset	Integrated on Mobile Intel® QM77 Express chipset
Audio Codec	Implemented on carrier board

#### Ethernet

Chipset	Intel® Gigabit LAN PHY WG82579LM
Speed	10/100/1000 Mbps Ethernet

#### Multi I/O

Chipset	Integrated on Mobile Intel® QM77 Express chipset
USB	Supports up to eight ports USB 2.0, 4 USB 3.0
SATA	Two SATA 6 Gb/s, two SATA 3 Gb/s with support for RAID 0,1,5,10

#### Super I/O

Connected to LPC bus on carrier if needed (BIOS supports W83627DHG)

#### TPM (optional)

Chipset	Atmel AT97SC3204-U1A190
Type	TPM 1.2

#### Power

Input Power	AT mode (12 V +/- 5%) and ATX mode (12 V and 5 Vsb +/- 5%)
Power States	Supports S0, S1, S3, S4, S5
Power Consumption	12W typical (i7-36xxQE) 8W typical (i7-3555LE/i7-3517UE/i3-3217UE) S3: 0.85W S5: 0.55W
Smart Battery Support	Yes (BIOS supports LTC4100 and LTC1760)

#### Mechanical and Environmental

Size	COM Express Basic, 125 mm x 95 mm
Board Thickness	0.093" (2.3mm)
Operating Temperature	Standard: -20°C to 70°C Extended: -40°C to 85°C
Storage Temperature	-55°C to 85°C
Humidity	90% at 60°C non-condensing
Shock	50G peak-to-peak, 11ms duration, MIL-STD-202G Method 213B
Vibration	Operating: 11.96 Grms, 50-20,000 Hz, each axis, MIL-STD-202G Method 214A
Compatibility	PICMG COM Express COM.0 R2.1 Type 6
Certifications	CE, FCC, HALT

#### Operating Systems

Standard Support	Windows 7 Linux
Extended Support (BSP)	Windows XPe/7, WEC 7 Linux, VxWorks 6.9, QNX 6.5 AIDI Library

## Functional Diagram

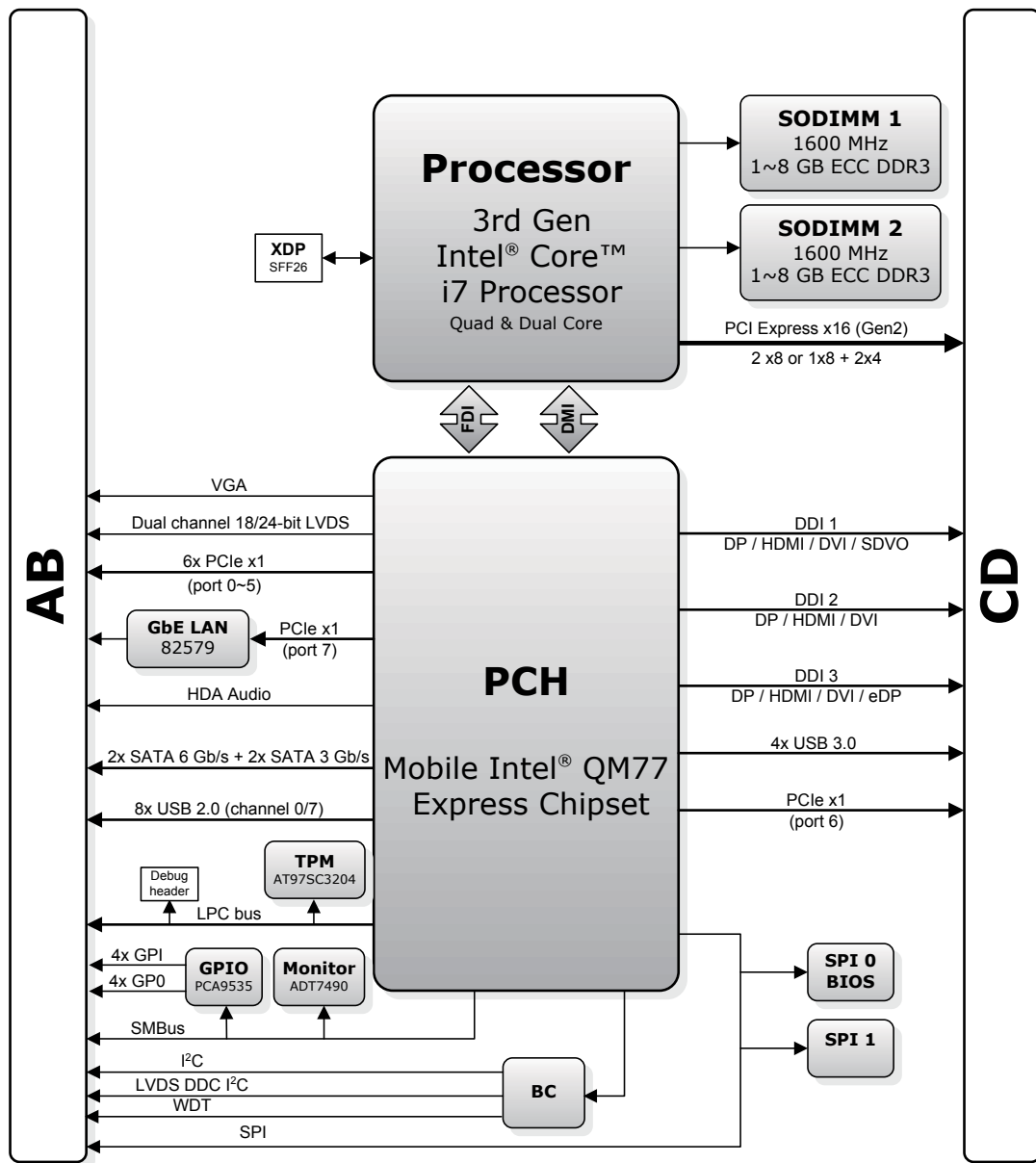

## Ordering Information

### Modules

Model Number	Description/Configuration
Express-IBR-i7-R-3615QE	Extreme Rugged COM Express Type 6 module with Intel® Core™ i7-3615QE 2.3GHz 45W Quad Core CPU, two DDR3 ECC SODIMMs supported
Express-IBR-i7-R-3612QE	Extreme Rugged COM Express Type 6 module with Intel® Core™ i7-3612QE 2.1GHz 35W Quad Core CPU, two DDR3 ECC SODIMMs supported
Express-IBR-i7-R-3555LE	Extreme Rugged COM Express Type 6 module with Intel® Core™ i7-3555LE 2.5GHz 25W Dual Core CPU, two DDR3 ECC SODIMMs supported
Express-IBR-i7-R-3517UE	Extreme Rugged COM Express Type 6 module with Intel® Core™ i7-3517UE 1.7GHz 17W Dual Core CPU, two DDR3 ECC SODIMMs supported
Express-IBR-i3-R-3217UE	Extreme Rugged COM Express Type 6 module with Intel® Core™ i3-3217UE 1.6GHz 17W Dual Core CPU, two DDR3 ECC SODIMMs supported

### Accessories

Model Number	Description/Configuration
<b>Heat Spreaders (for use with customer supplied thermal solution)</b>	
HTS-IBR-BTF	Heat spreader for Express-IBR with through-hole standoffs for top-mounting
HTS-IBR-B	Heat spreader for Express-IBR with threaded standoffs for bottom-mounting
<b>Passive Heatsinks (for use with 17 and 25W CPUs)</b>	
THSH-IBR-BTL	Heatsink for Express-IBR with through-hole standoffs for top-mounting
<b>Active Heatsinks (recommended for 35 and 45W CPUs)</b>	
THSH-IBR-CU	Heatsink with FAN for Express-IBR with through-hole standoffs for top-mounting