

NEW



Features

- Quad/dual core 3rd Generation Intel® Core™ i7/i5/i3 Processor
- Mobile Intel® QM77 Express Chipset
- Up to 16GB Dual Channel DDR3 SDRAM at 1600MHz
- Three Digital Display Interfaces (DDI) for DisplayPort /HDMI/DVI/SDVO
- Seven PCIe x1, one PCIe x16 (Gen3) for graphics (or general purpose x8/4/1)
- Two SATA 3 Gb/s, two SATA 6 Gb/s, Gigabit Ethernet, four USB 3.0, four USB 2.0

Specifications

Core System

CPU	3rd Generation Intel® Core™ i7/i5/i3, 22nm process, BGA type Intel® Core™ i7-3615QE 2.3GHz (3.1GHz Turbo), 6MB L3 cache, 45W (4C) Intel® Core™ i7-3612QE 2.1GHz (2.8GHz Turbo), 6MB L3 cache, 35W (4C) Intel® Core™ i7-3555LE 2.5GHz (3.1GHz Turbo), 4MB L3 cache, 25W (2C) Intel® Core™ i7-3517UE 1.7GHz (2.6GHz Turbo), 4MB L3 cache, 17W (2C) Intel® Core™ i5-3610ME 2.7GHz (3.1GHz Turbo), 3MB L3 cache, 35W (2C) Intel® Core™ i3-3120ME 2.4GHz, 3MB L3 cache, 35W (2C) Intel® Core™ i3-3217UE 1.6GHz, 3MB L3 cache, 17W (2C)
Memory	Dual channel 1333/1600 MHz DDR3 non-ECC memory up to 16GB in dual stacked SODIMM socket
Chipset	Intel® Mobile QM77 Express Chipset
L3 Cache	6MB (i7-3615QE and i7-3612QE), 4MB (i7-3555LE and i7-3517UE), 3MB (i5-3610ME, i3-3120ME and i3-3217UE)
BIOS	AMI EFI with CMOS backup in 16 Mbit SPI flash
Hardware Monitor	Supply voltages and CPU temperature
Debug Interface	XDP SFF-26 extension for ICE debug
Watchdog Timer	Programmable timer range to generate RESET
Expansion Busses	PCI Express x16 (Gen3) bus for discrete graphics solution or general purpose PCI Express (2 x8 or 1 x8 with 2 x4) 8 PCI Express x1: Lanes 0/1/2/3/4/5/6 are free, lane 7 is occupied by GbE LPC bus, SMBus (system), I ² C (user)

Video

Integrated in Processor	Intel® HD Graphics 4000 at 650–1200 MHz (depending on processor)
Integrated Video	DirectX 11, OpenGL 3.1, OpenCL 1.1
Feature Support	Intel Clear Video HD Technology Advanced Scheduler 2.0, 1.0, XPDM support DirectX Video Acceleration (DXVA) support for full AVC/VC1/MPEG2 hardware decode
VGA Interface	Analog VGA support with 300 MHz DAC Analog monitor support up to QXGA (2048 x 1536) and VGA hot plug
LVDS Interface	Dual channel 18/24-bit LVDS
Digital Display Interface	Three DDI ports supporting HDMI/DVI/DisplayPort or SDVO

Audio

Chipset	Integrated on Intel® QM77 PCH
Audio Codec	On Express-BASE6 carrier (ALC886)

Ethernet

Chipset	Intel® Gigabit Ethernet PHY WG82579LM
Interface	10/100/1000 Mbps Ethernet

Multi I/O and Storage

Chipset	Integrated on QM77 PCH
USB	4 ports USB 3.0 (USB0~3) and 4 ports USB 2.0 (USB4~7)
SATA	Supports two SATA ports at 6 Gb/s and two ports at 3 Gb/s with support for RAID 0,1,5,10

Super I/O

Connected to LPC bus on carrier if needed

TPM (optional)

Chipset	Infineon SLB9635TT1.2
Type	TPM 1.2

Power

Input Power	8.5~20V only (AT), 8.5~20V and 5Vsb (ATX)
Power States	Supports S0, S1, S3, S4, S5
Power Consumption	TBD
Smart Battery Support	Yes

Mechanical and Environmental

Operating Temperature	0°C to 60°C
Storage Temperature	-20°C to 80°C
Humidity	90% at 60°C
Shock	15G peak-to-peak, 11ms duration, non-operating
Vibration	Non-operating: 1.88Grms, 5-500Hz, each axis Operating: 0.5Grms, 5-500Hz, each axis
Compatibility	COM Express Type 6, Basic form factor 125mm x 95mm
Certification	CE, FCC, HALT

Operating Systems

Standard Support	Windows® 7 Linux®
Extended Support (BSP)	Embedded XP support package Linux® BSP VxWorks 6.x AIDI Library for Windows® and Linux®

Functional Diagram

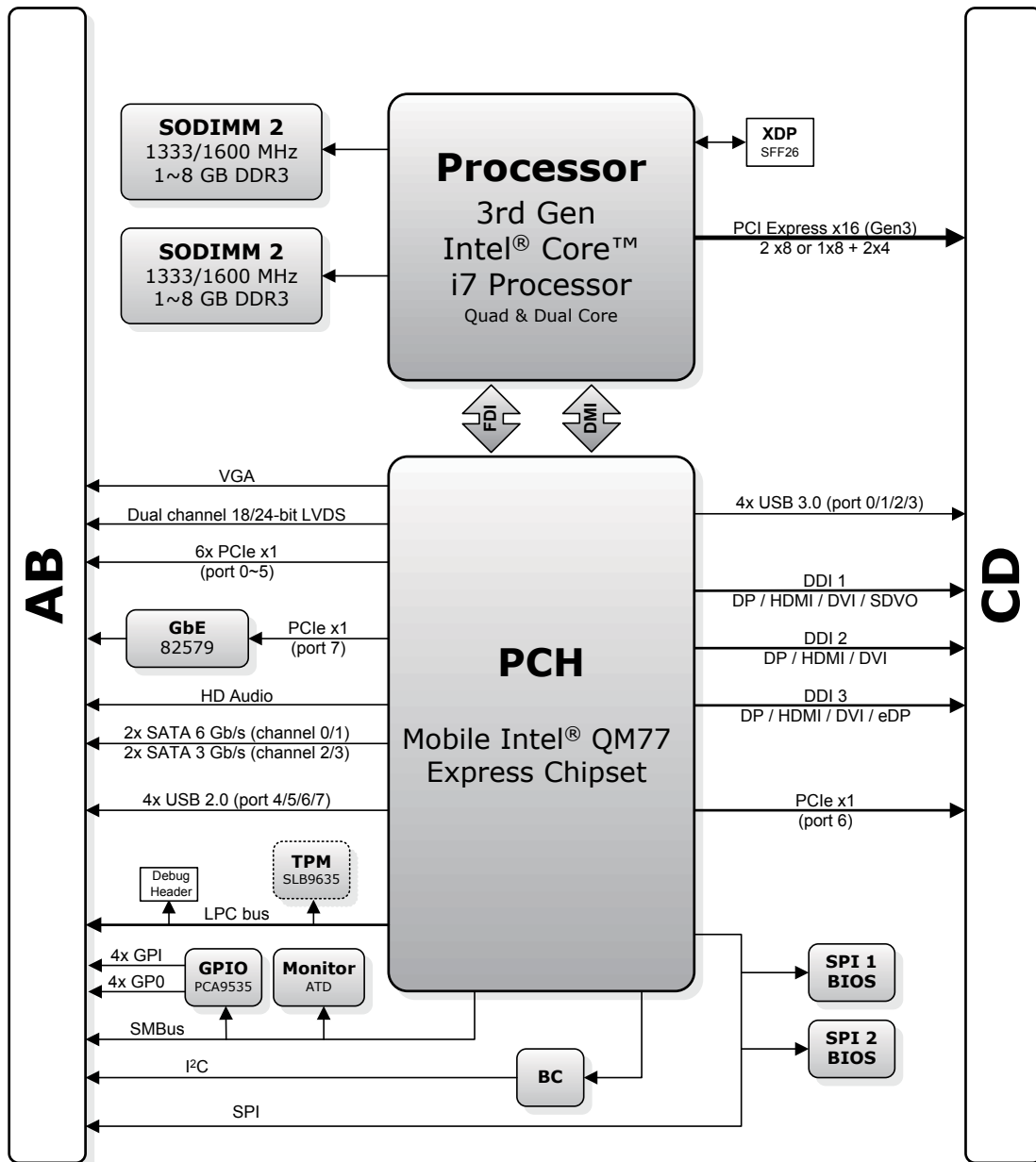

Ordering Information

Modules

Model Number	Description/Configuration
Express-IB-i7-3615QE	COM Express® Type 6 module with 4C Intel® Core™ i7-3615QE SV processor at 2.3 GHz with QM77 chipset
Express-IB-i7-3612QE	COM Express® Type 6 module with 4C Intel® Core™ i7-3612QE SV processor at 2.1 GHz with QM77 chipset
Express-IB-i7-3555LE	COM Express® Type 6 module with 2C Intel® Core™ i7-3555LE LV processor at 2.5 GHz with QM77 Chipset
Express-IB-i7-3517UE	COM Express® Type 6 module with 2C Intel® Core™ i7-3517UE ULV processor at 1.7 GHz with QM77 Chipset
Express-IB-i5-3610ME	COM Express® Type 6 module with 2C Intel® Core™ i5-3610ME SV processor at 2.7 GHz with QM77 Chipset
Express-IB-i3-3120ME	COM Express® Type 6 module with 2C Intel® Core™ i3-3120ME SV processor at 2.4 GHz with QM77 Chipset
Express-IB-i3-3217UE	COM Express® Type 6 module with 2C Intel® Core™ i3-3217UE ULV processor at 1.6 GHz with QM77 Chipset

Accessories

Model Number	Description/Configuration
Passive Heatsinks	
THSH-IB-B	High Profile Heatsink for Express-IB with threaded standoffs
Heat Spreaders	
HTS-IB-B	Heatspreader for Express-IB with threaded standoffs
Heatsink with Active Cooling	
THSF-IB-B	High Performance Heatsink with Fan for Express-IB 2C with threaded standoffs