

Express-IBE2

COM Express® Type 2 Module with 3rd Generation Intel® Core™ i7/i5/i3 Processor and QM77 Chipset



SEMA



Features

- Intel® Quad or Dual Core™ i7/i5/i3 Processor
- Intel® QM77 Chipset
- Up to 16GB Dual Channel DDR3 SDRAM at 1600MHz
- Single/dual channel 18/24-bit LVDS and SDVO
- Five PCIe x1, one PCIe x16 (Gen3) for graphics (or general purpose x8/4/1)
- 2x SATA 3 Gb/s, 2x SATA 6 Gb/s, GbE, 8x USB 2.0
- Supports Smart Embedded Management Agent (SEMA) functions

Specifications

Core System

CPU	3rd Generation Intel® Ivy Bridge 22nm process, BGA type Intel® Core™ i7-3615QE 2.3GHz, 6MB L3 cache, 45W (4C) Intel® Core™ i7-3612QE 2.1GHz, 6MB L3 cache, 35W (4C) Intel® Core™ i7-3555LE 2.5GHz, 4MB L3 cache, 25W (2C) Intel® Core™ i7-3517UE 1.7GHz, 4MB L3 cache, 17W (2C) Intel® Core™ i5-3610ME 2.7GHz, 3MB L3 cache, 35W (2C) Intel® Core™ i3-3120ME 2.4GHz, 3MB L3 cache, 35W (2C) Intel® Core™ i3-3217UE 1.6GHz, 3MB L3 cache, 17W (2C)
Memory	Dual channel 1333/1600 MHz DDR3 memory with ECC support up to 16GB in dual stacked SODIMM socket
Chipset	Intel® Mobile QM77 Express Chipset
L3 Cache	6MB (i7-3615QE and i7-3612QE), 4MB (i7-3555LE and i7-3517UE), 3MB (i5-3610ME, i3-3120ME and i3-3217UE)
BIOS	AMI EFI with CMOS backup in 16 Mbit SPI flash
Hardware Monitor	Supply voltages and CPU temperature
Debug Interface	XDP SFF-26 extension for ICE debug
Watchdog Timer	Programmable timer range to generate RESET
Expansion Busses	PCI Express x16 (Gen3) bus for discrete graphics solution or general purpose PCI Express (2 x8 or 1 x8 with 2 x4) 5 PCI Express x1: Lanes 0/1/2/3/4 are free, lane 5 is occupied by PATA, lane 6 is occupied by PCI bus and lane 7 is occupied by GbE LPC bus, SMBus (system), I ² C (user)

Video

Integrated in Processor	Intel® HD Graphics 4000 at 650–1200 MHz (depending on processor)
Integrated Video	DirectX 11, OpenGL 3.1, OpenCL 1.1
Feature Support	Intel Clear Video HD Technology Advanced Scheduler 2.0, 1.0, XPDM support DirectX Video Acceleration (DXVA) support for full AVC/VC1/MPEG2 hardware decode
VGA	Analog VGA support with 300 MHz DAC Analog monitor support up to QXGA (2048 x 1536) and VGA hot plug
LVDS	Single/dual channel 18/24-bit LVDS
SDVO	SDVO multiplexed with PCIe x16 lane 0-7

Audio

Chipset	Integrated on Intel® PCH QM77
Audio Codec	On Express-BASE carrier (ALC886)

SEMA BMC

Voltage and Current Monitoring, Flat Panel Control, I²C bus 100/200/400, Failsafe Dual BIOS, Module Logistics, Runtime information, User Flash Area, Power Control, and ECO mode support

Ethernet

Chipset	Intel® Gigabit Ethernet PHY WG82579LM
Interface	10/100/1000 Mbps Ethernet

Multi I/O and Storage

Chipset	Integrated on QM77
USB	8 ports USB 2.0 (USB0-7)
SATA	Supports two SATA ports at 6 Gb/s and two ports at 3 Gb/s with support for RAID 0,1,5,10
IDE (PATA)	SATA to PATA bridge on SATA channel 1, Master only

Super I/O

Connected to LPC bus on carrier if needed

TPM (optional)

Chipset	Atmel AT97SC3209
Type	TPM 1.2

Power

Input Power	AT mode (12 V +/- 5%) and ATX mode (12 V and 5 Vsb +/- 5%)
Power States	Supports S0, S1, S3, S4, S5
Power Consumption	TBD
Smart Battery Support	Yes

Mechanical and Environmental

Operating Temperature	0°C to 60°C
Storage Temperature	-20°C to 80°C
Humidity	90% at 60°C
Shock	15G peak-to-peak, 11ms duration, non-operating
Vibration	Non-operating: 1.88Grms, 5-500Hz, each axis Operating: 0.5Grms, 5-500Hz, each axis
Compatibility	COM Express Type 2, Basic form factor 125mm x 95mm
Certification	CE, FCC, HALT

Operating Systems

Standard Support	Windows 7 Linux
Extended Support (BSP)	Embedded XP support package Linux BSP VxWorks 6.x AIDI Library for Windows and Linux

Functional Diagram

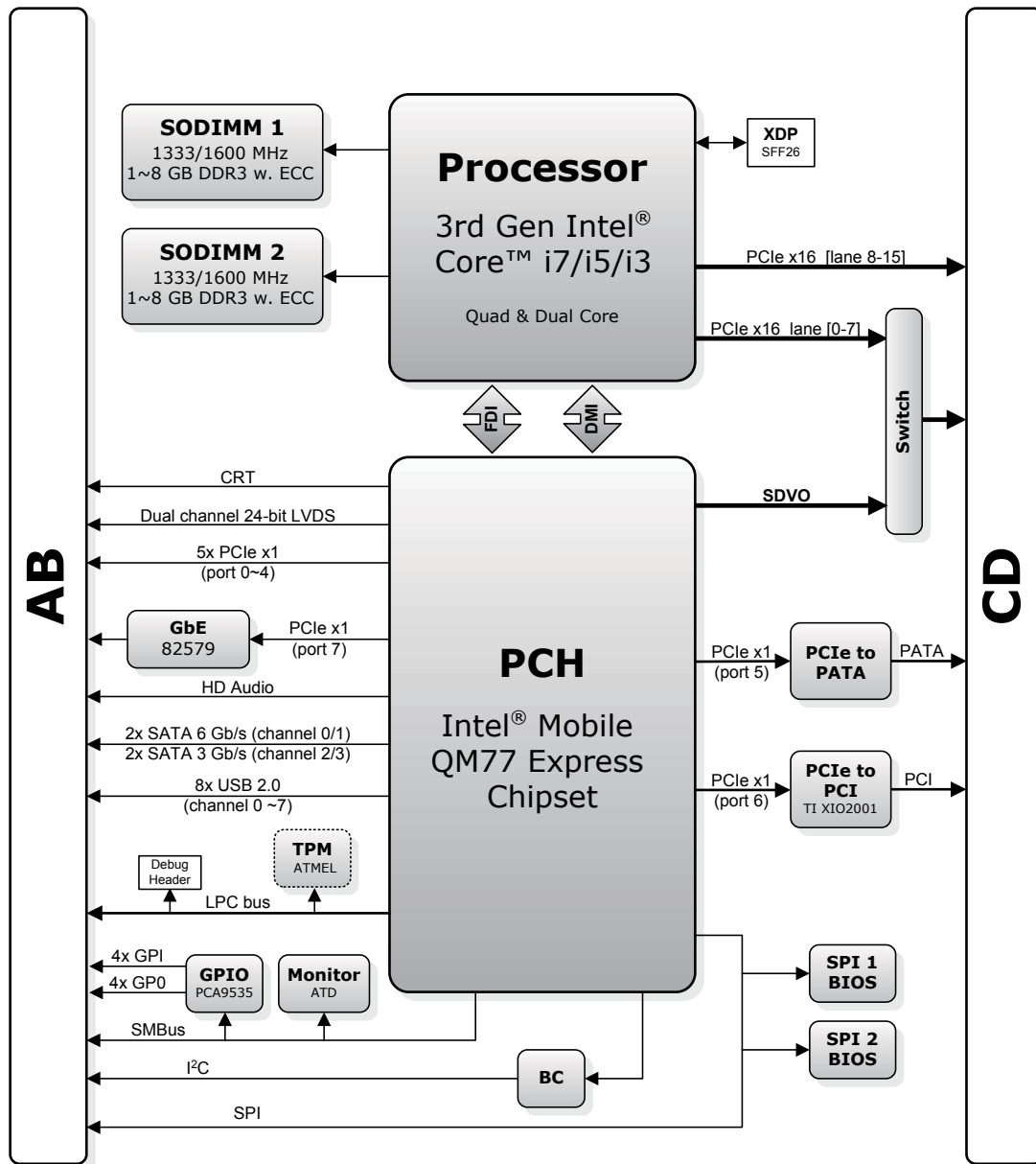

Ordering Information

Modules

Model Number	Description/Configuration
Express-IBE2-i7-3615QE	COM Express® Type 2 module with 4C Intel® Core i7-3615QE SV processor at 2.3 GHz with QM77 chipset
Express-IBE2-i7-3612QE	COM Express® Type 2 module with 4C Intel® Core i7-3612QE SV processor at 2.1 GHz with QM77 chipset
Express-IBE2-i7-3555LE	COM Express® Type 2 module with 2C Intel® Core i7-3555LE LV processor at 2.5 GHz with QM77 Chipset
Express-IBE2-i7-3517UE	COM Express® Type 2 module with 2C Intel® Core i7-3517UE ULV processor at 1.7 GHz with QM77 Chipset
Express-IBE2-i5-3610ME	COM Express® Type 2 module with 2C Intel® Core i5-3610ME SV processor at 2.7 GHz with QM77 Chipset
Express-IBE2-i3-3120ME	COM Express® Type 2 module with 2C Intel® Core i3-3120ME SV processor at 2.4 GHz with QM77 Chipset
Express-IBE2-i3-3217UE	COM Express® Type 2 module with 2C Intel® Core i3-3217UE ULV processor at 1.6 GHz with QM77 Chipset

Accessories

Model Number	Description/Configuration
Heat Spreaders	
HTS-IBE2-B	Heatspreader for Express-IBE2 for bottom mounting
HTS-IBE2-BT	Heatspreader for Express-IBE2 for top mounting
Passive Heatsinks	
THS-IBE2-B	Low Profile Heatsink for Express-IBE2 for bottom mounting
THSH-IBE2-B	High Profile Heatsink for Express-IBE2 for bottom mounting
Heatsink with Active Cooling	
THSF-IBE2-B	High Performance Heatsink with Fan for Express-IBE2 with max 35W CPU for top mounting