



## CAT5 KVM extender

Supports VGA video at resolutions up to 1600 x 1200

Extends keyboard, video, mouse, serial, and audio signals up to 1,000 feet away

PS/2, Sun, or USB support

PS/2 Single or Dual models

PS/2 Serial and full stereo audio options

Easily adapted to your system

## Features and Benefits

- Supports:
  - VGA video modes
  - PS/2, Sun or USB keyboards and mice
  - Serial and Full stereo audio (optional)
- Single and Dual models available. The Dual model allows for an additional local user
- Extend a KVM station up to 1,000 feet away from a CPU using CAT5 cable
- Video resolutions up to 1600 x 1200 @ 60Hz
- Video equalization and gain controls to adjust brightness and clarity
- Compatible with Rose Electronics KVM switches such as ServeView Pro, UltraView Pro, and UltraMatrix
- Operating system independent
- Uses a microprocessor to emulate the keyboard and mouse. The keyboard and mouse on the remote unit do not have to be connected for the PC to boot; only the local unit must be connected to the PC.
- Fully automatic KVM sharing (Dual access models)
- Rack mount kits available in 19", 23", and 24" sizes

## The CrystalView™ CAT5 Advantage . . .

The CrystalView CAT5 is the KVM extender of choice for businesses big and small that must control a computer from an extended distance.

The CrystalView CAT5 allows you to position a computer up to 1,000 feet away from the KVM station using common twisted pair CAT5 cable. Video equalization and gain controls on the remote unit adjust brightness and clarity to compensate for image quality loss over long cable lengths.

Access to your computers is made convenient in a variety of situations. You can locate users away from hazardous industrial environments; locate computers away from areas vulnerable to theft of hardware and data, reduce noise and heat, and increase desk and floor space.

The Serial/Audio model allows stereo audio to be transmitted in either direction across the CAT5 link simultaneously. Many serial devices like a Touchscreen can plug directly into the serial port on the Remote Unit

The CrystalView CAT5 extender is available in following models:

- PC single or dual access
- PC single or dual access with serial and audio
- SUN single or dual access
- USB dual access

The dual access versions provide for a second KVM station at the local unit, giving access to the computer from either the local or remote unit.

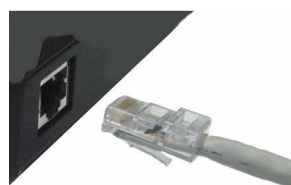

Uses standard CAT5 cable

## Typical Application

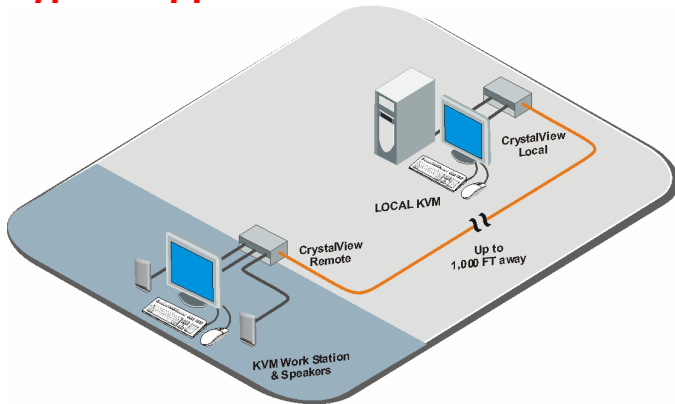

Accessing a computer from two locations, one is local, the other is 1,000 feet away

**CrystalView CAT5 basics** The CrystalView CAT5 consists of a local unit that connects to a PC, server, or KVM switch and a remote unit that connects to a keyboard, monitor, and mouse. The local and remote units are connected together with up to 1,000 feet of standard CAT5 cable. The ideal way to apply the CrystalView CAT5 is to connect the Local unit to a Rose Electronics KVM switch. Expanding the switch allows access to 1,000 computers or servers.

**Installation** Installing the CrystalView CAT5 is as easy as connecting the KVM station to the remote unit, a computer to the local unit, and connecting the local and remote units together with CAT5 cable.

**Models** The CrystalView CAT5 is available in PS/2, SUN, and USB models with serial and audio options.

**Keyboard and mouse emulation** The CrystalView CAT5 uses a microprocessor to emulate the keyboard and mouse. This means that the keyboard and mouse on the remote unit does not have to be connected for the PC to boot. Only the Local unit must be connected to the PC.

### Part Numbers

CRK-1P Single KVM Extender (Local and Remote)  
 CRK-2P Dual KVM Extender (Local and Remote)  
 CRK-1USB Single access – USB  
 CRK-2USB Dual access - USB  
 /AUD suffix = audio and serial option  
 /SUN suffix = SUN connectors

## Specifications

Dimensions	Width	Depth	Height	Weight
Single (in)	8.80	3.40	1.75	1.40 lbs
Single (cm)	22.3	8.64	4.45	0.61 kg
Dual (in)	8.80	3.40	1.75	1.60 lbs
Dual (cm)	22.3	8.64	4.45	0.72 kg
Video:				
Resolution	1600 x 1200 (200feet)			
	1280 x 1024 (300 feet)			
	1024 x 768 (300 – 1,000 feet)			
Compatibility	SVGA, VGA, XGA, RGB			
Levels	0.7V p-p			
Sync type	Separate/composite TTL level			
Support:	Keyboards – PC/AT, PS/2, SUN, USB			
	Video – VGA, SVGA, XGA, RGB			
	Mouse – PS/2, SUN, USB			
	Microsoft IntelliMouse			
	Logitech three button			
Connectors:				
Video in/out	HD15F			
CPU connect	HD15F, PS/2, PS/2 or USB type B			
Keyboard	PS/2 – MiniDin-6F			
	Sun – MiniDin-8F			
	USB – USB type A			
Mouse	PS/2 – MiniDin-6F			
	Sun – MiniDin-8F			
	USB – USB type A			
Serial	Local – DB9F			
	Remote – DB9M			
Audio	(2) 3.5mm stereo jack			
CAT5	RJ45F			
Interconnect	CAT5 UTP/STP, EIA/TIA 568			
Power:	Local – From PC			
	Remote – 9V 1,000 ma external			
Serial Data:				
Baud Rate	up to 19,200			
Data Flow	Format independent			
Flow control	RTS, CTS, DTR, DSR			
Audio Data:				
Signal level	5V p-p			
Impedance	47KΩ			
Connectors	3.5mm stereo jack			
Transmission	16 bit, 38.4KHz Digitized audio			
Microphone	Powered or un-powered			
Speakers	Powered			
Environmental:	Temp. 0°C – 45°C			
	Humidity 0% – 80% non-condensing			
Approvals	CE			



USB model



Sun model



PC model

Receiver (top)

Transmitter (bottom)

■ Phone: 281-933-7673 ■ E-mail: sales@rose.com ■

10707 Stancliff Rd. Houston, TX 77099

Rose Electronics – Europe: +49 (0)2454 969442 Rose Electronics – Asia: +65 6324 2322

DS-CRV 2.7

© Copyright 2004 Rose Electronics. All rights reserved



WWW.ROSE.COM