

SDQ14	SDQ14	4	SDQ30	SDQ30	4	SDQS2	SDQS2	4
SDQ9	SDQ9	4	SDQ25	SDQ25	4	SDQS2#	SDQS2#	4
SDQ11	SDQ11	4	SDQ27	SDQ27	4	SDQS3	SDQS3	4
SDQ12	SDQ12	4	SDQ28	SDQ28	4	SDQS3#	SDQS3#	4
						SDQM2	SDQM2	4
						SDQM3	SDQM3	4
SDQ15	SDQ15	4	SDQ31	SDQ31	4			
SDQ8	SDQ8	4	SDQ24	SDQ24	4	SDQS0	SDQS0	4
SDQ10	SDQ10	4	SDQ26	SDQ26	4	SDQS0#	SDQS0#	4
SDQ13	SDQ13	4	SDQ29	SDQ29	4	SDQS1	SDQS1	4
						SDQS1#	SDQS1#	4
SDQ7	SDQ7	4	SDQ23	SDQ23	4	SDQM0	SDQM0	4
SDQ0	SDQ0	4	SDQ16	SDQ16	4	SDQM1	SDQM1	4
SDQ2	SDQ2	4	SDQ18	SDQ18	4			
SDQ5	SDQ5	4	SDQ21	SDQ21	4			
SDQ6	SDQ6	4	SDQ22	SDQ22	4			
SDQ1	SDQ1	4	SDQ17	SDQ17	4			
SDQ3	SDQ3	4	SDQ19	SDQ19	4			
SDQ4	SDQ4	4	SDQ20	SDQ20	4			

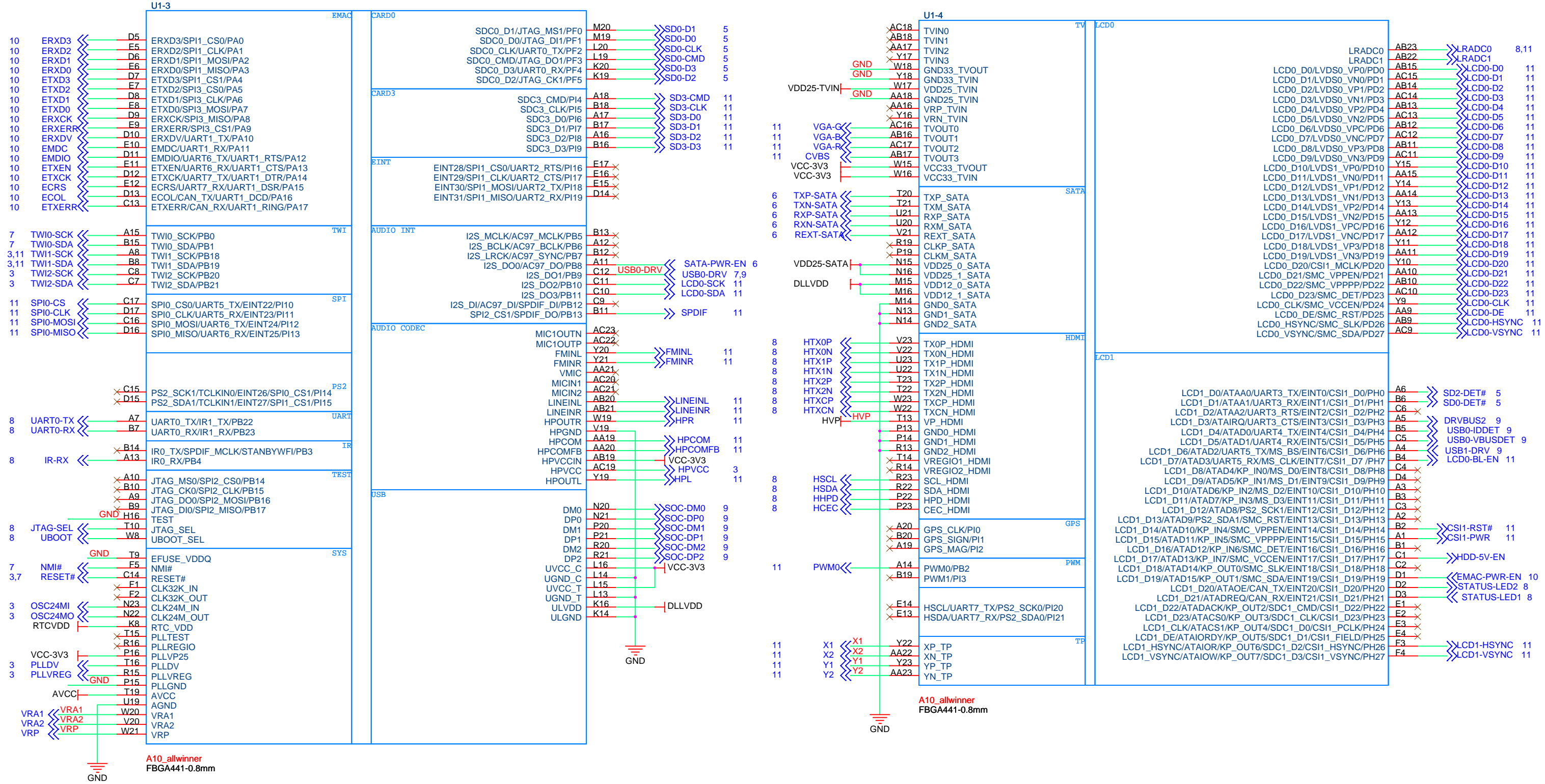

**DRAM-DLL**

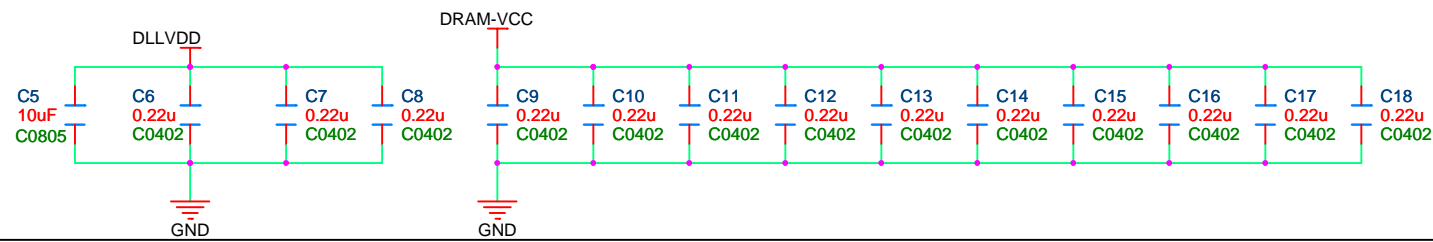

**PLL-NAND**

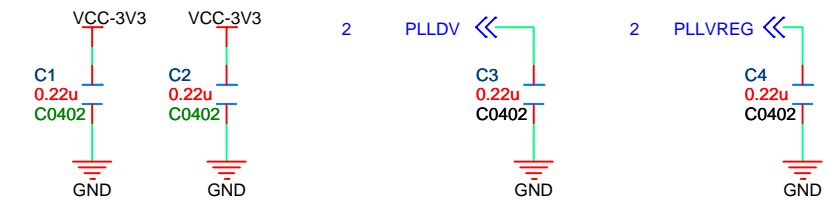

**CRYSTAL**

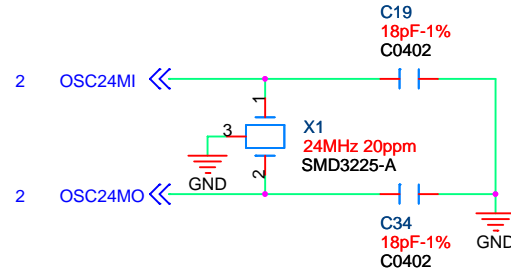

**CORE**

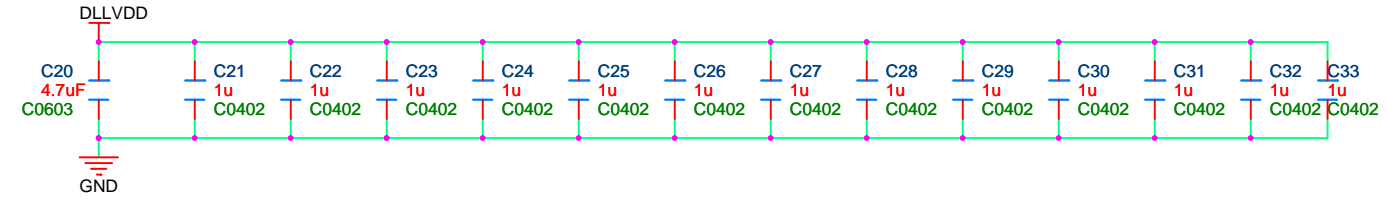

**AUDIO-LRADC**

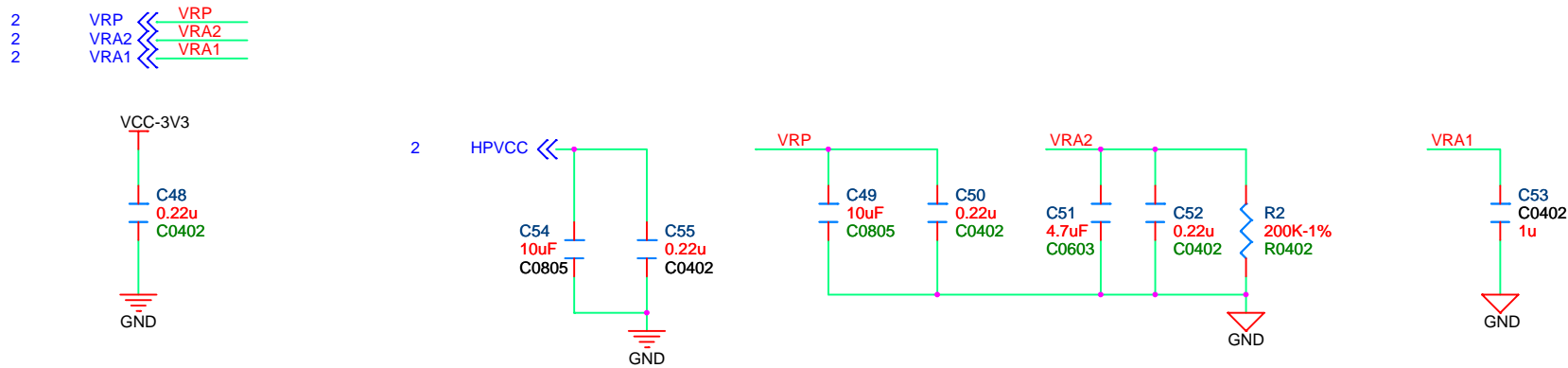

**PIO-INTFACE**

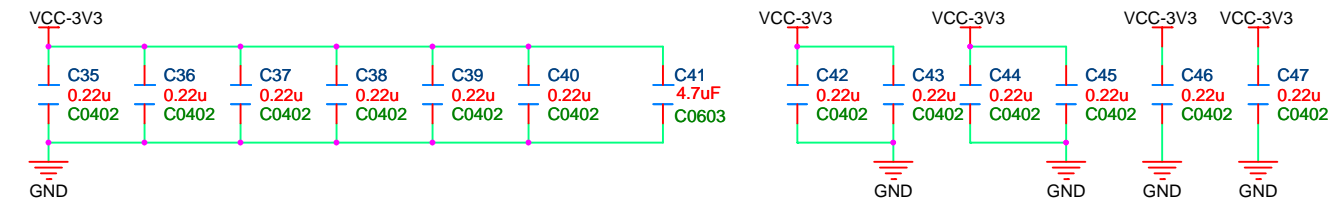

**CPU**

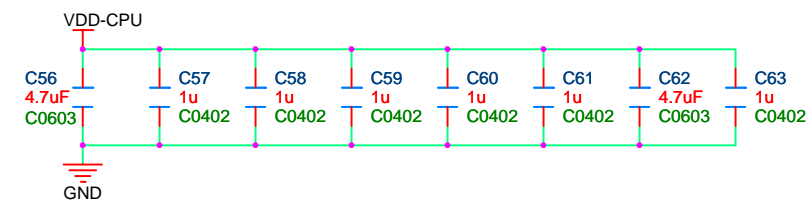

**USB-TV-CSI**

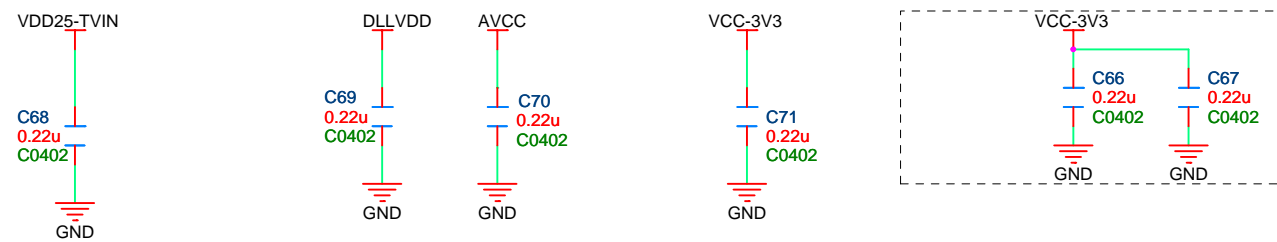

**RESET-RTC**

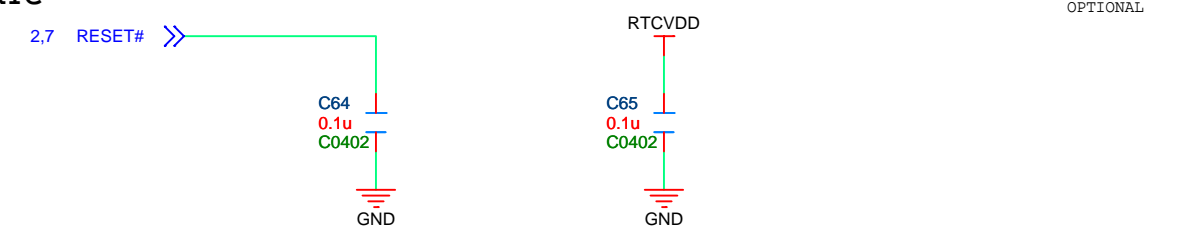

**HDMI**

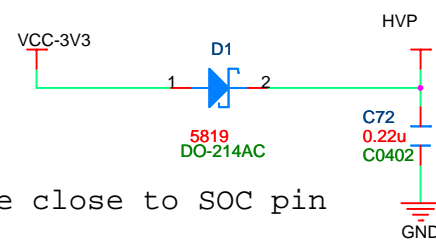

**OTHERS**

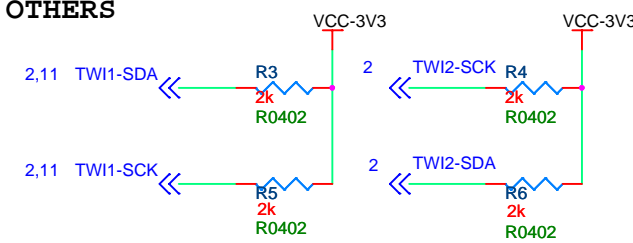

Title		
A10-cubieboard-2012-08-08		
Size	Document Number	Rev
A3	<Doc>	V1.0
Date:	Sheet	3 of 11

# DDR3

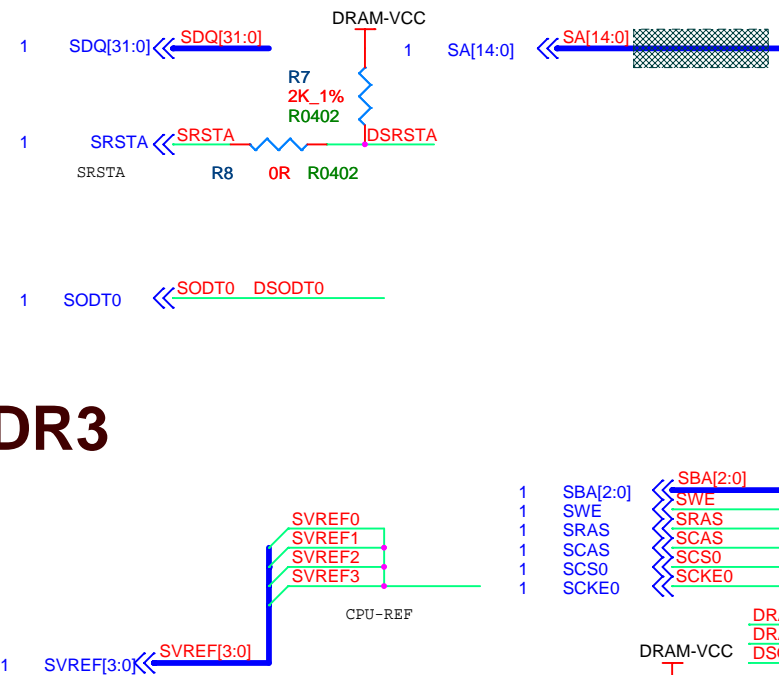

### CARD0

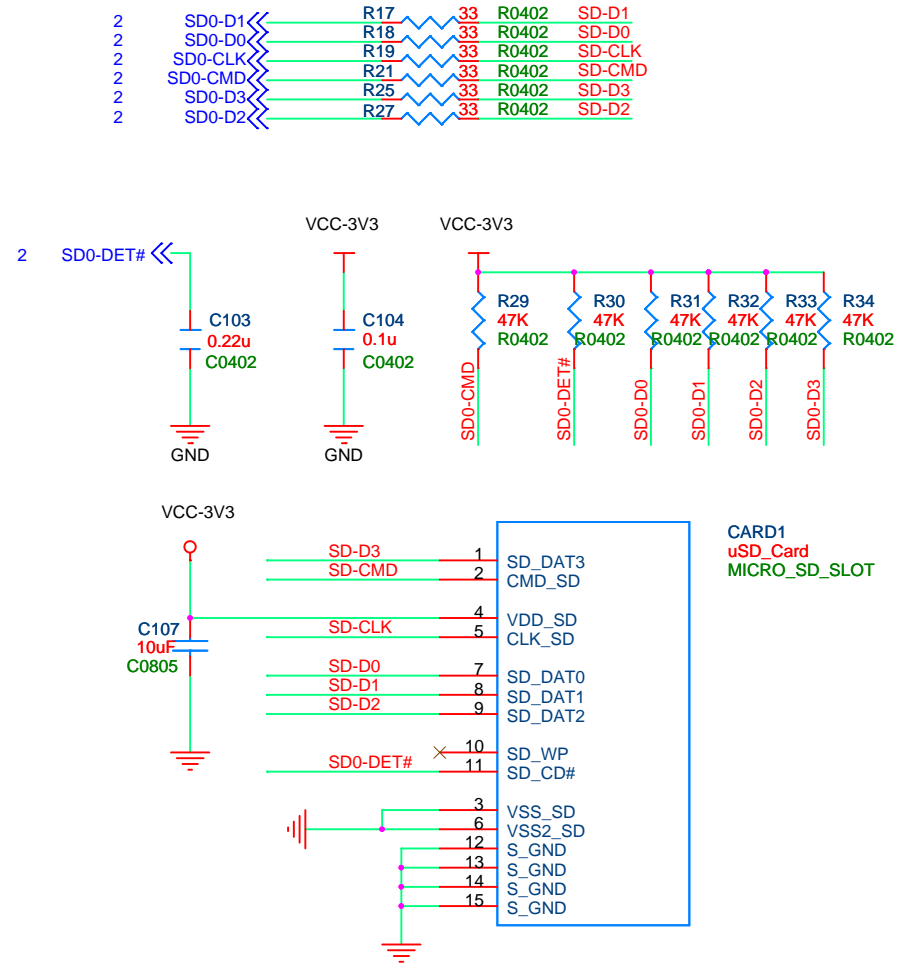

### CARD2 (option with NAND flash)

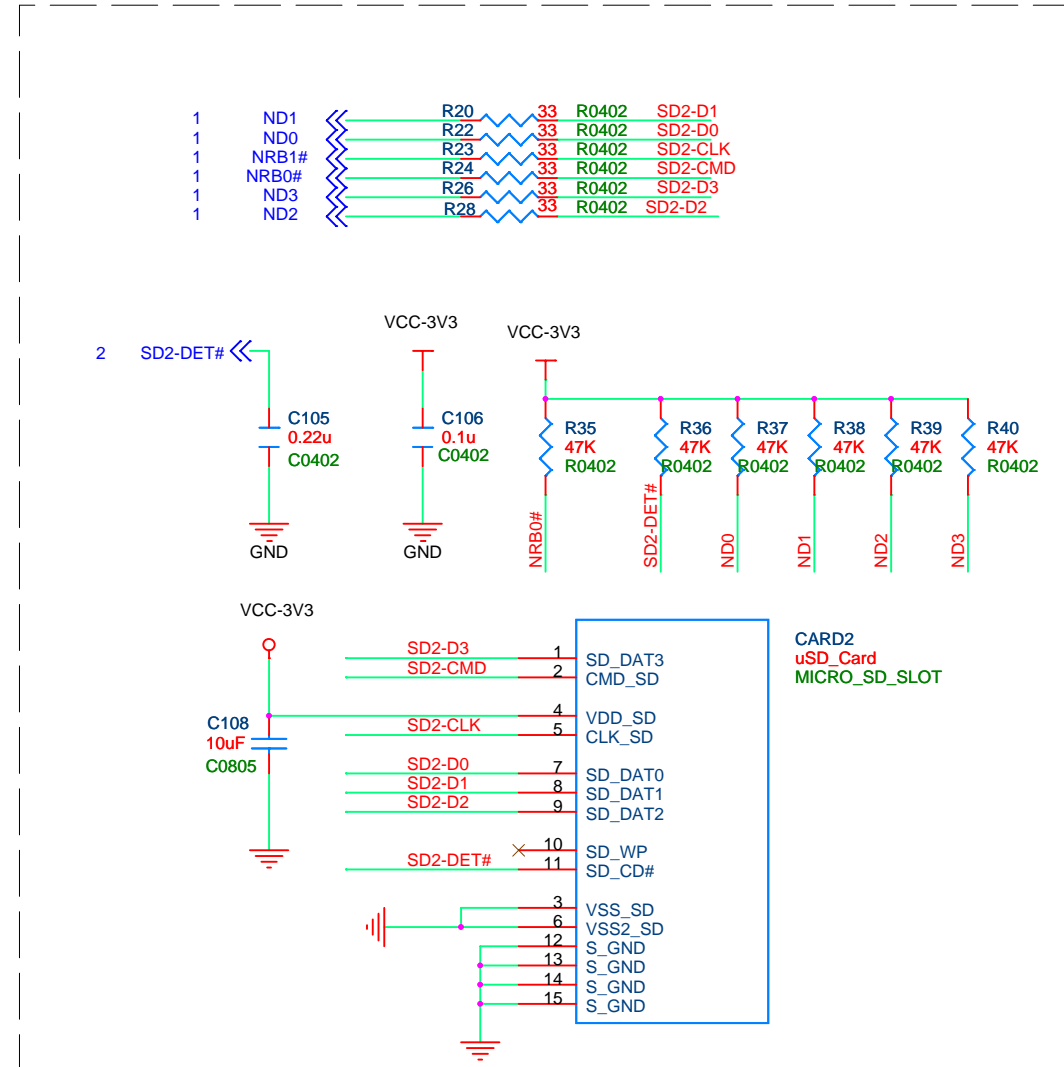

### NAND flash

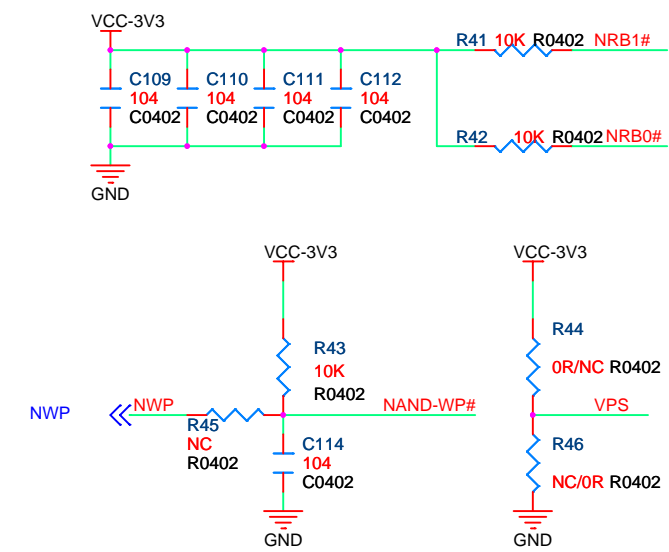
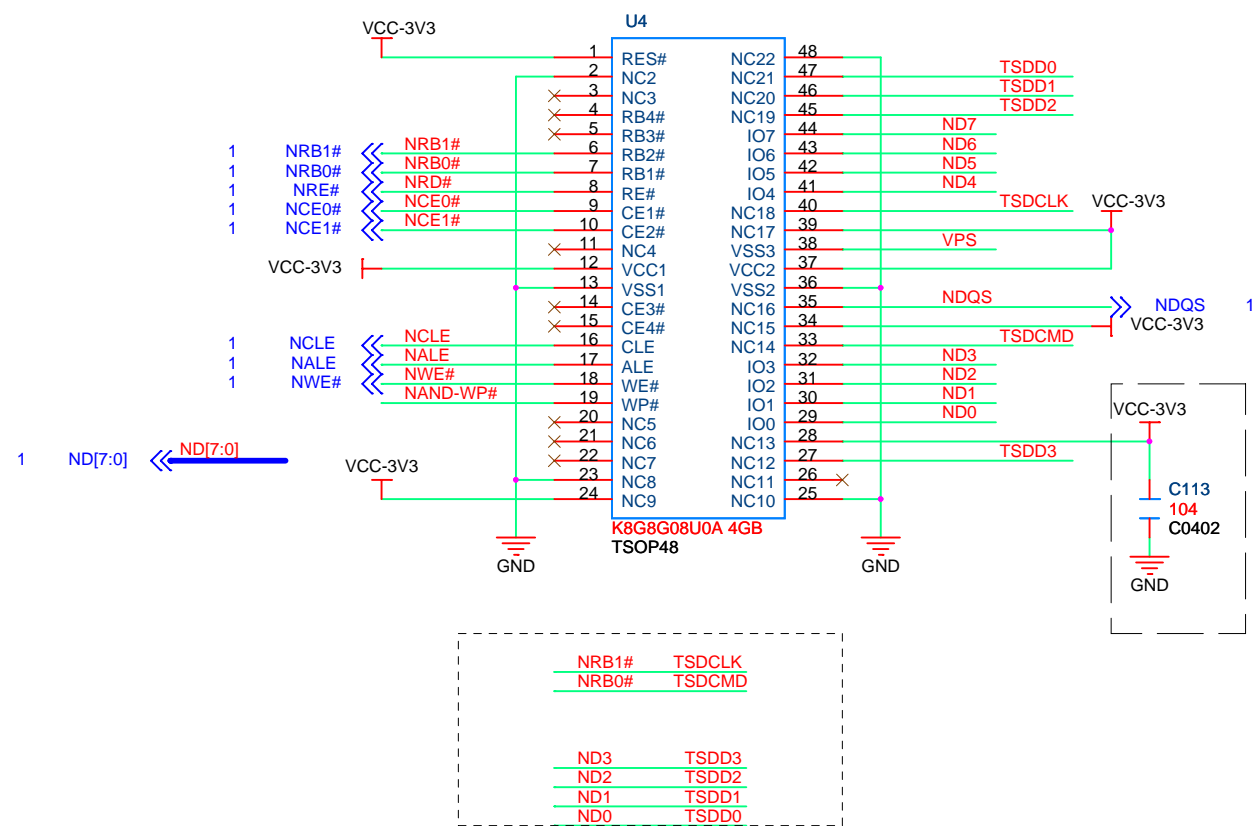

SATA

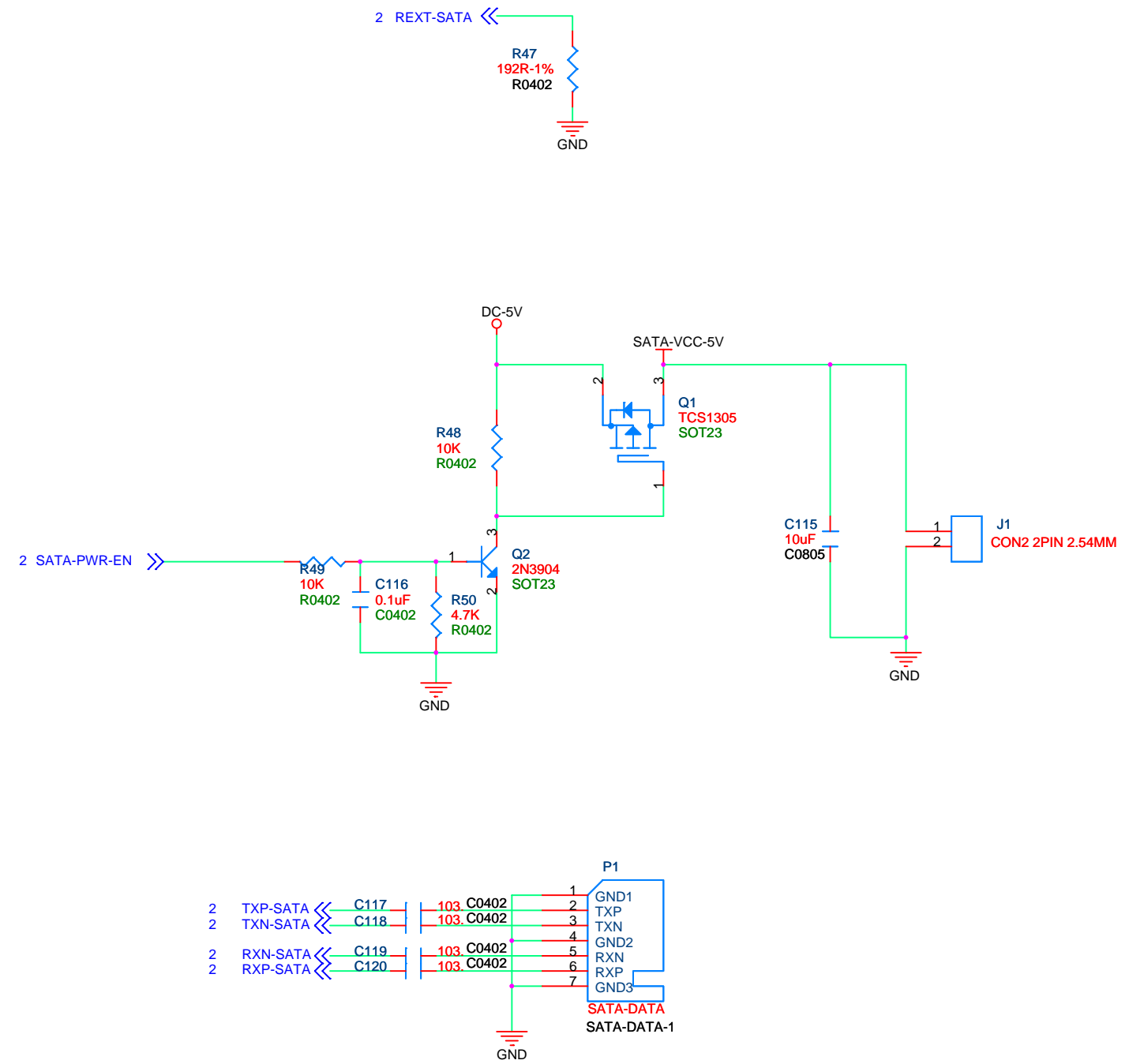



# HDMI

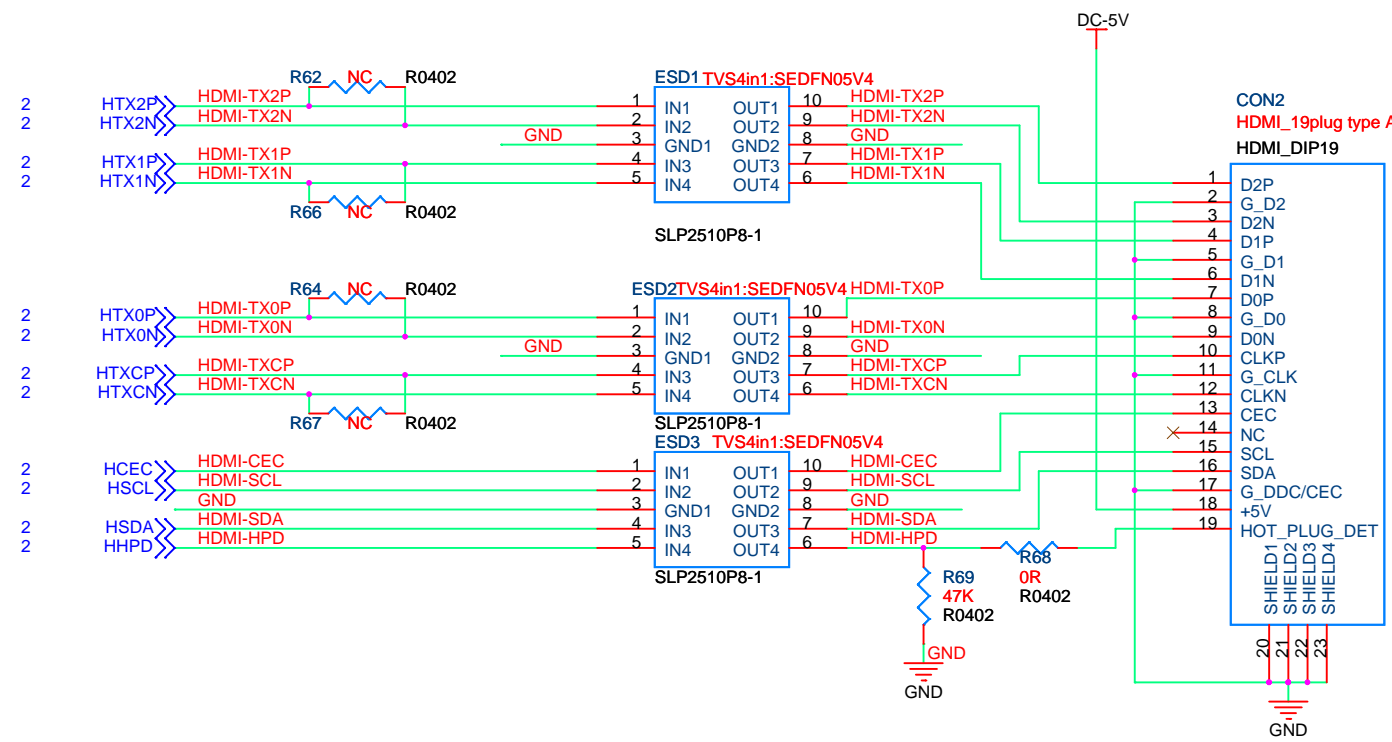

# LEDs

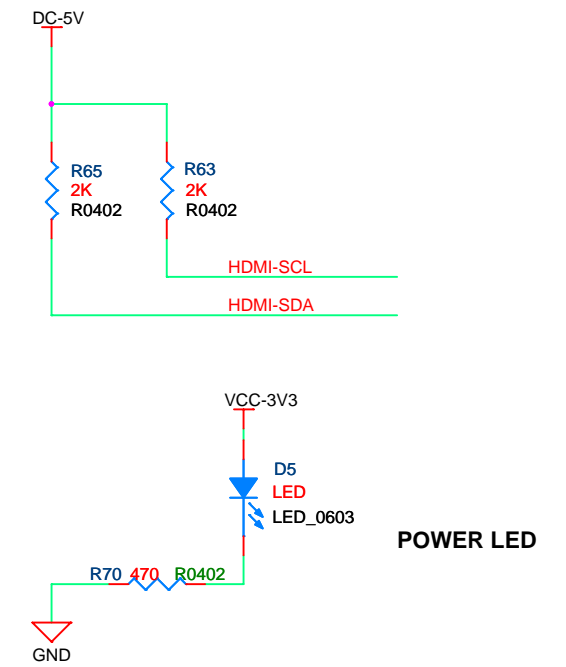

# IR MODULE

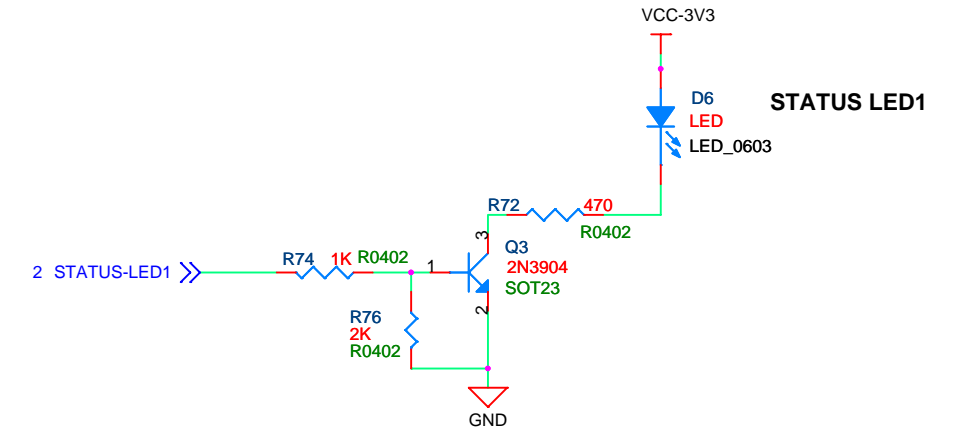
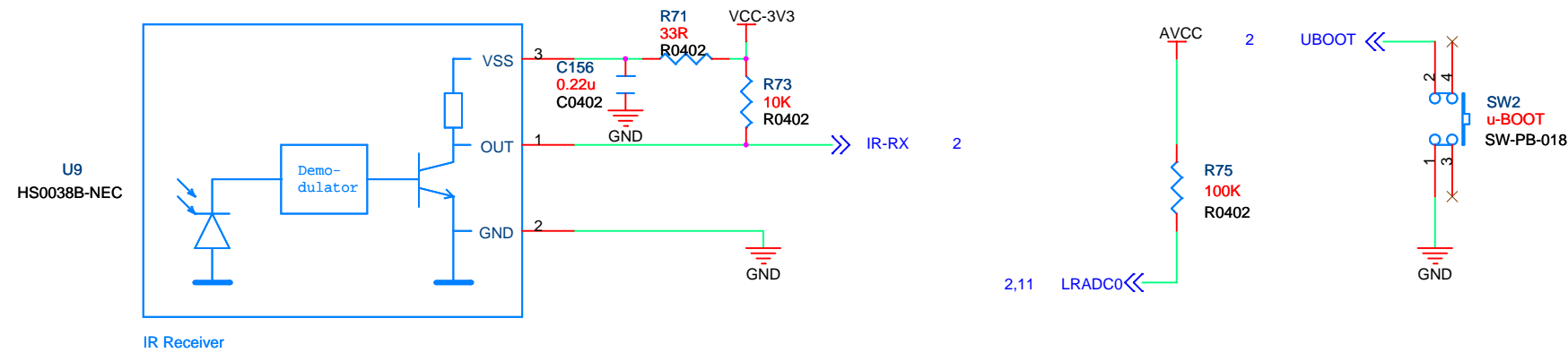

# DEBUG

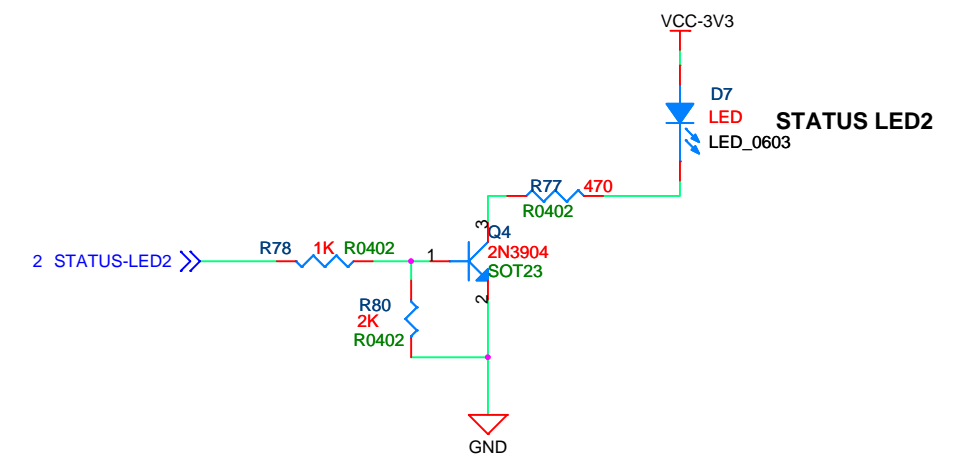
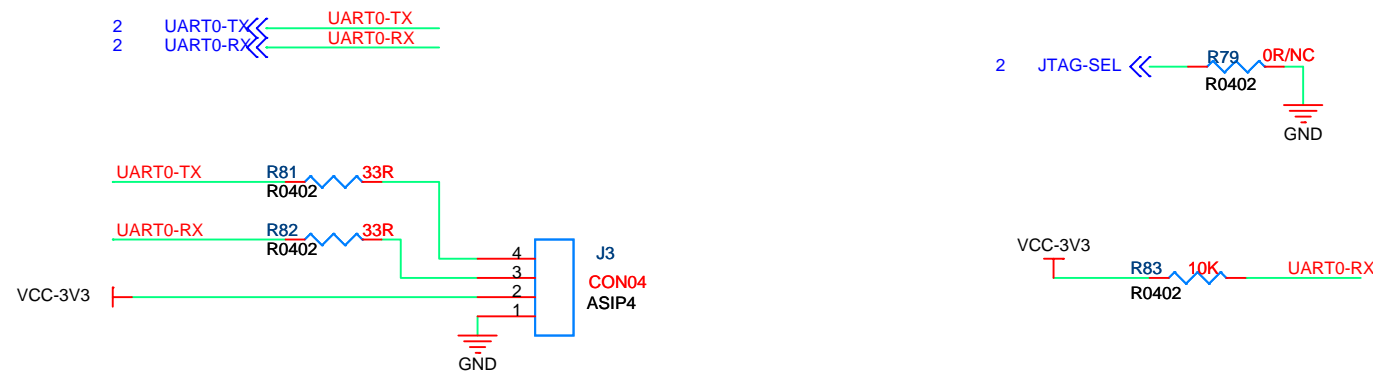

Title		
A10-cubieboard-2012-08-08		
Size	Document Number	Rev
A3	<Doc>	V1.0
Date:	Sheet	8 of 11

# USB HOST x 2

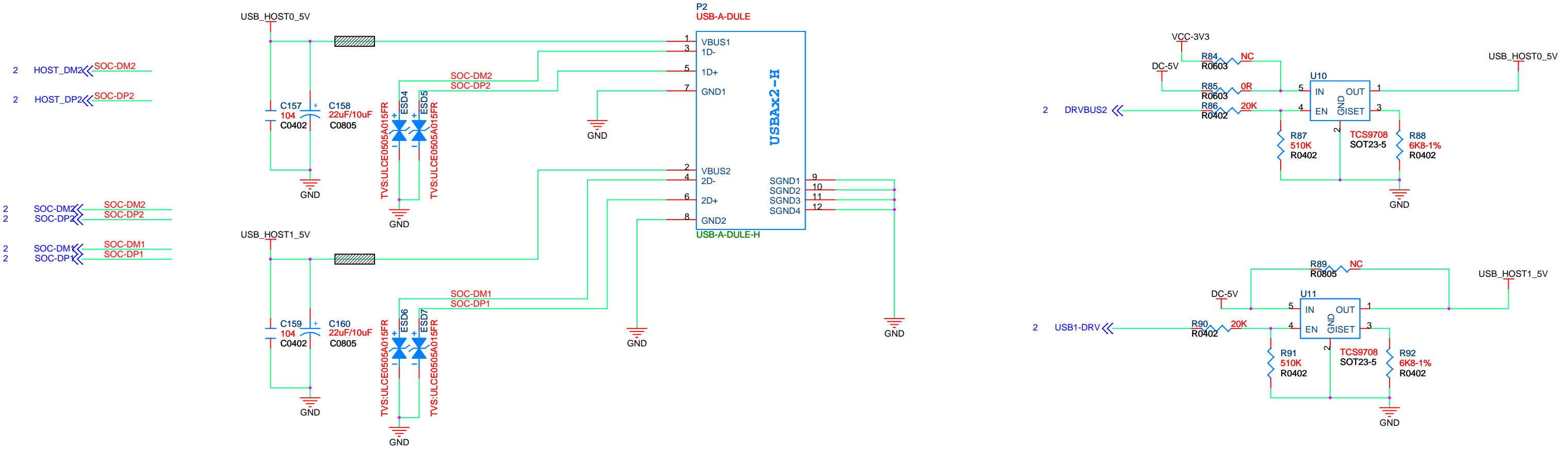

# OTG

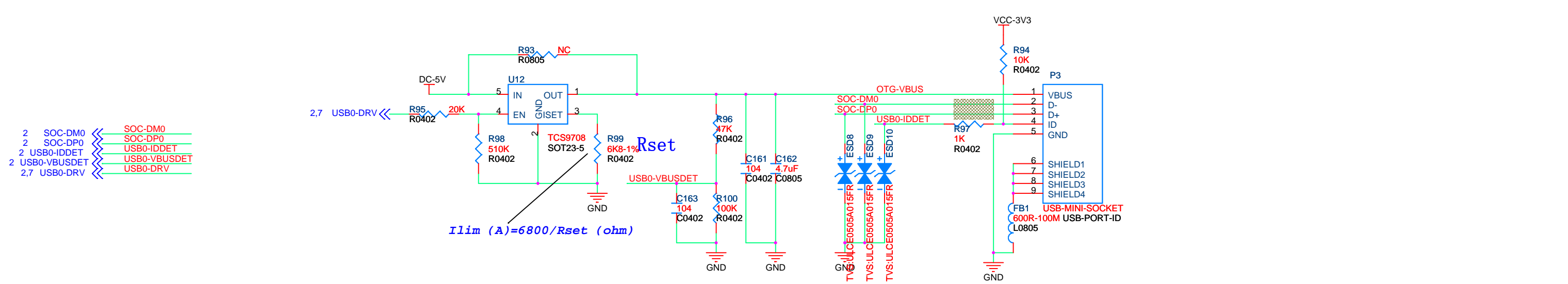

Title		
A10-cubieboard-2012-08-08		
Size	Document Number	Rev
A3	<Doc>	V1.0
Date:	Sheet	9 of 11

# EMAC

- 2 ERXD3 << ERXD3
- 2 ERXD2 << ERXD2
- 2 ERXD1 << ERXD1
- 2 ERXD0 << ERXD0
- 2 ETXD3 << ETXD3
- 2 ETXD2 << ETXD2
- 2 ETXD1 << ETXD1
- 2 ETXD0 << ETXD0
- 2 ERXCK << ERXCK
- 2 ERXERR << ERXERR
- 2 ERXDV << ERXDV
- 2 EMDIO << EMDIO
- 2 ETXEN << ETXEN
- 2 ETXCK << ETXCK
- 2 ECRS << ECRS
- 2 ECOL << ECOL
  
- 2 ETXERR << EPHY-RST#

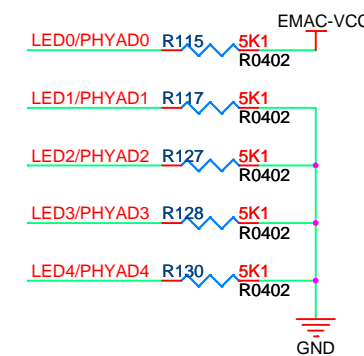
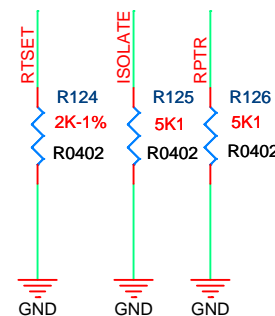
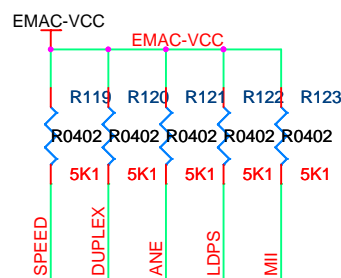
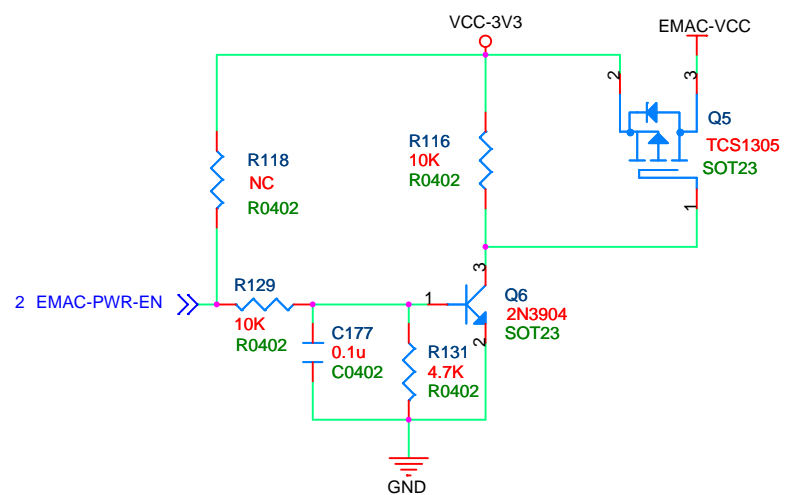
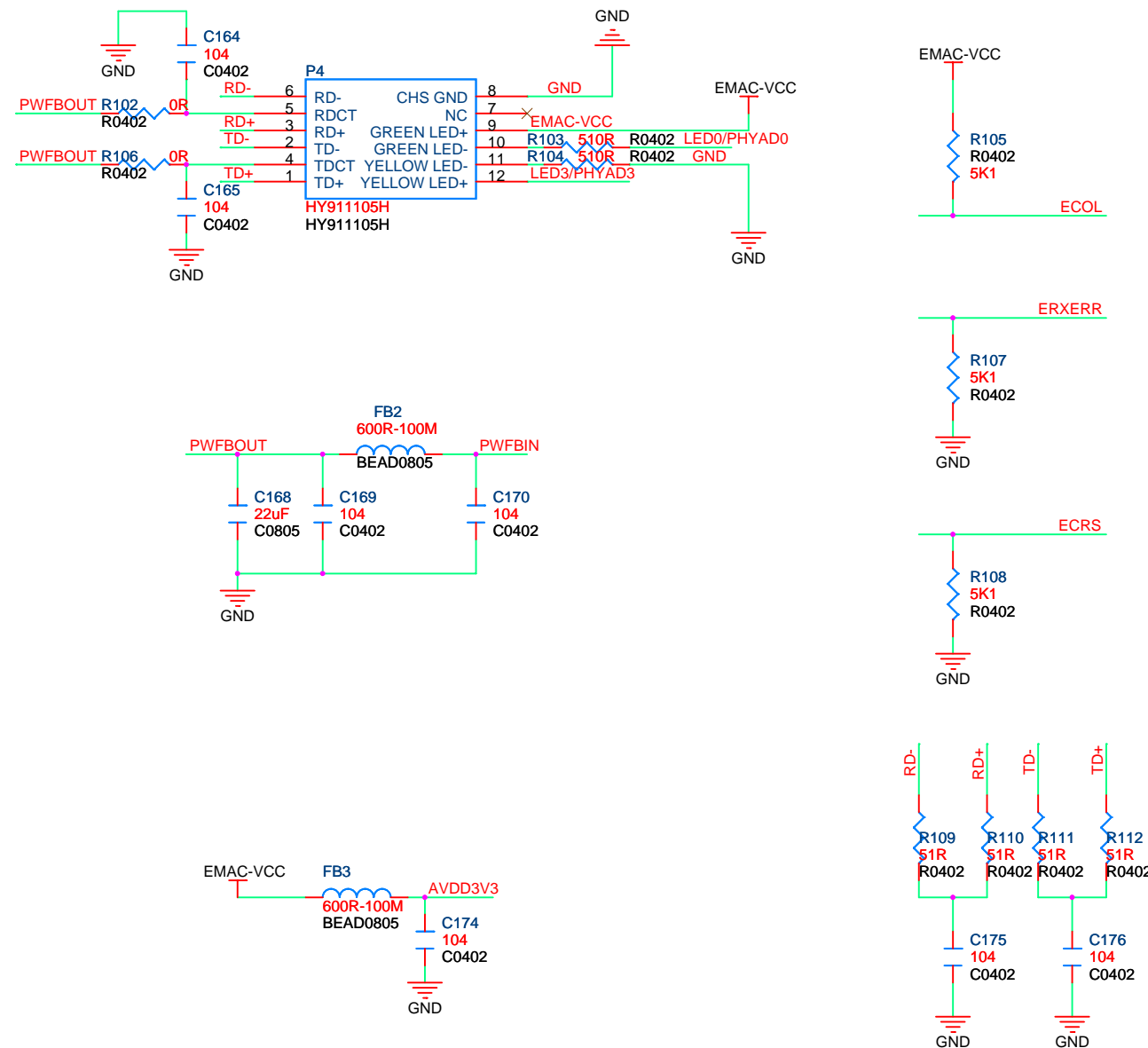
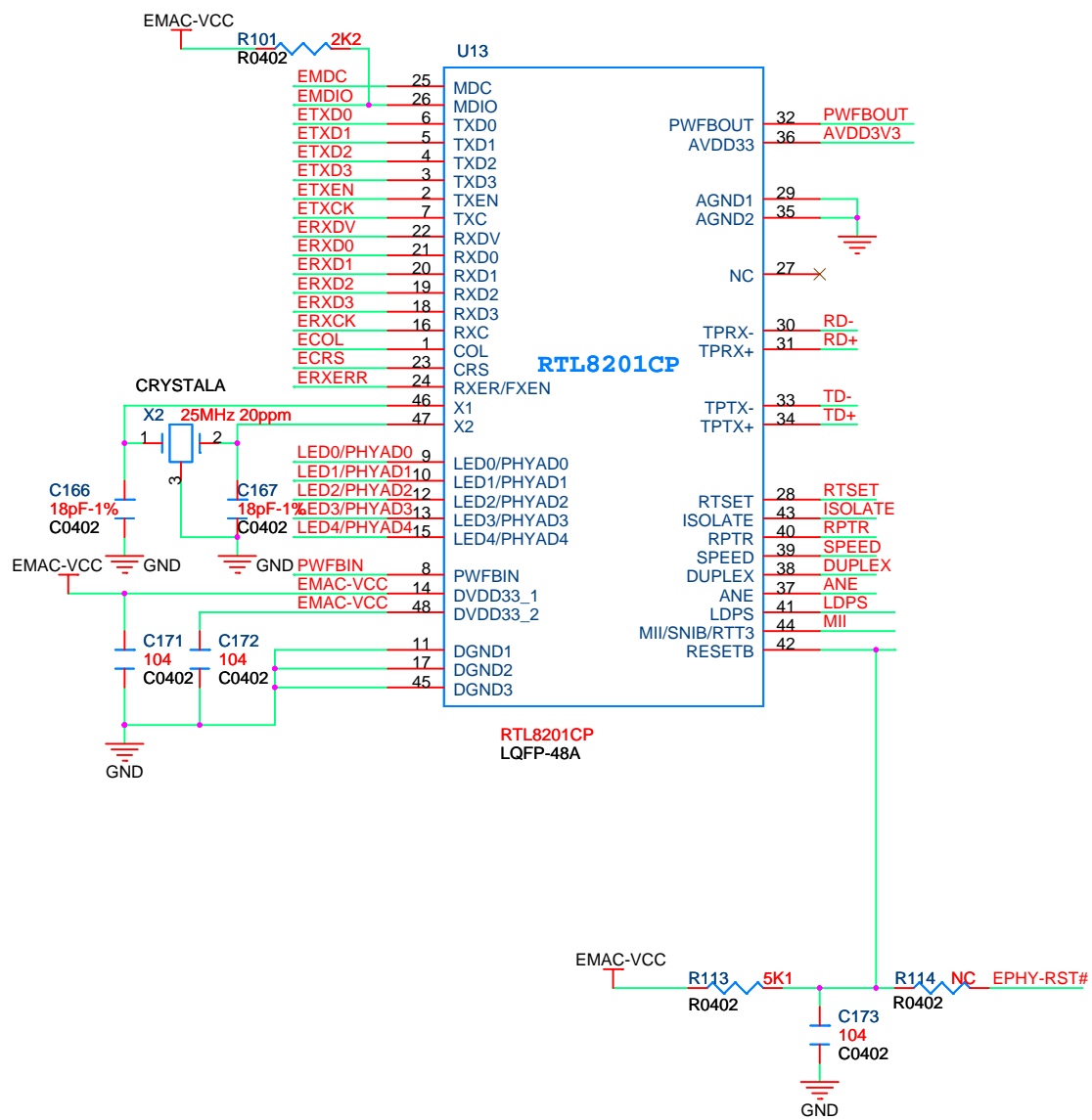

### Extention interface

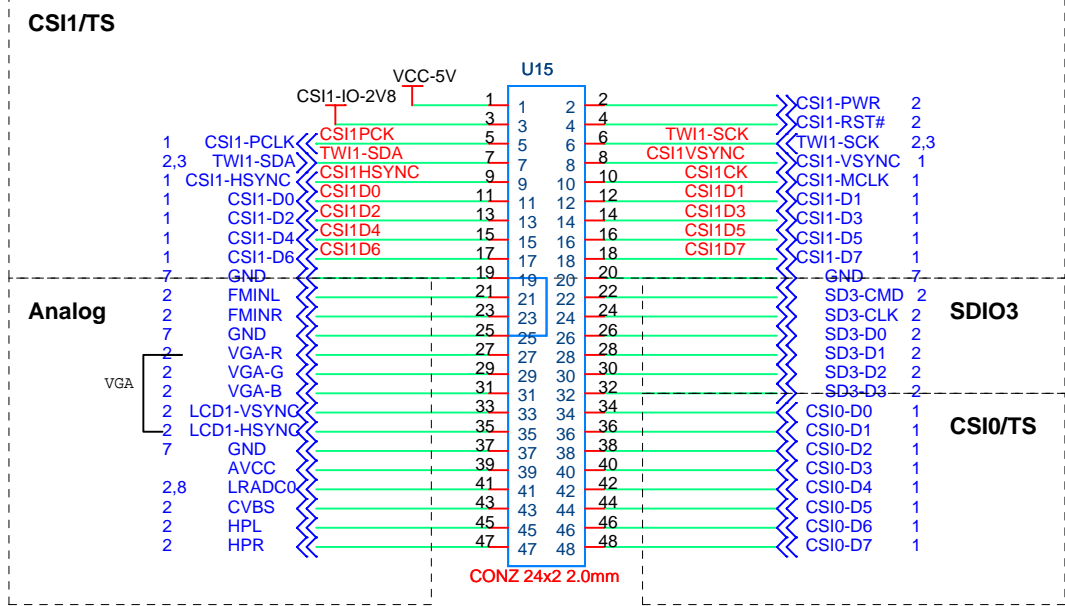
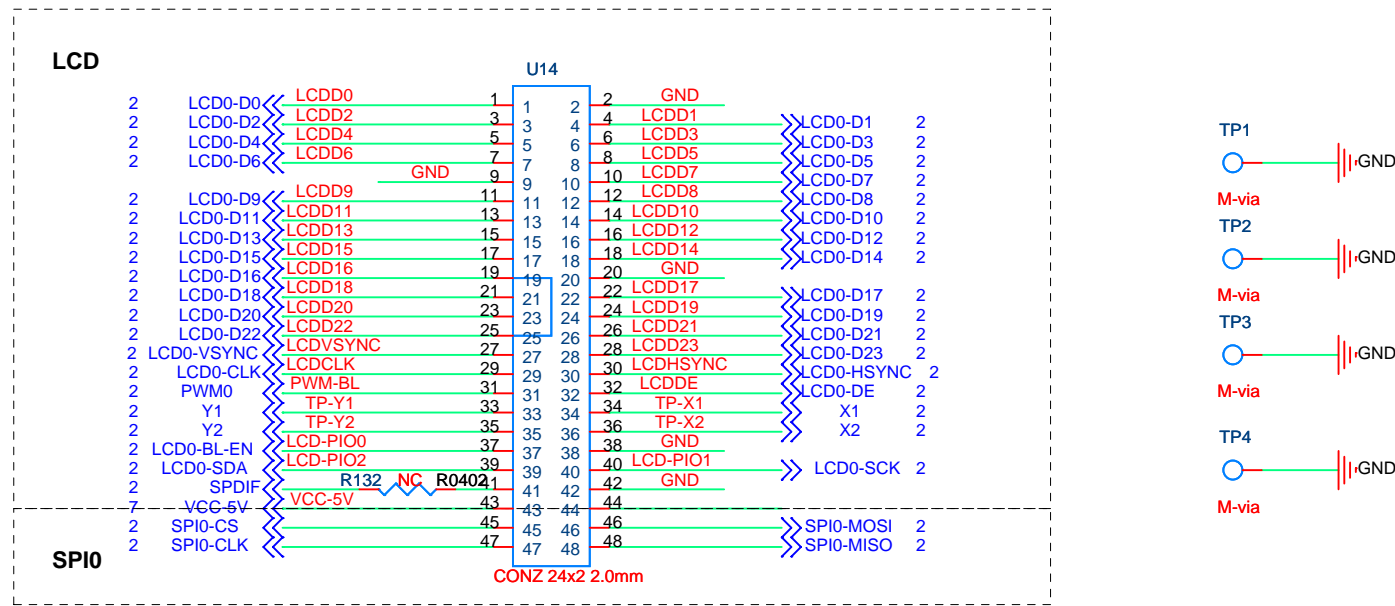

### Line-In

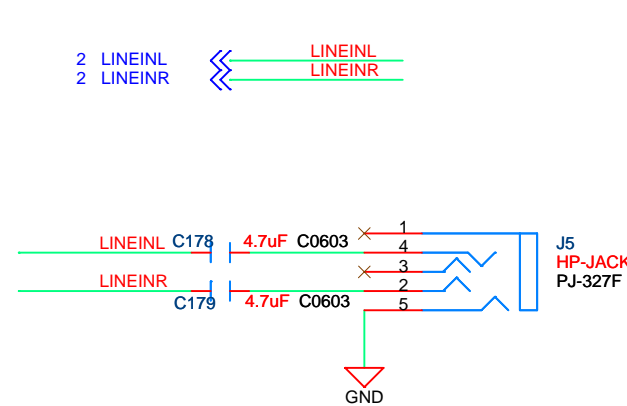

### Head Phone & Speaker

