



Endicott Research Group, Inc.

2601 Wayne St., Endicott, NY 13760

607-754-9187 Fax 607-754-9255

http://www.ergpower.com

SFDMDB3907F



## Specifications and Applications Information

05/27/11

### Smart Force LED Driver

The ERG *Smart Force Series* of LED Drivers are specifically designed for applications which require high efficiency, small footprint and LCD brightness stability over a wide input voltage range. The SFDMDB3907F is designed to provide backlight power for the Optrex T-55563D104J-LW-A-AAN LED and T-55532D104J-LW-A-AAN displays.

Designed, manufactured and supported within the USA, the SFDMD features:

- ✓ Less than 5 mm in height
- ✓ Wide input voltage range
- ✓ Constant LED current
- ✓ With internal dimming signal, up to 255:1 dimming ratio
- ✓ Open and short circuit protection
- ✓ High efficiency
- ✓ Separate enable and dimming function
- ✓ Soft start
- ✓ One year warranty

#### Package Configuration

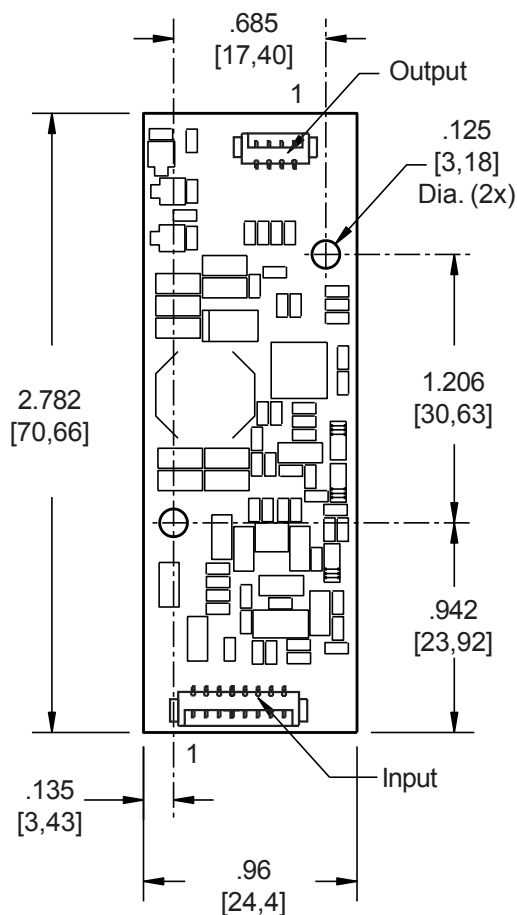

PCB components are shown for reference only. Actual product may differ from that shown.

#### Connectors

Input Connector	Output Connector*
Molex 53261-0871	Molex 53261-0471
J1-1 Vin(+) J1-2 Vin(+) J1-3 GND J1-4 GND J1-5 Enable J1-6 N/C J1-7 Control J1-8 Fault Indicator (output)	J2-1 Cathode 1 J2-2 Anode 1 J2-3 Cathode 2 J2-4 Anode 2
	* Requires harness: ERG part number H12104152 recommended

Mass: 9 grams typ.



**Absolute Maximum Ratings**

Rating	Symbol	Value	Units
Input Voltage Range	$V_{in}$	-0.3 to +20.0	Vdc
Storage Temperature	$T_{stg}$	-40 to +85	°C
Enable Input Voltage	$V_{Enable}$	0 to $V_{in}$	Vdc
Control Input Voltage	$V_{PWM}$	0 to +5.0	Vdc
Fault Indicator	$V_{FL}$	0 to +4.0	Vdc

**Operating Characteristics**

Unless otherwise noted  $V_{in} = 12.00$  Volts dc and  $T_a = 25^{\circ}\text{C}$ .

Characteristic	Symbol	Min	Typ	Max	Units
Input Voltage	$V_{in}$	+8.0	+12.0	+18.0	Vdc
Component Surface Temperature (Note 1)	$T_s$	-40	-	+80	°C
Input Current	$I_{in}$	0.38	0.45	0.52	Adc
LED String Voltage (Note 2)	$V_{LED}$	24.0 (Note 3)	-	38.5	Vdc
Efficiency (Note 4)	$\eta$	-	89	-	%
Output Current (per string)	$I_{out}$	76	80	84	mAdc
<b>Enable Pin</b> (Note 5)					
Turn-on Threshold	$V_{thon}$	-	-	3.5	Vdc
Turn-off Threshold	$V_{thoff}$	0.8	-	-	Vdc
Enable Input Impedance (Note 6)	$R_{Enable}$	-	9.0	-	kOhms
<b>Control Pin</b> (Notes 7,8)					
Full-on Threshold	$V_{thon}$	-	1.0	-	Vdc
Minimum Pulse Width Threshold	$V_{PWmin}$	-	4.5	-	Vdc
Control Input Bias Current	$I_{Cbias}$	-	-	10	uA
Frequency	$F_{PWM}$	-	245	-	Hz

(Operating Characteristics and notes are continued on next page.)



## Operating Characteristics (continued)

Characteristic	Symbol	Min	Typ	Max	Units
<b>Fault Indicator</b>					
No Fault Level (Note 9)	$V_{NFL}$	-	2.5	-	Vdc
Fault Level (Note 9)	$V_{FL}$	-	0.3	-	Vdc

Specifications subject to change without notice.

- Note 1 Surface temperature must not exceed 80°C, except U1, which cannot exceed 95°C.
- Note 2 Exceeding maximum string voltage specification will damage the LED driver.
- Note 3 The LED driver is capable of driving strings less than the minimum string voltage specification, although doing so will limit the maximum input voltage.

To determine max Vin:

$$\text{minimum LED string voltage} \geq (1.3) \times (V_{in \text{ maximum}})$$

- Note 4 Efficiency is calculated using a 30V LED string.
- Note 5 The Enable pin is internally pulled up above the turn-on threshold.
- Note 6 Enable pin input impedance is 9kΩ to 8V with a 12V input voltage.
- Note 7 Control pin is internally pulled up above the turn-on threshold.
- Note 8 Control pin input impedance is 485kΩ.
- Note 9 Loading with an impedance less than 100kΩ to Vcc or to ground may cause the default levels to change.



## Application Information

The ERG SFDMDB3907F has been designed to be configured in multiple ways:

### NO DIMMING

- OPERATION: The SFD can be configured to operate without dimming by floating the Enable (J1-5) and Control (J1-7) pins.
- Pins 1 and 2 of connector J1 must be connected to +Vin, between 8 and 18 Vdc. Pins 3 and 4 of connector J1 must be connected to GND.
- DISABLING DRIVER: Pulling the Enable pin (J1-5) below the minimum turn-off threshold of 0.8V will disable the driver. Disabling the driver will require the ability to sink  $\geq 2\text{mA}$  below the turn-off threshold. This pin may be driven by an open collector stage or a totem pole stage.

### ONBOARD PWM DIMMING

- OPERATION: Onboard PWM configuration as shown in Figure 1 allows the user to control display brightness by controlling the onboard PWM generator. The user is responsible to provide an analog control signal. A dimming ratio up to 255:1 is possible with this configuration.
- DIMMING: Dimming is accomplished by applying an analog voltage to the Control Pin (J1-7). Display brightness is modulated by controlling the Control Pin voltage as shown in Graph 1.
- ENABLE/DISABLE: The driver may be enabled or disabled (turned on and off) by applying a DC voltage to the Enable Pin (J1-5). Enable Pin on and off levels are specified in the Operating Characteristics section of the data sheet. The driver can also be enabled by floating the Enable Pin.
- Pins 1 and 2 of connector J1 must be connected to +Vin, between 8 and 18 Vdc. Pins 3 and 4 of connector J1 must be connected to GND.

### FAULT INDICATOR

- The Fault Indicator pin (J1-8) may be used as a feedback signal that will fall below the fault level of 0.3V in the case of an open string, a shorted string, an output overvoltage condition, or an over temperature condition. If used, this pin should be loaded with a high impedance stage as specified in the Operating Characteristics. Do not drive this pin with a voltage, as it will damage the driver.



## ONBOARD PWM DIMMING

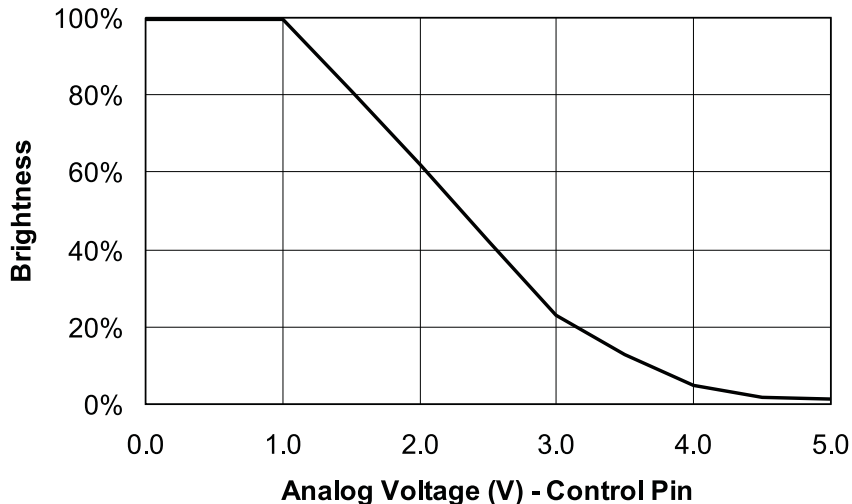

Graph 1

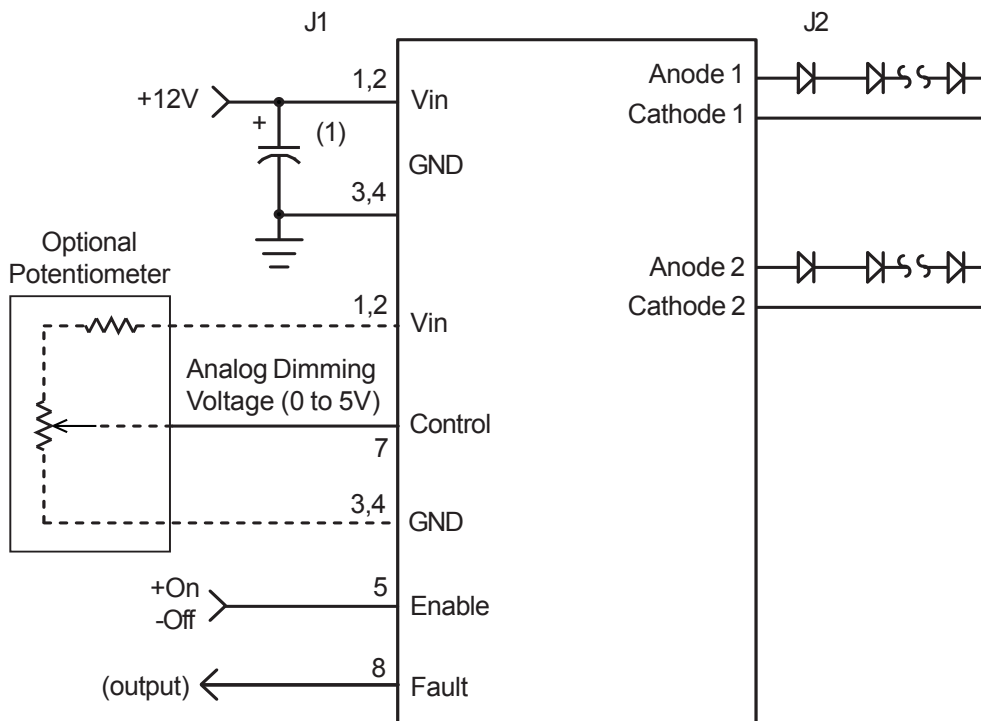

Figure 1

- (1) Low ESR type input by-pass capacitor (10 uF - 220 uF) may be required to reduce reflected ripple and to improve power supply response.



Endicott Research Group, Inc. (ERG) reserves the right to make changes in circuit design and/or specifications at any time without notice. Accordingly, the reader is cautioned to verify that data sheets are current before placing orders. Information furnished by ERG is believed to be accurate and reliable. However, no responsibility is assumed by ERG for its use.