



Endicott Research Group, Inc.

2601 Wayne St., Endicott, NY 13760

607-754-9187 Fax 607-754-9255

http://www.ergpower.com

Specifications and Applications Information

09/30/08

The ERG **SFWSeries** of DC to AC inverters is specifically designed for applications which require high efficiency, wide dimming and LCD brightness stability over a wide input voltage range.

Designed, manufactured and supported within the USA, the SFW series features:

- ✓ Less than 6mm in Height
- ✓ Onboard regulation of lamp current
- ✓ High efficiency
- ✓ Open lamp detection
- ✓ Onboard PWM dimming
- ✓ Support for a wide range of displays
- ✓ Low EMI emission

SFWA160J

Smart Force™ Single Lamp Inverter



Package Configuration

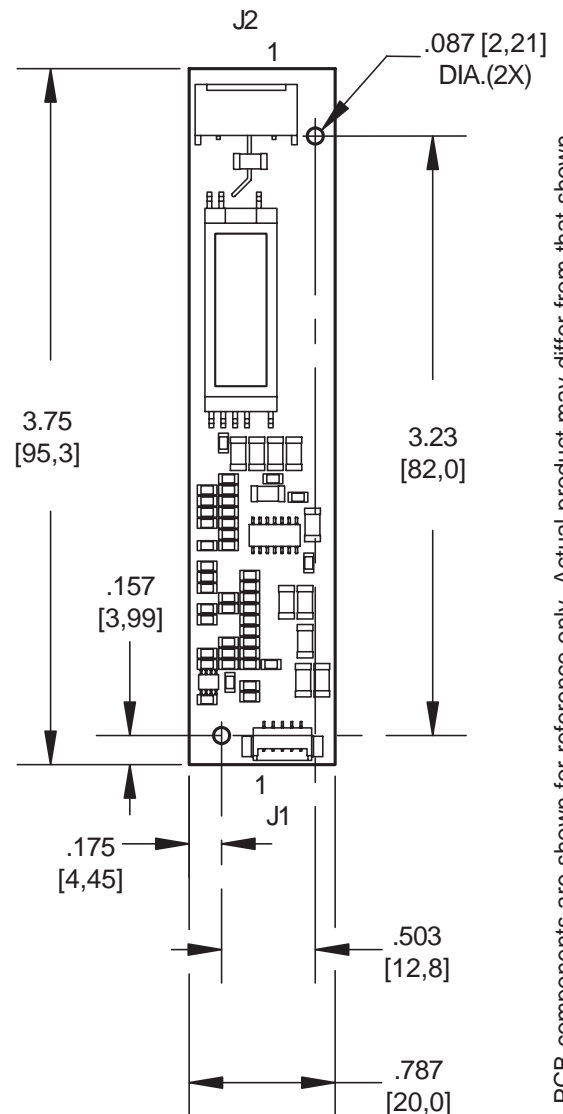

PCB components are shown for reference only. Actual product may differ from that shown.

Connectors

Input Connector	Output Connector
Molex 53261-0571	JST SM02(8.0)B-BHS-1-TB
J1-1 +Vin J1-2 GND J1-3 Enable J1-4 Control J1-5 N/C	J2-1 ACout J2-2 ACreturn

**Absolute Maximum Ratings**

Rating	Symbol	Value	Units
Input Voltage Range	V_{in}	-0.3 to +21.0	Vdc
Enable	V_{Enable}	-0.3 to V_{in}	Vdc
Control	$V_{Control}$	-0.3 to +5.5	Vdc
Ambient Operating Temperature	T_a	-20 to +85	°C
Storage Temperature	T_{stg}	-40 to +85	°C

Operating Characteristics

Unless otherwise noted $V_{in} = 12.0$ Vdc, $T_a = 25^\circ\text{C}$, with a simulated load and unit has been running for 5 minutes.

Characteristic	Symbol	Min	Typ	Max	Units
Input Voltage ^(note 1)	V_{in}	+8.0	+12.0	+18.0	Vdc
Input Current ^(note 2)	I_{in}	-	0.43	0.49	Adc
Operating Frequency	F_o		62		kHz
Minimum Output Voltage ^(note 3)	$V_{out (min)}$	1800	-	-	Vrms
Efficiency ^(note 4)	h	-	85	-	%
Output Current (per lamp) ^(note 5)	I_{out}	-	6.0	-	mArms
Output Voltage ^(note 6)	V_{out}	-	-	780	Vrms
Enable Pin					
Turn-off Threshold	V_{thoff}	GND	-	0.5	Vdc
Turn-on Threshold	V_{thon}	2.4	-	V_{in}	Vdc

Specifications subject to change without notice.

(Note 1) V_{in} is measured at the pcb connector.

(Note 2) Input current in excess of maximum may indicate a load/inverter mismatch condition, which can result in reduced reliability. Please contact ERG technical support.

(Note 3) Provided data is not tested but guaranteed by design.

(Note 4) 730 Vrms lamp voltage used in efficiency calculation.

(Note 5) The output current is measured from the AC return lead of the inverter using a Tektronix CT-2 AC current probe terminated into 50 ohms at the oscilloscope input.

(Note 6) Max allowable lamp voltage.



Onboard PWM

Unless otherwise noted $V_{in} = 12.0 \text{ Vdc}$, $T_a = 25 \text{ }^\circ\text{C}$ and unit has been running for 5 minutes.

Characteristic	Symbol	Min	Typ	Max	Units
Frequency	f_{pwm}	-	290	-	Hz
Minimum Brightness	V_{control}	-	4.0	-	V
Maximum Brightness	V_{control}	-	1.3	-	V

Pin Descriptions

- Vin** Input voltage to the inverter.
- GND** Inverter ground.
- Control** Analog voltage input to the onboard pulse width modulator. Graph 1 shows the relationship between V_{control} and relative display brightness.
- Enable** Inverter Enable.

Application Information

The SFW series of inverters is designed to power one cold cathode fluorescent lamp from a nonregulated DC power source. Enabling the inverter is accomplished by applying a voltage greater than V_{thon} to the Enable pin of the inverter.

Dimming the inverter is accomplished by applying a DC voltage to the Control pin. The applied DC voltage adjusts the duty cycle of the onboard PWM controller thereby changing the brightness of the backlight. Graph 1 shows the typical brightness versus voltage applied to the control pin.

As with all inverters, it is important to take notice that the voltage present at the output pins is quite high and requires special care to be taken when integrating into the final application. The inverter should not be mounted closer than 0.250" (6.4mm) to any other conductive material. In general, the mounting hardware should be nonconductive. Open frame inverters, like the SFW, are not recommended in applications which require operation above 10,000 feet (3000 meters).

To improve the electrical efficiency of the overall application, the input harness cabling should be less than 12 inches (30 cm). The cable assembly between the inverter and the display is best kept below 4 inches (10 cm). If there are any questions or concerns, please feel free to contact ERG for exceptions or recommendations.



Relative Brightness vs Control Voltage

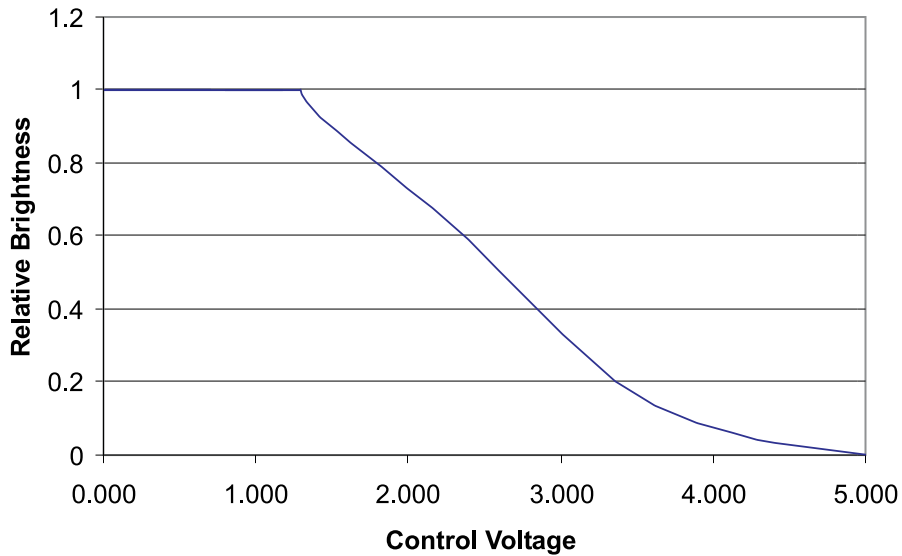

Graph 1

Typical Application

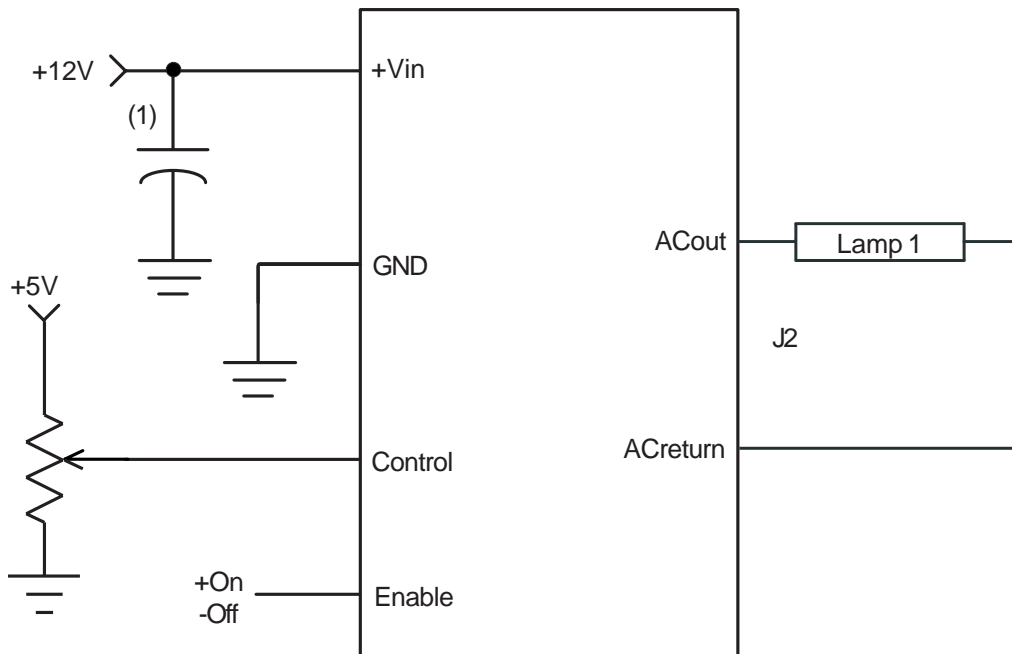

Figure 1

(1) Low ESR type input by-pass capacitor (22 μ F - 220 μ F) may be required to reduce reflected ripple, and to improve power supply transient response.



Endicott Research Group, Inc. (ERG) reserves the right to make changes in circuit design and/or specifications at any time without notice. Accordingly, the reader is cautioned to verify that data sheets are current before placing orders. Information furnished by ERG is believed to be accurate and reliable. However, no responsibility is assumed by ERG for its use.