

ACCESSORIES

Model SYS-CS1

System 84 Control Interface

ANYWHERE YOU NEED...

- RS-232 Control of System 84
- Serial Control of Audio Matrix
- Control of Eight VCA Modules
- Status Inputs from Eight Sources
- An Interface with Front Panel Indicators
- A Free-Standing or Rack-Mounted Interface



You Need The SYS-CS1!

The SYS-CS1 is a chassis based interface that can be used free-standing or rack-mounted with other RACK-UP products from Radio Design Labs. For rack-mounted installations, the SYS-CS1 uses two RACK-UP mounting bays in an RDL RU-RA3 rack mount frame.

APPLICATION: The SYS-CS1 controls all 32 switching functions of an RDL System 84 audio mixing matrix. It also provides 8 separate **ZERO TO 10 VOLT OUTPUTS** to control external VCAs or other equipment with 0 to 10 VDC control inputs. Eight **STATUS INPUTS** are provided for sensing external switch or transistor closures.

The SYS-CS1 connects to a computer through an RS-232 serial link. Commands may be initiated from a terminal program or from user software that sends and receives commands detailed in the instruction manual.

OUTPUT TERMINAL COMMANDS – A command will either select or deselect each of the eight System84 inputs to any of the four outputs. A separate command deselects all 32 switching functions thereby turning off all inputs to all outputs.

0 TO 10 VOLT OUTPUT COMMANDS – The ramp rate for each output can be preset individually or globally. Output commands then initiate a ramp from the present level to a newly defined level. The output level (one or all) may also be sent directly to a new level without ramping. A separate command will set the SYS-CS1 to report the completion of ramping. If any 0 to 10 VDC output is used to control other equipment that uses 0 to 5 VDC control, the corresponding SYS-CS1 output may be set to output 0 to 5 VDC without any loss of resolution.

STATUS INPUT TERMINAL COMMANDS – The SYS-CS1 may be set to provide an alert any time an individual status input terminal changes state (low to high, high to low). Global commands allow enabling or disabling alerts from all status inputs. The controlling computer can also query the status of an individual terminal or all status terminals. A separate command allows the program to provide an alert when a defined pattern of all eight status terminals occurs.

The SYS-CS1 may be operated solely to control the System 84 without any response codes fed back to the computer. An initialization command sets all parameters to known values at the beginning of the user program. Error codes may be enabled to assist in development of controlling software. A pair of RDL RU-SC2 modules may be used to locate the controlling computer at a location remote from the SYS-CS1.

Front panel LEDs show any active audio outputs, active status inputs, transmit and receive data, errors and power. The SYS-CS1 operates from 24 VDC which may be connected either through the DC power jack or terminal block.



RDL
Radio Design Labs

SPECIALISTS IN PRACTICAL PRECISION ENGINEERING™



RACK-UP® SERIES

Model SYS-CS1 System 84 Control Interface

Installation/Operation



EN55103-1 E1-E5; EN55103-2 E1-E4
Typical Performance reflects product at publication time exclusive of EMC data, if any, supplied with product. Specifications are subject to change without notice.

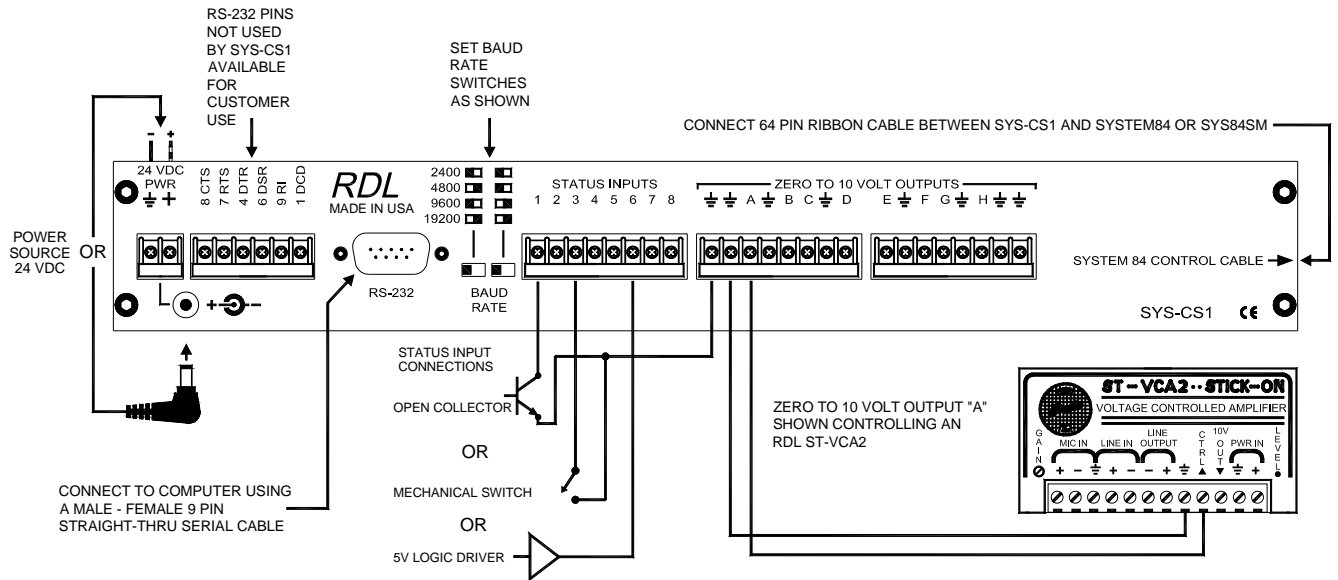
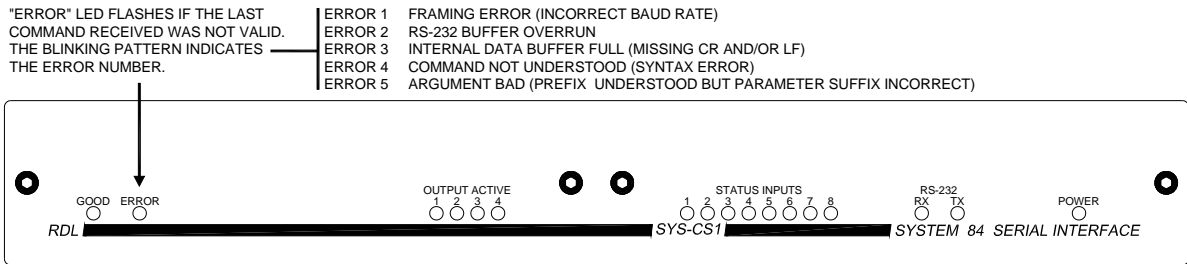

TYPICAL PERFORMANCE

Control Input / Output:
Control Outputs (32):
Status Inputs (8):

0 to 10 VDC Outputs (8):
Ramp Rate for 0 to 10 V Outputs:

Power Requirement:

RS-232 (DB-9 female jack)
Open-collector on 64-pin header
Low = active
(internally pulled high to 5 VDC); MAX input 24 VDC
22 Ω ground-referenced, 20 mA, 256 steps
0.5 to 120 seconds
(for 10 V change), individually programmable
24 to 33 Vdc @ 150 mA, Ground-referenced

NOTE: This equipment has been tested and found to comply with the limits for a Class B digital device, pursuant to part 15 of the FCC Rule. These limits are designed to provide reasonable protection against harmful interference in a residential installation. The equipment generates, uses and can radiate radio frequency energy and, if not installed and used in accordance with the instructions, may cause harmful interference to radio communications. However, there is no guarantee that interference will not occur in a particular installation. If this equipment does cause harmful interference to radio or television reception, which can be determined by turning the equipment off and on, the user is encouraged to try to correct the interference by one or more of the following measures:

- Reorient or relocate the receiving antenna
- Increase the separation between the equipment and receiver
- Connect the equipment into an outlet on a circuit different from that which the receiver is connected.
- Consult the dealer or an experienced radio/TV technician for help.

Radio Design Labs Technical Support Centers
U.S.A. (800) 933-1780, (928) 778-3554; Fax: (928) 778-3506
Europe [NH Amsterdam] (+31) 20-6238 983; Fax: (+31) 20-6225-287