



AIRPAX® | 5020 Series
HERMETICALLY SEALED THERMOSTAT PROBE

FEATURES

- RoHS compliant per EU directive 2002 / 95 / EC
- 1/2" disc button style
- Hermetic glass seal, grounded-case only
- Ideal for immersion sensing

DESCRIPTION

The Airpax™ 5020 series is a single throw, snap-action, hermetically sealed temperature control designed for applications requiring high vibrational resistance. The snap-action disc is located in the very tip of the probe, assuring rapid and true response to temperature. The welded construction (and grounded case) of this sealed thermostat ensures meeting thermal shock specifications of MIL-STD-202, method 107, test condition B. In addition, the tube will withstand a pressure exposure limit of 1500 PSI.

Typical applications include hydraulic systems, degreasers, industrial and portable compressors, refrigeration systems, generator sets, chemical baths, engine coolant, oil and transmission protection.

SPECIFICATIONS				
Contact Ratings	<i>Cycles</i> 100,000	<i>Voltage</i> 12 or 32 VDC	<i>Amps</i> 3 (resistive)	<i>Case Type</i> grounded case
Contact Operations	Either close on rise (make) or open on rise (break), SPST (Single Pole, Single Throw)			
Operating Temperature	+35°F to 480°F (+1.67°C to 249°C)			
Dielectric Strength	500 VAC, 60Hz (grounded case) terminals to case across open contacts			
Vibration	.06DA, 10-55 Hz, 20G 20-2000 Hz			
Shock	.75G 6ms duration (sawtooth)			
Military Specifications	5020-13 conforms to MIL-S-12285/1, thermal shock per MIL-STD-202, Method 107, Condition B			
Materials	Stainless steel body and tube, compression glass seal, Mylar sleeve, epoxy fill potting, stainless or plated steel terminals, fine silver contacts			

1. CONTACT OPERATION

CODE	DESCRIPTION
O	Letter "O" = Open on Rise
C	Letter "C" = Close on Rise

To build your part number (PN), choose the proper codes from pages 2 to 4.

Consult Sensata Technologies when a code Z is used to indicate a special requirement. Sensata will assign a unique, customer-specific four digit nondescript number. To complete the customer specific part number build, replace the bottom temperature and tolerance (codes 7 & 8) after the "-" dash with the assigned four digit nondescript.

2. TERMINAL SELECTION

<p>A</p> <p>#8-32 Pan Head Screw #7 Lock Washer (Packaged in plastic bag)</p> <p>Mounting Encapsulated</p>	<p>B</p> <p>Quick Connect (6.35) / 0.250</p> <p>Mounting Encapsulated</p>	<p>C</p> <p>#8-32 Hex Nut #8 Lock Washer (Packaged in plastic bag)</p> <p>Mounting Encapsulated</p>	<p>D</p> <p>Connector MS3380 To Mate with Male Connector MS27144</p> <p>Mounting Encapsulated</p>	<p>E</p> <p>#10-32 Hex Nut #10 Lock Washer (Packaged in plastic bag)</p> <p>Mounting Encapsulated</p>
<p>F</p> <p>Lead Wire (152.40 ± 25.40) / 6.000 ± 1.00 Strip (6.35) / .250</p> <p>Mounting Encapsulated</p>	<p>G</p> <p>Same as terminal selection "F"</p> <p>Except 1 Lead (304.80 ± 25.40) / 12.00 ± 1.00</p> <p>See note 1 for lead specifications</p>	<p>H</p> <p>Same as terminal selection "F"</p> <p>Except 1 Lead (609.60 ± 25.40) / 24.00 ± 1.00</p> <p>See note 1 for lead specifications</p>	<p>J</p> <p>Same as terminal selection "F"</p> <p>Except 1 Lead (1219.20 ± 25.40) / 48.00 ± 1.00</p> <p>See note 1 for lead specifications</p>	<p>Z</p> <p>Special Requirements Customer to Specify</p>

- The standard lead wire (materials) for different temperature ranges are as follows:
 - Up to 220°F (104.4°C) = # 18 AWG stranded. UL Style 1015/CSA approved. (PVC insulation, color black)
 - 221°F to 350°F (105°C to 176.6°C) = #18 AWG stranded. UL Style 1199/CSA approved. (Teflon® TFE insulation, color black)
 - 351°F (177.2°C) and above = #18 AWG stranded. UL style 5288/CSA approved. (Composite of Teflon®, ceramic + glass braid, color brown)
- The marking information on each thermostat will include either the name Sensata or Airpax, contact operation (CLR) close on rise, (OPR) open on rise, top temperature and date code.

EXAMPLE : C20ABC285C-245Y

Close contacts on temperature rise, 5020 series, grounded case 8-32" screw terminal, 1/2-14 PTF threads, 1.635" tube length, 285°F top temperature with a ±8°F standard top tolerance and a standard 40°F differential between top and bottom temperature for temperature range of 251°F to 400°F, differential helps calculate a bottom temperature of 245°F with a standard minimum reset for contacts to close at or above the bottom temperature set point.

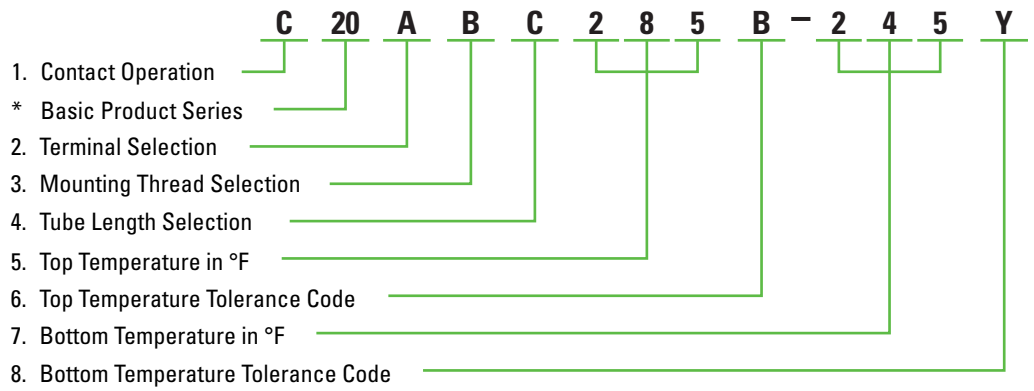

3. MOUNTING THREAD SELECTION

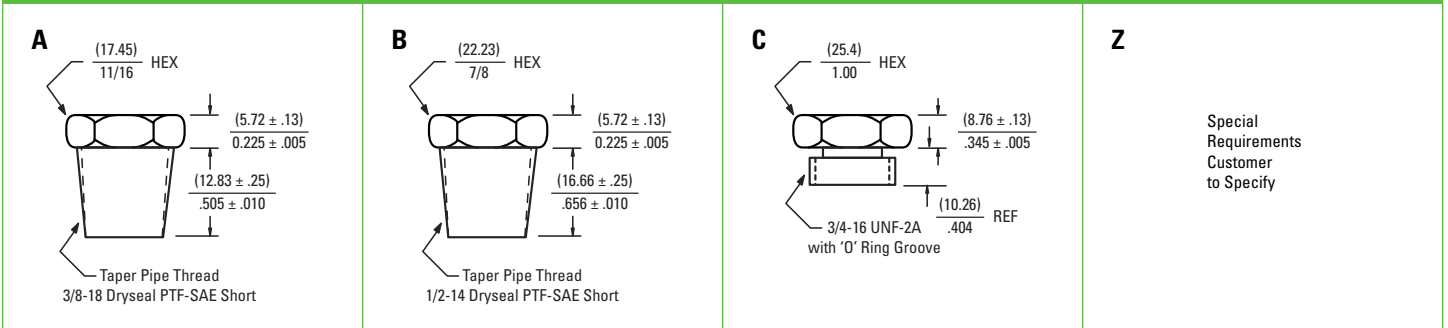

4. TUBE LENGTH SELECTION

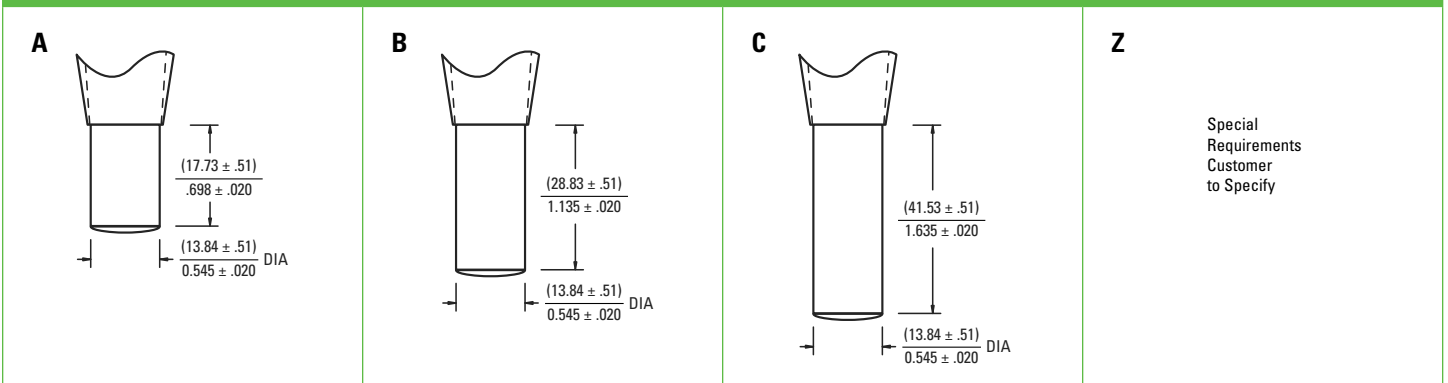

5. TOP TEMPERATURE IN °F

	°F	°C	°F	°C	°F	°C
Temperature Setting	35°F to 250°F	1.7°C to 121.1°C	251°F to 400°F	94°C to 149°C	401°F to 480°F	150°C to 163°C
Standard Tolerance	±5°F	±2.8°C	±10°F	±5.6°C	±25°F	±13.9°C
Nominal Differential	20°F	11.1°C	40°F	22.2°C	40°F	22.2°C

NOTES:

- Select any temperature in the range of 140°F to 480°F. Standard choices fall on the 5°F increments, for example 140°F, 145°F, 150°F, 155°F... up to 475°F or 480°F
- Specify the °F temperature in the part numbering scheme as a three digit code without the °F in the part number. For example, for 200°F, put in code '200'

6. TOP TEMPERATURE TOLERANCE

CODE	A	C	N	X	Z
± °F	±5°F	±10°F	±25°F	Maximum	Customer to Specify
± °C	±2.8°C	±5.6°C	±13.9°C	Maximum	Customer to Specify

NOTES:

- The standard tolerance for the top temperature is based on the temperature range the top temperature falls in, please refer to "5. Top Temperature in °F" chart, and select the appropriate code for a standard top temperature tolerance.

7. BOTTOM TEMPERATURE IN °F

"Bottom Temperature in °F" equals the "Top Temperature in °F" minus the "Nominal Differential in °F for that temperature".

Example 1: 150°F – 25°F = 125°F

Example 2: 300°F – 35°F = 265°F

Example 3: 405°F – 40°F = 365°F

NOTES:

- Specify the °F temperature in the part numbering scheme as a three digit code without the °F in the part number (example 350°F, put in the code as '350')

8. BOTTOM TEMPERATURE TOLERANCE

CODE	A	C	N	Y	Z
± °F	±5°F	±10°F	±25°F	Minimum	Customer to Specify
± °C	±2.8°C	±5.6°C	±13.9°C	Minimum	Customer to Specify

NOTES:

- The typical standard bottom temperature tolerance is a 'Y' = minimum trip, which indicates the "reset" trip occurs at or above the lower temperature set point.
- The other standard tolerances are based on the temperature range the bottom temperature is in. The most convenient solution is to use either the 'Y' minimum reset code or choose the same tolerance code selection used in "6. Top Temperature Tolerance Code".



SENSATA TECHNOLOGIES

529 Pleasant Street
 Attleboro, MA 02703-0964 USA
 1-508-236-3287 (Main)
 1-508-236-1598 (Fax)
<http://airpax.sensata.com>
<http://www.sensata.com>

Important Notice: Sensata Technologies (Sensata) reserves the right to make changes to or discontinue any product or service identified in this publication without notice. Sensata advises its customers to obtain the latest version of the relevant information to verify, before placing any orders, that the information being relied upon is current. Sensata assumes no responsibility for infringement of patents or rights of others based on Sensata applications assistance or product specifications since Sensata does not possess full access concerning the use or application of customers' products. Sensata also assumes no responsibility for customers' product designs.