

CUR 3105

Hall-Effect Current Transducer

Copyright, Warranty, and Limitation of Liability

The information and data contained in this document are believed to be accurate and reliable. The software and proprietary information contained therein may be protected by copyright, patent, trademark and/or other intellectual property rights of Micronas. All rights not expressly granted remain reserved by Micronas.

Micronas assumes no liability for errors and gives no warranty representation or guarantee regarding the suitability of its products for any particular purpose due to these specifications.

By this publication, Micronas does not assume responsibility for patent infringements or other rights of third parties which may result from its use. Commercial conditions, product availability and delivery are exclusively subject to the respective order confirmation.

Any information and data which may be provided in the document can and do vary in different applications, and actual performance may vary over time.

All operating parameters must be validated for each customer application by customers' technical experts. Any new issue of this document invalidates previous issues. Micronas reserves the right to review this document and to make changes to the document's content at any time without obligation to notify any person or entity of such revision or changes. For further advice please contact us directly.

Do not use our products in life-supporting systems, aviation and aerospace applications! Unless explicitly agreed to otherwise in writing between the parties, Micronas' products are not designed, intended or authorized for use as components in systems intended for surgical implants into the body, or other applications intended to support or sustain life, or for any other application in which the failure of the product could create a situation where personal injury or death could occur.

No part of this publication may be reproduced, photocopied, stored on a retrieval system or transmitted without the express written consent of Micronas.

Micronas Patents

Choppered Offset Compensation protected by Micronas patents no. US5260614A, US5406202A, EP0525235B1 and EP0548391B1.

Sensor programming with VDD-Modulation protected by Micronas Patent No. EP 0 953 848.

Third-Party Trademarks

All brand and product names or company names may be trademarks of their respective companies.

Contents

Page	Section	Title
4	1.	Introduction
4	1.1.	Features
5	1.2.	Marking Code
5	1.3.	Operating Junction Temperature Range (T_J)
5	1.4.	IC Package Codes
5	1.5.	Solderability and Welding
5	1.6.	Pin Connections and Short Descriptions
5	1.6.1.	TO92UT Package
6	1.6.2.	SOIC8 Package
7	2.	Functional Description
7	2.1.	General Function
9	2.2.	Digital Signal Processing and EEPROM
12	2.3.	Calibration Procedure
12	2.3.1.	General Procedure
14	3.	Specifications
14	3.1.	Outline Dimensions
19	3.2.	Dimensions of Sensitive Area
19	3.3.	Positions of Sensitive Areas
19	3.4.	Absolute Maximum Ratings
20	3.4.1.	Storage and Shelf Life for TO92UT Package
20	3.4.2.	Storage and Shelf Life for SOIC8 Package
20	3.5.	Recommended Operating Conditions
21	3.6.	Characteristics
22	3.6.1.	Definition of Sensitivity Error ES
23	3.7.	Open-Circuit Detection
24	3.8.	Power-On Operation
24	3.9.	Overvoltage and Undervoltage Detection
24	3.10.	Magnetic Characteristics
25	4.	Application Notes
25	4.1.	Application Circuit
25	4.2.	Use of two CUR3105 in Parallel
25	4.3.	Ambient Temperature
25	4.4.	EMC and ESD
26	5.	Programming of the Current Transducer
26	5.1.	Definition of Programming Pulses
26	5.2.	Definition of the Telegram
28	5.3.	Telegram Codes
29	5.4.	Number Formats
29	5.5.	Register Information
32	5.5.1.	Programming Information
33	6.	Data Sheet History

Hall-Effect Current Transducer

Release Note: Revision bars indicate significant changes to the previous edition.

1. Introduction

The CUR 3105 is a new current transducer based on the Hall effect. The IC can be used for very precise current measurements. The measured current is proportional to the analog output voltage driven by the sensor's output. Major characteristics like magnetic field range, sensitivity, output quiescent voltage (output voltage at $B = 0$ mT), and output voltage range are programmable in a non-volatile memory. The transducer has a ratiometric output characteristic, which means that the output voltage is proportional to the current and the supply voltage. It is possible to program different transducers which are in parallel to the same supply voltage individually.

The CUR 3105 features a temperature-compensated Hall plate with choppered offset compensation, an A/D converter, digital signal processing, a D/A converter with output driver, an EEPROM memory with redundancy and lock function for the calibration data, an EEPROM for customer serial number, a serial interface for programming the EEPROM, and protection devices at all pins. The internal digital signal processing is of great benefit because analog offsets, temperature shifts, and mechanical stress do not degrade the transducers accuracy.

The CUR 3105 is programmable by modulating the supply voltage. No additional programming pin is needed. The easy programmability allows a 2-point calibration by adjusting the output voltage directly to the input signal (current). Individual adjustment of each transducer during the customer's manufacturing process is possible. With this calibration procedure, the tolerances of the IC and the mechanical positioning can be compensated in the final assembly. This offers a low-cost alternative for all applications that presently need mechanical adjustment or laser trimming for calibrating the system.

The calculation of the individual IC characteristics and the programming of the EEPROM memory can easily be done with a PC and the application kit from Micronas.

The transducer is designed for industrial, white goods and automotive applications and operates with typically 5 V supply voltage in the wide junction temperature range from -40 °C up to 170 °C. The CUR 3105 is available in the very small leaded packages TO92UT-1 and TO92UT-2, as well as in the small eight-pin SOIC8 SMD package.

1.1. Features

- high-precision current transducer with ratiometric output and digital signal processing
- low output voltage drifts over temperature
- 12-bit analog output
- multiple programmable magnetic characteristics in a non-volatile memory (EEPROM) with redundancy and lock function
- open-circuit (ground and supply line break detection) with $5\text{ k}\Omega$ pull-up and pull-down resistor, overvoltage and undervoltage detection
- for programming an individual transducer within several ICs in parallel to the same supply voltage, a selection can be done via the output pin
- programmable clamping function
- programming through modulation of the supply voltage
- operates from -40 °C up to 170 °C junction temperature
- operates from 4.5 V up to 5.5 V supply voltage in specification and functions up to 8.5 V
- operates with static magnetic fields and dynamic magnetic fields up to 1 kHz
- overvoltage and reverse-voltage protection at all pins
- magnetic characteristics extremely robust against mechanical stress
- short-circuit protected push-pull output
- EMC and ESD optimized design

1.2. Marking Code

The CUR 3105 has a marking on the package surface (branded side). This marking includes the name of the IC and the temperature range.

Type	Temperature Range			
	A	K	I	C
CUR 3105	3105A	3105K	3105I	3105C

1.3. Operating Junction Temperature Range (T_J)

The ICs from Micronas are specified to the chip temperature (junction temperature T_J).

A: T_J = -40 °C to +170 °C

K: T_J = -40 °C to +140 °C

I: T_J = -20 °C to +125 °C

C: T_J = 0 °C to +85 °C

The relationship between ambient temperature (T_A) and junction temperature is explained in Section 4.3. on page 25.

1.4. IC Package Codes

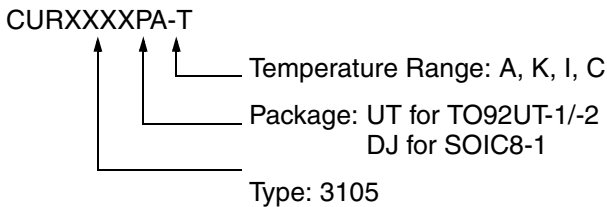

Example: **CUR3105DJ-K**

- Type: 3105
- Package: SOIC8-1
- Temperature Range: T_J = -40 °C to +140 °C

The ICs are available in a wide variety of packaging versions and quantities. For more detailed information, please refer to the brochure: "Hall Sensors: Ordering Codes, Packaging, Handling".

1.5. Solderability and Welding

Soldering

During soldering reflow processing and manual reworking, a component body temperature of 260 °C should not be exceeded.

Welding (for TO92UT package only)

Device terminals should be compatible with laser and resistance welding. Please note that the success of the welding process is subject to different welding parameters which will vary according to the welding technique used. A very close control of the welding parameters is absolutely necessary in order to reach satisfying results. Micronas, therefore, does not give any implied or express warranty as to the ability to weld the component.

1.6. Pin Connections and Short Descriptions

1.6.1. TO92UT Package

Pin No.	Pin Name	Type	Short Description
1	V _{DD}	IN	Supply Voltage and Programming Pin
2	GND		Ground
3	OUT	OUT	Push Pull Output and Selection Pin

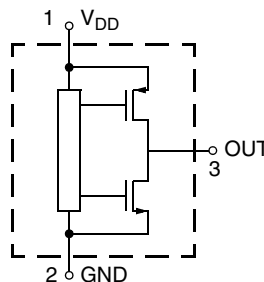

Fig. 1-1: Pin configuration TO92UT

1.6.2. SOIC8 Package

Pin No.	Pin Name	Type	Short Description
1	V _{DD}	IN	Supply Voltage and Programming Pin
2,5,6,7,8	GND		Ground
3	NC		Not Connected
4	OUT	OUT	Push-Pull Output and Selection Pin

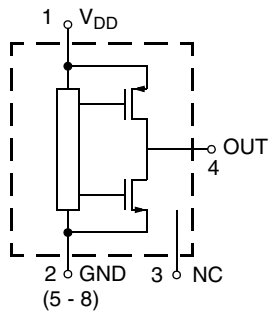

Fig. 1–2: Pin configuration SOIC8

Note: Note: Pins number 2, 5, 6, 7, and 8 must be connected to GND.

2. Functional Description

2.1. General Function

The CUR3105 is a monolithic integrated circuit which provides an output voltage proportional to the magnetic flux through the Hall plate and proportional to the supply voltage (ratiometric behavior).

The external magnetic field component perpendicular to the branded side of the package generates a Hall voltage proportional to the magnetic field. This voltage is converted to a digital value, processed in the Digital Signal Processing Unit (DSP) according to the settings of the EEPROM registers, converted to an analog voltage with ratiometric behavior, and stabilized by a push-pull output transistor stage. The function and the parameters for the DSP are explained in Section 2.2. on page 9.

The setting of the LOCK register disables the programming of the EEPROM memory for all time. This register cannot be reset.

As long as the LOCK register is not set, the output characteristic can be adjusted by programming the EEPROM registers. The IC is addressed by modulating the supply voltage (see Fig. 2-1). In the supply voltage range from 4.5 V up to 5.5 V, the transducer generates an analog output voltage. After detecting a command, the transducer reads or writes the memory

and answers with a digital signal on the output pin. The analog output is switched off during the communication. Several ICs in parallel to the same supply and ground line can be programmed individually. The selection of each IC is done via its output pin.

The open-circuit detection provides a defined output voltage if the V_{DD} or GND line is broken. Internal temperature compensation circuitry and the chopped offset compensation enables operation over the full temperature range with minimal changes in accuracy and high offset stability. The circuitry also rejects offset shifts due to mechanical stress from the package. The non-volatile memory consists of redundant and non-redundant EEPROM cells. The non-redundant EEPROM cells are only used to store production information inside the IC. In addition, the IC is equipped with devices for overvoltage and reverse-voltage protection at all pins.

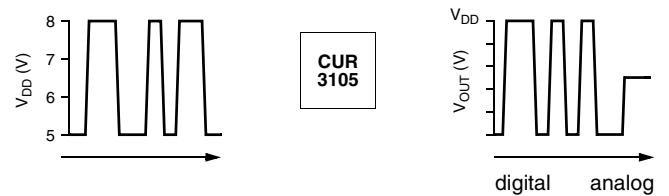

Fig. 2-1: Programming with V_{DD} modulation

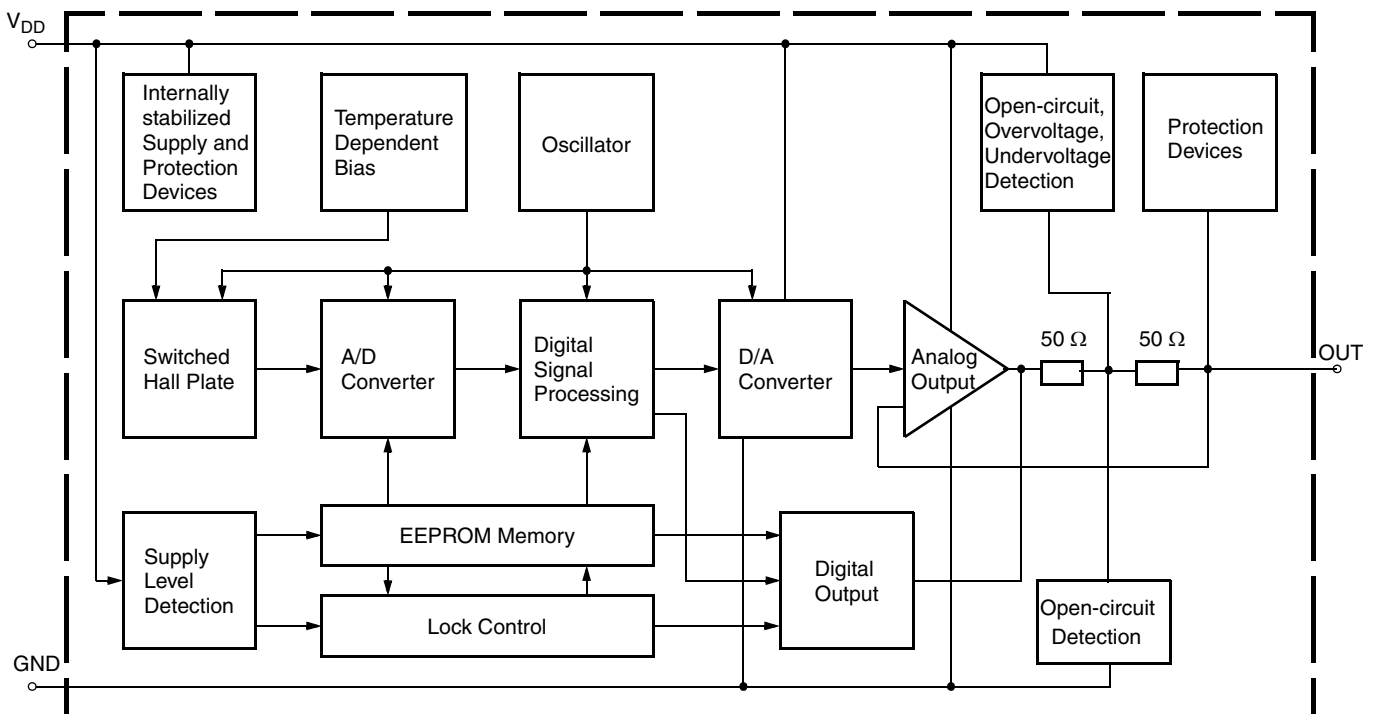

Fig. 2-2: CUR3105 block diagram

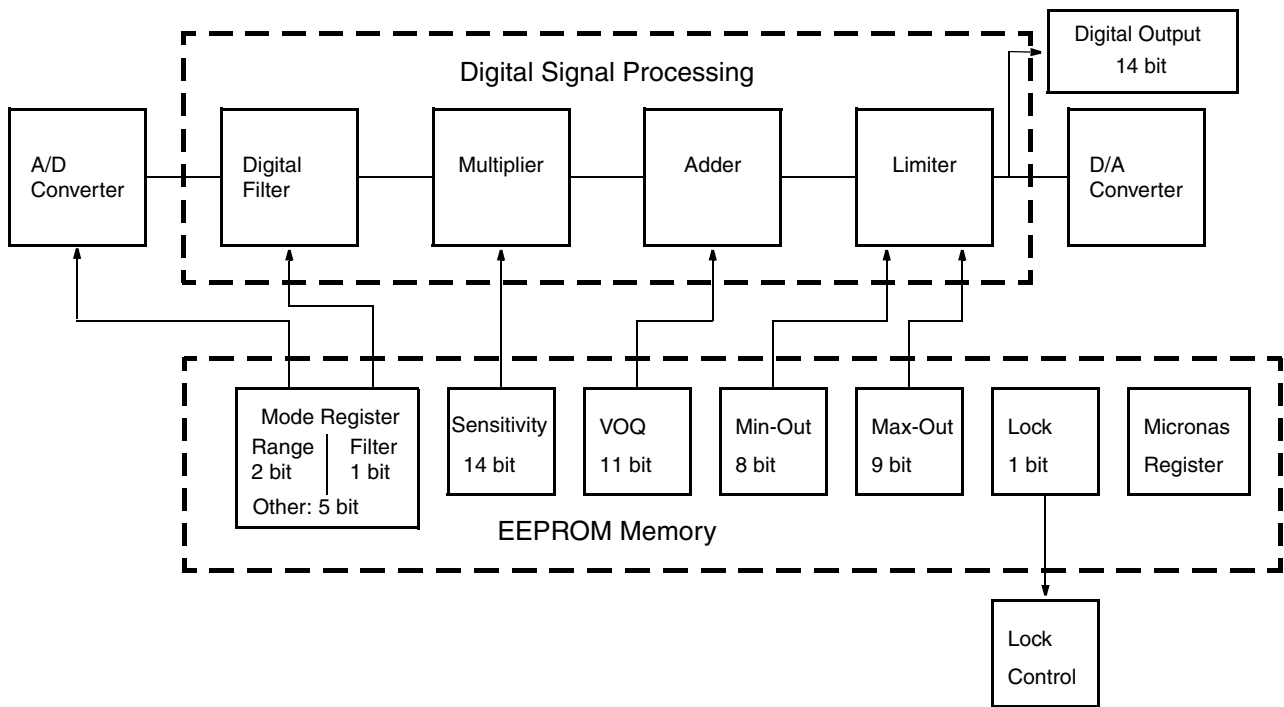

Fig. 2-3: Details of EEPROM and digital signal processing

2.2. Digital Signal Processing and EEPROM

The DSP is the main part of this transducer and performs the signal conditioning. The parameters for the DSP are stored in the EEPROM registers. The details are shown in Fig. 2–3.

Terminology:

SENSITIVITY: name of the register or register value

Sensitivity: name of the parameter

The EEPROM registers consist of four groups:

Group 1 contains the registers for the adaption of the transducer to the magnetic field generated by the current to be measured: MODE for selecting the magnetic field range and filter frequency to select the bandwidth of the transducer.

Group 2 contains the registers for defining the output characteristics: SENSITIVITY, VOQ, CLAMP-LOW, and CLAMP-HIGH. The output characteristic of the transducer is defined by these 4 parameters.

- The parameter VOQ (Output Quiescent Voltage) corresponds to the output voltage at B = 0 mT.
- The parameter Sensitivity defines the magnetic sensitivity:

$$Sensitivity = \frac{\Delta V_{OUT}}{\Delta B}$$

- The output voltage can be calculated as:

$$V_{OUT} \sim Sensitivity \times B + V_{OQ}$$

The output voltage range can be clamped by setting the registers CLAMP-LOW and CLAMP-HIGH in order to enable failure detection (such as short-circuits to VDD or GND and open connections).

Group 3 contains the general purpose register GP. The GP Register can be used to store customer information, like a serial number after manufacturing. Micronas will use this GP REGISTER to store informations like, Lot number, wafer number, x and y position of the die on the wafer, etc. This information can be readout by the customer and stored in it's on data base or it can stay in the IC as is.

Group 4 contains the Micronas registers and LOCK for the locking of all registers. The Micronas registers are programmed and locked during production. These registers are used for oscillator frequency trimming, A/D

converter offset compensation, and several other special settings.

An external magnetic field generates a Hall voltage on the Hall plate. The ADC converts the amplified positive or negative Hall voltage to a digital value. The digital signal is filtered in the internal low-pass filter and manipulated according to the settings stored in the EEPROM. The digital value after signal processing is readable in the D/A-READOUT register. Depending on the programmable magnetic range of the transducer IC, the operating range of the A/D converter is from –30 mT...+30 mT up to –100 mT...+100 mT.

During further processing, the digital signal is multiplied with the sensitivity factor, added to the quiescent output voltage and limited according to the clamping voltage. The result is converted to an analog signal and stabilized by a push-pull output transistor stage.

The D/A-READOUT at any given magnetic field depends on the programmed magnetic field range, the low-pass filter, TC values and CLAMP-LOW and CLAMP-HIGH. The D/A-READOUT range is min. 0 and max. 16383.

Note: During application design, it should be taken into consideration that the maximum and minimum D/A-READOUT should not saturate in the operational range of the specific application.

Range

The RANGE bits are bit 2 and 3 of the MODE register; they define the magnetic field range of the A/D converter.

Magnetic Field Range	RANGE
–30mT...30 mT	0
–60 mT...60 mT	1
–80 mT...80 mT	2
–100 mT...100 mT	3

Filter

The FILTER bit is bit number 4 of the MODE register; it defines the -3 dB frequency of the digital low pass filter.

-3 dB Frequency	FILTER
500 Hz	0
1 kHz	1

Bit Time

The BITTIME bit is bit number 5 of the MODE register; It defines the protocol bit time for the communication between the IC and the programmer board.

Bit Time	BITTIME
1:64 (Typ. 1.75 ms)	0
1:128 (Typ. 3.5 ms)	1

Output Format

The OUTPUTMODE bits are the bits number 6 to 7 of the MODE register; They define the different output modes.

Output Format	OUTPUTMODE
Analog Output (12 bit)	0
Internal Burn-In Mode	2
Multiplex Analog Output (external trigger)	-

In Analog Output mode, the transducer provides an ratiometric 12-bit analog output voltage between 0 V and 5 V.

In Multiplex Analog Output mode, the IC transmits the LSN and MSN of the output value separately. This enables the IC to transmit a 14-bit signal. In external trigger mode the ECU can switch the output of the IC between LSN and MSN by changing current flow direction through IC output. In case the output is pulled up by a 10 kΩ resistor the IC sends the MSN. If the output is pulled down the IC will send the LSN. Maximum refresh rate is about 500 Hz (2 ms). Three pins are sufficient.

Note: Please contact Micronas for further information about Multiplex Analog Output Mode.

In Burn-In Mode, the signal path of the transducer DSP is stimulated internally without applied magnetic field. In this mode, the transducer provides a “saw tooth” shape output signal. Shape and frequency of the saw tooth signal depends on the programming of the transducer. This mode can be used for Burn-In test in the customers production line.

Sensitivity

The SENSITIVITY register contains the parameter for the multiplier in the DSP. The Sensitivity is programmable between -4 and 4. For V_{DD} = 5 V, the register can be changed in steps of 0.00049.

For all calculations, the digital value from the magnetic field of the D/A converter is used. This digital information is readable from the D/A-READOUT register.

$$SENSITIVITY = \frac{\Delta V_{out} \times 16383}{2 \cdot \Delta DA-Readout \cdot V_{DD}}$$

VOQ

The VOQ register contains the parameter for the adder in the DSP. V_{OQ} is the output voltage without external magnetic field (B = 0 mT) and programmable from -V_{DD} up to V_{DD}. For V_{DD} = 5 V, the register can be changed in steps of 4.9 mV.

Note: If V_{OQ} is programmed to a negative voltage, the maximum output voltage is limited to:

$$V_{OUTmax} = V_{OQ} + V_{DD}$$

Clamping Voltage

The output voltage range can be clamped in order to detect failures like shorts to V_{DD} or GND or an open circuit.

The CLAMP-LOW register contains the parameter for the lower limit. The lower clamping voltage is programmable between 0 V and $V_{DD}/2$. For $V_{DD} = 5$ V, the register can be changed in steps of 9.77 mV.

The CLAMP-HIGH register contains the parameter for the upper limit. The upper clamping voltage is programmable between 0 V and V_{DD} . For $V_{DD} = 5$ V, in steps of 9.77 mV.

GP Register

This register can be used to store some information, like production date or customer serial number. Micronas will store production Lot number, wafer number and x,y coordinates in three blocks of this registers. The total register contains of four blocks with a length of 13 bit each. The customer can read out this information and store it in his own production data base for reference or he can change them and store own production information.

Note: To enable programming of the GP register bit 0 of the MODE register has to be set to 1. This register is not a guarantee for trace-ability.

LOCKR

By setting the first bit of this 2-bit register, all registers will be locked, and the IC will no longer respond to any supply voltage modulation. This bit is active after the first power-off and power-on sequence after setting the LOCK bit.

Warning: This register cannot be reset!

D/A-READOUT

This 14-bit register delivers the actual digital value of the applied magnetic field after the signal processing. This register can be read out and is the basis for the calibration procedure of the IC in the system environment.

Note: The MSB and LSB are reversed compared with all the other registers. Please reverse this register after readout.

2.3. Calibration Procedure

2.3.1. General Procedure

For calibration in the system environment, the application kit from Micronas is recommended. It contains the hardware for the generation of the serial telegram for programming (Programmer Board Version 5.1) and the corresponding software (PC3105) for the input of the register values.

For the individual calibration of each transducer in the customer application, a two point adjustment is recommended. The calibration shall be done as follows:

Step 1: Input of the registers which need not be adjusted individually

The magnetic range (depending on the maximum field strength generated by the current), the filter frequency, the output mode and the GP Register value are given for this application. Therefore, the values of the following registers should be identical for all transducers of the customer application.

- FILTER
(according to the maximum signal frequency)
- RANGE
(according to the maximum magnetic field at the IC position)
- OUTPUTMODE
- GP
(if the customer wants to store own production information. It is not necessary to change this register)

As the clamping voltages are given. They have an influence on the D/A-Readout value and have to be set therefore after the adjustment process.

Write the appropriate settings into the CUR3105 registers.

Step 2: Initialize DSP

As the D/A-READOUT register value depends on the settings of SENSITIVITY, VOQ and CLAMP-LOW/HIGH, these registers have to be initialized with defined values, first:

- $VOQ_{INITIAL} = 2.5 \text{ V}$
- $Sensitivity_{INITIAL} = 0.5$
- Clamp-Low = 0 V
- Clamp-High = 4.999 V

Note: For inverted output characteristics it is necessary to change $Sensitivity_{INITIAL}$ to -0.5. Please contact your application support team for further details.

Step 3: Define Calibration Points

The calibration points 1 and 2 can be set inside the specified range. The corresponding values for V_{OUT1} and V_{OUT2} result from the application requirements.

$$Lowclampingvoltage \leq V_{OUT1,2} \leq Highclampingvoltage$$

For highest accuracy of the transducer, calibration points near the minimum and maximum input signal are recommended. The difference of the output voltage between calibration point 1 and calibration point 2 should be more than 3.5 V.

Step 4: Calculation of V_{OQ} and Sensitivity

Set the system to calibration point 1 and read the register D/A-READOUT. The result is the value D/A-READOUT1.

Now, set the system to calibration point 2, read the register D/A-READOUT again, and get the value D/A-READOUT2.

With these values and the target values V_{OUT1} and V_{OUT2} , for the calibration points 1 and 2, respectively, the values for Sensitivity and V_{OQ} are calculated as:

$$Sensitivity = \frac{1}{2} \times \frac{(V_{out2} - V_{out1})}{(D/A-Readout2 - D/A-Readout1)} \times \frac{16384}{5}$$

$$V_{OQ} = \frac{1}{16} \times \left[\frac{V_{out2} \times 16384}{5} - [(D/A-Readout2 - 8192) \times Sensitivity \times 2] \right] \times \frac{5}{1024}$$

This calculation has to be done individually for each IC.

Next, write the calculated values for Sensitivity and V_{OQ} into the IC for adjusting the transducer. At that time it is also possible to store the application specific values for Clamp-Low and Clamp-High into the ICs EEPROM.

The transducer is now calibrated for the customer application. However, the programming can be changed again and again if necessary.

Note: For a recalibration, the calibration procedure has to be started at the beginning (step 1). A new initialization is necessary, as the initial values from step 1 are overwritten in step 4.

Step 5: Locking the Transducer

The last step is activating the LOCK function by programming the LOCK bit. Please note that the LOCK function becomes effective after power-down and power-up of the Hall IC. The IC is now locked and does not respond to any programming or reading commands.

Warning: This register can not be reset!

3. Specifications

3.1. Outline Dimensions

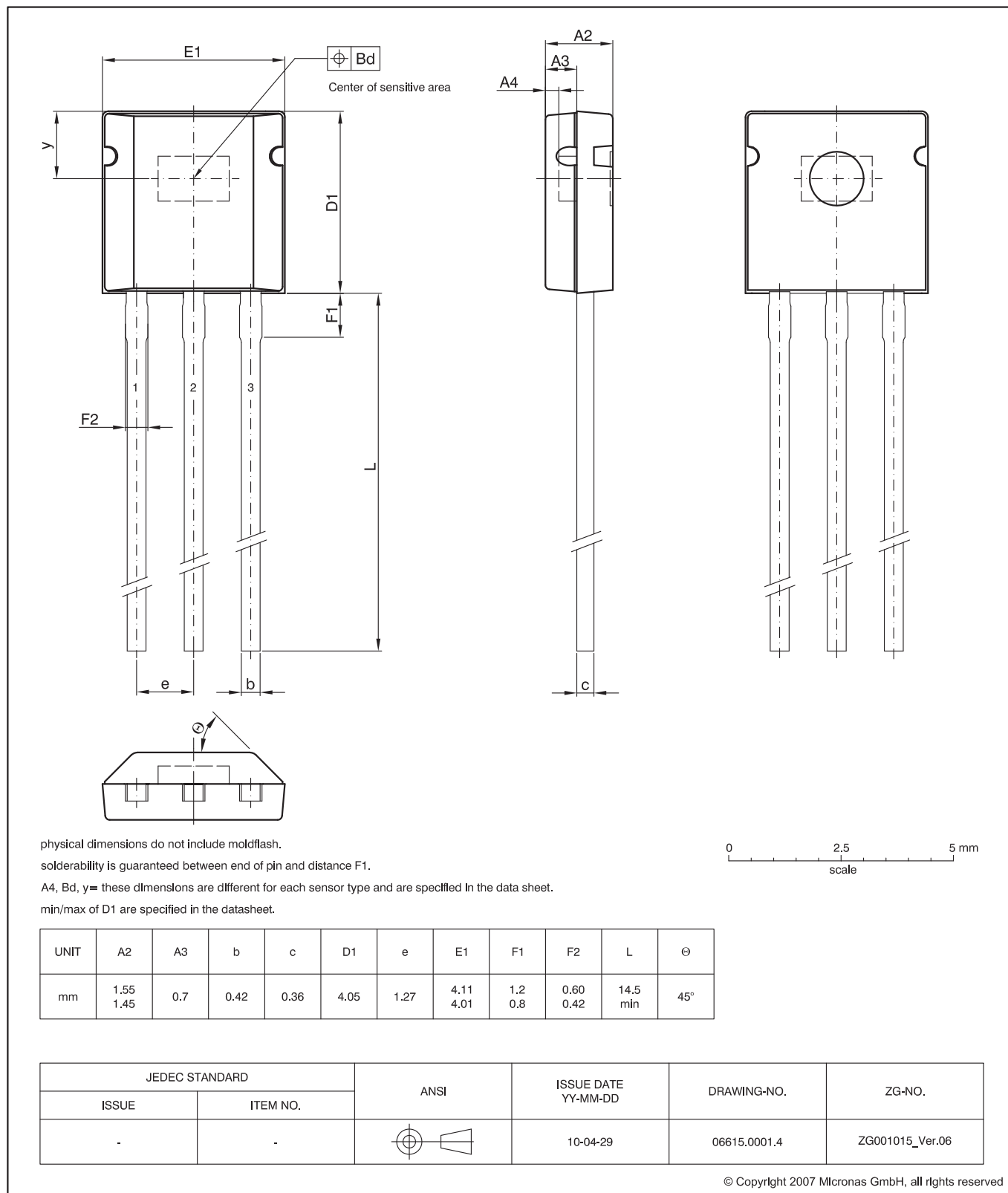

Fig. 3-1:
TO92UT-2 Plastic Transistor Standard UT package, 3 leads
Weight approximately 0.12 g

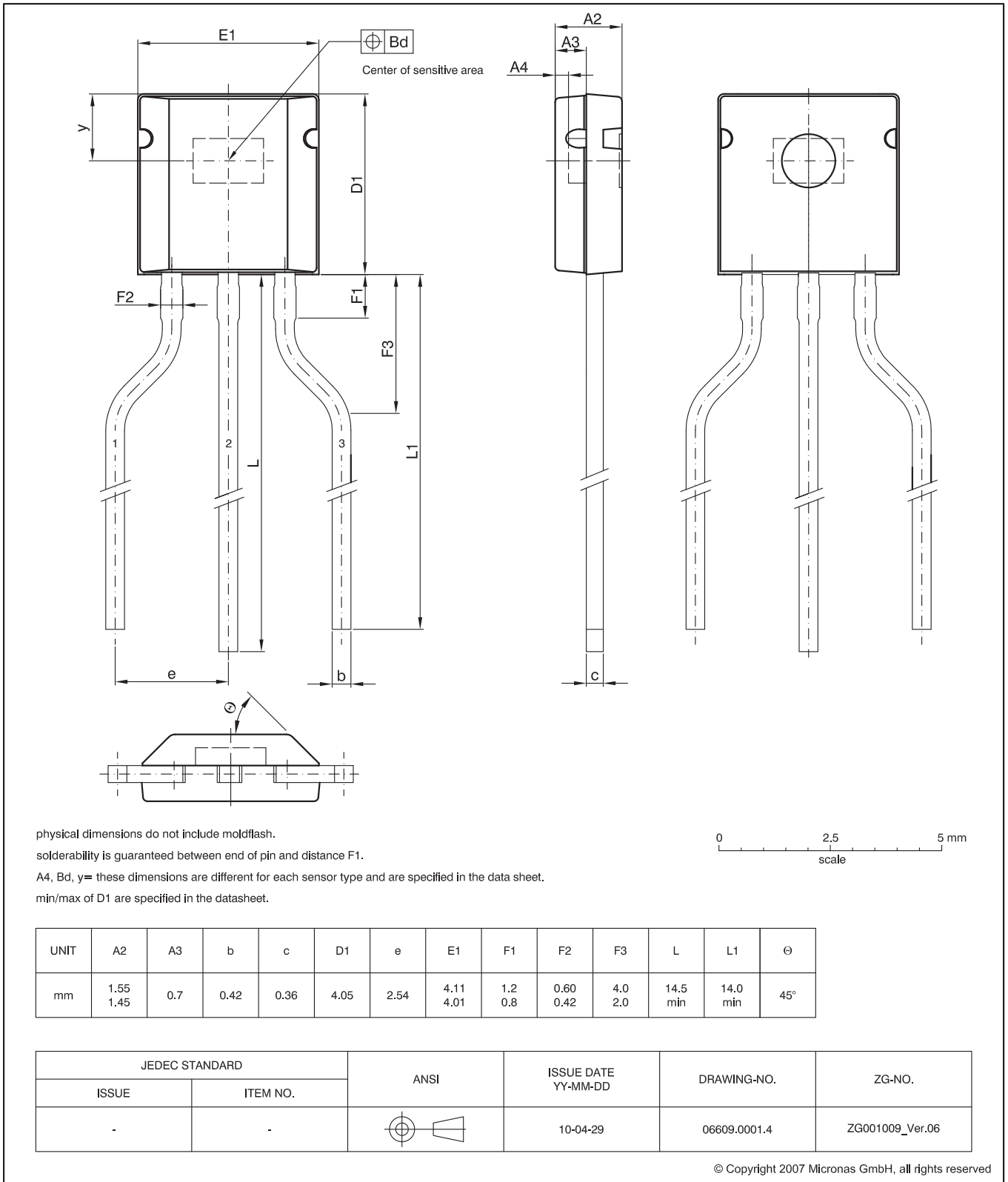
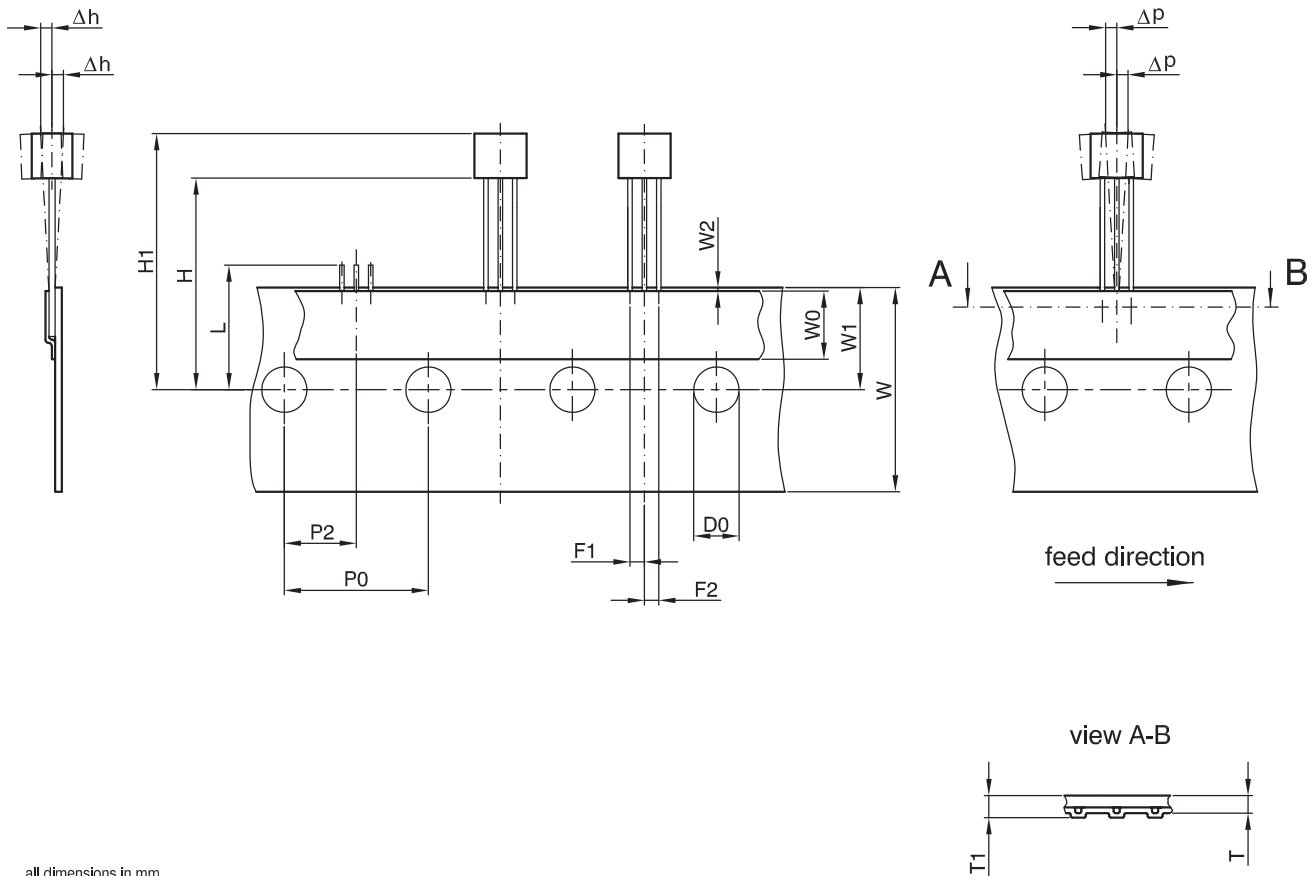

Fig. 3-2:
TO92UT-1 Plastic Transistor Standard UT package, 3 leads, spread
 Weight approximately 0.12 g



all dimensions in mm
 other dimensions see drawing of bulk
 max. allowed tolerance over 20 hole spacings ± 1.0
 H1= this dimension is different for each sensor type and is specified in the data sheet

UNIT	D0	F1	F2	H	Δh	L	P0	P2	Δp	T	T1	W	W0	W1	W2
mm	4.0	1.47 1.07	1.47 1.07	20.0 18.0	± 1.0	11.0 max	13.2 12.2	7.05 5.65	± 1.0	0.5	0.9	18.0	6.0	9.0	0.3

JEDEC STANDARD		ANSI	ISSUE DATE YY-MM-DD	DRAWING-NO.	ZG-NO.
ISSUE	ITEM NO.				
-	ICE 60286-2		07-01-18	06631.0001.4	ZG001031_Ver.03

Fig. 3-3:
T092UA/UT-2: Dimensions ammpack inline, not spread

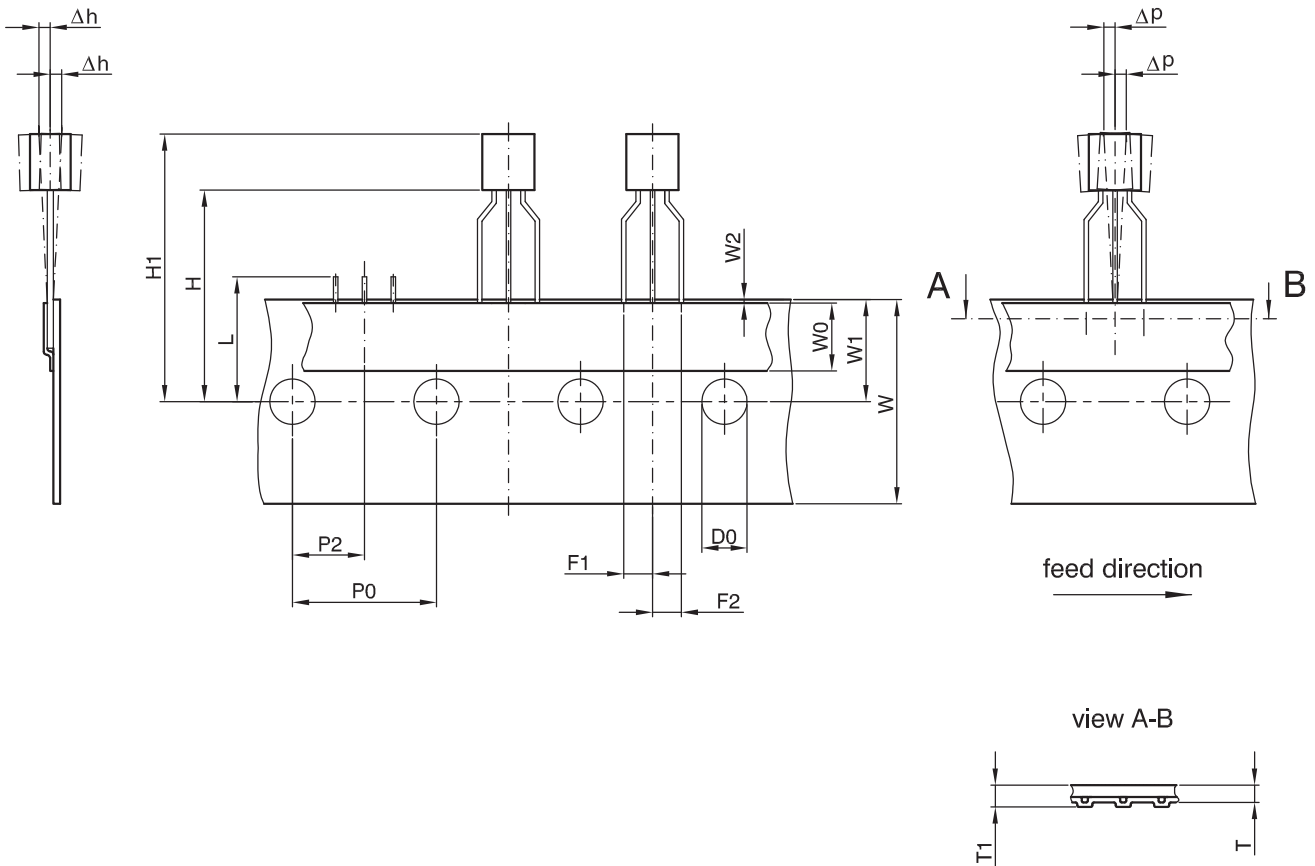

all dimensions in mm
 other dimensions see drawing of bulk
 max. allowed tolerance over 20 hole spacings ± 1.0
 H_1 = this dimension is different for each sensor type and is specified in the data sheet

UNIT	D0	F1	F2	H	Δh	L	P0	P2	Δp	T	T1	W	W0	W1	W2
mm	4.0	2.74 2.34	2.74 2.34	20.0 18.0	± 1.0	11.0 max	13.2 12.2	7.05 5.65	± 1.0	0.5	0.9	18.0	6.0	9.0	0.3

JEDEC STANDARD		ANSI	ISSUE DATE YY-MM-DD	DRAWING-NO.	ZG-NO.
ISSUE	ITEM NO.				
-	ICE 60286-2		07-01-18	06632.0001.4	ZG001032_Ver.04

Fig. 3-4:
T092UA/UT: Dimensions ammpack inline, spread

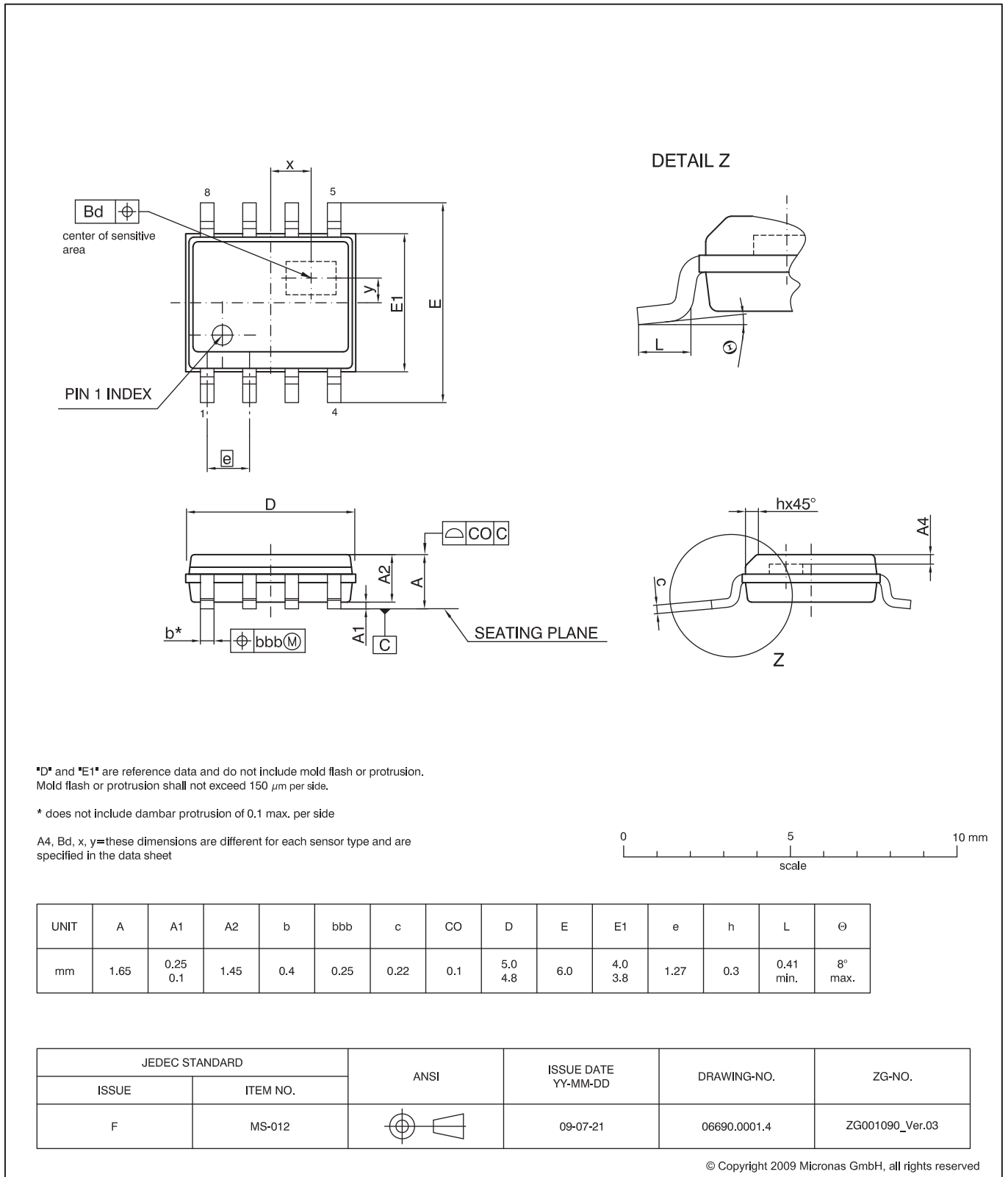

Fig. 3-5:
SOIC8-1: Plastic **S**mall **O**utline **I**C package, 8 leads, gullwing bent, 150 mil
 Ordering code: DJ
 Weight approximately 0.084 g

3.2. Dimensions of Sensitive Area

0.25 mm x 0.25 mm

3.3. Positions of Sensitive Areas

	TO92UT-1/-2	SOIC8-1
x	n.a.	0 mm nominal
y	1.5 mm nominal	0.197 mm nominal
A4	0.3 mm nominal	0.38 mm nominal
Bd	0.3 mm	0.3 mm
D1	4.05 ±0.05 mm	n.a.
H1	min. 22.0 mm, max. 24.1 mm	n.a.

3.4. Absolute Maximum Ratings

Stresses beyond those listed in the “Absolute Maximum Ratings” may cause permanent damage to the device. This is a stress rating only. Functional operation of the device at these conditions is not implied. Exposure to absolute maximum rating conditions for extended periods will affect device reliability.

This device contains circuitry to protect the inputs and outputs against damage due to high static voltages or electric fields; however, it is advised that normal precautions be taken to avoid application of any voltage higher than absolute maximum-rated voltages to this circuit.

All voltages listed are referenced to ground (GND).

Symbol	Parameter	Pin No.	Min.	Max.	Unit	Condition
V _{DD}	Supply Voltage	1	-8.5	8.5	V	t < 96 h not additive
V _{DD}	Supply Voltage	1	-16	16	V	¹⁾ not additive t < 1 h
-I _{DD}	Reverse Supply Current	1	-	50 ¹⁾	mA	
V _{OUT}	Output Voltage	3 or 4	-5 ³⁾ -5 ³⁾	8.5 ²⁾ 16 ¹⁾	V	not additive t < 1 h, not additive
V _{OUT} - V _{DD}	Excess of Output Voltage over Supply Voltage	3 or 4 , 1	-	2	V	
I _{OUT}	Continuous Output Current	3 or 4	-10	10	mA	
t _{Sh}	Output Short Circuit Duration	3 or 4	-	10	min	
¹⁾ as long as T _{Jmax} is not exceeded ²⁾ as long as T _{Jmax} is not exceeded, output is not protected to external -16 V) ⁵⁾ internal protection resistor = 50 Ω						

3.4.1. Storage and Shelf Life for TO92UT Package

The permissible storage time (shelf life) of the sensors is unlimited, provided the sensors are stored at a maximum of 30 °C and a maximum of 85% relative humidity. At these conditions, no Dry Pack is required.

Solderability is guaranteed for one year from the date code on the package.

3.4.2. Storage and Shelf Life for SOIC8 Package

The SOIC8 package is a moisture-sensitive Surface Mount Device. The Moisture Sensitivity Level (MSL) is defined according to JEDEC J-STD-020 (Moisture/Reflow Sensitivity Classification for Nonhermetic Solid State Surface Mount Devices). The device is packed acc. to IPC/JEDEC J-STD-033: Handling, Packing, Shipping and Use of Moisture/Reflow Sensitive Surface Mount Devices. By using these procedures, safe and damage-free reflow can be achieved.

Please follow the instructions printed on each Moisture Barrier Bag. These instructions contain information about the Moisture Sensitivity Level “MSL”, the maximum reflow temperature “Peak Package Body Temp.”

and the time frame “Time for Mounting after opening the MBB”. The dry-bag shelf life capability of sealed dry-bags is minimum 12 months starting from the “Bag seal date” printed on each bag.

If moisture-sensitive components have been exposed to ambient air for longer than the specified time according to their MSL, or the humidity indicator card indicates too much moisture after opening a Moisture Barrier Bag (MBB), the components have to be baked prior to the assembly process. Please refer to IPC/JEDEC J-STD-033 for details. Please be aware that packing materials may not withstand higher baking temperatures.

3.5. Recommended Operating Conditions

Functional operation of the device beyond those indicated in the “Recommended Operating Conditions/Characteristics” is not implied and may result in unpredictable behavior, reduce reliability and lifetime of the device.

All voltages listed are referenced to ground (GND).

Symbol	Parameter	Pin No.	Min.	Typ.	Max.	Unit	Remarks
V _{DD}	Supply Voltage	1	4.5	5	5.5	V	
I _{OUT}	Continuous Output Current	3 or 4	-1.2	-	1.2	mA	
R _L	Load Resistor	3 or 4	5.0	10	-	kΩ	Can be pull-up or pull-down resistor
C _L	Load Capacitance	3 or 4	0.33	10	1000	nF	
N _{PRG}	Number of EEPROM Programming Cycles	-	-	-	100	Cycles	0°C < T _{amb} < 55°C
T _J	Junction Operating Temperature ¹⁾	-	-40 -40 -40	- - -	125 150 170	°C	for 8000 h (not additive) for 2000 h (not additive) <1000 h (not additive)
¹⁾ Depends on the temperature profile of the application. Please contact Micronas for life time calculations							

3.6. Characteristics

at $T_J = -40\text{ °C}$ to $+170\text{ °C}$ (for temperature type A), $V_{DD} = 4.5\text{ V}$ to 5.5 V , $GND = 0\text{ V}$ after programming and locking, at Recommended Operation Conditions if not otherwise specified in the column "Conditions".

Typical Characteristics for $T_J = 25\text{ °C}$ and $V_{DD} = 5\text{ V}$.

For all other temperature ranges this table is also valid, but only in the junction temperature range defined by the temperature range (Example: For K-Type this table is limited to $T_J = -40\text{ °C}$ to $+140\text{ °C}$).

Symbol	Parameter	Pin No.	Min.	Typ.	Max.	Unit	Conditions
I_{DD}	Supply Current over Temperature Range	1	–	7	10	mA	
	Resolution	3 or 4	–	12	–	bit	ratiometric to V_{DD} ¹⁾
DNL	Differential Non-Linearity of D/A Converter	3 or 4	–2.0	0	2.0	LSB	Only at 25 °C ambient temperature Production test limit
INL	Non-Linearity of Output Voltage over Temperature	3 or 4	–0.5	0	0.5	%	% of supply voltage ²⁾ For $V_{OUT} = 0.35\text{ V} \dots 4.65\text{ V}$; $V_{DD} = 5\text{ V}$
E_R	Ratiometric Error of Output over Temperature (Error in V_{OUT} / V_{DD})	3 or 4	–0.5	0	0.5	%	$ V_{OUT1} - V_{OUT2} > 2\text{ V}$ during calibration procedure
Voffset	Offset Drift over Temperature Range $ V_{OUT}(B = 0\text{ mT})_{25\text{ °C}} - V_{OUT}(B = 0\text{ mT})_{max} $	3 or 4	0	0.15	0.25	% V_{DD}	$V_{DD} = 5\text{ V}$; 60 mT range, 3 dB frequency = 500 Hz, –0.6 < sensitivity < 0.6
T_K	Temperature Coefficient of Sensitivity	3 or 4	–	0	–	ppm/k	Variation see parameter ES
ES	Error in Magnetic Sensitivity over Temperature Range	3 or 4	–2	0	2	%	$V_{DD} = 5\text{ V}$; 60 mT range, 3 db frequency = 500 Hz (see Section 3.6.1. on page 22)
ΔV_{OUTCL}	Accuracy of Output Voltage at Clamping Low Voltage over Temperature Range	3 or 4	–45	0	45	mV	$R_L = 5\text{ k}\Omega$, $V_{DD} = 5\text{ V}$
ΔV_{OUTCH}	Accuracy of Output Voltage at Clamping High Voltage over Temperature Range	3 or 4	–45	0	45	mV	$R_L = 5\text{ k}\Omega$, $V_{DD} = 5\text{ V}$
V_{OUTH}	Upper Limit of Signal Band ³⁾	3 or 4	4.65	4.8	–	V	$V_{DD} = 5\text{ V}$, $-1\text{ mA} \leq I_{OUT} \leq 1\text{ mA}$
V_{OUTL}	Lower Limit of Signal Band ³⁾	3 or 4	–	0.2	0.35	V	$V_{DD} = 5\text{ V}$, $-1\text{ mA} \leq I_{OUT} \leq 1\text{ mA}$
f_{ADC}	Internal ADC Frequency over Temperature Range	–	–	128	–	kHz	
$t_{r(O)}$	Step Response Time of Output	3 or 4	–	2 1	3 2	ms ms	3 dB Filter frequency = 500 Hz 3 dB Filter frequency = 1 kHz $C_L = 10\text{ nF}$, time from 10% to 90% of final output voltage for a step like signal B_{step} from 0 mT to B_{max}
$t_{d(O)}$	Delay Time of Output	3 or 4	–	0.1	0.5	ms	$C_L = 10\text{ nF}$
t_{POD}	Power-Up Time (Time to Reach Stabilized Output Voltage)	–	1.5	1.7	1.9	ms	$C_L = 10\text{ nF}$, 90% of V_{OUT}
BW	Small Signal Bandwidth (–3 dB)	3 or 4	–	1	–	kHz	$B_{AC} < 10\text{ mT}$; 3 dB Filter frequency = 1 kHz
V_{OUTn}	RMS Noise on Output Voltage	3 or 4	–	6	15	mV	magnetic range = 60 mT 3 dB Filter frequency = 500 Hz Sensitivity ≤ 0.7 ; $C = 4.7\text{ nF}$ (V_{DD} & V_{OUT} to GND)
R_{OUT}	Output Resistance over Recommended Operating Range	3 or 4	–	1	10	Ω	$V_{OUTLmax} \leq V_{OUT} \leq V_{OUTHmin}$
¹⁾ Output DAC full scale = 5 V ratiometric, Output DAC offset = 0 V, Output DAC LSB = $V_{DD}/4096$ ²⁾ if more than 50% of the selected magnetic field range is used and the temperature compensation is suitable ³⁾ Signal Band Area with full accuracy is located between V_{OUTL} and V_{OUTH} . The sensor accuracy is reduced below V_{OUTL} and above V_{OUTH}							

Symbol	Parameter	Pin No.	Min.	Typ.	Max.	Unit	Conditions
TO92UT Packages							
R _{thja}	Thermal Resistance Junction to Air	–	–	–	235	K/W	Measured with a 1s0p board
R _{thjc}	Junction to Case	–	–	–	61	K/W	Measured with a 1s0p board
R _{thjs}	Junction to Solder Point	–	–	–	128	K/W	Measured with a 1s1p board
SOIC8 Package							
R _{thja}	Thermal Resistance Junction to Air	–	–	–	180	K/W	Measured with a 1s0p board
R _{thjc}	Junction to Case	–	–	–	113	K/W	Measured with a 1s1p board
R _{thjc}	Junction to Case	–	–	–	73	K/W	Measured with a 1s0p board
R _{thjc}	Junction to Case	–	–	–	46	K/W	Measured with a 1s1p board

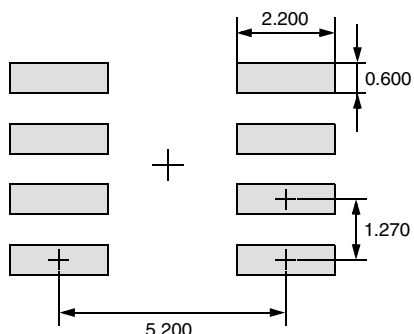

Fig. 3–1: Recommended pad size SOIC8 package

3.6.1. Definition of Sensitivity Error ES

ES is the maximum of the absolute value of 1 minus the quotient of the normalized measured value¹⁾ over the normalized ideal linear²⁾ value:

$$ES = \max \left(\text{abs} \left(\frac{\text{meas}}{\text{ideal}} - 1 \right) \right) \Big|_{[T_{\min}, T_{\max}]}$$

In the below example, the maximum error occurs at -10 °C:

$$ES = \frac{1.001}{0.993} - 1 = 0.8\%$$

1) normalized to achieve a least-square-fit straight-line that has a value of 1 at 25 °C

2) normalized to achieve a value of 1 at 25 °C

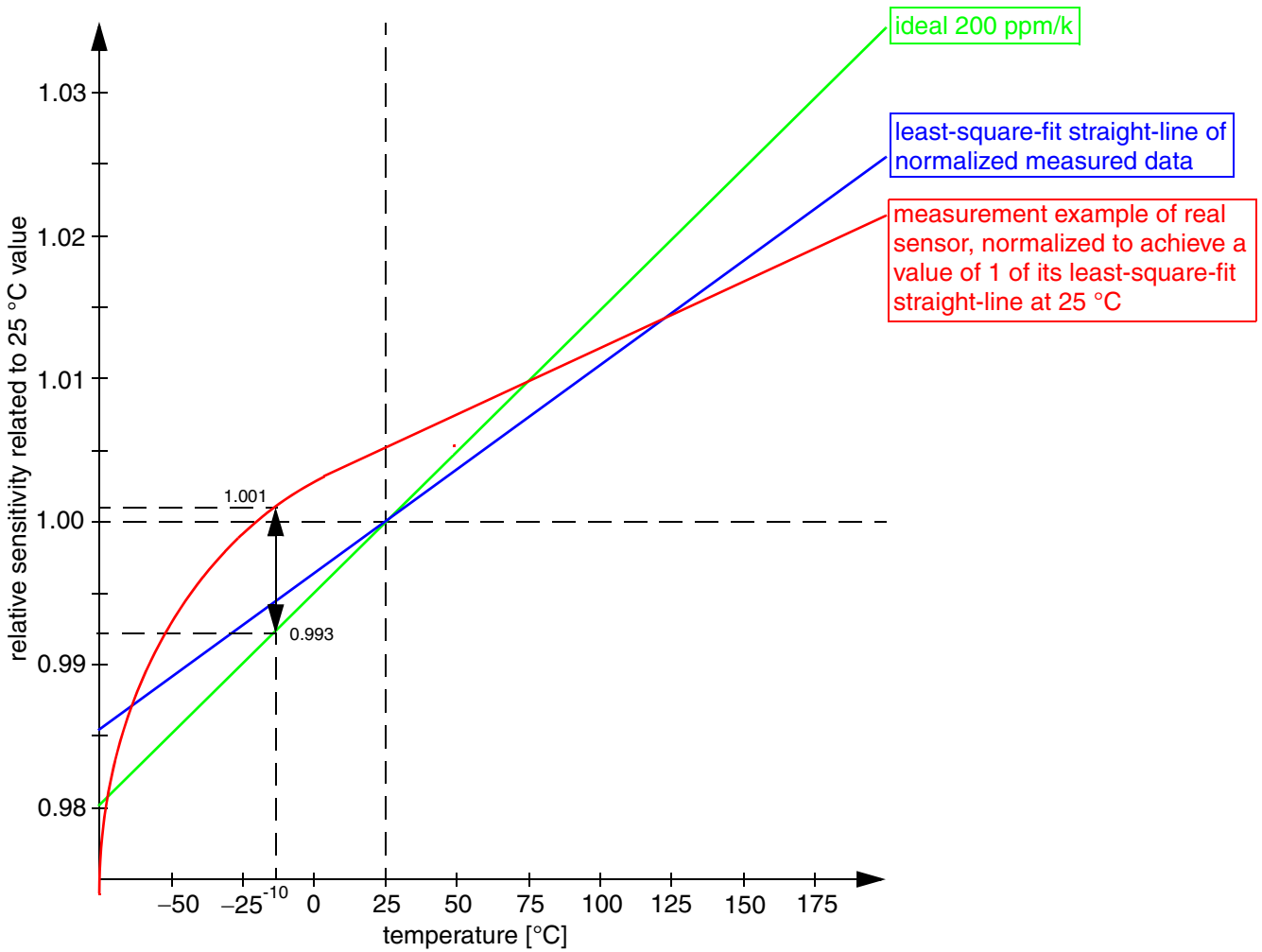

Fig. 3–2: ES definition example

3.7. Open-Circuit Detection

at $T_J = -40\text{ °C}$ to $+170\text{ °C}$ (A-Type), Typical Characteristics for $T_J = 25\text{ °C}$, after locking the sensor. For all other temperature ranges this table is also valid, but only in the junction temperature range defined by the temperature range (Example: For K-Type this table is limited to $T_J = -40\text{ °C}$ to $+140\text{ °C}$).

Symbol	Parameter	Pin No.	Min.	Typ.	Max.	Unit	Comment
V_{OUT}	Output Voltage at Open V_{DD} Line	3 or 4	0	0	0.15	V	$V_{DD} = 5\text{ V}$ $R_L = 10\text{ k}\Omega$ to $200\text{ k}\Omega$
			0	0	0.2	V	$V_{DD} = 5\text{ V}$ $R_L = 5\text{ k}\Omega$ to $10\text{ k}\Omega$
V_{OUT}	Output Voltage at Open GND Line	3 or 4	4.85	4.9	5.0	V	$V_{DD} = 5\text{ V}$ $10\text{ k}\Omega \geq R_L \leq 200\text{ k}\Omega$
			4.8	4.9	5.0	V	$V_{DD} = 5\text{ V}$ $5\text{ k}\Omega \geq R_L < 10\text{ k}\Omega$

R_L : Can be pull-up or pull-down resistor

3.8. Power-On Operation

at $T_J = -40\text{ °C}$ to $+170\text{ °C}$ (A-Type), after programming and locking. Typical Characteristics for $T_J = 25\text{ °C}$
 For all other temperature ranges this table is also valid, but only in the junction temperature range defined by the temperature range (Example: For K-Type this table is limited to $T_J = -40\text{ °C}$ to $+140\text{ °C}$).

Symbol	Parameter	Min.	Typ.	Max.	Unit
POR_{UP}	Power-On Reset Voltage (UP)	-	3.4	-	V
POR_{DOWN}	Power-On Reset Voltage (DOWN)	-	3.0	-	V

3.9. Overvoltage and Undervoltage Detection

at $T_J = -40\text{ °C}$ to $+170\text{ °C}$ (A-Type), Typical Characteristics for $T_J = 25\text{ °C}$, after programming and locking
 For all other temperature ranges this table is also valid, but only in the junction temperature range defined by the temperature range (Example: For K-Type this table is limited to $T_J = -40\text{ °C}$ to $+140\text{ °C}$).

Symbol	Parameter	Pin No.	Min.	Typ.	Max.	Unit	Test Conditions
$V_{DD,UV}$	Undervoltage Detection Level	1	-	4.2	4.3	V	1)
$V_{DD,OV}$	Overvoltage Detection Level	1	8.5	8.9	10.0	V	1)

1) If the supply voltage drops below $V_{DD,UV}$ or rises above $V_{DD,OV}$, the output voltage is switched to V_{DD} ($\geq 97\%$ of V_{DD} at $R_L = 10\text{ k}\Omega$ to GND). The CLAMP-LOW register has to be set to a voltage $\geq 200\text{ mV}$.

Note: The over- and undervoltage detection is activated only after locking the sensor!

3.10. Magnetic Characteristics

at $T_J = -40\text{ °C}$ to $+170\text{ °C}$ (A-Type), $V_{DD} = 4.5\text{ V}$ to 5.5 V , $GND = 0\text{ V}$ after programming and locking, at Recommended Operation Conditions if not otherwise specified in the column "Conditions".

Typical Characteristics for $T_J = 25\text{ °C}$ and $V_{DD} = 5\text{ V}$.

For all other temperature ranges this table is also valid, but only in the junction temperature range defined by the temperature range (Example: For K-Type this table is limited to $T_J = -40\text{ °C}$ to $+140\text{ °C}$).

Symbol	Parameter	Pin No.	Min.	Typ.	Max.	Unit	Test Conditions
B_{Offset}	Magnetic Offset	3 or 4	-0.5	0	0.5	mT	$B = 0\text{ mT}$, $I_{OUT} = 0\text{ mA}$, $T_J = 25\text{ °C}$, unadjusted sensor
$\Delta B_{Offset}/\Delta T$	Magnetic Offset Change due to T_J	3 or 4	-10	0	10	$\mu\text{T/K}$	$B = 0\text{ mT}$, $I_{OUT} = 0\text{ mA}$

4. Application Notes

4.1. Application Circuit

For EMC protection, it is recommended to connect one ceramic 100 nF capacitor each between ground and the supply voltage, respectively the output voltage pin. In addition, the input of the controller unit should be pulled-down with a 10 kΩ resistor and a ceramic 4.7 nF capacitor.

Please note that during programming, the sensor will be supplied repeatedly with the programming voltage of 12.5 V for 100 ms. All components connected to the V_{DD} line at this time must be able to resist this voltage.

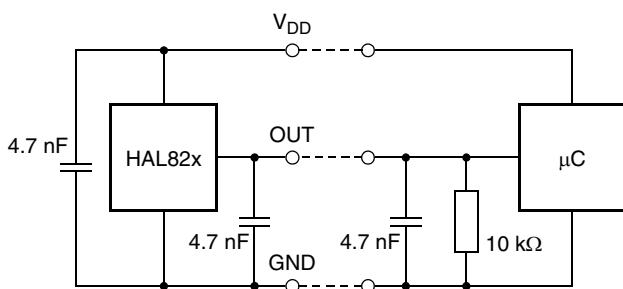

Fig. 4-1: Recommended application circuit

4.2. Use of two CUR3105 in Parallel

Two different CUR3105 current transducers which are operated in parallel to the same supply and ground line can be programmed individually. In order to select the IC which should be programmed, both ICs are inactivated by the “Deactivate” command on the common supply line. Then, the appropriate IC is activated by an “Activate” pulse on its output. Only the activated sensor will react to all following read, write, and program commands. If the second IC has to be programmed, the “Deactivate” command is sent again, and the second IC can be selected.

Note: The multi-programming of two transducers works only if the outputs of the two IC’s are pulled to GND with a 10 kΩ pull-down resistor.

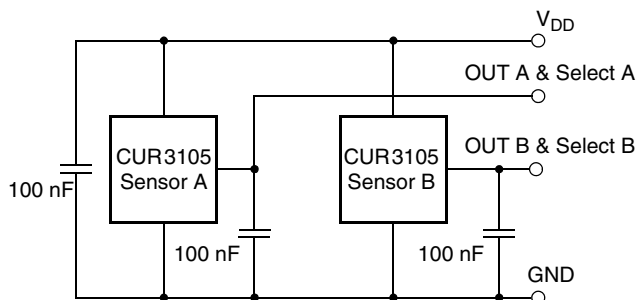

Fig. 4-2: Parallel operation of two CUR3105

4.3. Ambient Temperature

Due to the internal power dissipation, the temperature on the silicon chip (junction temperature T_J) is higher than the temperature outside the package (ambient temperature T_A).

$$T_J = T_A + \Delta T$$

At static conditions and continuous operation, the following equation applies:

$$\Delta T = I_{DD} \times V_{DD} \times R_{th,J}$$

For typical values, use the typical parameters. For worst case calculation, use the max. parameters for I_{DD} and R_{th,J}, and the max. value for V_{DD} from the application.

For V_{DD} = 5.5 V, R_{thJA} = 235 K/W, and I_{DD} = 10 mA, the temperature difference ΔT = 12.93 K.

For all sensors, the junction temperature T_J is specified. The maximum ambient temperature T_{Amax} can be calculated as:

$$T_{Amax} = T_{Jmax} - \Delta T$$

4.4. EMC and ESD

The CUR3105 is designed for a stabilized 5 V supply. Interferences and disturbances conducted along the 12 V on board system (product standard ISO 7637 part 1) are not relevant for these applications.

For applications with disturbances by capacitive or inductive coupling on the supply line or radiated disturbances, the application circuit shown in Fig. 4-1 is recommended.

5. Programming of the Current Transducer

5.1. Definition of Programming Pulses

The transducer is addressed by modulating a serial telegram on the supply voltage. The transducer answers with a serial telegram on the output pin.

The bits in the serial telegram have a different bit time for the V_{DD} -line and the output. The bit time for the V_{DD} -line is defined through the length of the Sync Bit at the beginning of each telegram. The bit time for the output is defined through the Acknowledge Bit.

A logical “0” is coded as no voltage change within the bit time. A logical “1” is coded as a voltage change between 50% and 80% of the bit time. After each bit, a voltage change occurs.

5.2. Definition of the Telegram

Each telegram starts with the Sync Bit (logical 0), 3 bits for the Command (COM), the Command Parity Bit (CP), 4 bits for the Address (ADR), and the Address Parity Bit (AP).

There are 4 kinds of telegrams:

- Write a register (see Fig. 5–2)
After the AP Bit, follow 14 Data Bits (DAT) and the Data Parity Bit (DP). If the telegram is valid and the command has been processed, the transducer answers with an Acknowledge Bit (logical 0) on the output.

- Read a register (see Fig. 5–3)
After evaluating this command, the transducer answers with the Acknowledge Bit, 14 Data Bits, and the Data Parity Bit on the output.
- Programming the EEPROM cells (see Fig. 5–4)
After evaluating this command, the transducer answers with the Acknowledge Bit. After the delay time t_w , the supply voltage rises up to the programming voltage.
- Activate a transducer (see Fig. 5–5)
If more than one transducer is connected to the supply line, selection can be done by first deactivating all transducers. The output of all transducers will be pulled to ground by the internal 10 kΩ resistors. With an Activate pulse on the appropriate output pin, an individual transducer can be selected. All following commands will only be accepted from the activated transducer.

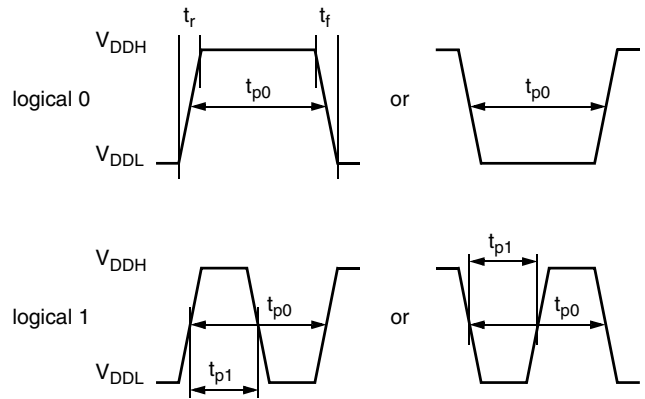

Fig. 5–1: Definition of logical 0 and 1 bit

Table 5–1: Telegram parameters

Symbol	Parameter	Pin	Min.	Typ.	Max.	Unit	Remarks
V_{DDL}	Supply Voltage for Low Level during Programming	1	5	5.6	6	V	
V_{DDH}	Supply Voltage for High Level during Programming	1	6.8	8.0	8.5	V	
t_r	Rise Time	1	–	–	0.05	ms	
t_f	Fall Time	1	–	–	0.05	ms	
t_{p0}	Bit Time on V_{DD}	1	1.7	1.8	1.9	ms	t_{p0} is defined through the Sync Bit
t_{pOUT}	Bit Time on Output Pin	3	2	3	4	ms	t_{pOUT} is defined through the Acknowledge Bit
t_{p1}	Voltage Change for Logical 1	1, 3	50	65	80	%	% of t_{p0} or t_{pOUT}
V_{DDPROG}	Supply Voltage for Programming the EEPROM	1	12.4	12.5	12.6	V	
t_{PROG}	Programming Time for EEPROM	1	95	100	105	ms	

Table 5-1: Telegram parameters, continued

Symbol	Parameter	Pin	Min.	Typ.	Max.	Unit	Remarks
t_{rp}	Rise Time of Programming Voltage	1	0.2	0.5	1	ms	
t_{fp}	Fall Time of Programming Voltage	1	0	—	1	ms	
t_w	Delay Time of Programming Voltage after Acknowledge	1	0.5	0.7	1	ms	
V_{act}	Voltage for an Activate Pulse	3	3	4	5	V	
t_{act}	Duration of an Activate Pulse	3	0.05	0.1	0.2	ms	
$V_{out,deact}$	Output Voltage after Deactivate Command	3	0	0.1	0.2	V	

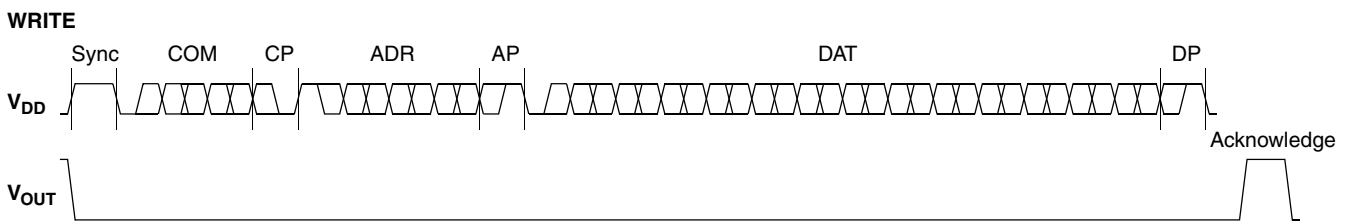

Fig. 5-2: Telegram for coding a Write command

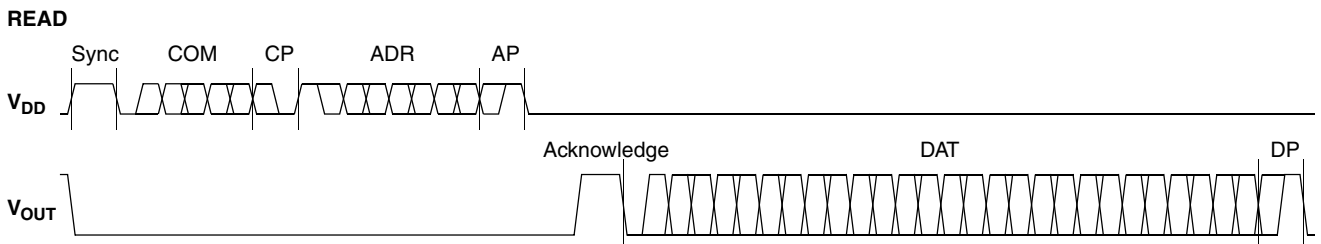

Fig. 5-3: Telegram for coding a Read command

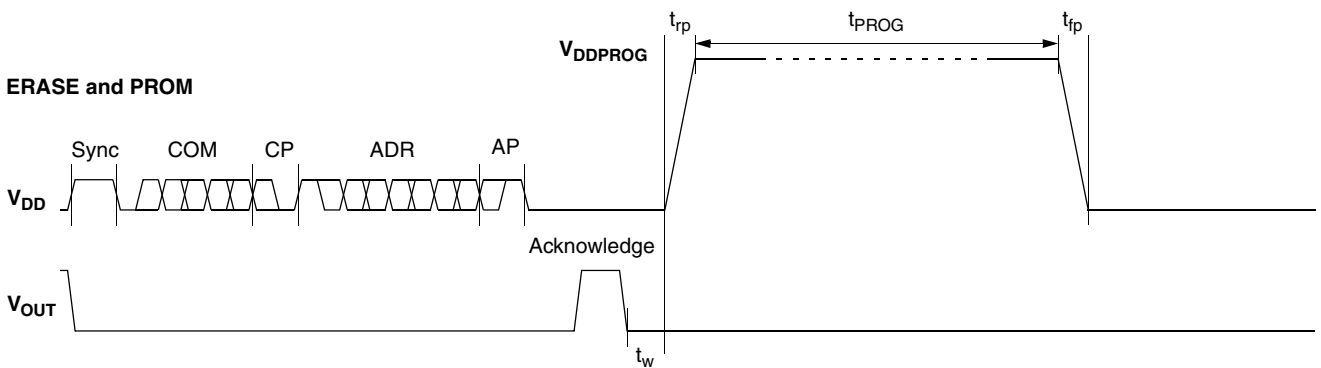

Fig. 5-4: Telegram for coding the EEPROM programming

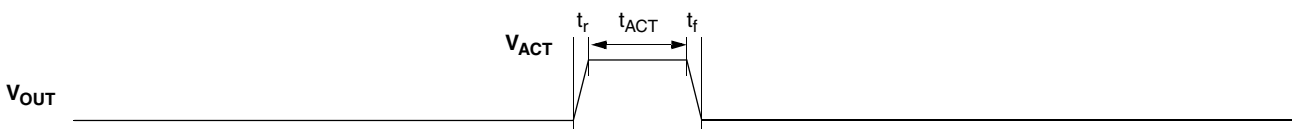

Fig. 5-5: Activate pulse

5.3. Telegram Codes

Sync Bit

Each telegram starts with the Sync Bit. This logical “0” pulse defines the exact timing for t_{p0} .

Command Bits (COM)

The Command code contains 3 bits and is a binary number. Table 5–2 shows the available commands and the corresponding codes for the CUR3105.

Command Parity Bit (CP)

This parity bit is “1” if the number of zeros within the 3 Command Bits is uneven. The parity bit is “0”, if the number of zeros is even.

Address Bits (ADR)

The Address code contains 4 bits and is a binary number. Table 5–3 shows the available addresses for the CUR3105 registers.

Address Parity Bit (AP)

This parity bit is “1” if the number of zeros within the 4 Address bits is uneven. The parity bit is “0” if the number of zeros is even.

Data Bits (DAT)

The 14 Data Bits contain the register information.

The registers use different number formats for the Data Bits. These formats are explained in Section 5.4.

In the Write command, the last bits are valid. If, for example, the TC register (10 bits) is written, only the last 10 bits are valid.

In the Read command, the first bits are valid. If, for example, the TC register (10 bits) is read, only the first 10 bits are valid.

Data Parity Bit (DP)

This parity bit is “1” if the number of zeros within the binary number is even. The parity bit is “0” if the number of zeros is uneven.

Acknowledge

After each telegram, the output answers with the Acknowledge signal. This logical “0” pulse defines the exact timing for t_{pOUT} .

Table 5–2: Available commands

Command	Code	Explanation
READ	2	read a register
WRITE	3	write a register
PROM	4	program all nonvolatile registers (except the lock bits)
ERASE	5	erase all nonvolatile registers (except the lock bits)

5.4. Number Formats

Binary number:

The most significant bit is given as first, the least significant bit as last digit.

Example: 101001 represents 41 decimal.

Signed binary number:

The first digit represents the sign of the following binary number (1 for negative, 0 for positive sign).

Example: 0101001 represents +41 decimal
 1101001 represents -41 decimal

Two's complementary number:

The first digit of positive numbers is "0", the rest of the number is a binary number. Negative numbers start with "1". In order to calculate the absolute value of the number, calculate the complement of the remaining digits and add "1".

Example: 0101001 represents +41 decimal
 1010111 represents -41 decimal

5.5. Register Information

CLAMP-LOW

- The register range is from 0 up to 255.
- The register value is calculated by:

$$CLAMP-LOW = \frac{LowClampingVoltage \times 2}{V_{DD}} \times 255$$

CLAMP-HIGH

- The register range is from 0 up to 511.
- The register value is calculated by:

$$CLAMP-HIGH = \frac{HighClampingVoltage}{V_{DD}} \times 511$$

VOQ

- The register range is from -1024 up to 1023.
- The register value is calculated by:

$$VOQ = \frac{V_{OQ}}{V_{DD}} \times 1024$$

SENSITIVITY

- The register range is from -8192 up to 8191.
- The register value is calculated by:

$$SENSITIVITY = Sensitivity \times 2048$$

MODE

- The register range is from 0 up to 255 and contains the settings for FILTER and RANGE:

$$MODE = OUTPUTMODE \times 32 + BITRATE \times 16 + FILTER \times 8 + RANGE \times 2 + EnableProgGPRRegisters$$

D/A-READOUT

- This register is read only.
- The register range is from 0 up to 16383.

DEACTIVATE

- This register can only be written.
- The register has to be written with 2063 decimal (80F hexadecimal) for the deactivation.
- The transducer can be reset with an Activate pulse on the output pin or by switching off and on the supply voltage.

Table 5–3: Available register addresses

Register	Code	Data Bits	Format	Customer	Remark
CLAMP-LOW	1	8	binary	read/write/program	Low clamping voltage
CLAMP-HIGH	2	9	binary	read/write/program	High clamping voltage
VOQ	3	11	two compl. binary	read/write/program	
SENSITIVITY	4	14	signed binary	read/write/program	Range, filter, output mode, interface bit time settings
MODE	5	8	binary	read/write/program	Range and filter settings
LOCKR	6	2	binary	read/write/program	Lock Bit
GP REGISTERS 1..3	8	13	binary	read/write/program	It is only possible to program this register if the mode register bit zero is set to 1.
D/A-READOUT	9	14	binary	read	Bit sequence is reversed during read sequence.
GP REGISTER 0	12	13	binary	read/write/program	It is only possible to program this register if the mode register bit zero is set to 1.
DEACTIVATE	15	12	binary	write	Deactivate the transducer

Table 5–4: Data formats

Register	Char	DAT3				DAT2				DAT1				DAT0			
	Bit	15	14	13	12	11	10	09	08	07	06	05	04	03	02	01	00
CLAMP LOW	Write	–	–	–	–	–	–	–	–	V	V	V	V	V	V	V	V
	Read	–	–	V	V	V	V	V	V	V	V	–	–	–	–	–	–
CLAMP HIGH	Write	–	–	–	–	–	–	–	V	V	V	V	V	V	V	V	V
	Read	–	–	V	V	V	V	V	V	V	V	V	–	–	–	–	–
VOQ	Write	–	–	–	–	–	V	V	V	V	V	V	V	V	V	V	V
	Read	–	–	V	V	V	V	V	V	V	V	V	V	V	–	–	–
SENSITIVITY	Write	–	–	V	V	V	V	V	V	V	V	V	V	V	V	V	V
	Read	–	–	V	V	V	V	V	V	V	V	V	V	V	V	V	V
MODE	Write	–	–	–	–	–	–	–	–	V	V	V	V	V	V	V	V
	Read	–	–	V	V	V	V	V	V	V	V	–	–	–	–	–	–
LOCKR	Write	–	–	–	–	–	–	–	–	–	–	–	–	–	–	V	V
	Read	–	–	V	V	–	–	–	–	–	–	–	–	–	–	–	–
GP 1..3 Registers	Write	–	–	–	V	V	V	V	V	V	V	V	V	V	V	V	V
	Read	–	–	V	V	V	V	V	V	V	V	V	V	V	V	V	–
D/A-READOUT	Read	–	–	V	V	V	V	V	V	V	V	V	V	V	V	V	V
GP 0 Register	Write	–	–	–	V	V	V	V	V	V	V	V	V	V	V	V	V
	Read	–	–	V	V	V	V	V	V	V	V	V	V	V	V	V	–
DEACTIVATE	Write	–	–	–	–	1	0	0	0	0	0	0	0	1	1	1	1

V: valid, –: ignore, bit order: MSB first

5.5.1. Programming Information

If the content of any register (except the lock registers) is to be changed, the desired value must first be written into the corresponding RAM register. Before reading out the RAM register again, the register value must be permanently stored in the EEPROM.

Permanently storing a value in the EEPROM is done by first sending an ERASE command followed by sending a PROM command. **The address within the ERASE and PROM commands must be zero.** ERASE and PROM act on all registers in parallel.

Note: To store data in the GP register it is necessary to set bit number 0 of the MODE register to one, before sending an ERASE and PROM command. Otherwise the data stored in the GP register will not be changed.

If all registers of CUR3105 are to be changed, all writing commands can be sent one after the other, followed by sending one ERASE and PROM command at the end.

During all communication sequences, the customer has to check if the communication with the transducer was successful. This means that the acknowledge and the parity bits sent by the transducer have to be checked by the customer. If the Micronas programmer board is used, the customer has to check the error flags sent from the programmer board.

Note: For production and qualification tests, it is mandatory to set the LOCK bit after final adjustment and programming of CUR3105. The LOCK function is active after the next power-up of the transducer. The success of the Lock Process should be checked by reading at least one transducer register after locking and/or by an analog check of the transducers output signal. Electrostatic Discharges (ESD) may disturb the programming pulses. Please take precautions against ESD.

6. Data Sheet History

1. Data Sheet: "CUR 3105 Hall-Effect Current Transducer", Oct. 12, 2009, DSH000155_001EN. First release of the data sheet.
2. Data Sheet: "CUR 3105 Hall-Effect Current Transducer", March 24, 2011, DSH000155_002EN. Second release of the data sheet.

Major Changes:

- SOIC8 package added
- TO92UT package drawings updated