

Data Sheet

HAL[®] 1821...HAL1823

Linear Hall Effect Sensors
Family

Copyright, Warranty, and Limitation of Liability

The information and data contained in this document are believed to be accurate and reliable. The software and proprietary information contained therein may be protected by copyright, patent, trademark and/or other intellectual property rights of Micronas. All rights not expressly granted remain reserved by Micronas.

Micronas assumes no liability for errors and gives no warranty representation or guarantee regarding the suitability of its products for any particular purpose due to these specifications.

By this publication, Micronas does not assume responsibility for patent infringements or other rights of third parties which may result from its use. Commercial conditions, product availability and delivery are exclusively subject to the respective order confirmation.

Any information and data which may be provided in the document can and do vary in different applications, and actual performance may vary over time.

All operating parameters must be validated for each customer application by customers' technical experts. Any new issue of this document invalidates previous issues. Micronas reserves the right to review this document and to make changes to the document's content at any time without obligation to notify any person or entity of such revision or changes. For further advice please contact us directly.

Do not use our products in life-supporting systems, aviation and aerospace applications! Unless explicitly agreed to otherwise in writing between the parties, Micronas' products are not designed, intended or authorized for use as components in systems intended for surgical implants into the body, or other applications intended to support or sustain life, or for any other application in which the failure of the product could create a situation where personal injury or death could occur.

No part of this publication may be reproduced, photocopied, stored on a retrieval system or transmitted without the express written consent of Micronas.

Micronas Trademarks

– HAL

Micronas Patents

Choppered Offset Compensation protected by Micronas patents no. US5260614A, US5406202A, EP0525235B1 and EP0548391B1.

Third-Party Trademarks

All other brand and product names or company names may be trademarks of their respective companies.

Contents

Page	Section	Title
4	1.	Introduction
4	1.1.	Major Applications
4	1.2.	Features
4	1.3.	Family Overview
4	1.4.	Marking Code
4	1.5.	Operating Junction Temperature Range (T_J)
5	1.6.	Hall Sensor Package Codes
5	1.7.	Solderability and Welding
5	1.8.	Pin Connections and Short Descriptions
6	2.	Functional Description
6	2.1.	General Function
7	3.	Specifications
7	3.1.	Outline Dimensions
12	3.2.	Dimensions of Sensitive Area
12	3.3.	Position of Sensitive Areas
12	3.4.	Absolute Maximum Ratings
13	3.4.1.	Storage and Shelf Life
13	3.5.	Recommended Operating Conditions
14	3.6.	Characteristics
15	3.7.	Magnetic Characteristics
17	3.7.1.	Definition of Sensitivity Error ES
18	4.	Application Notes
18	4.1.	Ambient Temperature
18	4.2.	EMC and ESD
18	4.3.	Application Circuit
19	5.	Data Sheet History

Linear Hall Effect Sensors Family

1. Introduction

The HAL182x is a new family of linear Hall-effect sensors. It is a universal magnetic field sensor with a ratio-metric, linear analog output. This sensor family can be used for magnetic field measurements, current measurements and detection of mechanical movements. Very accurate angle measurements or distance measurements can also be done. The sensors are very robust and can be used in harsh environments.

The output voltage is proportional to the magnetic flux density through the hall plate. The chopped offset compensation leads to stable magnetic characteristics over supply voltage and temperature.

The different family members vary by sensitivity (25 mV/mT, 31.25 mV/mT and 50 mV/mT). The quiescent output voltage (offset) is for all family members 50% of supply voltage.

The sensor is designed for industrial and automotive applications and operates in the junction temperature range from $-40\text{ }^{\circ}\text{C}$ up to $170\text{ }^{\circ}\text{C}$. The HAL182x is available in the very small leaded packages TO92UA-1 and TO92UA-2 and in the SMD-package SOT89B-1.

1.1. Major Applications

Due to the sensor's robust characteristics, the HAL182x is the optimal system solution for applications such as:

- linear position measurements,
- angle sensors,
- distance measurements,
- magnetic field and current measurement.

1.2. Features

- ratiometric linear output proportional to the magnetic field
- temperature and stress stable quiescent output voltage
- very accurate sensitivity and offset
- customized versions possible
- on-chip temperature compensation
- active offset compensation

- operates from $-40\text{ }^{\circ}\text{C}$ up to $170\text{ }^{\circ}\text{C}$ junction temperature
- operates from 4.5 V up to 5.5 V supply voltage in specification operates with static magnetic fields and dynamic magnetic fields up to 2.25 kHz
- overvoltage and reverse-voltage protection at V_{SUP} pin
- magnetic characteristics extremely robust against mechanical stress
- short-circuit protected push-pull output
- EMC and ESD optimized design

1.3. Family Overview

Type	Offset	Sensitivity	see Page
1821	50% of V_{SUP}	50 mV/mT	15
1822	50% of V_{SUP}	31.25 mV/mT	15
1823	50% of V_{SUP}	25 mV/mT	15

1.4. Marking Code

The HAL182x has a marking on the package surface (branded side). This marking includes the name of the sensor and the temperature range.

Type	Temperature Range	
	A	K
HAL 1821	1821A	1821K
HAL 1822	1822A	1822K
HAL 1823	1823A	1823K

1.5. Operating Junction Temperature Range (T_J)

The Hall sensors from Micronas are specified to the chip temperature (junction temperature T_J).

A: $T_J = -40\text{ }^{\circ}\text{C}$ to $+170\text{ }^{\circ}\text{C}$

K: $T_J = -40\text{ }^{\circ}\text{C}$ to $+140\text{ }^{\circ}\text{C}$

The relationship between ambient temperature (T_A) and junction temperature is explained in Section 4.1. on page 18.

1.6. Hall Sensor Package Codes

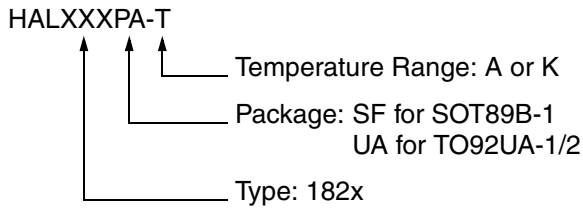

Example: **HAL1821UA-K**

- Type: 1821
- Package: TO92UA-1/2
- Temperature Range: $T_J = -40\text{ °C to }+140\text{ °C}$

Hall sensors are available in a wide variety of packaging versions and quantities. For more detailed information, please refer to the brochure: “Hall Sensors: Ordering Codes, Packaging, Handling”.

1.7. Solderability and Welding

Soldering

During soldering reflow processing and manual reworking, a component body temperature of 260 °C should not be exceeded.

Welding

Device terminals should be compatible with laser and resistance welding. Please note that the success of the welding process is subject to different welding parameters which will vary according to the welding technique used. A very close control of the welding parameters is absolutely necessary in order to reach satisfying results. Micronas, therefore, does not give any implied or express warranty as to the ability to weld the component.

1.8. Pin Connections and Short Descriptions

Pin No.	Pin Name	Type	Short Description
1	V _{SUP}	IN	Supply Voltage Pin
2	GND		Ground
3	OUT	OUT	Push-Pull Output

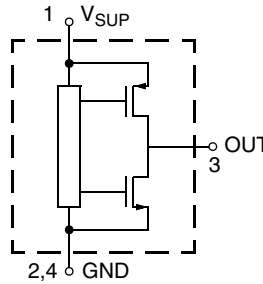

Fig. 1–1: Pin configuration

2. Functional Description

2.1. General Function

The HAL182x is a monolithic integrated circuit which provides an output voltage proportional to the magnetic flux through the Hall plate and proportional to the supply voltage (ratiometric behavior).

The external magnetic field component perpendicular to the branded side of the package generates a Hall voltage. The Hall IC is sensitive to magnetic north and south polarity. This voltage is amplified and stabilized by a push-pull output transistor stage.

Internal temperature compensation circuitry and the chopped offset compensation enables operation over the full temperature range with minimal degradation in accuracy and offset. The circuitry also rejects offset shifts due to mechanical stress from the package. In addition, the sensor IC is equipped with devices for overvoltage and reverse-voltage protection at supply pin.

Output/Magnetic Field Polarity

Applying a south-pole magnetic field perpendicular to the branded side of the package will increase the output voltage from the quiescent (offset) voltage towards the supply voltage. A negative magnetic field will decrease the output voltage.

In addition HAL182x features an internal error detection. The following error modes can be detected:

- Over-/underflow in adder or multiplier
- Over-/underflow in A/D converter
- Overtemperature detection

In case of an error the sensors output will be forced to the lower error band. The error band is defined by

VDIAG (see Section 3.6. on page 14).

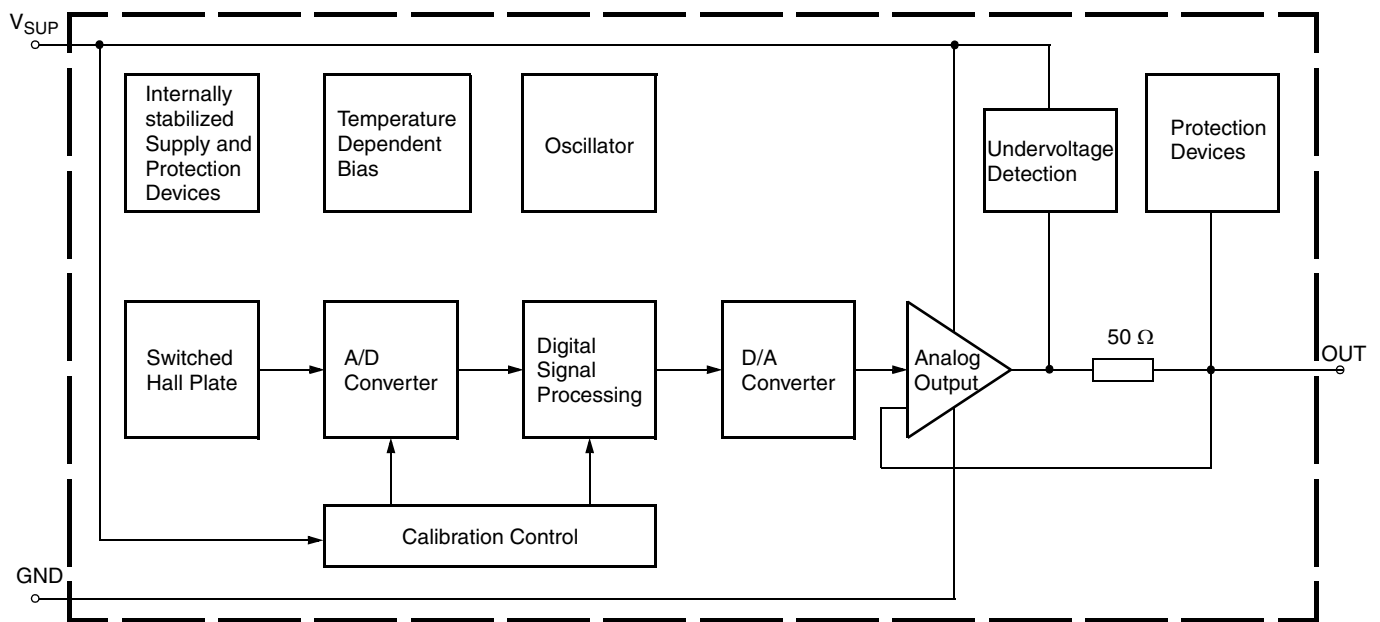

Fig. 2-1: HAL182x block diagram

3. Specifications

3.1. Outline Dimensions

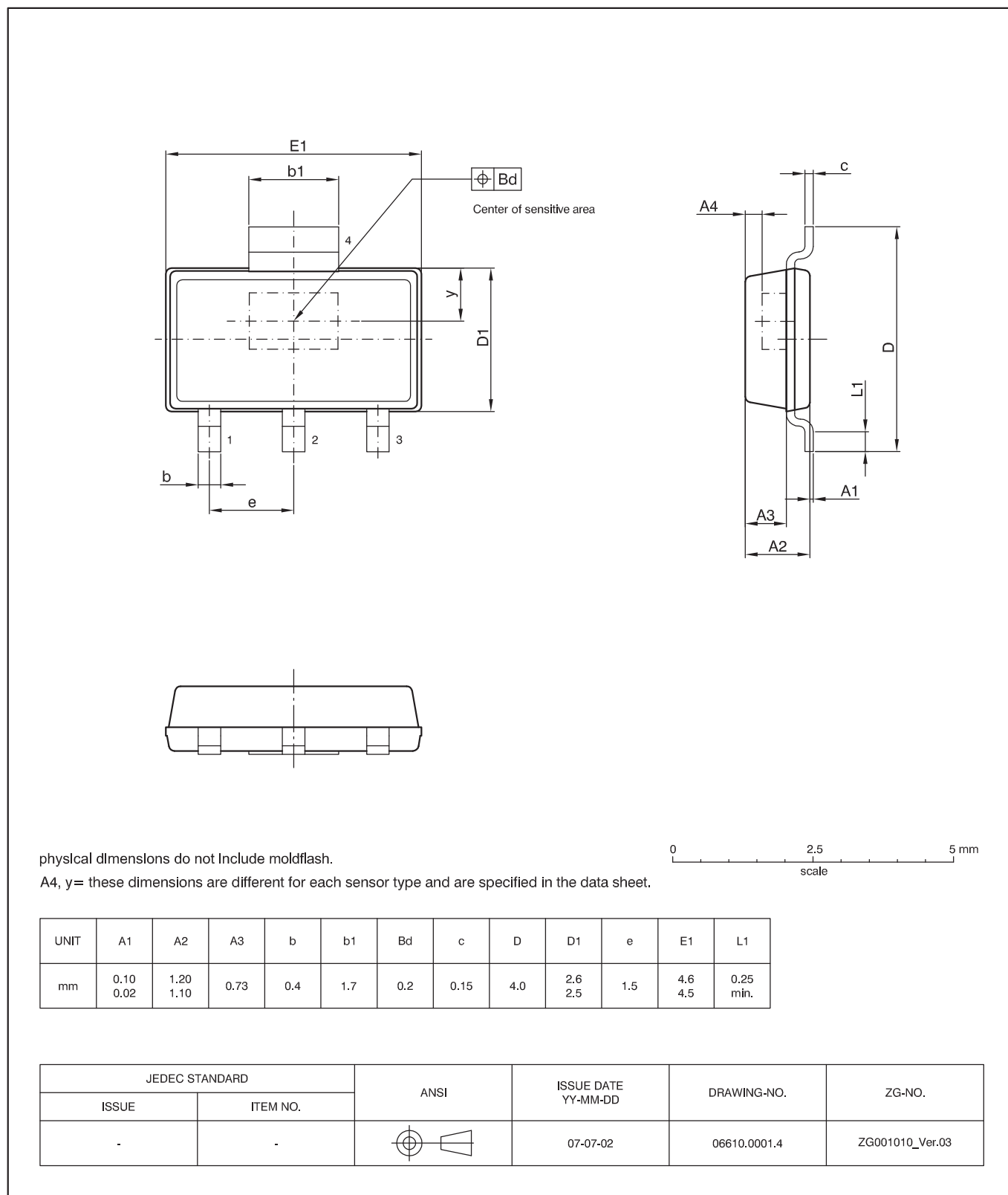

Fig. 3-1:
SOT89B-1: Plastic Small Outline Transistor package, 4 leads
 Ordering code: SF
 Weight approximately 0.034 g

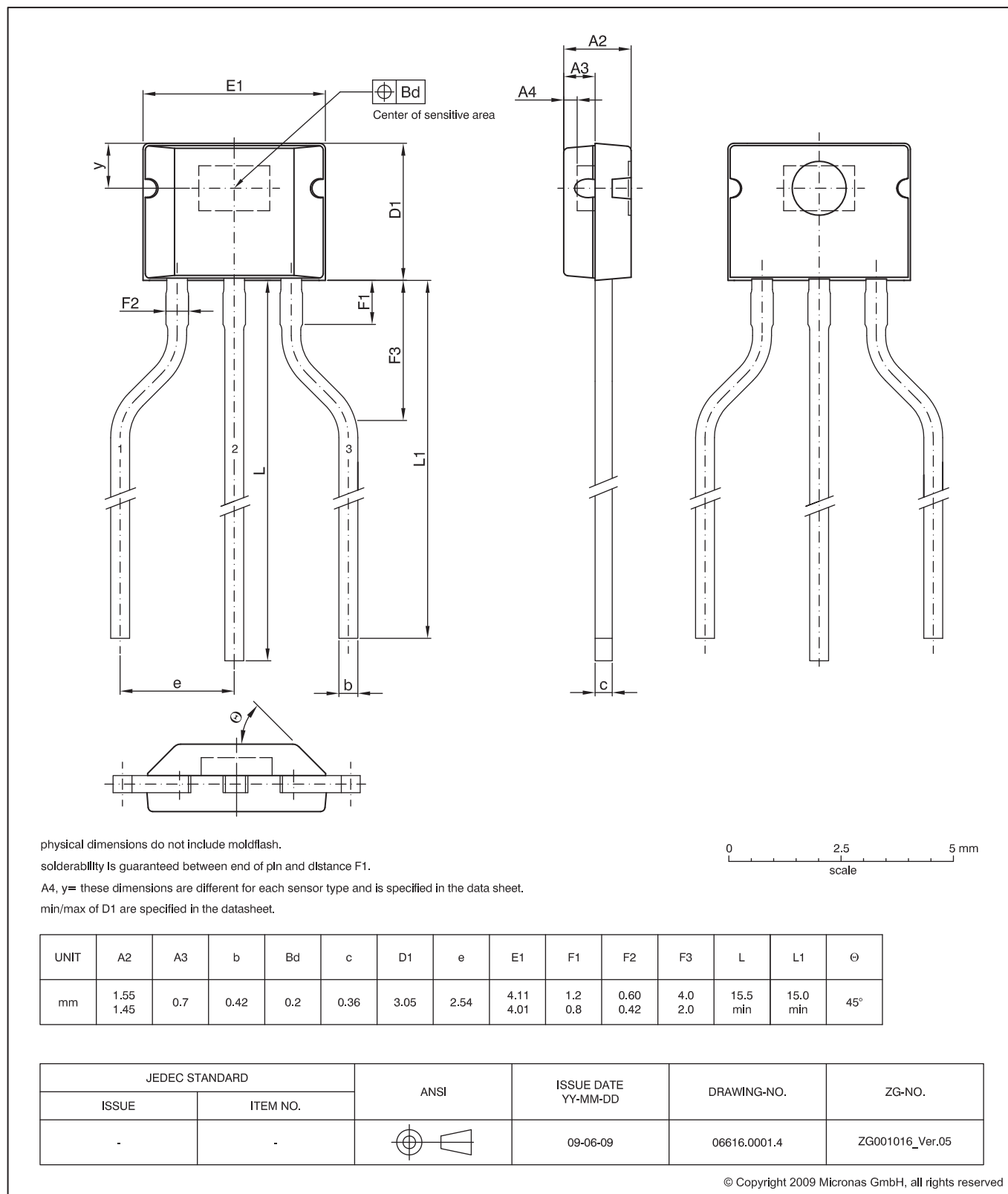

Fig. 3-2:
TO92UA-1: Plastic Transistor Standard UA package, 3 leads, spread
 Weight approximately 0.106 g

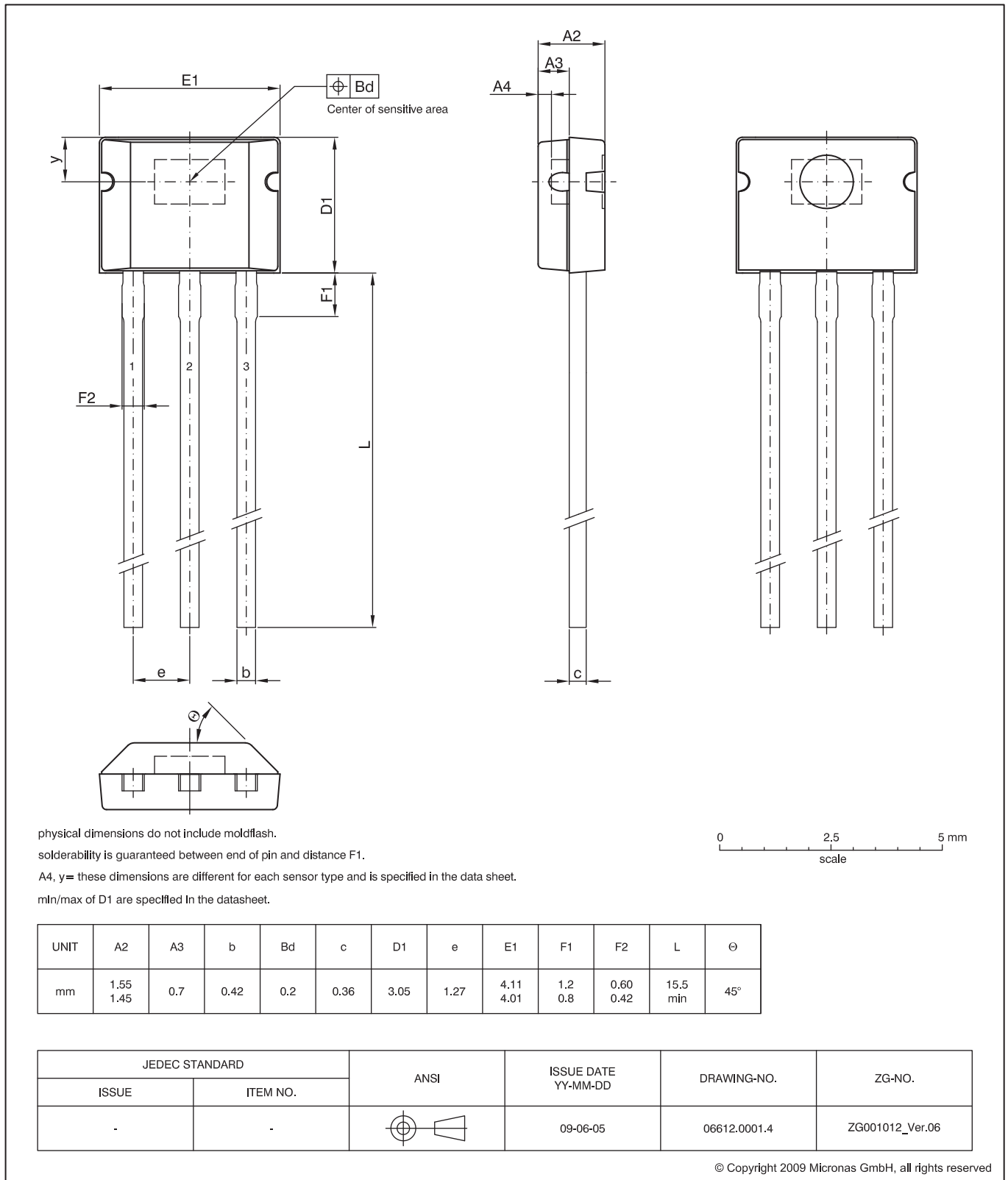

Fig. 3-3:
TO92UA-2: Plastic Transistor Standard UA package, 3 leads, not spread
 Weight approximately 0.106 g

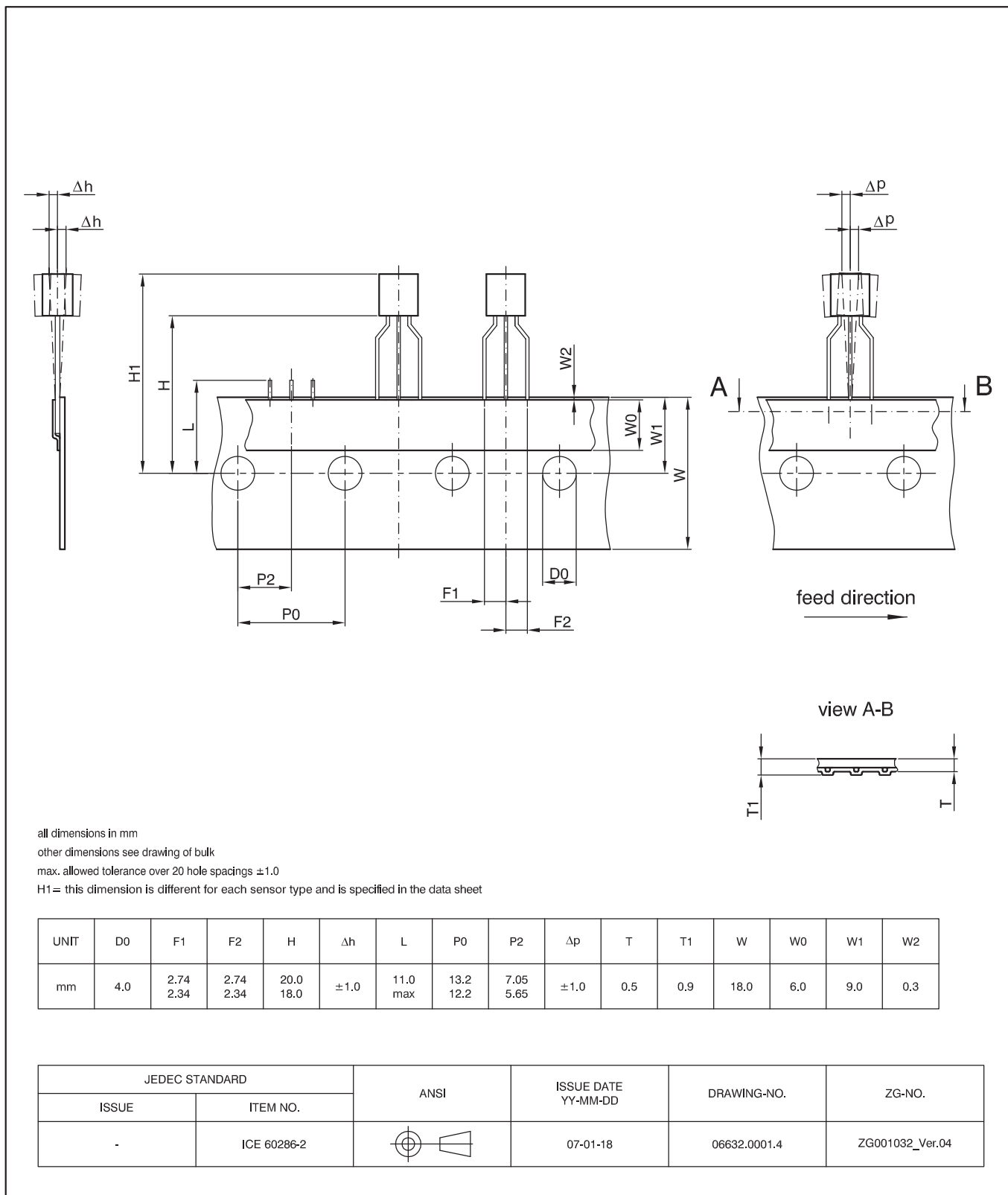

Fig. 3-4:
T092UA/UT-1: Dimensions ammpack inline, spread

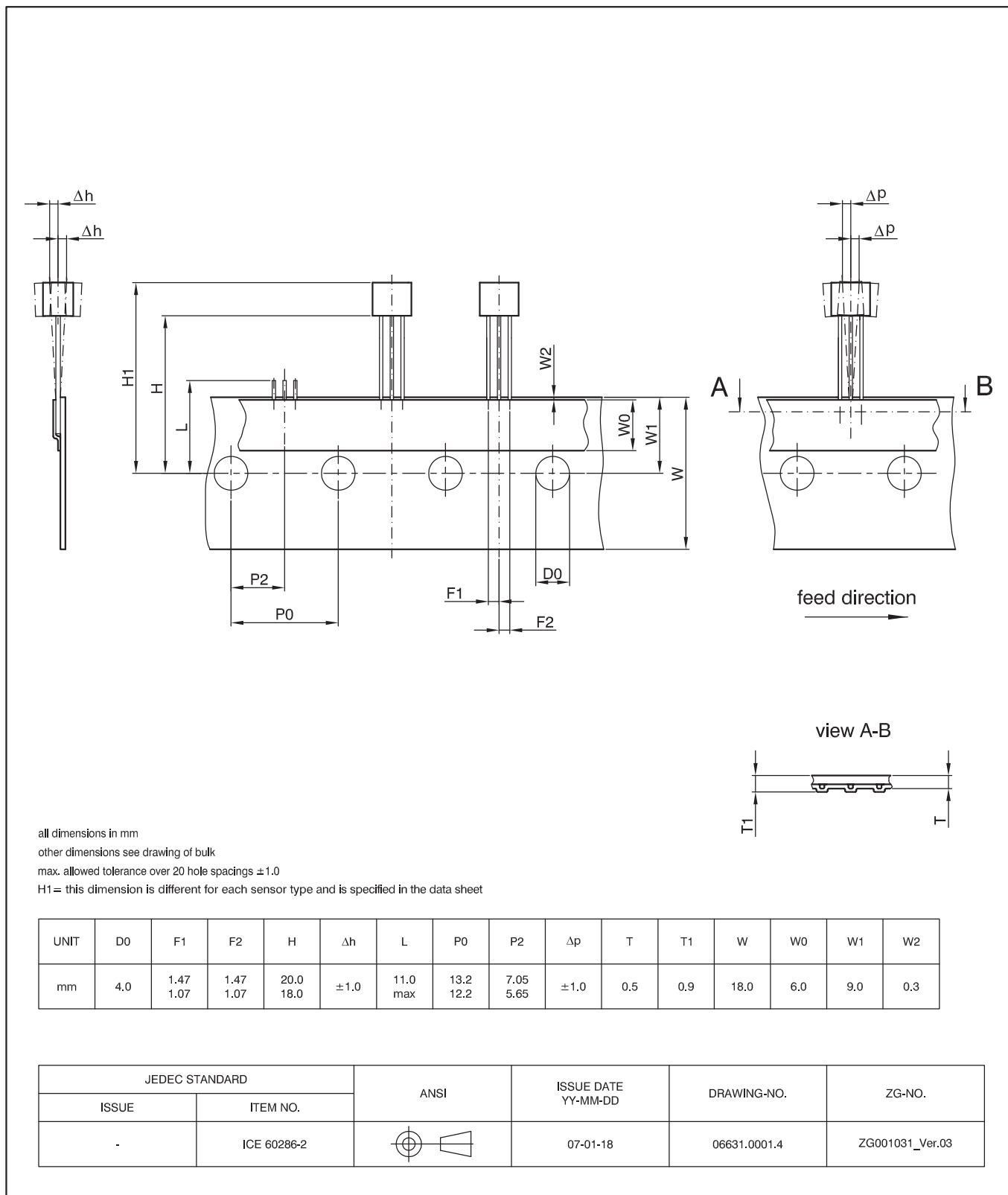

Fig. 3-5:
T092UA/UT-2: Dimensions ammpack inline, not spread

3.2. Dimensions of Sensitive Area

0.2 mm x 0.1 mm

3.3. Position of Sensitive Areas

	TO92UA-1/-2	SOT89B-1
y	1.0 mm nominal	0.95 mm nominal
A4	0.4 mm nominal	0.4 mm nominal
D1	3.05 ±0.05 mm	2.55 ±0.05 mm
H1	min. 21 mm max. 23.1 mm	not applicable

3.4. Absolute Maximum Ratings

Stresses beyond those listed in the “Absolute Maximum Ratings” may cause permanent damage to the device. This is a stress rating only. Functional operation of the device at these conditions is not implied. Exposure to absolute maximum rating conditions for extended periods will affect device reliability.

This device contains circuitry to protect the inputs and outputs against damage due to high static voltages or electric fields; however, it is advised that normal precautions be taken to avoid application of any voltage higher than absolute maximum-rated voltages to this circuit.

All voltages listed are referenced to ground (GND).

Symbol	Parameter	Pin No.	Min.	Max.	Unit	Condition
V _{SUP}	Supply Voltage	1	-8.5	8.5	V	t < 96 h, not additive
			-14.4 -15	14.4 16	V	t < 10 min. ¹⁾ t < 1 min. ¹⁾ not additive
V _{OUT}	Output Voltage ¹⁾	3	-0.5 ²⁾ -0.5 ²⁾ -0.5 ²⁾	8.5 14.4 16	V	t < 96 h t < 10 min. t < 1 min. not additive
V _{OUT} -V _{SUP}	Excess of Output Voltage over Supply Voltage	1,3	-	0.5	V	
I _{OUT}	Continuous Output Current	3	-5	5	mA	
t _{Sh}	Output Short Circuit Duration	3	-	10	min	
T _J	Junction Temperature Range		-40	190 ³⁾	°C	not additive
V _{ESD}	ESD Protection ⁴⁾	1,2,3	-4.0	4.0	kV	
¹⁾ as long as T _{Jmax} is not exceeded ²⁾ internal protection resistor = 50 Ω ³⁾ for 96h - Please contact Micronas for other temperature requirements ⁴⁾ AEC-Q100-002 (100 pF and 1.5 kΩ)						

3.4.1. Storage and Shelf Life

The permissible storage time (shelf life) of the sensors is unlimited, provided the sensors are stored at a maximum of 30 °C and a maximum of 85% relative humidity. At these conditions, no Dry Pack is required.

Solderability is guaranteed for one year from the date code on the package.

3.5. Recommended Operating Conditions

Functional operation of the device beyond those indicated in the “Recommended Operating Conditions/Characteristics” is not implied and may result in unpredictable behavior of the device and may reduce reliability and lifetime.

All voltages listed are referenced to ground (GND).

Symbol	Parameter	Pin No.	Min.	Typ.	Max.	Unit	Remarks
V _{SUP}	Supply Voltage	1	4.5	5	5.5	V	
I _{OUT}	Continuous Output Current	3	-1.0	-	1.0	mA	
R _L	Load Resistor	3	5.5	10	-	kΩ	
C _L	Load Capacitance	3	0.33	10	47	nF	
T _J	Junction Operating Temperature ¹⁾	-	-40	-	125	°C	for 8000 h (not additive)
			-40	-	150	°C	for 2000 h (not additive)
			-40	-	170	°C	< 1000 h (not additive)

¹⁾ Depends on the temperature profile of the application. Please contact Micronas for life time calculations.

3.6. Characteristics

at $T_J = -40\text{ °C}$ to $+170\text{ °C}$ (for temperature type A), $V_{SUP} = 4.5\text{ V}$ to 5.5 V , $GND = 0\text{ V}$, at Recommended Operation Conditions if not otherwise specified in the column “Conditions”.

Typical Characteristics for $T_J = 25\text{ °C}$ and $V_{SUP} = 5\text{ V}$.

For all other temperature ranges this table is also valid, but only in the junction temperature range defined by the temperature grade (Example: For K-Type this table is limited to $T_J = -40\text{ °C}$ to $+140\text{ °C}$).

Symbol	Parameter	Pin No.	Min.	Typ.	Max.	Unit	Conditions
I_{SUP}	Supply Current over Temperature Range	1	–	7	10	mA	
	Resolution	3	–	10	–	Bit	
INL	Non-Linearity of Output Voltage over Temperature	3	–1.0	0	1.0	%	% of supply voltage ¹⁾
E_R	Ratiometric Error of Output over Temperature (Error in V_{OUT} / V_{SUP})	3	–1.0	0	1.0	%	
V_{OQ}	Output Quiescent Voltage	3	2.425	2.5	2.575	V	$B = 0\text{ mT}$, $T_J = 25\text{ °C}$, $I_{OUT} = \pm 1\text{ mA}$
V_{OUTH}	Output High Voltage	3	4.7	4.9	–	V	$V_{SUP} = 5\text{ V}$, $I_{OUT} = \pm 1\text{ mA}$ ²⁾
V_{OUTL}	Output Low Voltage	3	–	0.1	0.3	V	$V_{SUP} = 5\text{ V}$, $I_{OUT} = \pm 1\text{ mA}$ ²⁾
$t_{r(O)}$	Response Time of Output ³⁾	3	–	0.5	1	ms	$C_L = 10\text{ nF}$, time from 10% to 90% of final output voltage for a step like signal B_{step} from 0 mT to B_{max}
t_{POD}	Power-Up Time (Time to reach stabilized Output Voltage) ³⁾	–	–	1	1.5	ms	$C_L = 10\text{ nF}$, 90% of V_{OUT}
BW	Small Signal Bandwidth (–3 dB) ³⁾	3	2.25	2.5	–	kHz	$B_{AC} < 10\text{ mT}$
V_{OUTn}	Output RMS Noise ³⁾	3	–	2.6	5	mV	$B = 5$ to 95% of B_{max}
R_{OUT}	Output Resistance over Recommended Operating Range ³⁾	3	–	60	–	Ω	$V_{OUTLmax} \leq V_{OUT} \leq V_{OUTHmin}$
V_{PORLH}	Power-On Reset Level from V_{SUPLow} to $V_{SUPHigh}$	1	3.9	4.35	4.5	V	
V_{PORHL}	Power-On Reset Level from $V_{SUPHigh}$ to V_{SUPLow}	1	3.8	4.2	4.4	V	
V_{PORHYS}	Power-On Hysteresis	1	0.1	0.175	0.2	V	
V_{DIAG}	Output Voltage in case of Error Detection	3	0	–	300	mV	
TO92UA Package							
R_{thja}	Thermal Resistance junction to air	–	–	–	250	K/W	Measured with a 1s0p board
R_{thjc}	junction to case	–	–	–	70	K/W	
SOT89B Package							
R_{thja}	Thermal Resistance junction to air	–	–	–	210	K/W	Measured with a 1s0p board 30 mm x 10 mm x 1.5 mm, pad size (see Fig. 3–6)
R_{thjc}	junction to case	–	–	–	60	K/W	
¹⁾ if more than 50% of the selected magnetic field range are used and V_{OUT} is between 0.3 V and 4.7 V ²⁾ Linear output range ³⁾ Guaranteed by design							

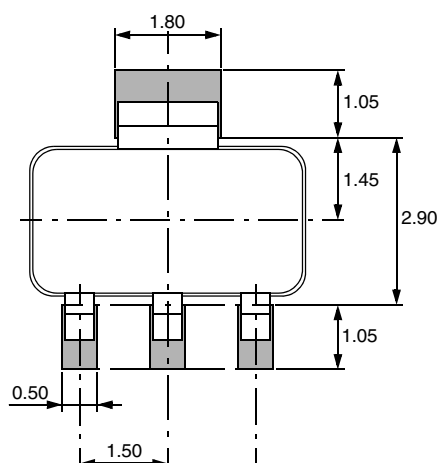

Fig. 3-6: Recommended footprint SOT89B-1, Dimensions in mm.

All dimensions are for reference only. The pad size may vary depending on the requirements of the soldering process.

3.7. Magnetic Characteristics

at Recommended Operating Conditions if not otherwise specified in the column 'Test Conditions',

$T_J = -40\text{ °C}$ to $+170\text{ °C}$ (for temperature type A), $V_{SUP} = 4.5\text{ V}$ to 5.5 V .

Typical Characteristics for $T_A = 25\text{ °C}$ and $V_{SUP} = 5\text{ V}$.

For all other temperature ranges this table is also valid, but only in the junction temperature range defined by the temperature grade (Example: For K-type this table is limited to $T_J = -40\text{ °C}$ to $+140\text{ °C}$)

Symbol	Parameter	Pin No.	Values			Unit	Test Conditions
			Min.	Typ.	Max.		
Sens	Sensitivity	3	47.5 30.0 24.0	50.0 31.25 25.0	52.5 32.5 26.0	mV/mT	HAL1821; $T_J = 25\text{ °C}$ HAL1822; $T_J = 25\text{ °C}$ HAL1823; $T_J = 25\text{ °C}$
ES	Sensitivity Error over Temperature Range	3	-6	0	6	%	Part-to-part variation
Δ Sens	Sensitivity Drift (beside temperature drift) ¹⁾		-	± 2	-	%	$T_J = 25\text{ °C}$; after temperature cycling and over life time
B_{OFFSET}	Magnetic offset	3	-1.4 -2.3 -2.8	0 0 0	1.4 2.3 2.8	mT	HAL1821 HAL1822 HAL1823 $B = 0\text{ mT}$, $T_A = 25\text{ °C}$
ΔB_{OFFSET}	Magnetic offset drift over Temperature Range $B_{OFFSET}(T) - B_{OFFSET}(25\text{ °C})$	3	-950 -950 -1015	0 0 0	950 950 1015	μT	HAL1821 HAL1822 HAL1823 $B = 0\text{ mT}$
$B_{Hysteresis}$	Magnetic Hysteresis ¹⁾	3	-20	0	20	μT	Range = 40 mT

¹⁾ Guaranteed by design

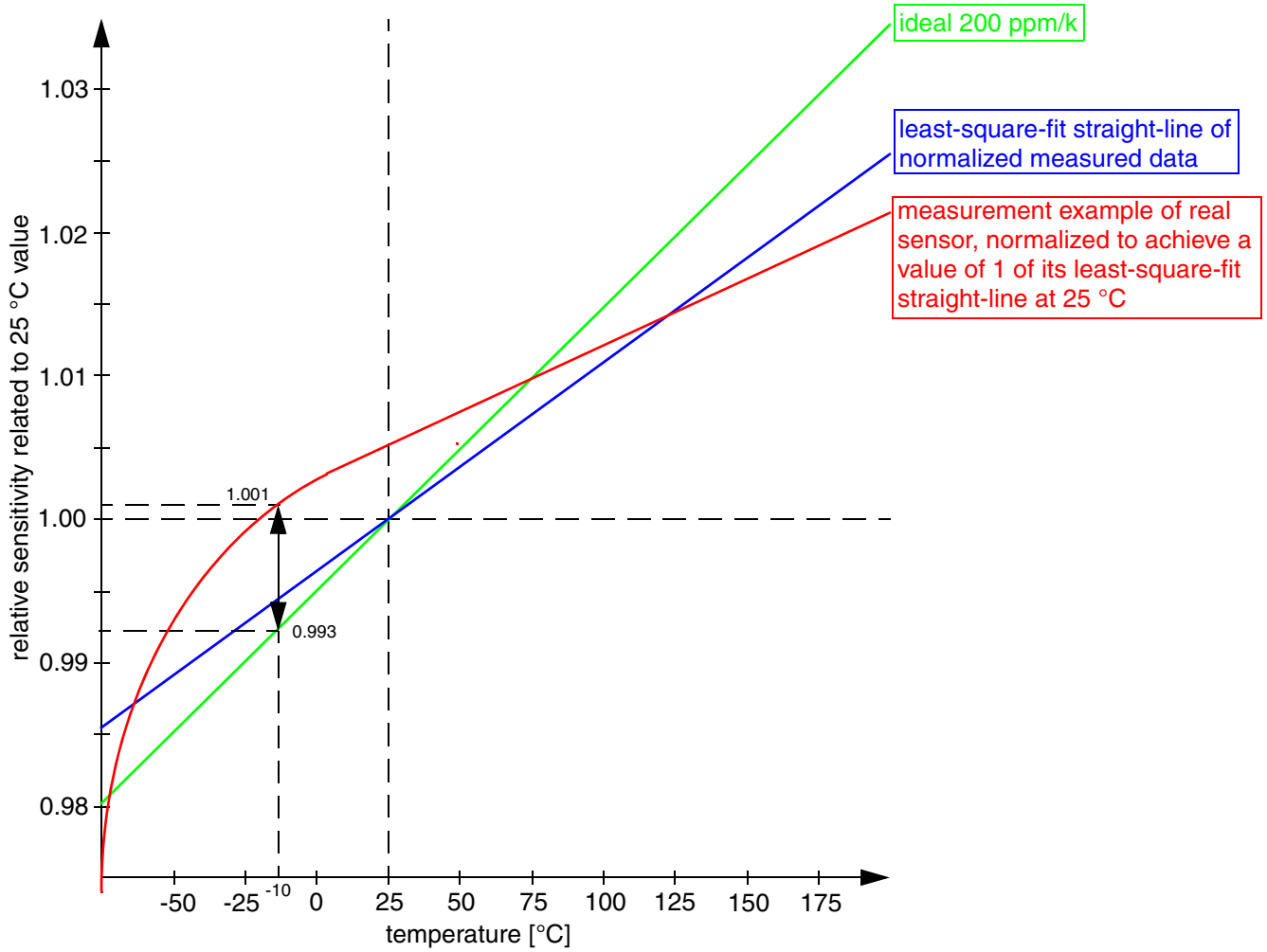

Fig. 3-7: Definition of Sensitivity Error ES.

3.7.1. Definition of Sensitivity Error ES

ES is the maximum of the absolute value of 1 minus the quotient of the normalized measured value¹⁾ over the normalized ideal linear²⁾ value:

$$ES = \max \left(\text{abs} \left(\frac{\text{meas}}{\text{ideal}} - 1 \right) \right) \Big|_{[T_{\min}, T_{\max}]}$$

In the example shown in Fig. 3-7 the maximum error occurs at -10 °C:

$$ES = \frac{1.001}{0.993} - 1 = 0.8\%$$

1) normalized to achieve a least-square-fit straight-line that has a value of 1 at 25 °C

2) normalized to achieve a value of 1 at 25 °C

4. Application Notes

4.1. Ambient Temperature

Due to the internal power dissipation, the temperature on the silicon chip (junction temperature T_J) is higher than the temperature outside the package (ambient temperature T_A).

$$T_J = T_A + \Delta T$$

At static conditions and continuous operation, the following equation applies:

$$\Delta T = I_{SUP} * V_{SUP} * R_{thjX}$$

The X represents junction to air or to case.

For worst case calculation, use the max. parameters for I_{SUP} and R_{thjX} , and the max. value for V_{SUP} from the application.

The following example shows the result for junction to air conditions. $V_{SUP} = 5.5$ V, $R_{thja} = 250$ K/W and $I_{DD} = 10$ mA the temperature difference $\Delta T = 13.75$ K.

The junction temperature T_J is specified. The maximum ambient temperature T_{Amax} can be calculated as:

$$T_{Amax} = T_{Jmax} - \Delta T$$

4.2. EMC and ESD

The HAL182x is designed for a stabilized 5 V supply. Interferences and disturbances conducted along the 12 V onboard system (product standard ISO 7637 part 1) are not relevant for these applications.

For applications with disturbances by capacitive or inductive coupling on the supply line or radiated disturbances, the application circuit shown in Fig. 4–1 is recommended. Applications with this arrangement should pass the EMC tests according to the product standards ISO 7637 part 3 (Electrical transient transmission by capacitive or inductive coupling) and part 4 (Radiated disturbances).

4.3. Application Circuit

For EMC protection, it is recommended to connect one ceramic 47 nF capacitor between ground and output voltage pin as well as 100 nF between supply and ground.

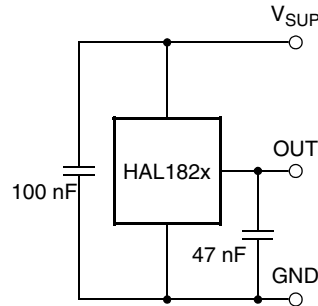

Fig. 4–1: Recommended application circuit

5. Data Sheet History

1. Advance Information: "HAL1821...HAL1823, Linear Hall Effect Sensors Family", July 1, 2009, 000148_001EN. First release of the advance information.
2. Advance Information: "HAL1821...HAL1823, Linear Hall Effect Sensors Family", April 28, 2010, 000148_002EN. Second release of the advance information.
Major changes: Electrical characteristics
3. Data Sheet: "HAL1821...HAL1823, Linear Hall Effect Sensors Family", May 6, 2011, 000157_001EN. First release of the data sheet.