

Data Sheet

HAL[®] 1820

Programmable Linear
Hall Effect Sensor

Copyright, Warranty, and Limitation of Liability

The information and data contained in this document are believed to be accurate and reliable. The software and proprietary information contained therein may be protected by copyright, patent, trademark and/or other intellectual property rights of Micronas. All rights not expressly granted remain reserved by Micronas.

Micronas assumes no liability for errors and gives no warranty representation or guarantee regarding the suitability of its products for any particular purpose due to these specifications.

By this publication, Micronas does not assume responsibility for patent infringements or other rights of third parties which may result from its use. Commercial conditions, product availability and delivery are exclusively subject to the respective order confirmation.

Any information and data which may be provided in the document can and do vary in different applications, and actual performance may vary over time.

All operating parameters must be validated for each customer application by customers' technical experts. Any new issue of this document invalidates previous issues. Micronas reserves the right to review this document and to make changes to the document's content at any time without obligation to notify any person or entity of such revision or changes. For further advice please contact us directly.

Do not use our products in life-supporting systems, aviation and aerospace applications! Unless explicitly agreed to otherwise in writing between the parties, Micronas' products are not designed, intended or authorized for use as components in systems intended for surgical implants into the body, or other applications intended to support or sustain life, or for any other application in which the failure of the product could create a situation where personal injury or death could occur.

No part of this publication may be reproduced, photocopied, stored on a retrieval system or transmitted without the express written consent of Micronas.

Micronas Trademarks

– HAL

Micronas Patents

Choppered Offset Compensation protected by Micronas patents no. US5260614A, US5406202A, EP0525235B1 and EP0548391B1.

Sensor programming with VDD-Modulation protected by Micronas Patent No. EP 0 953 848.

Third-Party Trademarks

All other brand and product names or company names may be trademarks of their respective companies.

Contents

Page	Section	Title
4	1.	Introduction
4	1.1.	Major Applications
4	1.2.	Features
5	1.3.	Marking Code
5	1.4.	Operating Junction Temperature Range (T_J)
5	1.5.	Hall Sensor Package Codes
5	1.6.	Solderability and Welding
5	1.7.	Pin Connections and Short Descriptions
6	2.	Functional Description
6	2.1.	General Function
8	2.2.	Digital Signal Processing and EEPROM
8	2.2.1.	Customer Register I
8	2.2.2.	Customer Register II
9	2.2.3.	Customer register III and IV
10	2.2.4.	Signal Path
10	2.3.	Calibration Procedure
10	2.3.1.	General Procedure
11	3.	Specifications
11	3.1.	Outline Dimensions
16	3.2.	Dimensions of Sensitive Area
16	3.3.	Package Dimensions
16	3.4.	Absolute Maximum Ratings
17	3.4.1.	Storage and Shelf Life
17	3.5.	Recommended Operating Conditions
18	3.6.	Characteristics
19	3.7.	Magnetic Characteristics
21	3.7.1.	Definition of Sensitivity Error ES
22	4.	Application Notes
22	4.1.	Ambient Temperature
22	4.2.	EMC and ESD
22	4.3.	Application Circuit
23	4.4.	Temperature Compensation
24	5.	Programming of the Sensor
24	5.1.	Programming Interface
25	5.2.	Programming Environment and Tools
25	5.3.	Programming Information
26	6.	Data Sheet History

Programmable Linear Hall Effect Sensor

1. Introduction

The HAL 1820 is a new member of the Micronas family of programmable linear Hall-Effect Sensors.

The HAL 1820 is a universal magnetic field sensor with a ratiometric, linear analog output. It is produced in CMOS technology and can be used for magnetic field measurements, current measurements, and detection of mechanical movement. Very accurate angle measurements or distance measurements can also be made. The sensor is very robust and can be used in electrically and mechanically harsh environments. Major characteristics like magnetic field range, sensitivity, offset (output voltage at zero magnetic field) and the temperature coefficients are programmable in a non-volatile memory. The HAL 1820 features a customer data register that enables the customer to store production information (like production serial number) inside each sensor.

The sensor includes a temperature-compensated Hall plate with chopped offset compensation, an A/D converter, digital signal processing, an EEPROM memory with redundancy and lock function for the calibration data, a serial interface for programming the EEPROM, a ratiometric linear output and protection devices. Internal digital signal processing compensates for analog offsets, temperature changes, and mechanical stress, resulting in highly stable performance.

The HAL 1820 is programmable by modulation of the supply voltage. No additional programming pin is needed. The easy programmability allows a 2-point calibration by adjusting the output signal directly to the input signal (like mechanical angle, distance, or current). Individual adjustment of each sensor during the customer's manufacturing process is possible. With this calibration procedure, the tolerances of the sensor, the magnet and the mechanical positioning can be compensated in the final assembly.

In addition, the temperature compensation of the Hall IC can be fit to all common magnetic materials by programming first and second order temperature coefficients of the Hall sensor sensitivity. This enables operation over the full temperature range with high accuracy.

The calculation of the individual sensor characteristics and the programming of the EEPROM memory can easily be done with a PC and the application kit from Micronas.

The sensor is designed for industrial and automotive applications and operates in the junction temperature range from $-40\text{ }^{\circ}\text{C}$ up to $170\text{ }^{\circ}\text{C}$. The HAL 1820 is available in the very small leaded packages TO92UA-1 and TO92UA-2 and in the SMD-package SOT89B-1.

1.1. Major Applications

Due to the sensor's robust characteristics, the HAL 1820 is the optimal system solution for applications such as:

- linear position measurements,
- angle sensors,
- distance measurements,
- magnetic field and current measurement.

1.2. Features

- Ratiometric linear output proportional to the magnetic field
- Various programmable magnetic characteristics with non-volatile memory
- Digital signal processing
- Continuous measurement ranges from $\pm 20\text{ mT}$ to $\pm 160\text{ mT}$
- Customer readable Micronas production information (like lot number, wafer number, etc.)
- Temperature characteristics programmable for matching all common magnetic materials
- Programming via supply voltage modulation
- Lock function and built-in redundancy for EEPROM memory
- Temperature and stress-stable quiescent output voltage
- on-chip temperature compensation
- active offset compensation
- operates from $-40\text{ }^{\circ}\text{C}$ up to $170\text{ }^{\circ}\text{C}$ junction temperature
- operates from 4.5 V up to 5.5 V supply voltage in specification
- operates with static magnetic fields and dynamic magnetic fields up to 2.25 kHz
- overvoltage and reverse-voltage protection at VDD pin
- magnetic characteristics extremely robust against mechanical stress
- short-circuit protected push-pull output
- EMC and ESD optimized design

1.3. Marking Code

The HAL 1820 has a marking on the package surface (branded side). This marking includes the name of the sensor and the temperature range.

Type	Temperature Range	
	A	K
HAL 1820	1820A	1820K

1.4. Operating Junction Temperature Range (T_J)

The Hall sensors from Micronas are specified to the chip temperature (junction temperature T_J).

A: T_J = -40 °C to +170 °C

K: T_J = -40 °C to +140 °C

The relationship between ambient temperature (T_A) and junction temperature is explained in Section 4.1. on page 22.

1.5. Hall Sensor Package Codes

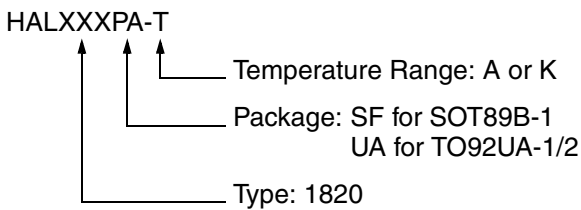

Example: **HAL1820UA-K**

- Type: 1820
- Package: TO92UA-1/2
- Temperature Range: T_J = -40 °C to +140 °C

Hall sensors are available in a wide variety of packaging versions and quantities. For more detailed information, please refer to the brochure: “Hall Sensors: Ordering Codes, Packaging, Handling”.

1.6. Solderability and Welding

Soldering

During soldering reflow processing and manual reworking, a component body temperature of 260 °C should not be exceeded.

Welding

Device terminals should be compatible with laser and resistance welding. Please note that the success of the welding process is subject to different welding parameters which will vary according to the welding technique used. A very close control of the welding parameters is absolutely necessary in order to reach satisfying results. Micronas, therefore, does not give any implied or express warranty as to the ability to weld the component.

1.7. Pin Connections and Short Descriptions

Pin No.	Pin Name	Type	Short Description
1	V _{SUP}	IN	Supply Voltage and Programming Pin
2	GND		Ground
3	OUT	OUT	Push-Pull Output in Application mode

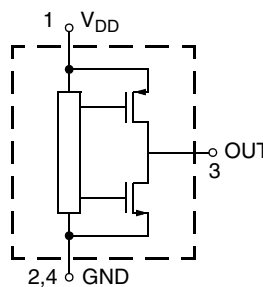

Fig. 1-1: Pin configuration

2. Functional Description

2.1. General Function

The HAL1820 is a monolithic integrated circuit which provides an output voltage proportional to the magnetic flux through the Hall plate and proportional to the supply voltage (ratiometric behavior).

The external magnetic field component perpendicular to the branded side of the package generates a Hall voltage. The Hall IC is sensitive to magnetic north and south polarity. This voltage is converted to a digital value, processed in the Digital Signal Processing Unit (DSP) according to the settings of the EEPROM registers, converted back to an analog voltage by a D/A converter and buffered by a push-pull output transistor stage. The function and the parameter for the DSP are explained in Section 2.2. on page 8. Internal temperature compensation circuitry and the chopped offset compensation enables operation over the full temperature range with minimal degradation in accuracy and offset. The circuitry also rejects offset shifts due to mechanical stress from the package. In addition, the sensor IC is equipped with devices for overvoltage and reverse-voltage protection at supply pin.

A LOCK register disables the programming of the EEPROM memory. The register can not be reset by the customer.

As long as the LOCK register is not set, the output characteristic can be adjusted by programming the EEPROM registers. The IC can be programmed via V_{SUP} line. After detecting a command, the sensor reads or writes the memory and answers with a digital signal on the output pin.

Output/Magnetic Field Polarity

Applying a south-pole magnetic field perpendicular to the branded side of the package will increase the output voltage (for Sensitivity < 0) from the quiescent (offset) voltage towards the supply voltage. A negative magnetic field will decrease the output voltage. The output logic will be inverted for sensitivity >0.

In addition HAL1820 features an internal error detection. The following error modes can be detected:

- Over-/underflow in adder or multiplier
- Over-/underflow in A/D converter
- Overtemperature detection

In case of an error the sensors output will be forced to the lower error band. The error band is defined by VDIAG (see Section 3.6. on page 14).

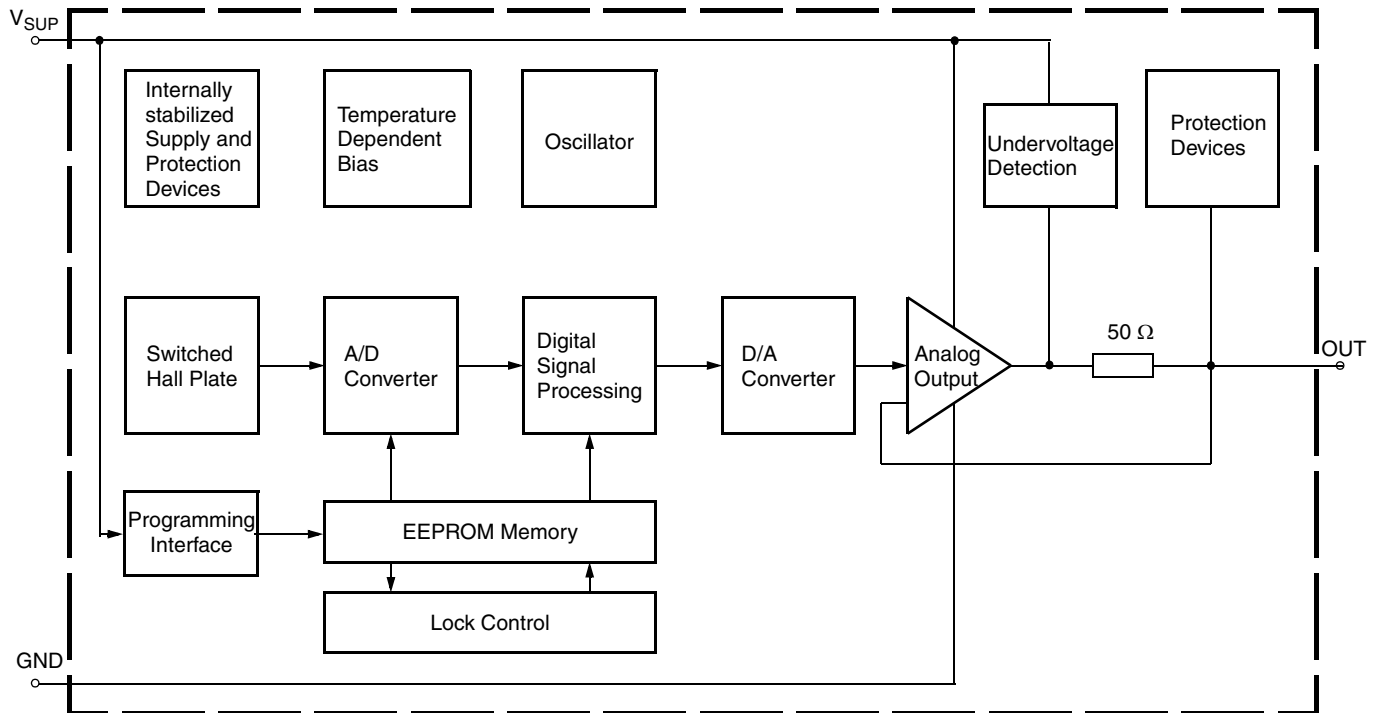

Fig. 2-1: HAL1820 block diagram

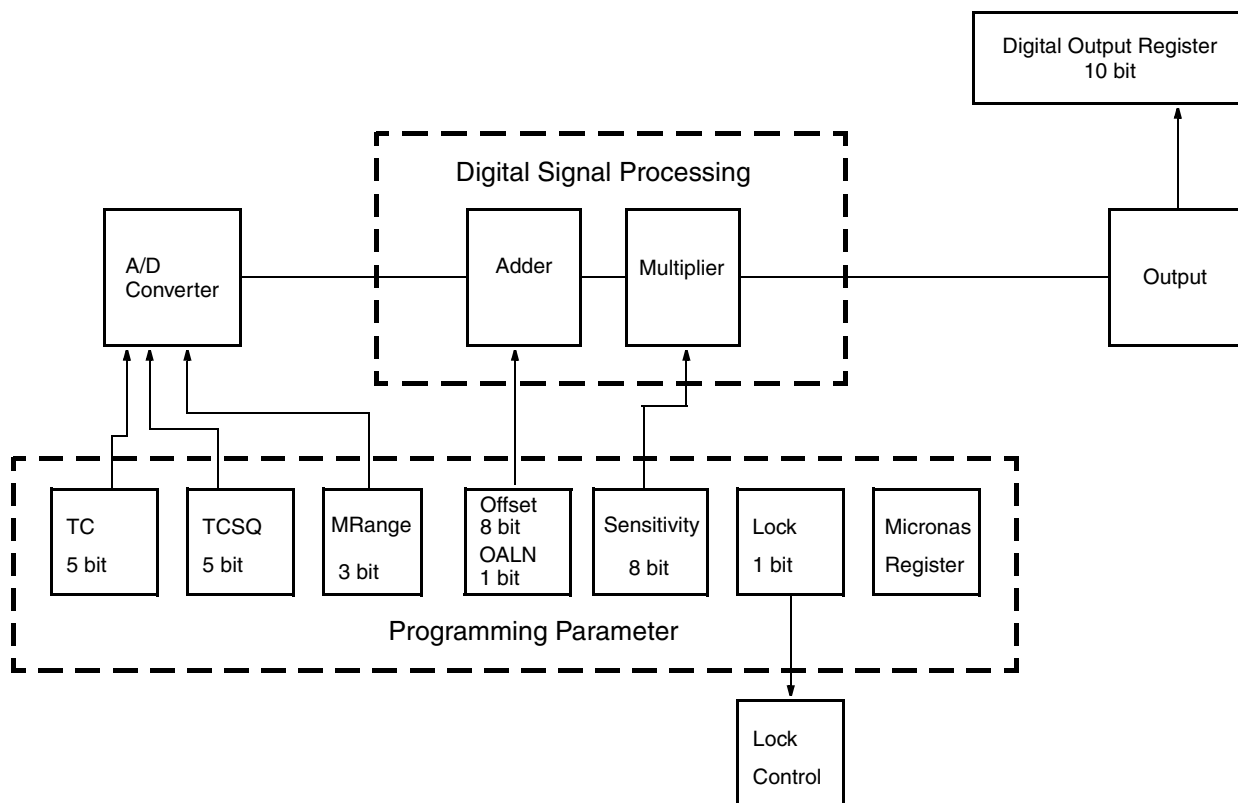

Fig. 2–2: Details of Programming Parameter and Digital Signal Processing

Table 2–1: Cross reference table EEPROM register and sensor parameter

EEPROM-Register	Parameter	Data Bits	Function
customer register I	Sensitivity	8	Magnetic sensitivity
	Offset	8	Magnetic offset
customer register II	LOCKR	1	Customer Lock
	OALN	1	Magnetic Offset Alignment Bit (MSB or LSB aligned)
	TCSQ	5	Quadratic temperature coefficient
	TC	5	Linear temperature coefficient
customer register III	MRANGE	3	Available magnetic ranges
	Micronas Data	16	Micronas production information (read only)
customer register IV	Micronas Data	16	Micronas production information (read only)

2.2. Digital Signal Processing and EEPROM

The DSP is the major part of this sensor and performs the signal conditioning. The parameters for the DSP are stored in the EEPROM registers. The details are shown in Fig. 2-2.

The measurement data can be readout from the DIGITAL OUTPUT register.

DIGITAL OUTPUT

This 16-bit register delivers the actual digital value of the applied magnetic field after the signal processing. This register can only be read out, and it is the basis for the calibration procedure of the sensor in the system environment. Only 10 bits of the register contain valid data. The DIGITAL OUTPUT range is from -512 to 511.

For Sensitivity = 1 the DIGITAL OUTPUT value will increase for negative magnetic fields (north pole) on the branded side of the package (positive DIGITAL OUTPUT values).

Note: During application design, it should be taken into consideration that DIGITAL OUTPUT should not saturate in the operational range of the specific application.

The area in the EEPROM accessible for the customer consists of four so called customer registers with a size of 16 bit each.

2.2.1. Customer Register I

Customer register I contains the bits for magnetic sensitivity (SENSITIVITY) and magnetic offset (OFFSET).

SENSITIVITY

The SENSITIVITY bits define the parameter for the multiplier in the DSP. The Sensitivity is programmable between -2 and 2. The SENSITIVITY bits can be changed in steps of 0.0156. Sensitivity = 1 (@ Offset = 0) corresponds to full-scale of the output signal if the A/D-converter value has reached the full-scale value.

OFFSET

The OFFSET bits define the parameter for the adder in the DSP. Offset defines the output signal without external magnetic field (B = 0 mT).

The customer can decide if the Offset is MSB aligned or LSB aligned. The MSB or LSB alignment is enabled by an additional Offset alignment bit (OALN). In case the OALN bit is 1 the Offset is programmable from -50% up to 50% of V_{DD} . This means that the Offset covers the full-scale range. If the OALN bit is set to zero, then the Offset covers only 1/4 of the full-scale (-12.5% up to 12.5% of V_{DD}). The customer can adjust the Offset symmetrically around 50% of V_{DD} (37.5%... 62.5% of V_{DD}). The OFFSET register can be set with 8-bit resolution.

2.2.2. Customer Register II

Customer register II contains the bits for magnetic range (MRANGE), linear and quadratic temperature coefficients (TC and TCSQ), magnetic offset alignment (OALN) and the customer lock bit.

MRANGE

The MRANGE bits define the magnetic field range of the A/D converter. The following eight magnetic ranges are available.

Table 2-2: MRANGE bit definition

Magnetic Field Range	BIT SETTING
-20 mT...20 mT	0
-40 mT...40 mT	1
-60 mT...60 mT	2
-80 mT...80 mT	3
-100 mT...100 mT	4
-120 mT...120 mT	5
-140 mT...140 mT	6
-160 mT...160 mT	7

TC and TCSQ

The temperature dependence of the magnetic sensitivity can be adapted to different magnetic materials in order to compensate for the change of the magnetic strength with temperature. The adaption is done by programming the TC (Linear Temperature Coefficient) and the TCSQ registers (Quadratic Temperature Coefficient). Thereby, the slope and the curvature of the temperature dependence of the magnetic sensitivity can be matched to the magnet and the sensor assembly. As a result, the output signal characteristic can be fixed over the full temperature range. The sensor can compensate for linear temperature coefficients ranging from about -3100 ppm/K up to 2550 ppm/K and quadratic coefficients from about -7 ppm/K² to 15 ppm/K² (typical range). Min. and max. values for quadratic temperature coefficient depend on linear temperature coefficient. Please refer to Section 4.4. on page 23 for the recommended settings for different linear temperature coefficients.

Magnetic Offset Alignment Bit (OALN)

Please refer to Section 2.2.1. on page 8 (OFFSET).

LOCK

By setting this 1-bit register, all registers will be locked, and the EEPROM content can not be changed anymore. It is still possible to read all register content by sending a read command to the sensor. The LOCK bit is active after the first power-off and power-on sequence after setting the LOCK bit.

Warning: This register cannot be reset!

2.2.3. Customer register III and IV

Customer register III and IV contain 16 bits each. These two registers can be read by the customer and Micronas will use this register to store production information like wafer position, wafer number and production lot number.

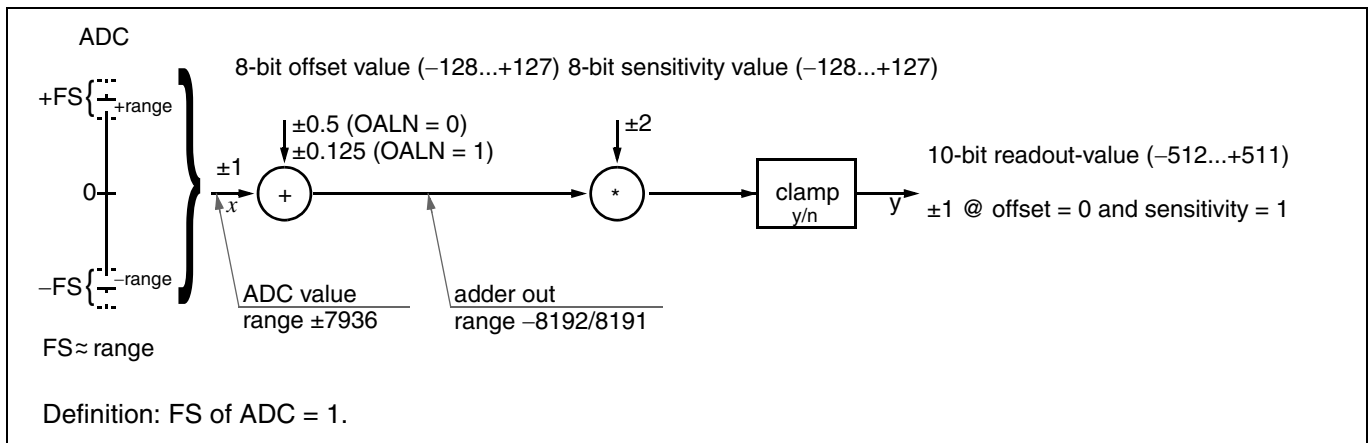

Fig. 2-3: Signal path HAL 1820

2.2.4. Signal Path

Fig. 2-3 shows the signal path and signal processing of HAL1820. The measurement output value y is calculated out of the input signal X with the following equation

$$Y = sensitivity \cdot (X - OFFSET)$$

The parameters offset and sensitivity are two's complement encoded 8-bit values (see Section 2.2.1. on page 8).

2.3. Calibration Procedure

2.3.1. General Procedure

For calibration in the system environment, the application kit from Micronas is recommended. It contains the hardware for the generation of the serial telegram for programming and the corresponding software for the input of the register values.

For the individual calibration of each sensor in the customer application, a two-point adjustment is recommended. Please use Micronas Software Kit for the calibration.

Locking the Sensor

The last step is activating the LOCK function by setting the LOCK bit. Please note that the LOCK function becomes effective after power-down and power-up of the Hall IC. The sensors EEPROM is then locked and its content can not be changed anymore. The sensor still answers to read commands on the supply line.

Warning: This register cannot be reset!

3. Specifications

3.1. Outline Dimensions

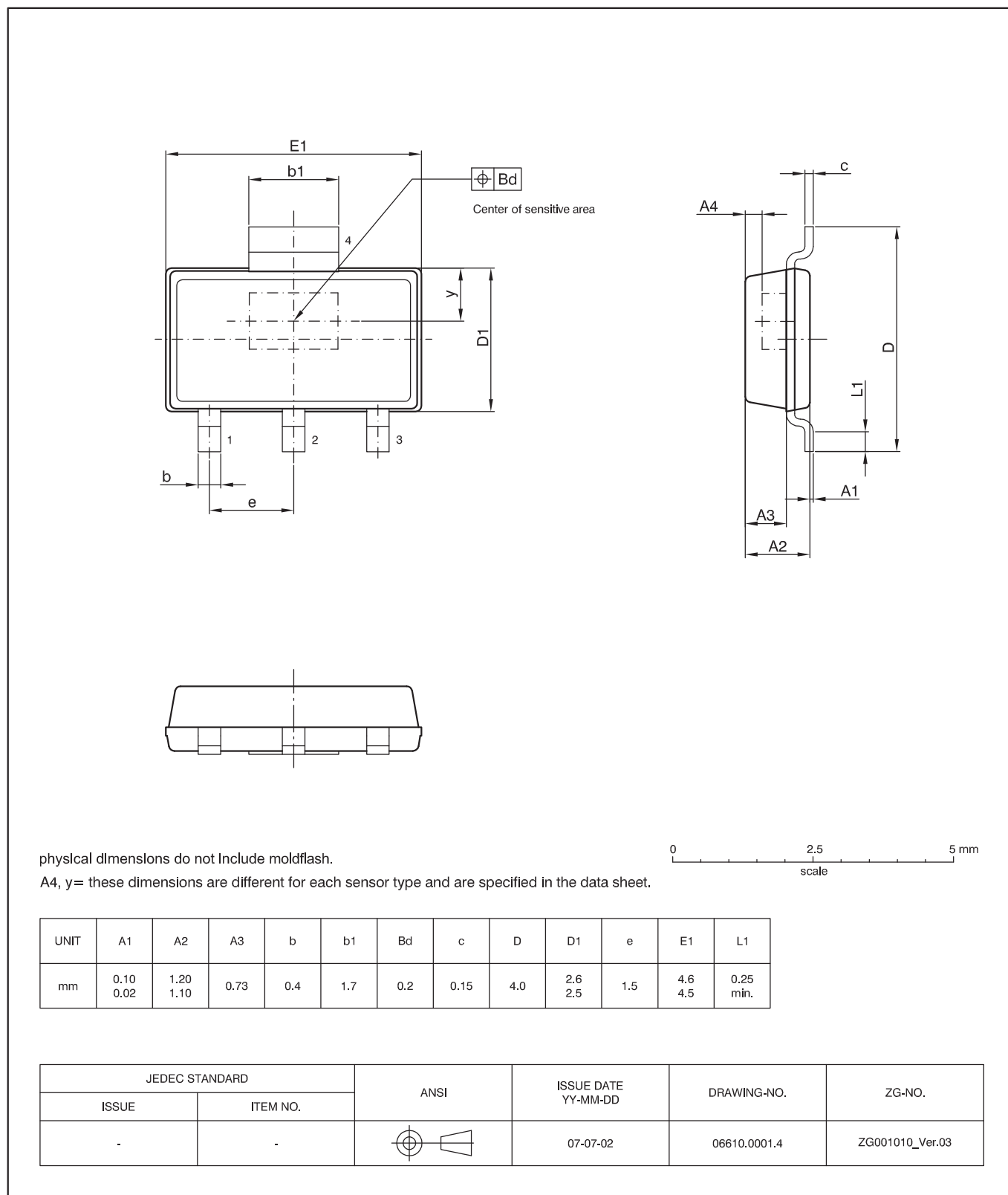

Fig. 3-1:
SOT89B-1: Plastic Small Outline Transistor package, 4 leads
 Ordering code: SF
 Weight approximately 0.034 g

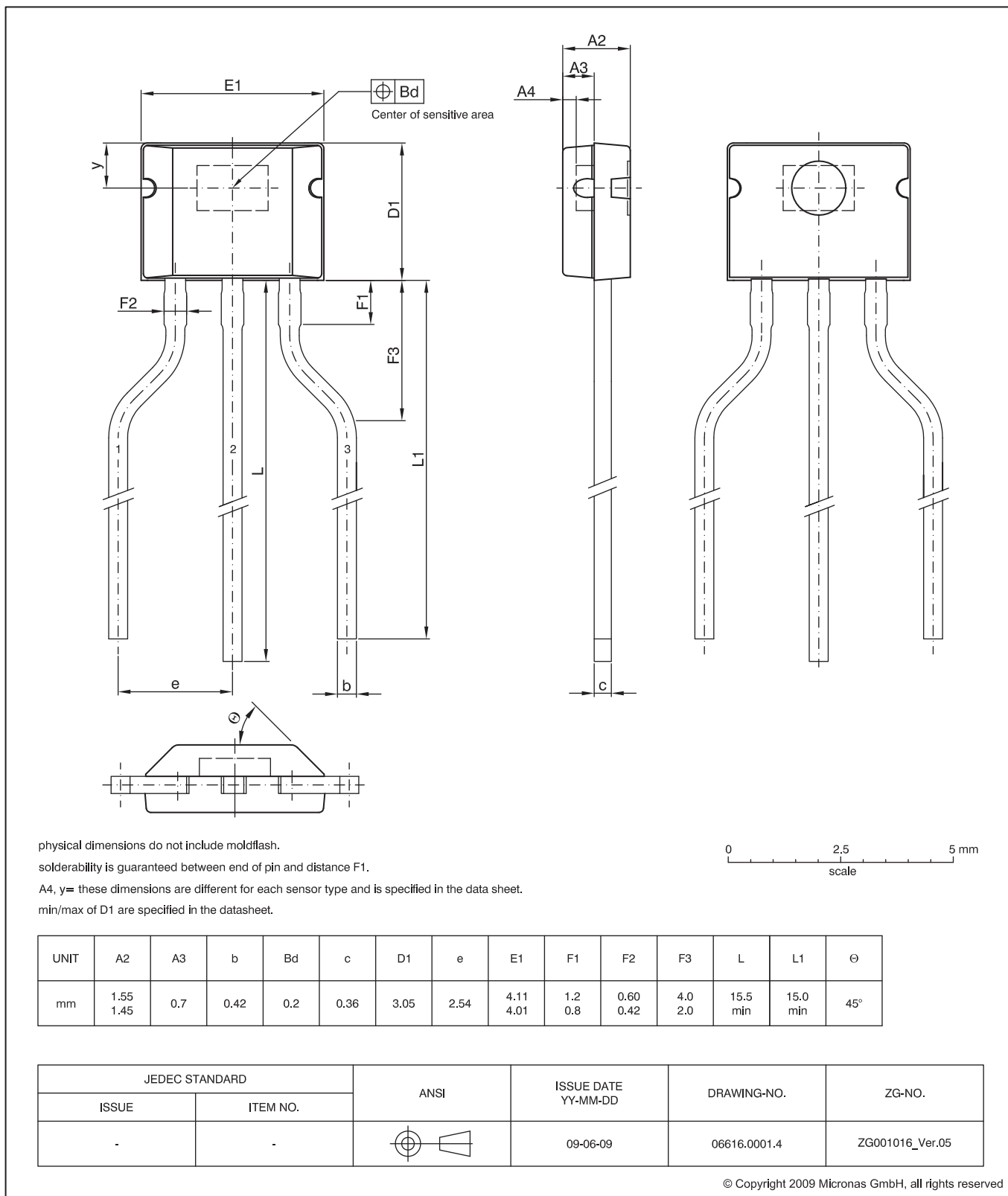

Fig. 3-2:
TO92UA-1: Plastic Transistor Standard UA package, 3 leads, spread
 Weight approximately 0.106 g

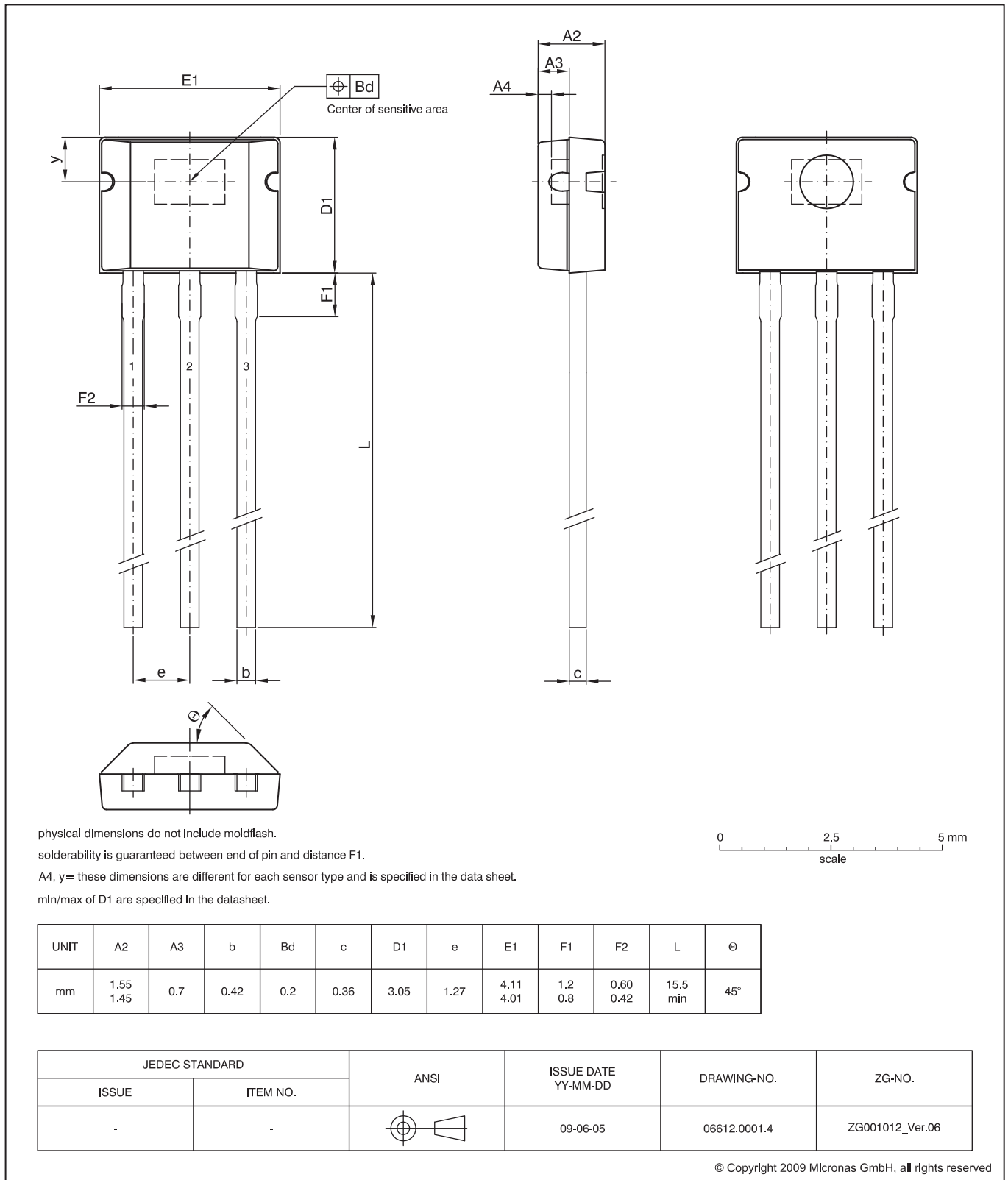

Fig. 3-3:
TO92UA-2: Plastic Transistor Standard UA package, 3 leads, not spread
Weight approximately 0.106 g

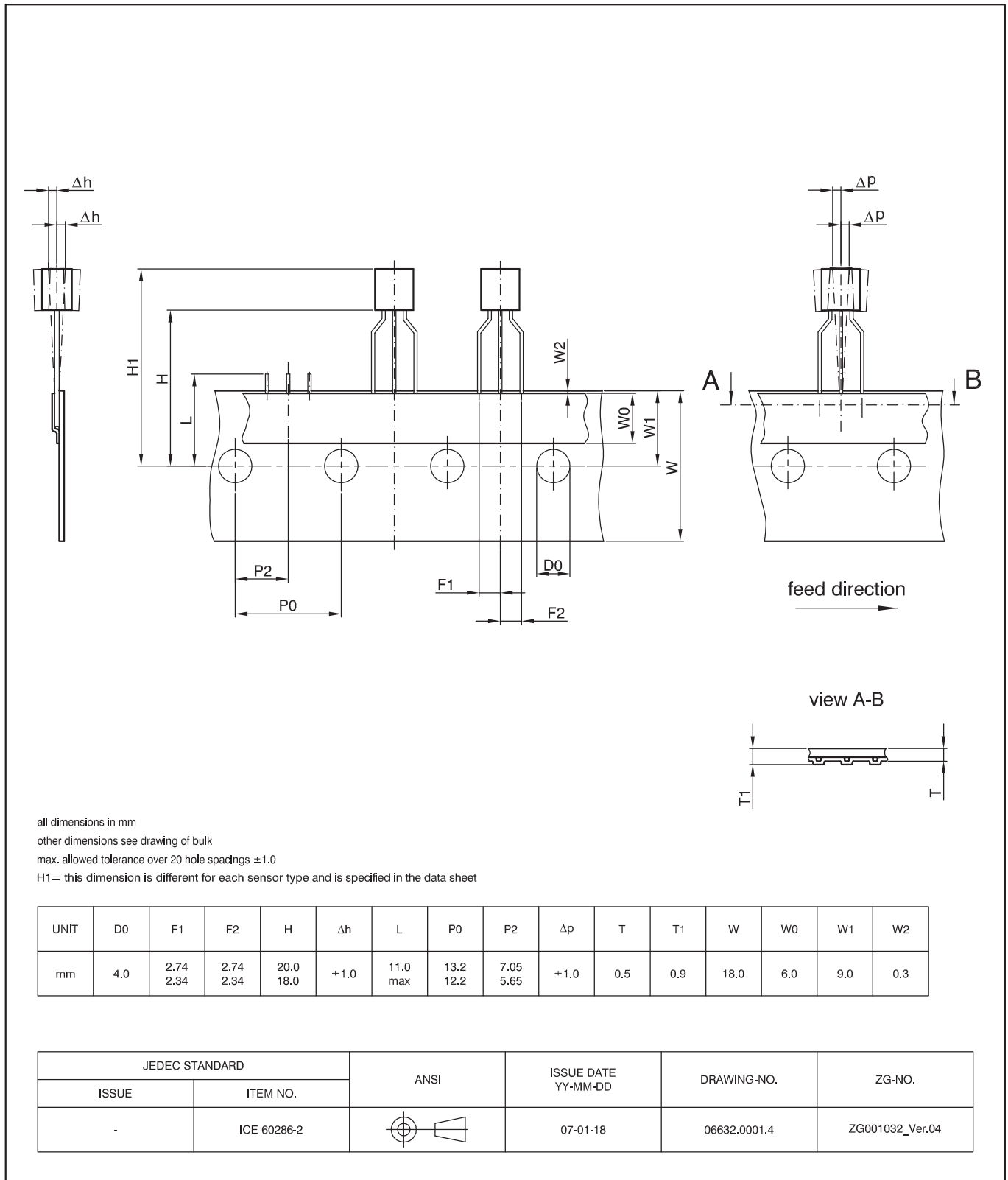

Fig. 3-4:
T092UA/UT-1: Dimensions ammopack inline, spread

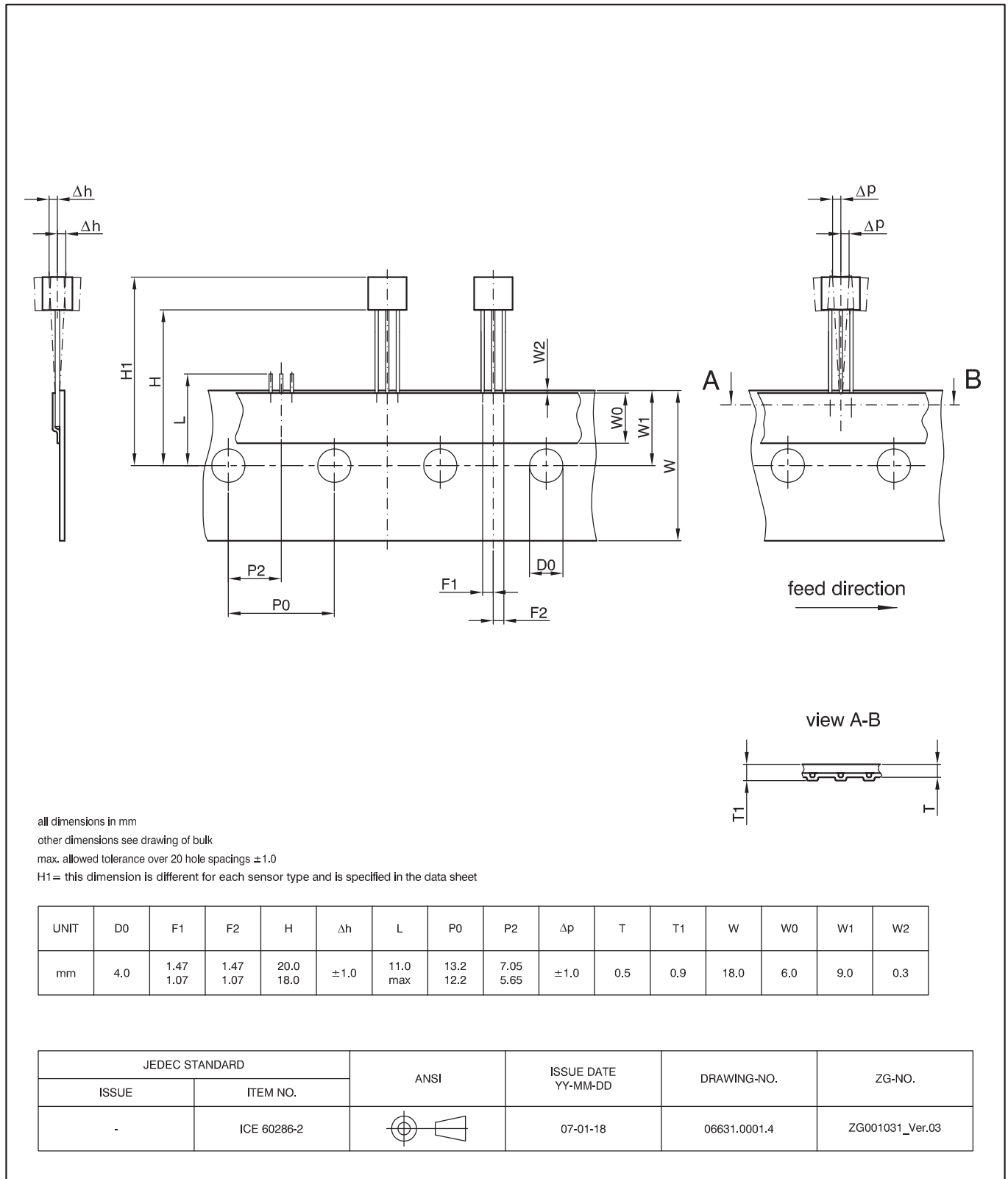

Fig. 3-5:
T092UA/UT-2: Dimensions ammpack inline, not spread

3.2. Dimensions of Sensitive Area

0.2 mm x 0.1 mm

3.3. Package Dimensions

	TO92UA-1/-2	SOT89B-1
y	1.0 mm nominal	0.95 mm nominal
A4	0.4 mm nominal	0.4 mm nominal
D1	3.05 ± 0.05 mm	2.55 ± 0.05 mm
H1	min. 21 mm max. 23.1 mm	not applicable

3.4. Absolute Maximum Ratings

Stresses beyond those listed in the “Absolute Maximum Ratings” may cause permanent damage to the device. This is a stress rating only. Functional operation of the device at these conditions is not implied. Exposure to absolute maximum rating conditions for extended periods will affect device reliability.

This device contains circuitry to protect the inputs and outputs against damage due to high static voltages or electric fields; however, it is advised that normal precautions be taken to avoid application of any voltage higher than absolute maximum-rated voltages to this circuit.

All voltages listed are referenced to ground (GND).

Symbol	Parameter	Pin No.	Min.	Max.	Unit	Condition
V _{SUP}	Supply Voltage	1	-8.5	8.5	V	t < 96 h, not additive
			-14.4 -15	14.4 16	V	t < 10 min. ¹⁾ t < 1 min. ¹⁾ not additive
V _{OUT}	Output Voltage ¹⁾	3	-0.5 ²⁾ -0.5 ²⁾ -0.5 ²⁾	8.5 14.4 16	V	t < 96 h t < 10 min. t < 1 min. not additive
V _{OUT} -V _{SUP}	Excess of Output Voltage over Supply Voltage	1,3	-	0.5	V	
I _{OUT}	Continuous Output Current	3	-5	5	mA	
t _{Sh}	Output Short Circuit Duration	3	-	10	min	
T _J	Junction Temperature Range		-40	190 ³⁾	°C	not additive
VESD	ESD Protection ⁴⁾	1,2,3	-4.0	4.0	kV	
¹⁾ as long as T _{Jmax} is not exceeded ²⁾ internal protection resistor = 50 Ω ³⁾ for 96h - Please contact Micronas for other temperature requirements ⁴⁾ AEC-Q100-002 (100 pF and 1.5 kΩ)						

3.4.1. Storage and Shelf Life

The permissible storage time (shelf life) of the sensors is unlimited, provided the sensors are stored at a maximum of 30 °C and a maximum of 85% relative humidity. At these conditions, no Dry Pack is required.

Solderability is guaranteed for one year from the date code on the package.

3.5. Recommended Operating Conditions

Functional operation of the device beyond those indicated in the “Recommended Operating Conditions/Characteristics” is not implied and may result in unpredictable behavior of the device and may reduce reliability and lifetime.

All voltages listed are referenced to ground (GND).

Symbol	Parameter	Pin No.	Min.	Typ.	Max.	Unit	Remarks
V _{SUP}	Supply Voltage	1	4.5	5	5.5	V	
I _{OUT}	Continuous Output Current	3	-1	-	1	mA	
R _L	Load Resistor	3	5.5	10	-	kΩ	
C _L	Load Capacitance	3	0.33	10	47	nF	
N _{PRG}	Number of EEPROM Programming Cycles	-	-	-	100	-	0 °C < T _{amb} < 55 °C
T _J	Junction Operating Temperature ¹⁾	-	-40 -40 -40	- - -	125 150 170	°C °C °C	for 8000 h (not additive) for 2000 h (not additive) < 1000 h (not additive)
¹⁾ Depends on the temperature profile of the application. Please contact Micronas for life time calculations.							

3.6. Characteristics

at $T_J = -40\text{ °C}$ to $+170\text{ °C}$ (for temperature type A), $V_{SUP} = 4.5\text{ V}$ to 5.5 V , $GND = 0\text{ V}$, after programming the sensor and locking the EEPROM,

at Recommended Operation Conditions if not otherwise specified in the column “Conditions”.

Typical Characteristics for $T_J = 25\text{ °C}$ and $V_{SUP} = 5\text{ V}$.

For all other temperature ranges this table is also valid, but only in the junction temperature range defined by the temperature grade (Example: For K-Type this table is limited to $T_J = -40\text{ °C}$ to $+140\text{ °C}$).

Symbol	Parameter	Pin No.	Min.	Typ.	Max.	Unit	Conditions
I_{SUP}	Supply Current over Temperature Range	1	–	7	10	mA	
	Resolution	3	–	10	–	Bit	
INL	Non-Linearity of Output Voltage over Temperature	3	–1.0	0	1.0	%	% of supply voltage ¹⁾
E_R	Ratiometric Error of Output over Temperature (Error in V_{OUT} / V_{SUP})	3	–1.0	0	1.0	%	
V_{OUTH}	Output High Voltage	3	4.7	4.9	–	V	$V_{SUP} = 5\text{ V}$, $I_{OUT} = +/- 1\text{ mA}^2)$
V_{OUTL}	Output Low Voltage	3	–	0.1	0.3	V	$V_{SUP} = 5\text{ V}$, $I_{OUT} = +/- 1\text{ mA}^2)$
$t_{r(O)}$	Response Time of Output ³⁾	3	–	0.5	1	ms	$C_L = 10\text{ nF}$, time from 10% to 90% of final output voltage for a step like signal B_{step} from 0 mT to B_{max}
t_{POD}	Power-Up Time (Time to reach stabilized Output Voltage) ³⁾	–	–	1	1.5	ms	$C_L = 10\text{ nF}$, 90% of V_{OUT}
BW	Small Signal Bandwidth (–3 dB) ³⁾	3	2.25	2.5	–	kHz	$B_{AC} < 10\text{ mT}$
V_{OUTn}	Output RMS Noise ³⁾	3	–	2.6	5	mV	$B = 5\%$ to 95% of B_{max}
R_{OUT}	Output Resistance over Recommended Operating Range ³⁾	3	–	60	–	Ω	$V_{OUTLmax} \leq V_{OUT} \leq V_{OUTHmin}$
V_{PORLH}	Power-On Reset Level from V_{SUPLow} to $V_{SUPHigh}$	1	3.9	4.35	4.5	V	
V_{PORHL}	Power-On Reset Level from $V_{SUPHigh}$ to V_{SUPLow}	1	3.8	4.2	4.4	V	
V_{PORHYS}	Power-On Reset Hysteresis	1	0.1	0.175	0.3	V	
V_{DIAG}	Output Voltage in case of Error Detection	3	0	–	300	mV	
TO92UA Package							
R_{thja}	Thermal Resistance junction to air	–	–	–	250	K/W	Measured with a 1s0p board
R_{thjc}	junction to case	–	–	–	70	K/W	
SOT89B Package							
R_{thja}	Thermal Resistance junction to air	–	–	–	210	K/W	Measured with a 1s0p board 30 mm x 10 mm x 1.5 mm, pad size (see Fig. 3–6)
R_{thjc}	junction to case	–	–	–	60	K/W	
¹⁾ If more than 50% of the selected magnetic field range are used and V_{OUT} is between 0.3 V and 4.7 V ²⁾ Linear output range ³⁾ Guaranteed by design							

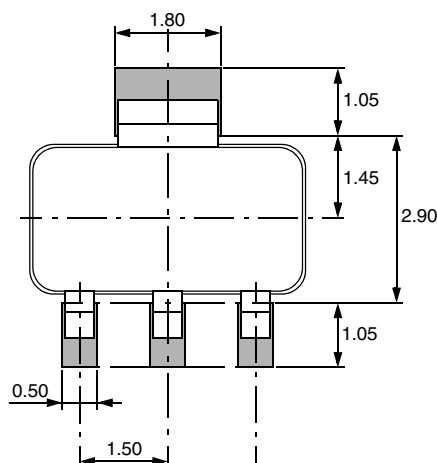

Fig. 3-6: Recommended footprint SOT89B-1, Dimensions in mm.
 All dimensions are for reference only. The pad size may vary depending on the requirements of the soldering process.

3.7. Magnetic Characteristics

at Recommended Operating Conditions if not otherwise specified in the column 'Test Conditions',
 $T_J = -40\text{ }^\circ\text{C}$ to $+170\text{ }^\circ\text{C}$ (for temperature type A), $V_{SUP} = 4.5\text{ V}$ to 5.5 V , after programming the sensor and locking the EEPROM.

Typical Characteristics for $T_A = 25\text{ }^\circ\text{C}$ and $V_{SUP} = 5\text{ V}$.

For all other temperature ranges this table is also valid, but only in the junction temperature range defined by the temperature grade (Example: For K-Type this table is limited to $T_J = -40\text{ }^\circ\text{C}$ to $+140\text{ }^\circ\text{C}$).

Symbol	Parameter	Pin No.	Values			Unit	Test Conditions
			Min.	Typ.	Max.		
RANGE _{ABS}	Absolute Magnetic Range of A/D Converter over temperature	–	80	100	120	%	% of nominal RANGE Nominal RANGE programmable from 20 mT up to 160 mT
RANGE	Magnetic field range	–	± 20	± 80	± 160	mT	
ES	Sensitivity Error over Temperature Range	3	–6	0	6	%	Part to part variation for certain combinations of TC and TCSQ (see Section 3.7.1.)
ΔSens	Sensitivity Drift (beside temperature drift) ¹⁾		–	±2	–	%	$T_J = 25\text{ }^\circ\text{C}$; after temperature cycling and over life time
B _{OFFSET}	Magnetic offset	3	–2	0	2	mT	$B = 0\text{ mT}$, $T_A = 25\text{ }^\circ\text{C}$
ΔB _{OFFSET}	Magnetic offset drift over Temperature Range $B_{OFFSET}(T) - B_{OFFSET}(25\text{ }^\circ\text{C})$	3	–300	0	300	μT	$B = 0\text{ mT}$, RANGE = 20 mT, Sens = 100 mV/mT
B _{Hysteresis}	Magnetic Hysteresis ¹⁾	3	–20	0	20	μT	Range = ±40 mT

¹⁾ Guaranteed by design

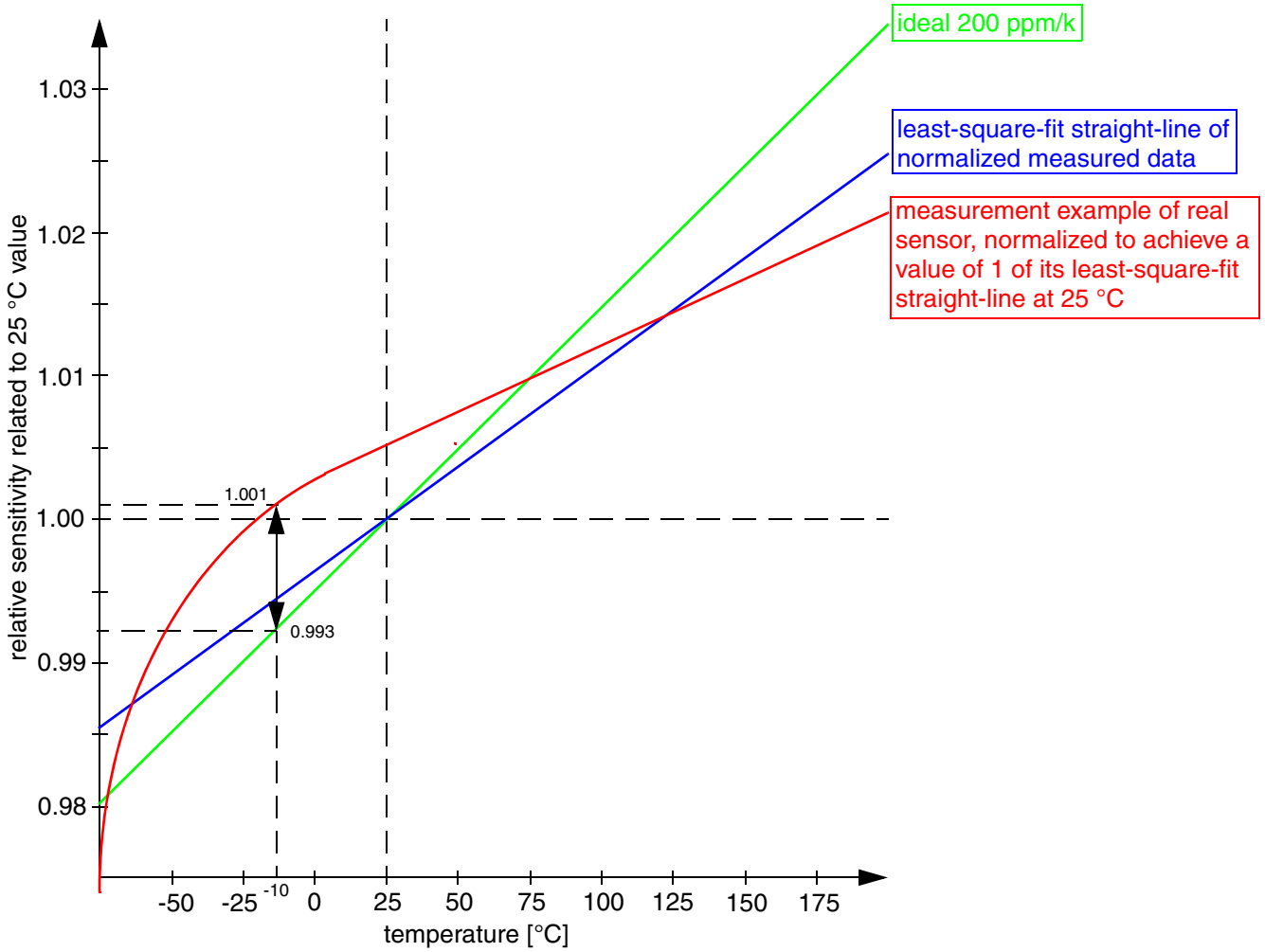

Fig. 3-7: Definition of Sensitivity Error ES.

3.7.1. Definition of Sensitivity Error ES

ES is the maximum of the absolute value of 1 minus the quotient of the normalized measured value¹⁾ over the normalized ideal linear²⁾ value:

$$ES = \max\left(\text{abs}\left(\frac{\text{meas}}{\text{ideal}} - 1\right)\right) \Bigg|_{[T_{\min}, T_{\max}]}$$

In the example shown in Fig. 3–7 the maximum error occurs at –10 °C:

$$ES = \frac{1.001}{0.993} - 1 = 0.8\%$$

1) normalized to achieve a least-square-fit straight-line that has a value of 1 at 25 °C

2) normalized to achieve a value of 1 at 25 °C

4. Application Notes

4.1. Ambient Temperature

Due to the internal power dissipation, the temperature on the silicon chip (junction temperature T_J) is higher than the temperature outside the package (ambient temperature T_A).

$$T_J = T_A + \Delta T$$

At static conditions and continuous operation, the following equation applies:

$$\Delta T = I_{SUP} * V_{SUP} * R_{thjX}$$

The X represents junction to air or to case.

For worst case calculation, use the max. parameters for I_{SUP} and R_{thjX} , and the max. value for V_{SUP} from the application.

The following example shows the result for junction to air conditions. $V_{SUP} = 5.5$ V, $R_{thja} = 250$ K/W and $I_{SUP} = 10$ mA the temperature difference $\Delta T = 13.75$ K.

The junction temperature T_J is specified. The maximum ambient temperature T_{Amax} can be calculated as:

$$T_{Amax} = T_{Jmax} - \Delta T$$

4.2. EMC and ESD

The HAL1820 is designed for a stabilized 5 V supply. Interferences and disturbances conducted along the 12 V onboard system (product standard ISO 7637 part 1) are not relevant for these applications.

For applications with disturbances by capacitive or inductive coupling on the supply line or radiated disturbances, the application circuit shown in Fig. 4–1 is recommended. Applications with this arrangement should pass the EMC tests according to the product standards ISO 7637 part 3 (Electrical transient transmission by capacitive or inductive coupling) and part 4 (Radiated disturbances).

4.3. Application Circuit

For EMC protection, it is recommended to connect one ceramic 47 nF capacitor between ground and output voltage pin as well as 100 nF between supply and ground.

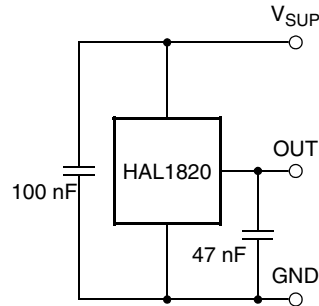

Fig. 4–1: Recommended application circuit

4.4. Temperature Compensation

The relationship between the temperature coefficient of the magnet and the corresponding TC and TCSQ codes for linear compensation is given in the following table. In addition to the linear change of the magnetic field with temperature, the curvature can be adjusted as well. For this purpose, other TC and TCSQ combinations are required which are not shown in the table. Please contact Micronas for more detailed information on this higher order temperature compensation.

Temperature Coefficient of Magnet (ppm/K)	TC	TCSQ
2100	8	0
1800	10	-3
1500	12	-4
1200	14	-5
900	16	-6
500	18	-6
150	20	-6
0	21	-5
-300	22	-5
-500	23	-4
-750	24	-4
-1000	25	-2
-1500	27	0
-2100	29	5
-2700	31	5

Note: Micronas recommends to use the HAL1820 Programming Environment to find optimal settings for temperature coefficients. Please contact Micronas for more detailed information.

5. Programming of the Sensor

HAL1820 features two different customer modes. In **Application Mode** the sensor provides a ratiometric analog output voltage. In **Programming Mode** it is possible to change the register settings of the sensor.

After power-up the sensor is always operating in the **Programming Mode** (default after delivery from Micronas and as long as the sensor is not locked). It is switched to the **Application Mode** by setting a certain volatile bit in the memory of the sensor or by locking the sensor.

5.1. Programming Interface

In Programming Mode the sensor is addressed by modulating a serial telegram on the sensors supply voltage. The sensor answers with a modulation of the output voltage.

A logical “0” is coded as no level change within the bit time. A logical “1” is coded as a level change of typically 50% of the bit time. After each bit, a level change occurs (see Fig. 5–1).

The serial telegram is used to transmit the EEPROM content, error codes and digital values of the magnetic field from and to the sensor.

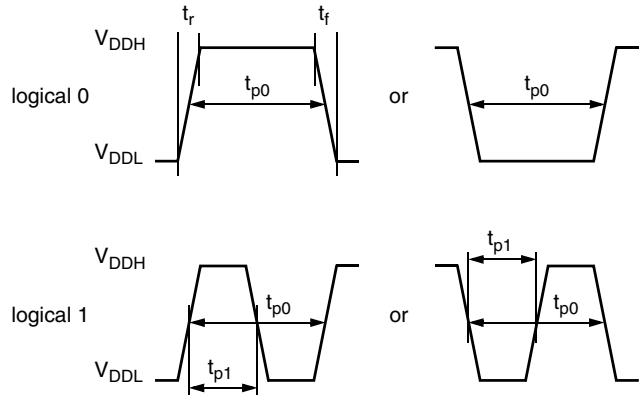

Fig. 5–1: Definition of logical 0 and 1 bit

A description of the communication protocol and the programming of the sensor is available in a separate document (Application Note Programming HAL1820).

Table 5–1: Telegram parameters (All voltages are referenced to GND.)

Symbol	Parameter	Pin No.	Limit Values			Unit	Test Conditions
			Min.	Typ.	Max.		
V _{SUPL}	Supply Voltage for Low Level during Programming through Sensor V _{SUP} Pin	1	5.8	6.3	6.6	V	
V _{SUPH}	Supply Voltage for High Level during Programming through Sensor V _{SUP} Pin	1	6.8	7.3	7.8	V	
V _{SUPProgram}	V _{SUP} Voltage for EEPROM programming (after PROG and ERASE)	1	5.7	5.85	6.0	V	
t _{p0}	Bit time if command send to the sensor	1	–	1024	–	µs	
t _{pOUT}	Bit time for sensor answer	3	–	1024	–	µs	

5.2. Programming Environment and Tools

For the programming of HAL1820 during product development and also for production purposes a programming tool including hardware and software is available on request. It is recommended to use the Micronas tool kit in order to ease the product development. The details of programming sequences are also available on request.

5.3. Programming Information

For production and qualification tests, it is mandatory to set the LOCK bit after final adjustment and programming of HAL1820. The LOCK function is active after the next power-up of the sensor.

The success of the LOCK process should be checked by reading the status of the LOCK bit after locking and/or by an analog check of the sensors output signal.

HAL1820 features a diagnostic register to check the success and quality of the programming process. It is mandatory to check that all bits of the DIAGN register are 0 after the programming of the sensor. More details can be found in the application note "HAL1820 Programming Guide".

Electrostatic Discharges (ESD) may disturb the programming pulses. Please take precautions against ESD.

6. Data Sheet History

1. Advance Information: "HAL 1820, Programmable Linear Hall Effect Sensor", June 30, 2009, AI000149_001EN. First release of the advance information.
2. Advance Information: "HAL 1820, Programmable Linear Hall Effect Sensor", April 28, 2010, AI000149_002. Second release of the advance information.
Major Changes:
 - Reset levels added
 - TC/TCSQ table added
 - Update of magnetic parameters
3. Data Sheet: "HAL 1820 Programmable Linear Hall Effect Sensor", April 28, 2011, DSH000158_001EN. First release of the data sheet.