

Data Sheet

HAL[®] 700, HAL[®] 740

Dual Hall-Effect Sensors
with Independent Outputs

Copyright, Warranty, and Limitation of Liability

The information and data contained in this document are believed to be accurate and reliable. The software and proprietary information contained therein may be protected by copyright, patent, trademark and/or other intellectual property rights of Micronas. All rights not expressly granted remain reserved by Micronas.

Micronas assumes no liability for errors and gives no warranty representation or guarantee regarding the suitability of its products for any particular purpose due to these specifications.

By this publication, Micronas does not assume responsibility for patent infringements or other rights of third parties which may result from its use. Commercial conditions, product availability and delivery are exclusively subject to the respective order confirmation.

Any information and data which may be provided in the document can and do vary in different applications, and actual performance may vary over time.

All operating parameters must be validated for each customer application by customers' technical experts. Any new issue of this document invalidates previous issues. Micronas reserves the right to review this document and to make changes to the document's content at any time without obligation to notify any person or entity of such revision or changes. For further advice please contact us directly.

Do not use our products in life-supporting systems, aviation and aerospace applications! Unless explicitly agreed to otherwise in writing between the parties, Micronas' products are not designed, intended or authorized for use as components in systems intended for surgical implants into the body, or other applications intended to support or sustain life, or for any other application in which the failure of the product could create a situation where personal injury or death could occur.

No part of this publication may be reproduced, photocopied, stored on a retrieval system or transmitted without the express written consent of Micronas.

Micronas Trademarks

– HAL

Micronas Patents

Choppered Offset Compensation protected by Micronas patents no. US5260614, US5406202, EP0525235 and EP0548391.

Third-Party Trademarks

All other brand and product names or company names may be trademarks of their respective companies.

Contents

Page	Section	Title
4	1.	Introduction
4	1.1.	Features
4	1.2.	Family Overview
5	1.3.	Marking Code
5	1.4.	Operating Junction Temperature Range
5	1.5.	Hall Sensor Package Codes
5	1.6.	Solderability and Welding
5	1.7.	Pin Connections
6	2.	Functional Description
9	3.	Specifications
9	3.1.	Outline Dimensions
10	3.2.	Dimensions of Sensitive Area
10	3.3.	Positions of Sensitive Areas
10	3.4.	Absolute Maximum Ratings
10	3.4.1.	Storage and Shelf Life
11	3.5.	Recommended Operating Conditions
12	3.6.	Characteristics
16	4.	Type Description
16	4.1.	HAL700
18	4.2.	HAL740
20	5.	Application Notes
20	5.1.	Ambient Temperature
20	5.2.	Extended Operating Conditions
20	5.3.	Start-up Behavior
20	5.4.	EMC and ESD
22	6.	Data Sheet History

Dual Hall-Effect Sensors with Independent Outputs

Release Note: Revision bars indicate significant changes to the previous edition.

1. Introduction

The HAL700 and the HAL740 are monolithic CMOS Hall-effect sensors consisting of two independent switches controlling two independent open-drain outputs. The Hall plates of the two switches are spaced 2.35 mm apart.

The devices include temperature compensation and active offset compensation. These features provide excellent stability and matching of the switching points in the presence of mechanical stress over the whole temperature and supply voltage range.

The sensors are designed for industrial and automotive applications and operate with supply voltages from 3.8 V to 24 V in the ambient temperature range from -40 °C up to 125 °C.

The HAL700 and the HAL740 are available in the SMD-package SOT89B-2.

1.1. Features

- two independent Hall-switches
- distance of Hall plates: 2.35 mm
- switching offset compensation at typically 150 kHz
- operation from 3.8 V to 24 V supply voltage
- operation with static and dynamic magnetic fields up to 10 kHz
- overvoltage protection at all pins
- reverse-voltage protection at V_{DD} -pin
- robustness of magnetic characteristics against mechanical stress
- short-circuit protected open-drain outputs by thermal shut down
- constant switching points over a wide supply voltage range
- EMC corresponding to ISO 7637

1.2. Family Overview

The types differ according to the switching behavior of the magnetic switching points at the both Hall plates S1 and S2.

Type	Switching Behavior	See Page
HAL700	S1: latching S2: latching	16
HAL740	S1: unipolar north sensitive S2: unipolar south sensitive	18

Latching Sensors:

The output turns low with the magnetic south pole on the branded side of the package. The output maintains its previous state if the magnetic field is removed. For changing the output state, the opposite magnetic field polarity must be applied.

Unipolar Sensors:

In case of a south-sensitive switch, the output turns low with the magnetic south pole on the branded side of the package and turns high if the magnetic field is removed. The switch does not respond to the magnetic north pole on the branded side.

In case of a north-sensitive switch, the output turns low with the magnetic north pole on the branded side of the package and turns high if the magnetic field is removed. The switch does not respond to the magnetic south pole on the branded side.

1.3. Marking Code

All Hall sensors have a marking on the package surface (branded side). This marking includes the name of the sensor and the temperature range.

Type	Temperature Range	
	K	E
HAL700	700K	700E
HAL740	740K	740E

1.4. Operating Junction Temperature Range

The Hall sensors from Micronas are specified to the chip temperature (junction temperature T_J).

K: $T_J = -40\text{ °C to }+140\text{ °C}$

E: $T_J = -40\text{ °C to }+100\text{ °C}$

Note: Due to power dissipation, there is a difference between the ambient temperature (T_A) and junction temperature. Please refer to section 5.1. on page 20 for details.

1.5. Hall Sensor Package Codes

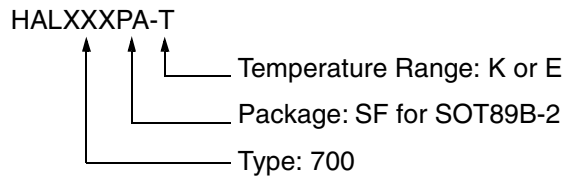

Example: **HAL700SF-K**

- Type: 700
- Package: SOT89B-2
- Temperature Range: $T_J = -40\text{ °C to }+140\text{ °C}$

Hall sensors are available in a wide variety of packaging versions and quantities. For more detailed information, please refer to the brochure: “Hall Sensors: Ordering Codes, Packaging, Handling”.

1.6. Solderability and Welding

Soldering

During soldering reflow processing and manual reworking, a component body temperature of 260 °C should not be exceeded.

Welding

Device terminals should be compatible with laser and resistance welding. Please note that the success of the welding process is subject to different welding parameters which will vary according to the welding technique used. A very close control of the welding parameters is absolutely necessary in order to reach satisfying results. Micronas, therefore, does not give any implied or express warranty as to the ability to weld the component.

1.7. Pin Connections

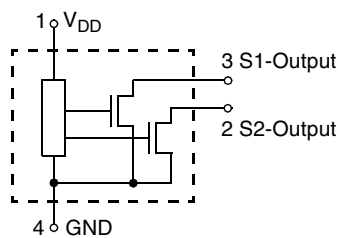

Fig. 1–1: Pin configuration

2. Functional Description

The HAL700 and the HAL740 are monolithic integrated circuits with two independent subblocks each consisting of a Hall plate and the corresponding comparator. Each subblock independently switches the comparator output in response to the magnetic field at the location of the corresponding sensitive area. If a magnetic field with flux lines perpendicular to the sensitive area is present, the biased Hall plate generates a Hall voltage proportional to this field. The Hall voltage is compared with the actual threshold level in the comparator. The subblocks are designed to have closely matched switching points. The output of comparator 1 attached to S1 controls the open drain output at Pin 3. Pin 2 is set according to the state of comparator 2 connected to S2.

The temperature-dependent bias – common to both subblocks – increases the supply voltage of the Hall plates and adjusts the switching points to the decreasing induction of magnets at higher temperatures. If the magnetic field exceeds the threshold levels, the comparator switches to the appropriate state. The built-in hysteresis prevents oscillations of the outputs.

The magnetic offset caused by mechanical stress is compensated for by use of “switching offset compensation techniques”. Therefore, an internal oscillator provides a two-phase clock to both subblocks. For each subblock, the Hall voltage is sampled at the end of the first phase. At the end of the second phase, both sampled and actual Hall voltages are averaged and compared with the actual switching point.

Shunt protection devices clamp voltage peaks at the output pins and V_{DD} -pin together with external series resistors. Reverse current is limited at the V_{DD} -pin by an internal series resistor up to -15 V . No external reverse protection diode is needed at the V_{DD} -pin for reverse voltages ranging from 0 V to -15 V .

Fig. 2–2 and Fig. 2–3 on page 7 show how the output signals are generated by the HAL700 and the HAL740. The magnetic flux density at the locations of the two Hall plates is shown by the two sinusoidal curves at the top of each diagram. The magnetic switching points are depicted as dashed lines for each Hall plate separately.

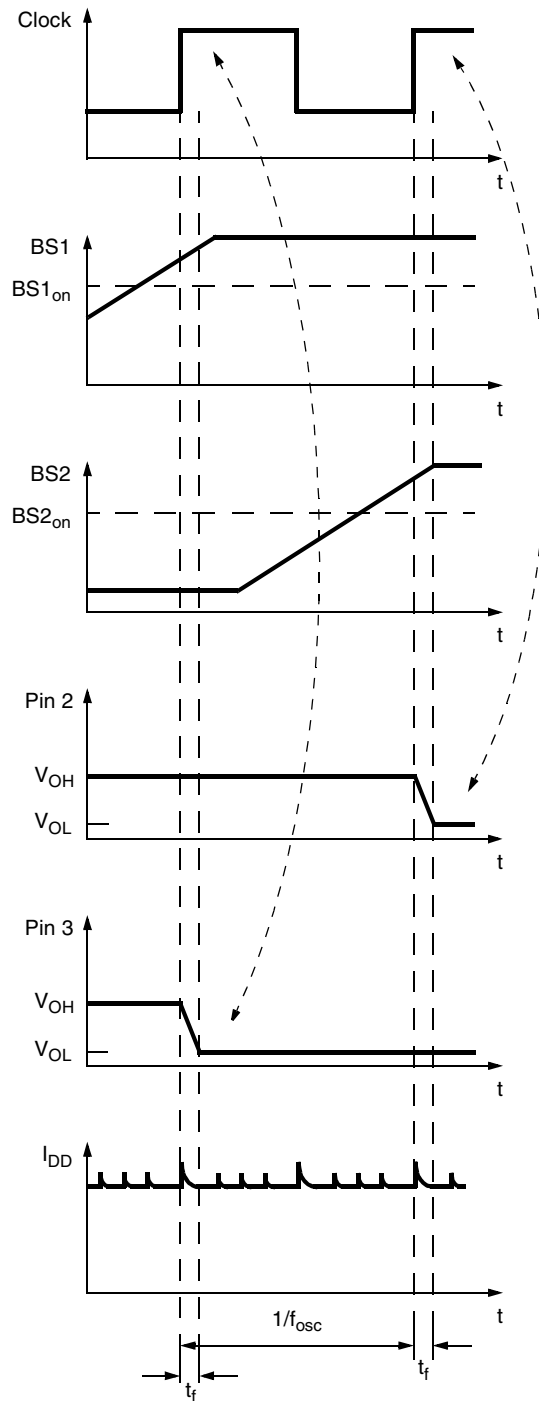

Fig. 2–1: HAL700 timing diagram with respect to the clock phase

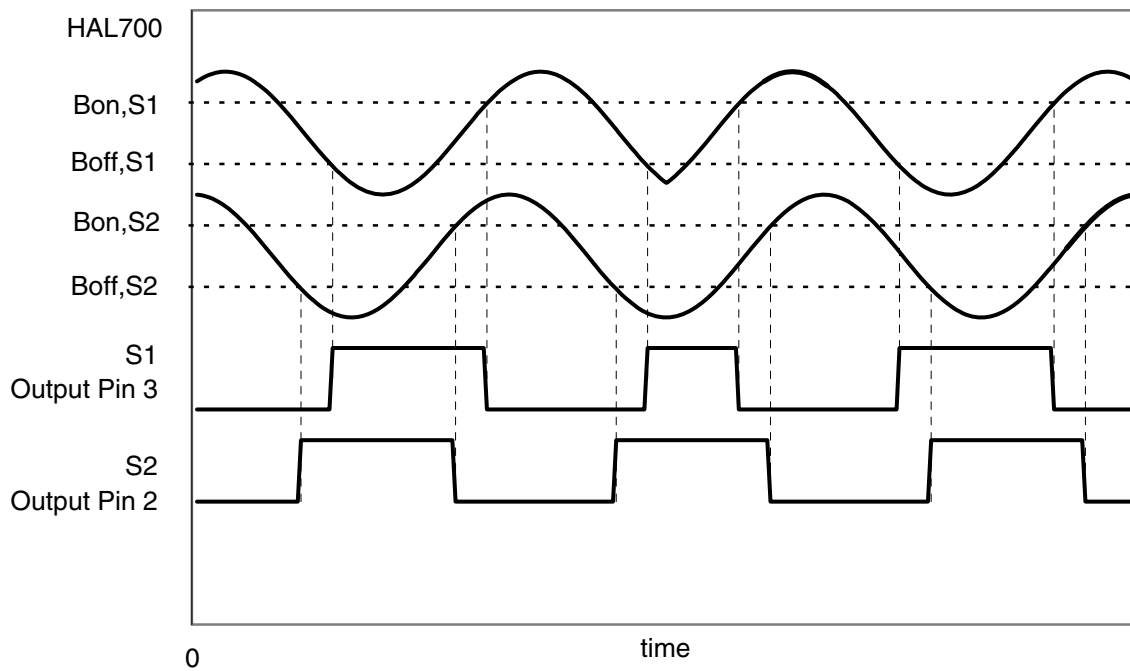

Fig. 2-2: HAL 700 timing diagram

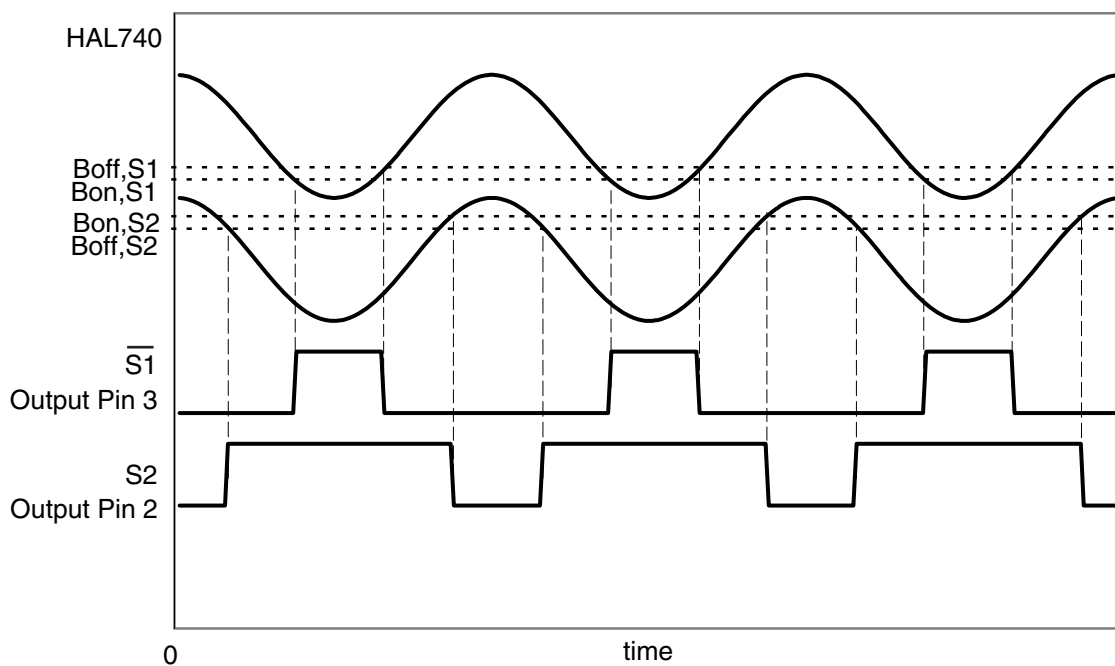

Fig. 2-3: HAL 740 timing diagram

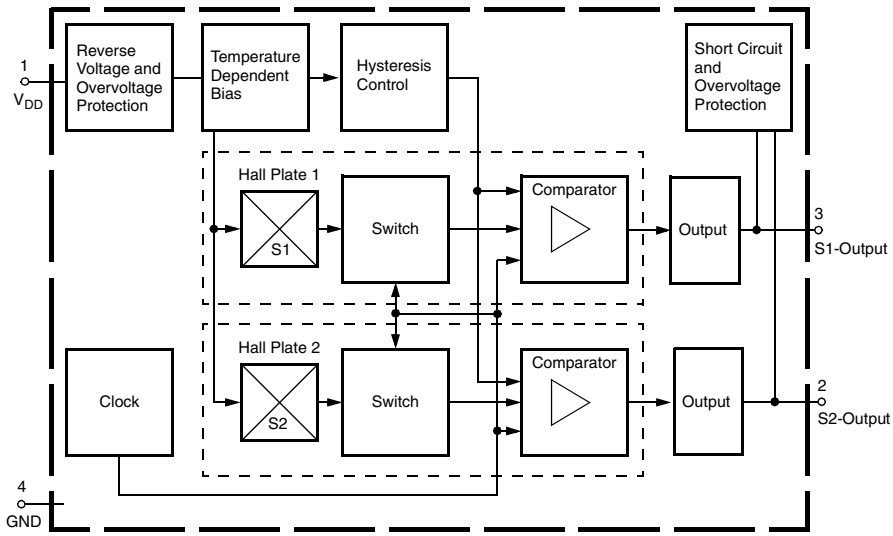

Fig. 2-4: HAL 700 and HAL 740 block diagram

3. Specifications

3.1. Outline Dimensions

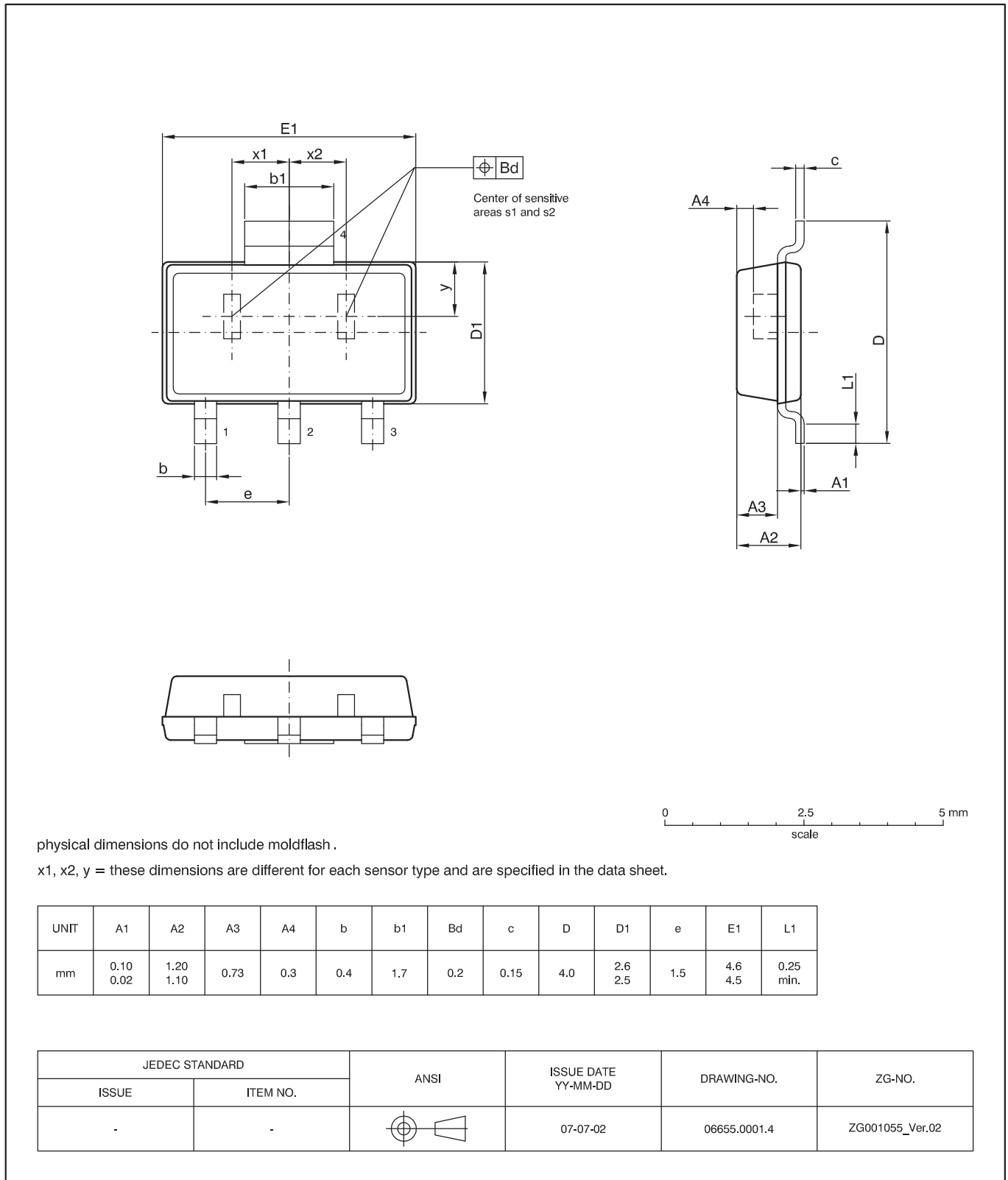

Fig. 3-1:
SOT89B-2: Plastic **S**mall **O**utline **T**ransistor package, 4 leads, with two sensitive areas
 Weight approximately 0.034 g

3.2. Dimensions of Sensitive Area

0.25 mm × 0.12 mm

3.3. Positions of Sensitive Areas

	SOT89B-2
x_1+x_2	(2.35±0.001) mm
$x_1=x_2$	1.175 mm nominal
y	0.975 mm nominal

3.4. Absolute Maximum Ratings

Stresses beyond those listed in the “Absolute Maximum Ratings” may cause permanent damage to the device. This is a stress rating only. Functional operation of the device at these conditions is not implied. Exposure to absolute maximum rating conditions for extended periods will affect device reliability.

This device contains circuitry to protect the inputs and outputs against damage due to high static voltages or electric fields; however, it is advised that normal precautions be taken to avoid application of any voltage higher than absolute maximum-rated voltages to this high-impedance circuit.

All voltages listed are referenced to ground (GND).

Symbol	Parameter	Pin No.	Min.	Max.	Unit
V_{DD}	Supply Voltage	1	-15	28 ¹⁾	V
V_O	Output Voltage	2, 3	-0.3	28 ¹⁾	V
I_O	Continuous Output Current	2, 3	-	20 ¹⁾	mA
T_J	Junction Temperature Range		-40	170	°C
¹⁾ as long as T_{Jmax} is not exceeded					

3.4.1. Storage and Shelf Life

The permissible storage time (shelf life) of the sensors is unlimited, provided the sensors are stored at a maximum of 30 °C and a maximum of 85% relative humidity. At these conditions, no Dry Pack is required.

Solderability is guaranteed for one year from the date code on the package.

3.5. Recommended Operating Conditions

Functional operation of the device beyond those indicated in the “Recommended Operating Conditions” of this specification is not implied, may result in unpredictable behavior of the device and may reduce reliability and lifetime.

All voltages listed are referenced to ground (GND).

Symbol	Parameter	Pin No.	Min.	Typ.	Max.	Unit
V_{DD}	Supply Voltage	1	3.8	–	24	V
I_O	Continuous Output Current	3	0	–	10	mA
V_O	Output Voltage (output switch off)	3	0	–	24	V

3.6. Characteristics

at $T_J = -40\text{ }^\circ\text{C}$ to $+140\text{ }^\circ\text{C}$, $V_{DD} = 3.8\text{ V}$ to 24 V , $GND = 0\text{ V}$.

at Recommended Operation Conditions if not otherwise specified in the column "Conditions".

Typical Characteristics for $T_J = 25\text{ }^\circ\text{C}$ and $V_{DD} = 5\text{ V}$.

Symbol	Parameter	Pin No.	Min.	Typ.	Max.	Unit	Test Conditions
I_{DD}	Supply Current	1	3	5.5	9	mA	$T_J = 25\text{ }^\circ\text{C}$
I_{DD}	Supply Current over Temperature Range	1	2	7	10	mA	
V_{DDZ}	Overshoot Protection at Supply	1	-	28.5	32	V	$I_{DD} = 25\text{ mA}$, $T_J = 25\text{ }^\circ\text{C}$, $t = 2\text{ ms}$
V_{OZ}	Overshoot Protection at Output	2, 3	-	28	32	V	$I_O = 20\text{ mA}$, $T_J = 25\text{ }^\circ\text{C}$, $t = 15\text{ ms}$
V_{OL}	Output Voltage	2, 3	-	130	280	mV	$I_{OL} = 10\text{ mA}$, $T_J = 25\text{ }^\circ\text{C}$
V_{OL}	Output Voltage over Temperature Range	2, 3	-	130	400	mV	$I_{OL} = 10\text{ mA}$
I_{OH}	Output Leakage Current	2, 3	-	0.06	0.1	μA	Output switched off, $T_J = 25\text{ }^\circ\text{C}$, $V_{OH} = 3.8\text{ V}$ to 24 V
I_{OH}	Output Leakage Current over Temperature Range	2, 3	-	-	10	μA	Output switched off, $T_J \leq 140\text{ }^\circ\text{C}$, $V_{OH} = 3.8\text{ V}$ to 24 V
f_{osc}	Internal Sampling Frequency over Temperature Range	-	100	150	-	kHz	
$t_{en}(O)$	Enable Time of Output after Setting of V_{DD}	1	-	50	-	μs	$V_{DD} = 12\text{ V}$, $B > B_{on} + 2\text{ mT}$ or $B < B_{off} - 2\text{ mT}$
t_r	Output Rise Time	2, 3	-	0.2	-	μs	$V_{DD} = 12\text{ V}$, $R_L = 2.4\text{ k}\Omega$, $C_L = 20\text{ pF}$
t_f	Output FallTime	2, 3	-	0.2	-	μs	$V_{DD} = 12\text{ V}$, $R_L = 2.4\text{ k}\Omega$, $C_L = 20\text{ pF}$
R_{thJSB} case SOT89B-2	Thermal Resistance Junction to Substrate Backside	-	-	150	200	K/W	Fiberglass Substrate 30 mm x 10 mm x 1.5 mm, pad size see Fig. 3-2

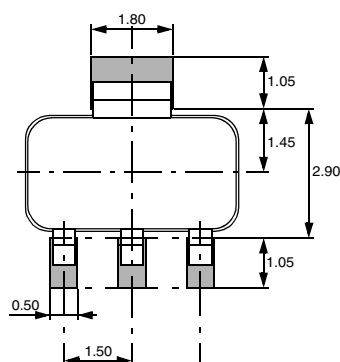
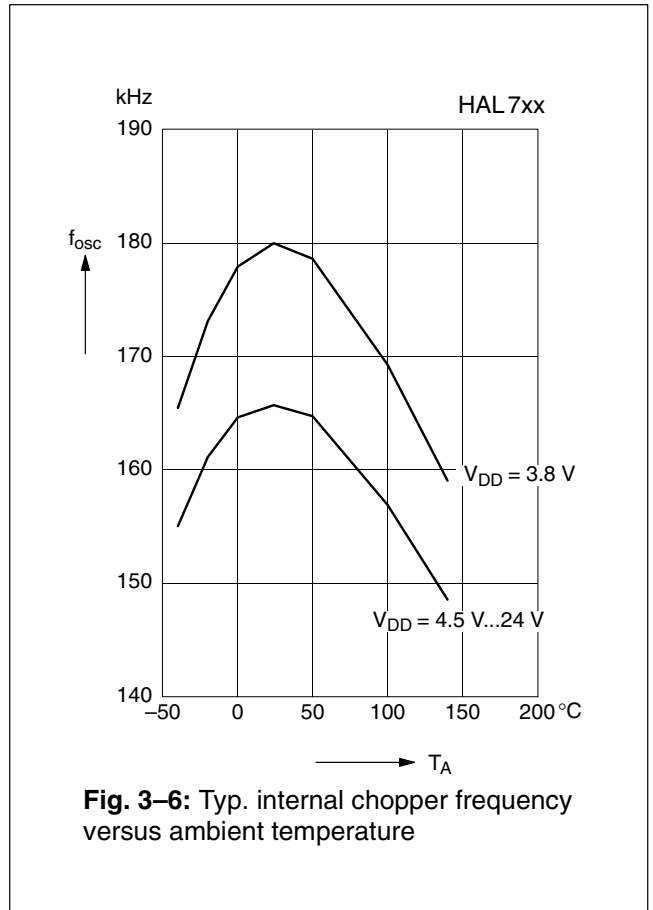
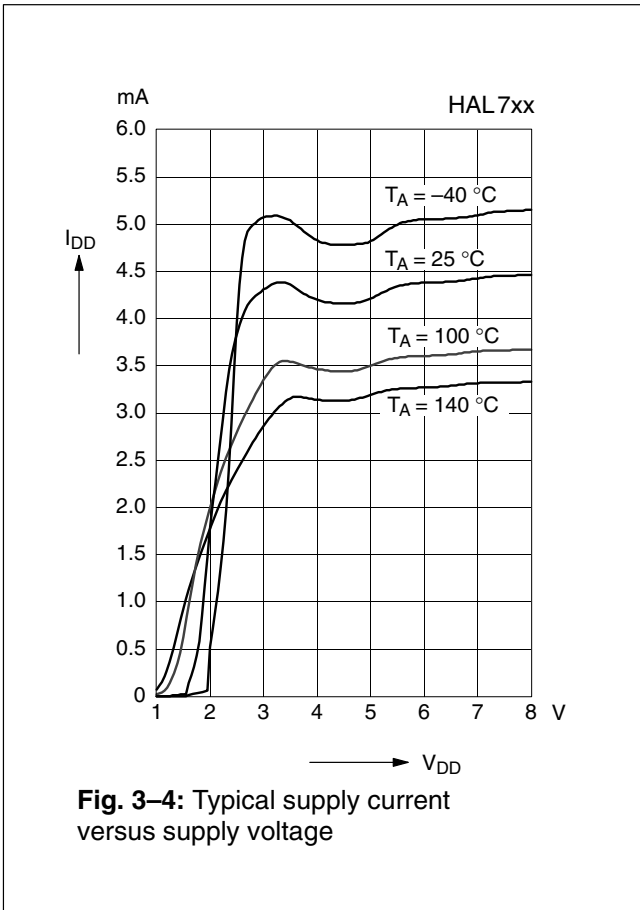
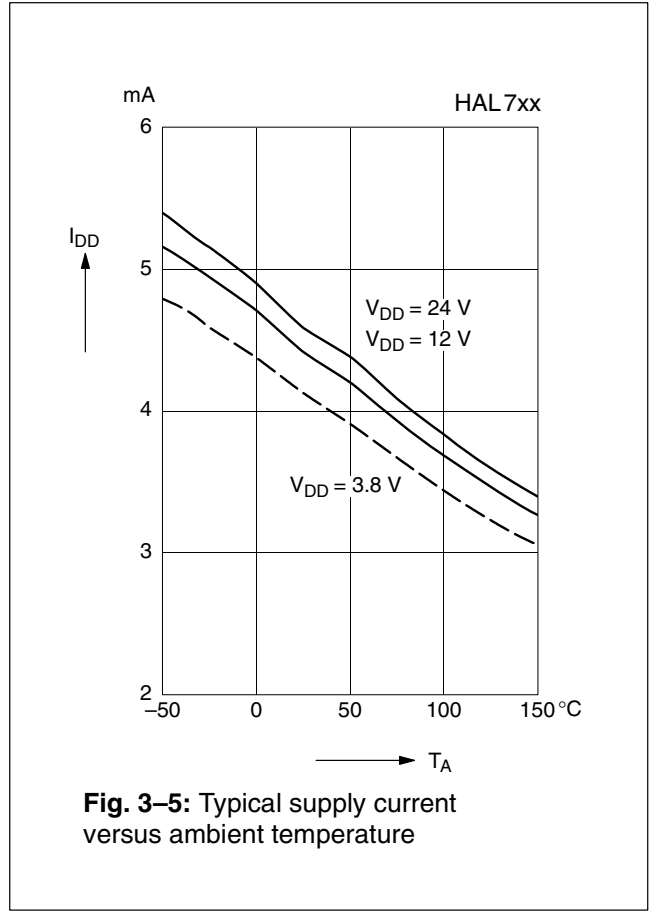
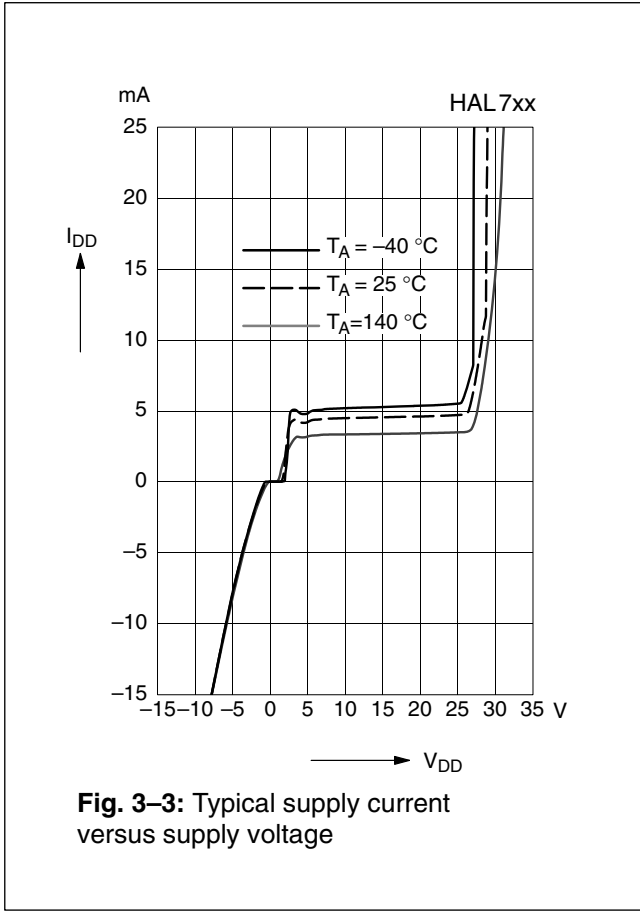
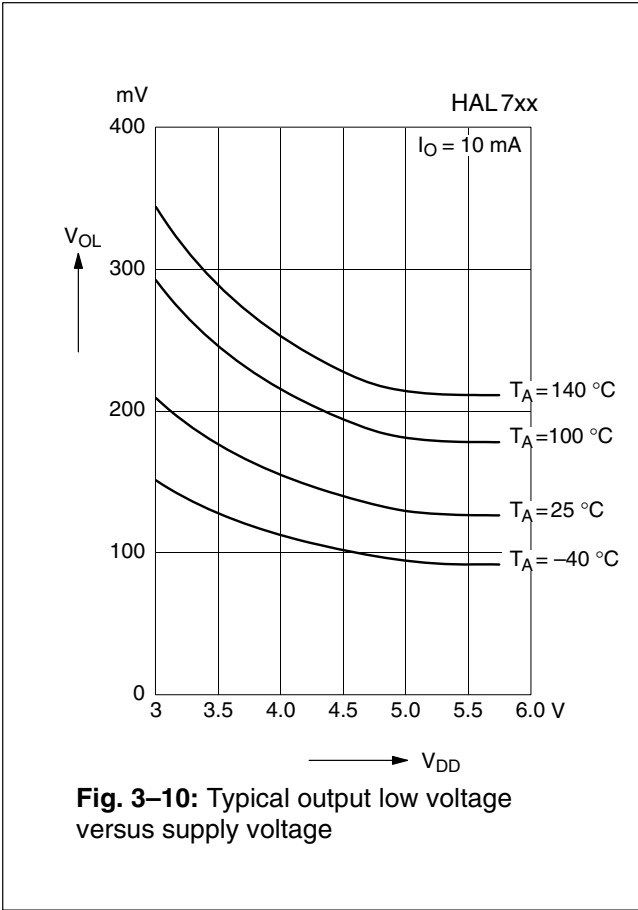
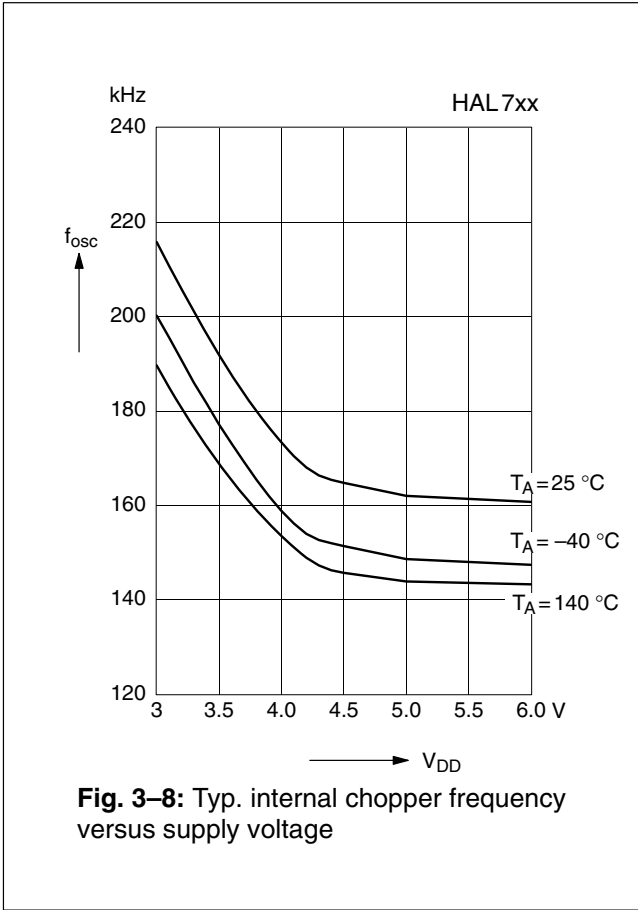
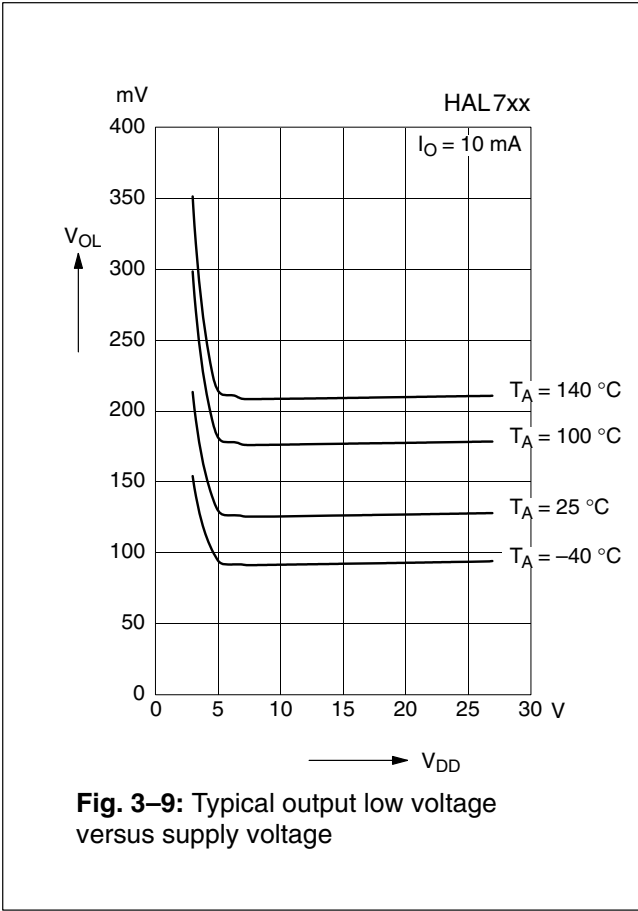
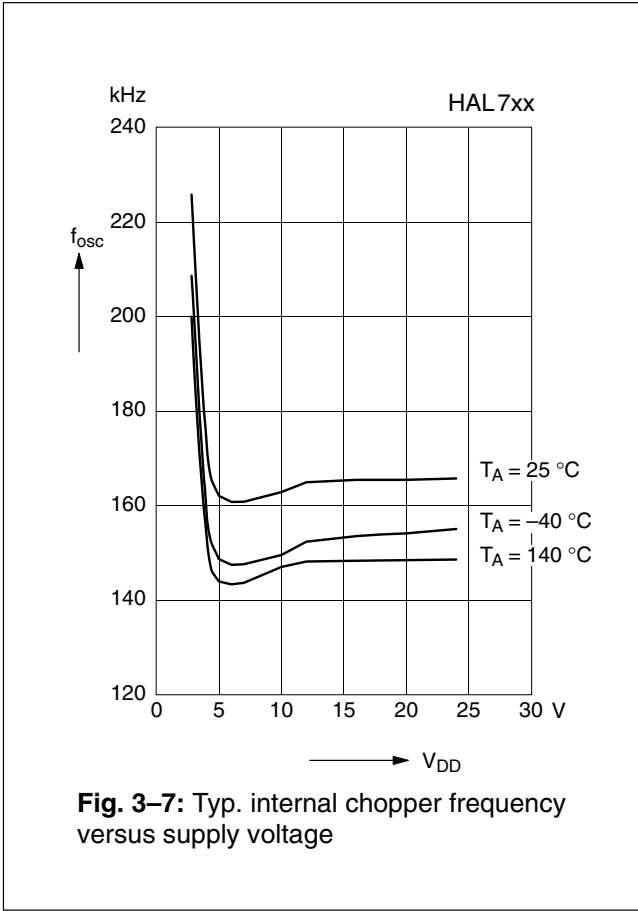
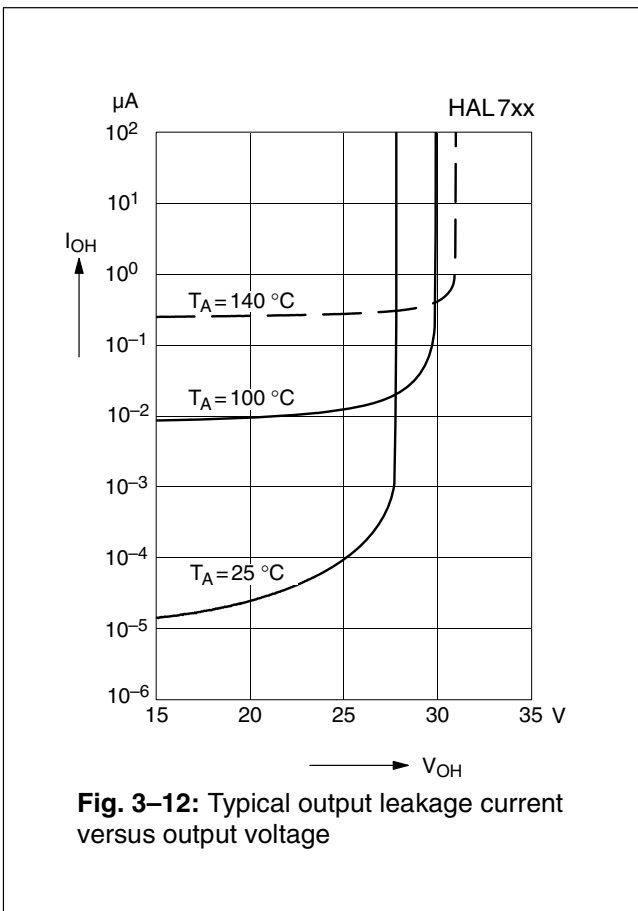
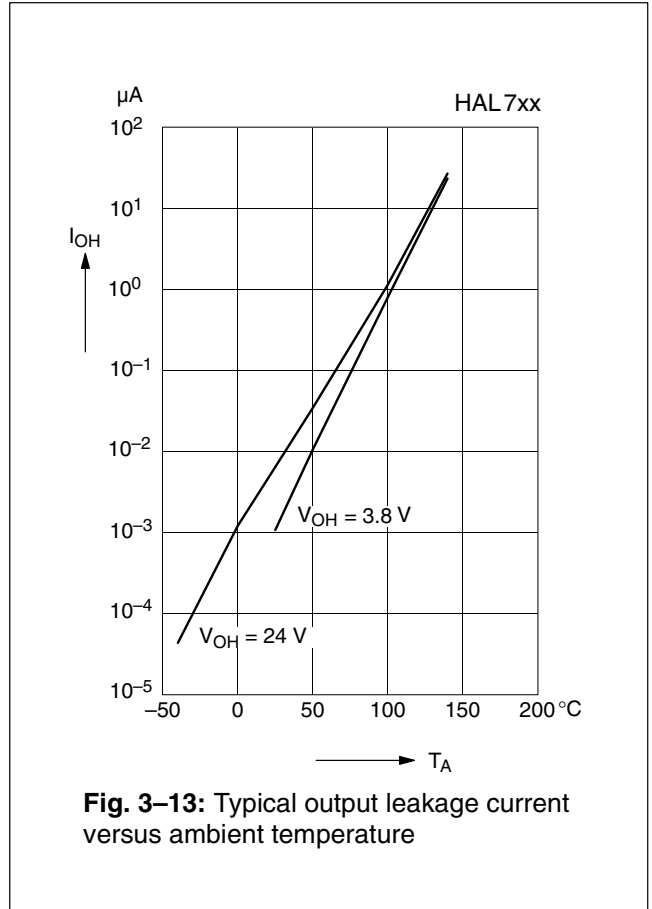
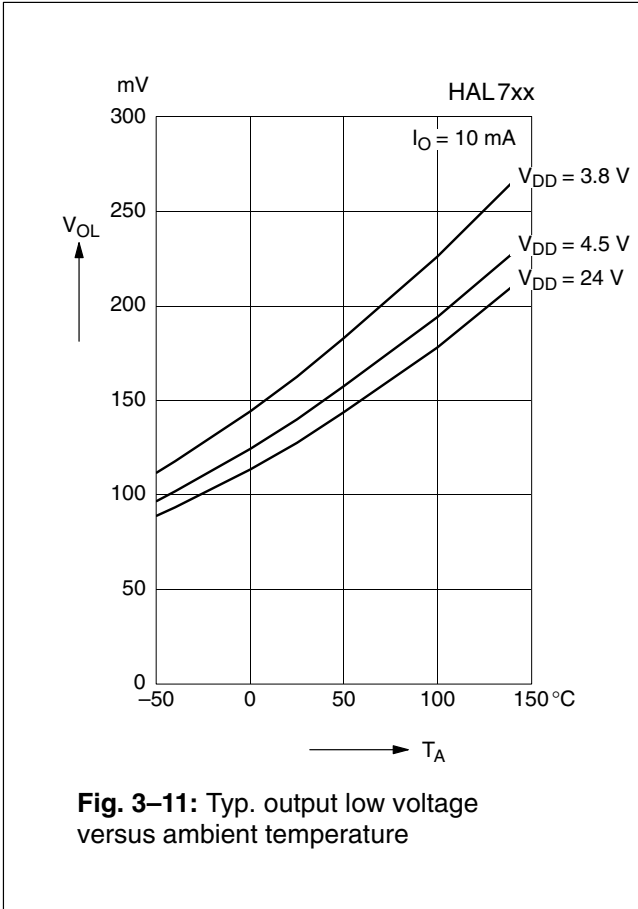

Fig. 3-2: Recommended pad size SOT89B-2
Dimensions in mm







4. Type Description

4.1. HAL700

The HAL700 consists of two independent latched switches (see Fig. 4–1) with closely matched magnetic characteristics controlling two independent open-drain outputs. The Hall plates of the two switches are spaced 2.35 mm apart.

In combination with an active target providing a sequence of alternating magnetic north and south poles, the sensor forms a system generating the signals required to control position, speed, and direction of the target movement.

Magnetic Features

- two independent Hall-switches
- distance of Hall plates: 2.35 mm
- typical B_{ON} : 14.9 mT at room temperature
- typical B_{OFF} : –14.9 mT at room temperature
- temperature coefficient of –2000 ppm/K in all magnetic characteristics
- operation with static magnetic fields and dynamic magnetic fields up to 10 kHz

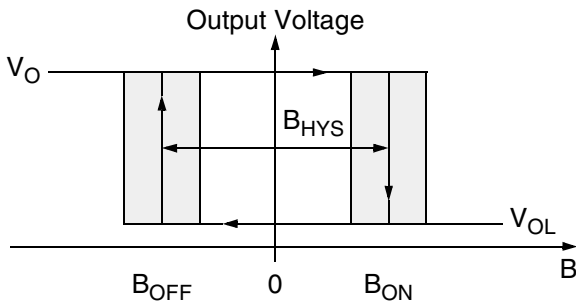

Fig. 4–1: Definition of magnetic switching points for the HAL700

Positive flux density values refer to magnetic south pole at the branded side of the package.

Applications

The HAL700 is the ideal sensors for position-control applications with direction detection and alternating magnetic signals such as:

- multipole magnet applications,
- rotating speed and direction measurement, position tracking (active targets), and
- window lifters.

Magnetic Thresholds

(quasistationary: $dB/dt < 0.5$ mT/ms)

at $T_J = -40$ °C to $+140$ °C, $V_{DD} = 3.8$ V to 24 V, as not otherwise specified

Typical characteristics for $T_J = 25$ °C and $V_{DD} = 5$ V

Parameter	On-Point B_{S1on}, B_{S2on}			Off-Point B_{S1off}, B_{S2off}			Unit
	Min.	Typ.	Max.	Min.	Typ.	Max.	
T_J							
–40 °C	12.5	16.3	20	–20	–16.3	–12.5	mT
25 °C	10.7	14.9	19.1	–19.1	–14.9	–10.7	mT
100 °C	7.7	12.5	17.3	–17.3	–12.5	–7.7	mT
140 °C	6.0	10.9	16.0	–16.0	–10.9	–6.0	mT

Matching B_{S1} and B_{S2}

(quasistationary: $dB/dt < 0.5$ mT/ms)

at $T_J = -40$ °C to $+140$ °C, $V_{DD} = 3.8$ V to 24 V, as not otherwise specified

Typical characteristics for $T_J = 25$ °C and $V_{DD} = 5$ V

Parameter	$B_{S1on} - B_{S2on}$			$B_{S1off} - B_{S2off}$			Unit
	Min.	Typ.	Max.	Min.	Typ.	Max.	
T_J							
–40 °C	–7.5	0	7.5	–7.5	0	7.5	mT
25 °C	–7.5	0	7.5	–7.5	0	7.5	mT
100 °C	–7.5	0	7.5	–7.5	0	7.5	mT
140 °C	–7.5	0	7.5	–7.5	0	7.5	mT

Hysteresis Matching

(quasistationary: $dB/dt < 0.5$ mT/ms)

at $T_J = -40$ °C to $+140$ °C, $V_{DD} = 3.8$ V to 24 V, as not otherwise specified

Typical characteristics for $T_J = 25$ °C and $V_{DD} = 5$ V

Parameter	$(B_{S1on} - B_{S1off}) / (B_{S2on} - B_{S2off})$			Unit
	Min.	Typ.	Max.	
T_J				
–40 °C	0.85	1.0	1.2	–
25 °C	0.85	1.0	1.2	–
100 °C	0.85	1.0	1.2	–
140 °C	0.85	1.0	1.2	–

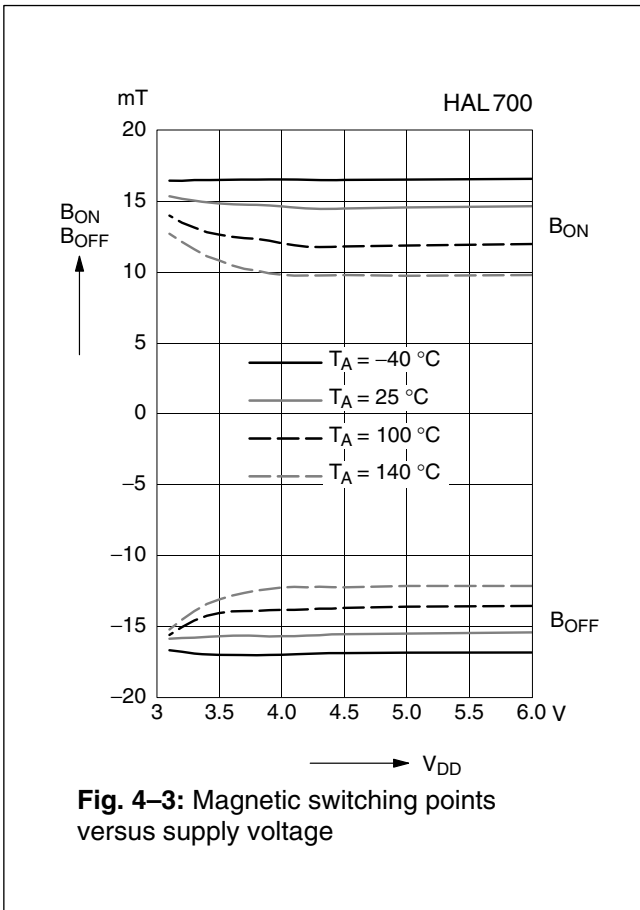
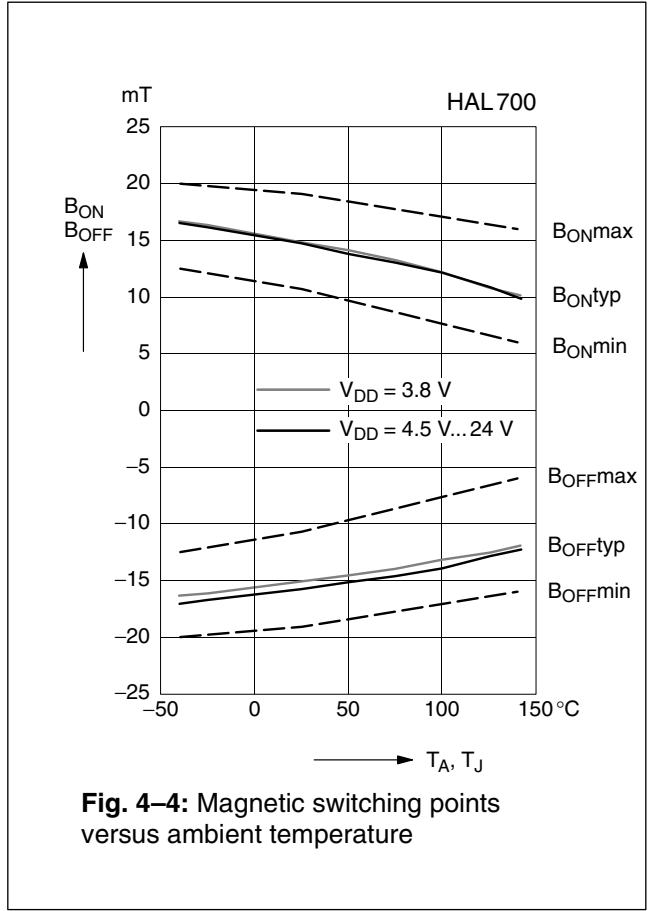
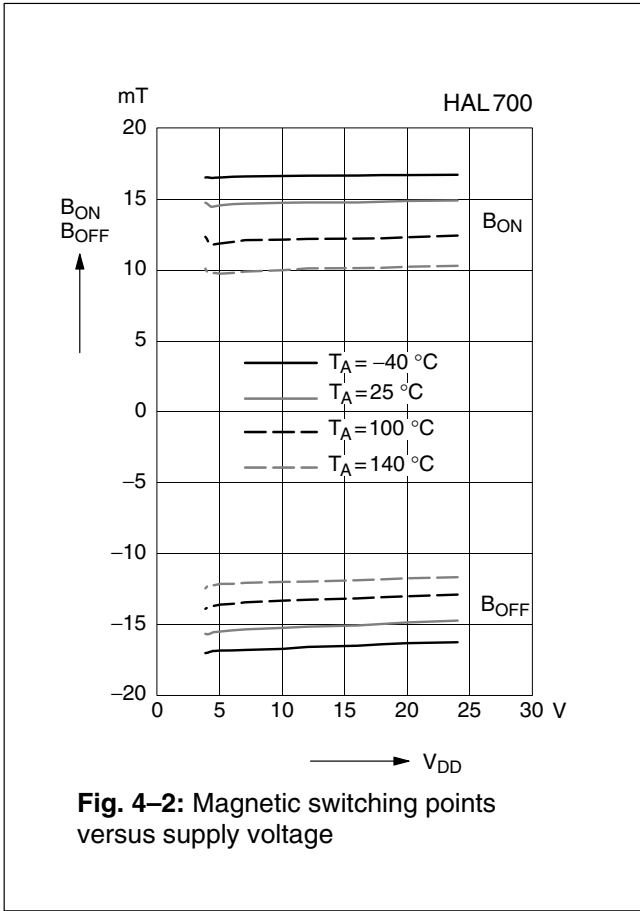

4.2. HAL740

The HAL740 consists of two independent unipolar switches (see Fig. 4–5) with complementary magnetic characteristics controlling two independent open-drain outputs. The Hall plates of the two switches are spaced 2.35 mm apart.

The S1-Output turns low with the magnetic north pole on the branded side of the package and turns high if the magnetic field is removed. It does not respond to the magnetic south pole on the branded side.

The S2-Output turns low with the magnetic south pole on the branded side of the package and turns high if the magnetic field is removed. It does not respond to the magnetic south pole on the branded side.

Magnetic Features

- two independent Hall-switches
- distance of Hall plates: 2.35 mm
- temperature coefficient of –2000 ppm/K in all magnetic characteristics
- operation with static magnetic fields and dynamic magnetic fields up to 10 kHz

Magnetic Characteristics

(quasistationary: dB/dT < 0.5 T/ms) at T_J = –40 °C to +100 °C, V_{DD} = 3.8 V to 24 V, Typical Characteristics for V_{DD} = 12 V. Absolute values common to both Hall switches. The Hall switches S1 and S2 only differ in sign. For S1 the sign is negative, for S2 positive. Positive flux density values refer to the magnetic south pole at the branded side of the package.

Parameter	On point B _{ON}			Off point B _{OFF}			Hysteresis B _{HYS}			Magnetic Offset			Unit
	Min.	Typ.	Max.	Min.	Typ.	Max.	Min.	Typ.	Max.	Min.	Typ.	Max.	
T _J –40 °C	8.5	12.3	16.0	5.0	8.8	12.5	2.0	–	5.5	–	10.6	–	mT
25 °C	7.0	11.5	16.0	3.5	8.0	12.5	2.0	–	6.0	–	9.8	–	mT
100 °C	5.5	10.8	16.0	2.0	7.0	12.5	1.5	–	6.5	–	8.9	–	mT
140 °C	4.6	10.4	16.0	1.1	6.8	12.5	1.0	–	7.0	–	8.6	–	mT

The hysteresis is the difference between the switching points $B_{HYS} = B_{ON} - B_{OFF}$
 The magnetic offset is the mean value of the switching points $B_{OFFSET} = (B_{ON} + B_{OFF}) / 2$

Applications

The HAL740 is the ideal sensor for applications which require both magnetic polarities, such as:

- position and direction detection, or
- position and end point detection with either magnetic pole (omnipolar switch).

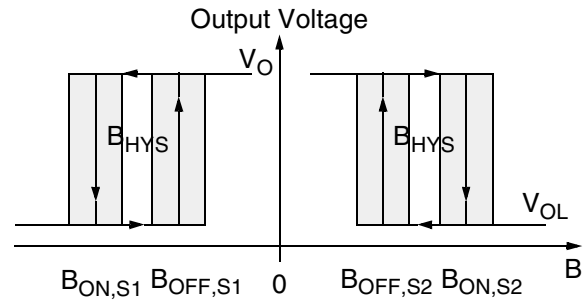
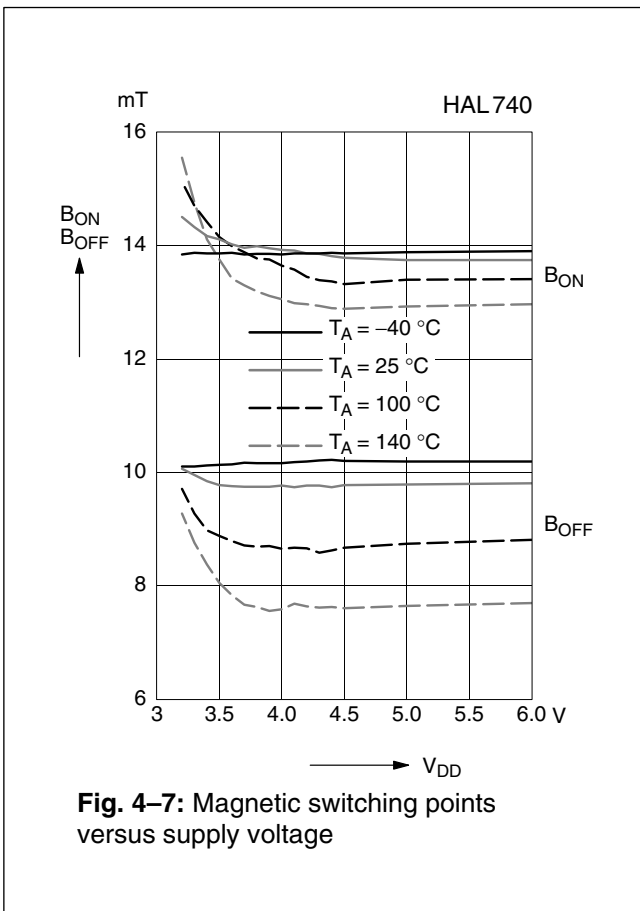
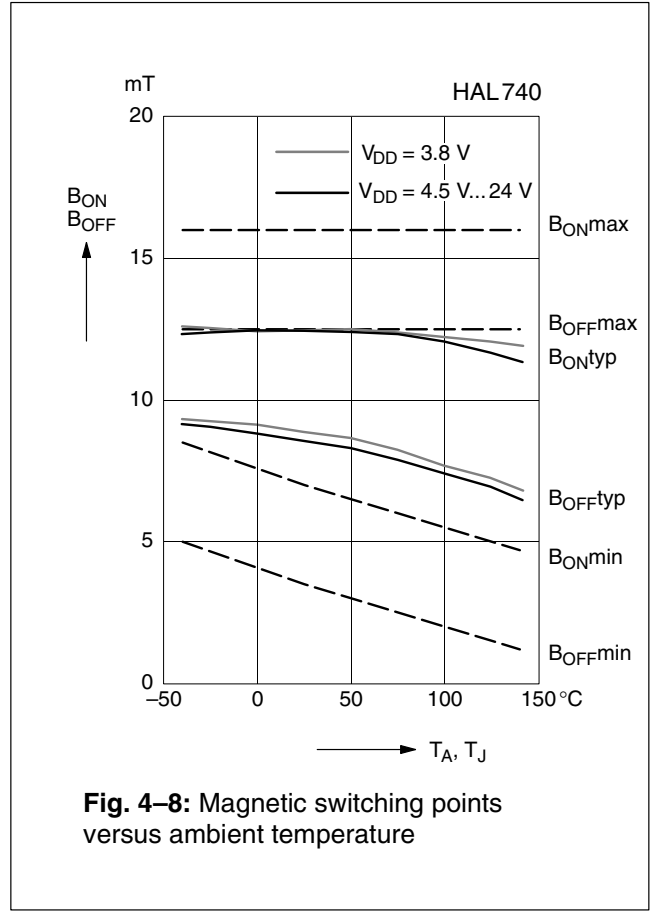
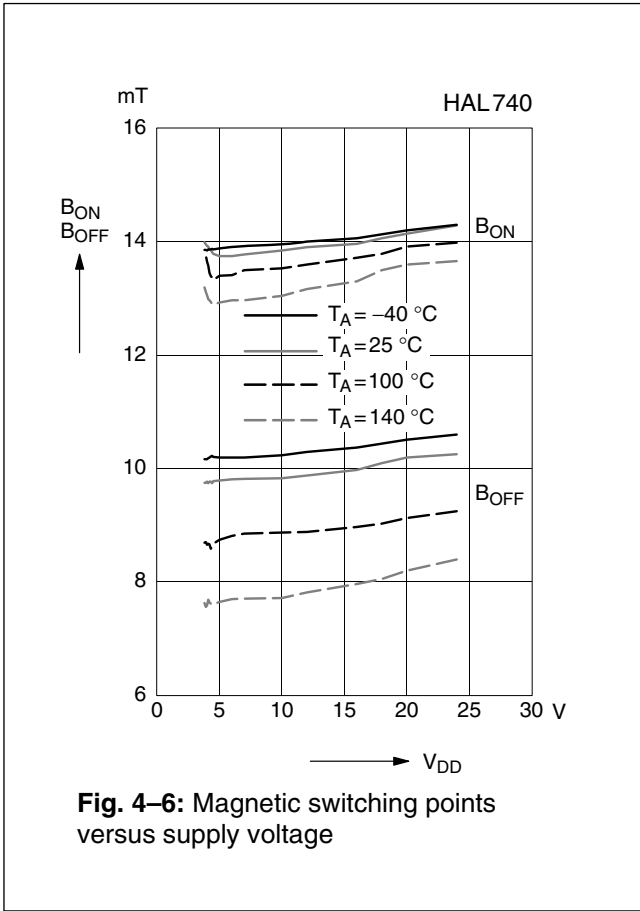

Fig. 4–5: Definition of magnetic switching points for the HAL740



5. Application Notes

5.1. Ambient Temperature

Due to the internal power dissipation, the temperature on the silicon chip (junction temperature T_J) is higher than the temperature outside the package (ambient temperature T_A).

$$T_J = T_A + \Delta T$$

At static conditions and continuous operation, the following equation applies:

$$\Delta T = I_{DD} * V_{DD} * R_{th}$$

For typical values, use the typical parameters. For worst case calculation, use the max. parameters for I_{DD} and R_{th} , and the max. value for V_{DD} from the application.

For all sensors, the junction temperature range T_J is specified. The maximum ambient temperature T_{Amax} can be calculated as:

$$T_{Amax} = T_{Jmax} - \Delta T$$

5.2. Extended Operating Conditions

All sensors fulfill the electrical and magnetic characteristics when operated within the Recommended Operating Conditions (see Section 3.5. on page 11).

Supply Voltage Below 3.8 V

Typically, the sensors operate with supply voltages above 3 V, however, below 3.8 V some characteristics may be outside the specification.

Note: The functionality of the sensor below 3.8 V is not tested. For special test conditions, please contact Micronas.

5.3. Start-up Behavior

Due to the active offset compensation, the sensors have an initialization time (enable time $t_{en(O)}$) after applying the supply voltage. The parameter $t_{en(O)}$ is specified in the “Characteristics” (see Section 3.6. on page 12).

During the initialization time, the output states are not defined and the outputs can toggle. After $t_{en(O)}$, both outputs will be either high or low for a stable magnetic field (no toggling). The outputs will be low if the applied magnetic flux density B exceeds B_{ON} and high if B drops below B_{OFF} .

For magnetic fields between B_{OFF} and B_{ON} , the output states of the Hall sensor after applying V_{DD} will be either low or high. In order to achieve a well-defined output state, the applied magnetic flux density must be above B_{ONmax} , respectively, below B_{OFFmin} .

5.4. EMC and ESD

For applications that cause disturbances on the supply line or radiated disturbances, a series resistor and a capacitor are recommended (see Fig. 5–1). The series resistor and the capacitor should be placed as closely as possible to the Hall sensor.

Please contact Micronas for detailed investigation reports with EMC and ESD results.

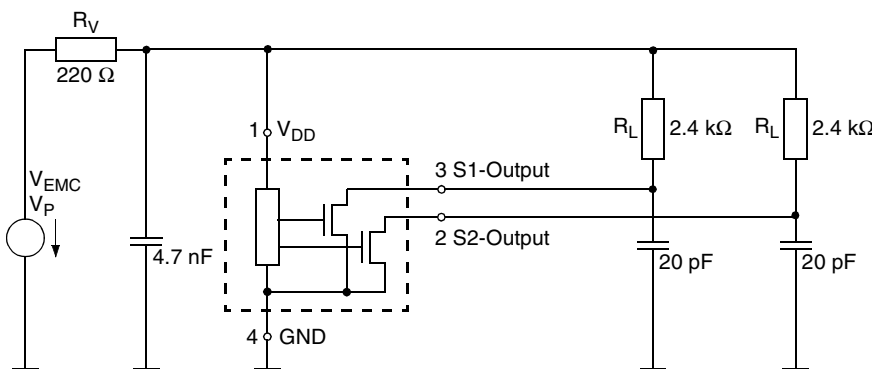

Fig. 5–1: Test circuit for EMC investigations

intentionally left vacant

6. Data Sheet History

1. : “HAL700, HAL740 Dual Hall-Effect Sensors with Independent Outputs”, June 13, 2002, 6251-477-1DS. First release of the data sheet.
2. Data Sheet: “HAL700, HAL740 Dual Hall-Effect Sensors with Independent Outputs”, Sept. 13, 2004, 6251-477-2DS. Second release of the data sheet.
Major changes:
 - new package diagram for SOT89B-2
3. Data Sheet: “HAL700, HAL740 Dual Hall-Effect Sensors with Independent Outputs”, Nov. 30, 2009, DSH000029_002EN. Third release of the data sheet.
Major changes:
 - Section 1.6. “Solderability and Welding” updated
 - Section 2–3 HAL740 timing diagram
 - Section 3.1. package diagram updated
 - Section 3.6. Recommended footprint SOT89B added