

Data Sheet

HAL[®] 54x

Hall-Effect Sensor Family

Copyright, Warranty, and Limitation of Liability

The information and data contained in this document are believed to be accurate and reliable. The software and proprietary information contained therein may be protected by copyright, patent, trademark and/or other intellectual property rights of Micronas. All rights not expressly granted remain reserved by Micronas.

Micronas assumes no liability for errors and gives no warranty representation or guarantee regarding the suitability of its products for any particular purpose due to these specifications.

By this publication, Micronas does not assume responsibility for patent infringements or other rights of third parties which may result from its use. Commercial conditions, product availability and delivery are exclusively subject to the respective order confirmation.

Any information and data which may be provided in the document can and do vary in different applications, and actual performance may vary over time.

All operating parameters must be validated for each customer application by customers' technical experts. Any new issue of this document invalidates previous issues. Micronas reserves the right to review this document and to make changes to the document's content at any time without obligation to notify any person or entity of such revision or changes. For further advice please contact us directly.

Do not use our products in life-supporting systems, aviation and aerospace applications! Unless explicitly agreed to otherwise in writing between the parties, Micronas' products are not designed, intended or authorized for use as components in systems intended for surgical implants into the body, or other applications intended to support or sustain life, or for any other application in which the failure of the product could create a situation where personal injury or death could occur.

No part of this publication may be reproduced, photocopied, stored on a retrieval system or transmitted without the express written consent of Micronas.

Micronas Trademarks

– HAL

Micronas Patents

Choppered Offset Compensation protected by Micronas patents no. US5260614, US5406202, EP0525235 and EP0548391.

Third-Party Trademarks

All other brand and product names or company names may be trademarks of their respective companies.

Contents, continued

Page	Section	Title
4	1.	Introduction
4	1.1.	Features
4	1.2.	Family Overview
5	1.3.	Marking Code
5	1.4.	Operating Junction Temperature Range
5	1.5.	Hall Sensor Package Codes
5	1.6.	Solderability and Welding
5	1.7.	Pin Connections
6	2.	Functional Description
7	3.	Specifications
7	3.1.	Outline Dimensions
12	3.2.	Dimensions of Sensitive Area
12	3.3.	Positions of Sensitive Areas
12	3.4.	Absolute Maximum Ratings
12	3.4.1.	Storage and Shelf Life
13	3.5.	Recommended Operating Conditions
14	3.6.	Characteristics
15	3.7.	Magnetic Characteristics Overview
19	4.	Type Description
19	4.1.	HAL542
21	4.2.	HAL543
23	4.3.	HAL546
25	4.4.	HAL548
27	5.	Application Notes
27	5.1.	Ambient Temperature
27	5.2.	Extended Operating Conditions
27	5.3.	Start-up Behavior
27	5.4.	EMC and ESD
28	6.	Data Sheet History

Hall-Effect Sensor Family

Release Note: Revision bars indicate significant changes to the previous edition.

1. Introduction

The HAL54x family consists of different Hall switches produced in CMOS technology. All sensors include a temperature-compensated Hall plate with active offset compensation, a comparator, and an open-drain output transistor. The comparator compares the actual magnetic flux through the Hall plate (Hall voltage) with the fixed reference values (switching points). Accordingly, the output transistor is switched on or off.

In addition to the HAL50x/51x family, the HAL54x features a power-on and undervoltage reset.

The sensors of this family differ in the switching behavior and the switching points.

The active offset compensation leads to constant magnetic characteristics over supply voltage and temperature range. In addition, the magnetic parameters are robust against mechanical stress effects.

The sensors are designed for industrial and automotive applications and operate with supply voltages from 4.3 V to 24 V in the ambient temperature range from -40°C up to 150°C.

All sensors are available in the SMD-package SOT89B-1 and in the leaded versions TO92UA-1 and TO92UA-2.

1.1. Features

- switching offset compensation at typically 62 kHz
- operates from 4.3 V to 24 V supply voltage
- overvoltage protection at all pins
- reverse-voltage protection at V_{DD}-pin
- magnetic characteristics are robust against mechanical stress effects
- short-circuit protected open-drain output by thermal shut down
- operates with static magnetic fields and dynamic magnetic fields up to 10 kHz
- constant switching points over a wide supply voltage range
- the decrease of magnetic flux density caused by rising temperature in the sensor system is compensated by a built-in negative temperature coefficient of the magnetic characteristics

- ideal sensor for applications in extreme automotive and industrial environments
- EMC corresponding to ISO 7637

1.2. Family Overview

The types differ according to the magnetic flux density values for the magnetic switching points and the temperature behavior of the magnetic switching points.

Type	Switching Behavior	Sensitivity	see Page
542	latching	high	19
543	unipolar	low	21
546	unipolar	high	23
548	unipolar	medium	25

Latching Sensors:

The output turns low with the magnetic south pole on the branded side of the package and turns high with the magnetic north pole on the branded side. The output does not change if the magnetic field is removed. For changing the output state, the opposite magnetic field polarity must be applied.

Unipolar Sensors:

The output turns low with the magnetic south pole on the branded side of the package and turns high if the magnetic field is removed. The sensor does not respond to the magnetic north pole on the branded side.

1.3. Marking Code

All Hall sensors have a marking on the package surface (branded side). This marking includes the name of the sensor and the temperature range.

Type	Temperature Range	
	K	E
HAL542	542K	542E
HAL543	543K	543E
HAL546	546K	546E
HAL548	548K	548E

1.4. Operating Junction Temperature Range

The Hall sensors from Micronas are specified to the chip temperature (junction temperature T_J).

K: $T_J = -40\text{ °C to }+140\text{ °C}$

E: $T_J = -40\text{ °C to }+100\text{ °C}$

Note: Due to power dissipation, there is a difference between the ambient temperature (T_A) and junction temperature. Please refer to section 5.1. on page 27 for details.

1.5. Hall Sensor Package Codes

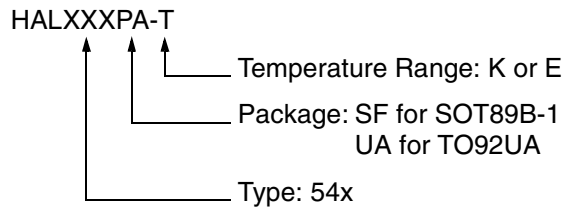

Example: **HAL542UA-K**

- Type: 542
- Package: TO92UA
- Temperature Range: $T_J = -40\text{ °C to }+140\text{ °C}$

Hall sensors are available in a wide variety of packaging versions and quantities. For more detailed information, please refer to the brochure: "Hall Sensors: Ordering Codes, Packaging, Handling".

1.6. Solderability and Welding

Soldering

During soldering reflow processing and manual reworking, a component body temperature of 260 °C should not be exceeded.

Welding

Device terminals should be compatible with laser and resistance welding. Please note that the success of the welding process is subject to different welding parameters which will vary according to the welding technique used. A very close control of the welding parameters is absolutely necessary in order to reach satisfying results. Micronas, therefore, does not give any implied or express warranty as to the ability to weld the component.

1.7. Pin Connections

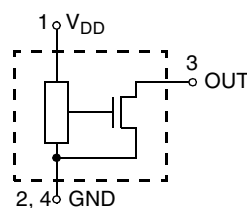

Fig. 1-1: Pin configuration

2. Functional Description

The Hall effect sensor is a monolithic integrated circuit that switches in response to magnetic fields. If a magnetic field with flux lines perpendicular to the sensitive area is applied to the sensor, the biased Hall plate forces a Hall voltage proportional to this field. The Hall voltage is compared with the actual threshold level in the comparator. The temperature-dependent bias increases the supply voltage of the Hall plates and adjusts the switching points to the decreasing induction of magnets at higher temperatures. If the magnetic field exceeds the threshold levels, the open drain output switches to the appropriate state. The built-in hysteresis eliminates oscillation and provides switching behavior of output without bouncing.

Magnetic offset caused by mechanical stress is compensated for by using the “switching offset compensation technique”. Therefore, an internal oscillator provides a two phase clock. The Hall voltage is sampled at the end of the first phase. At the end of the second phase, both sampled and actual Hall voltages are averaged and compared with the actual switching point. Subsequently, the open drain output switches to the appropriate state. The time from crossing the magnetic switching level to switching of output can vary between zero and $1/f_{osc}$.

Shunt protection devices clamp voltage peaks at the Output-pin and V_{DD} pin together with external series resistors. Reverse current is limited at the V_{DD} pin by an internal series resistor up to -15 V. No external reverse protection diode is needed at the V_{DD} pin for reverse voltages ranging from 0 V to -15 V.

A built-in reset-circuit clamps the output to the “high” state (reset state) during power-on or when the supply voltage drops below a reset voltage of $V_{reset} < 4.3$ V.

For supply voltages between V_{reset} and 4.3 V, the output state of the device responds to the magnetic field. For supply voltages above 4.3 V, the device works according to the specified characteristics.

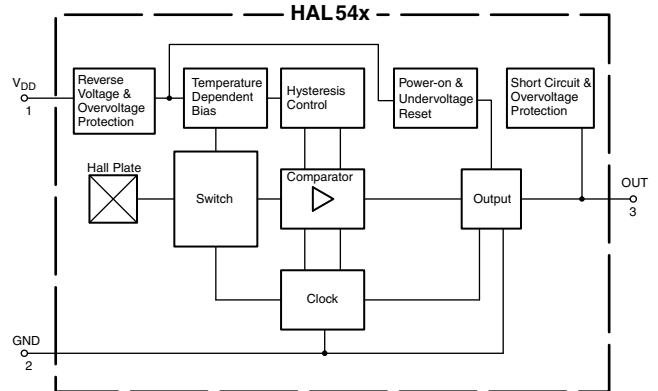

Fig. 2-1: HAL54x block diagram

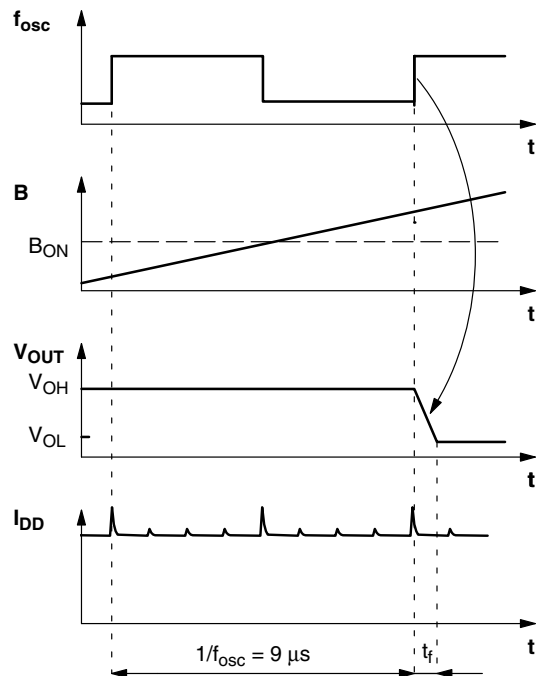

Fig. 2-2: Timing diagram

3. Specifications

3.1. Outline Dimensions

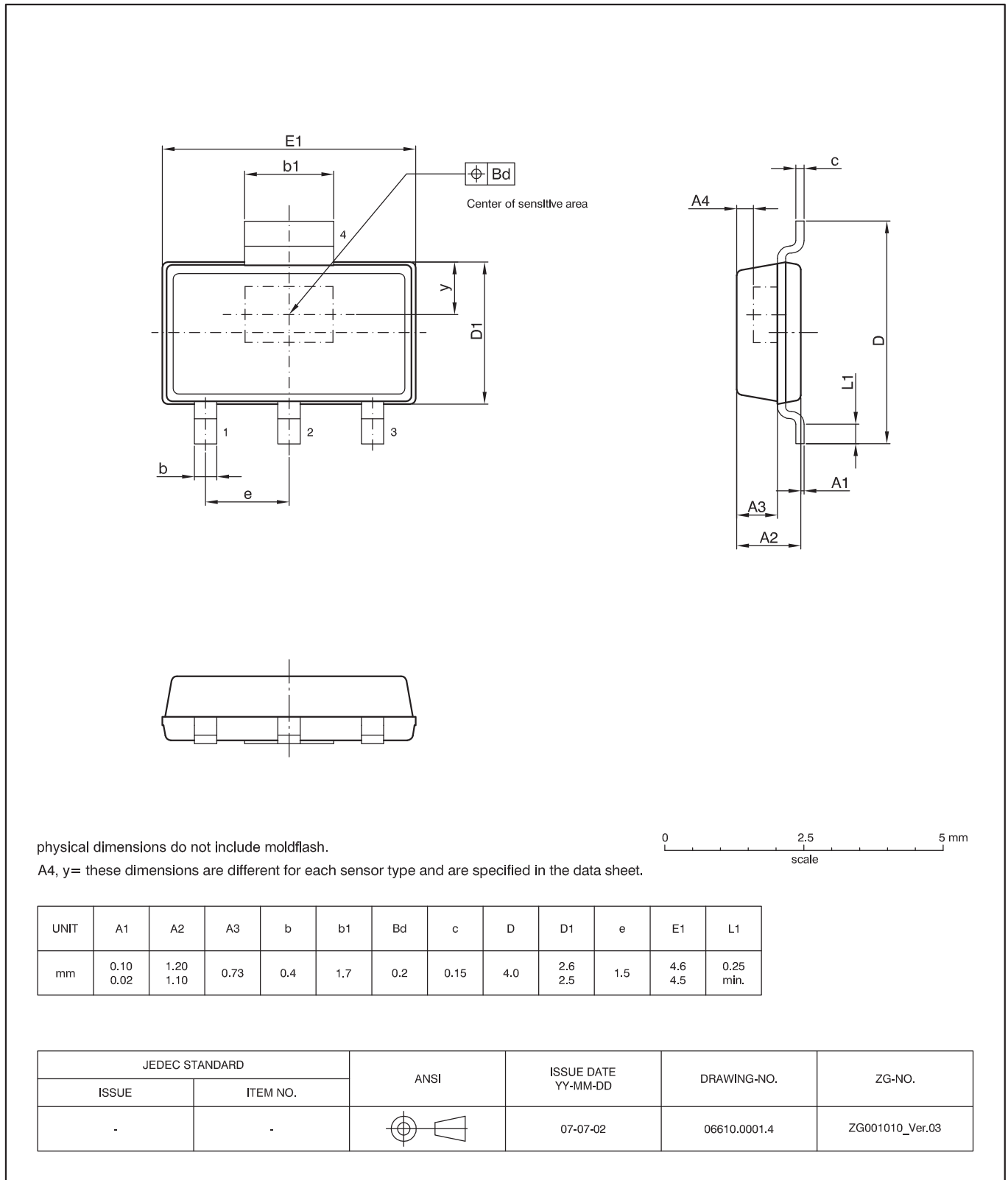
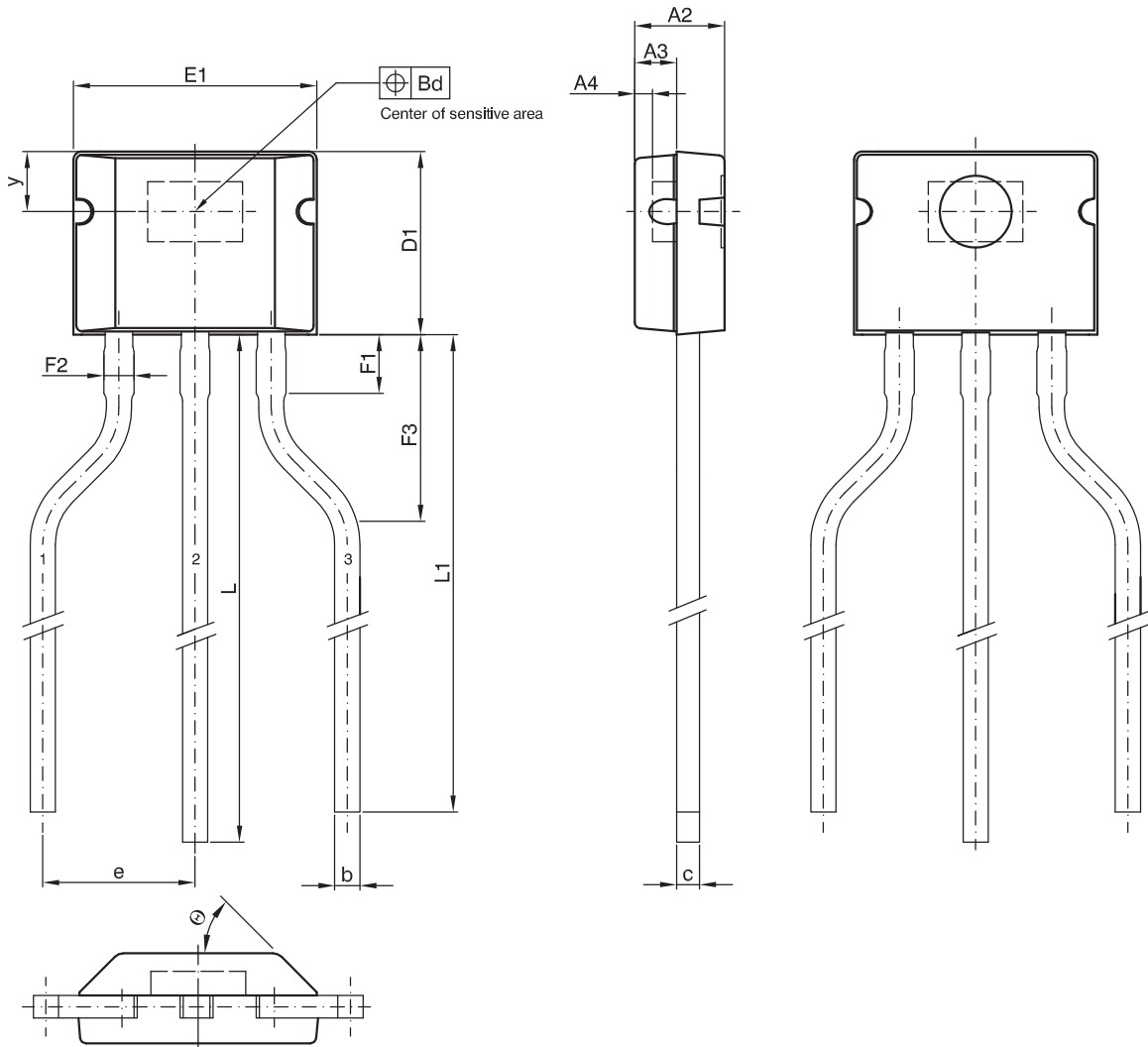

Fig. 3-1:
SOT89B-1: Plastic Small Outline Transistor package, 4 leads
 Ordering code: SF
 Weight approximately 0.034 g



physical dimensions do not include moldflash.

solderability is guaranteed between end of pin and distance F1.

y= this dimension is different for each sensor type and is specified in the data sheet.

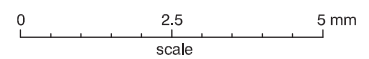

UNIT	A2	A3	A4	b	Bd	c	D1	e	E1	F1	F2	F3	L	L1	θ
mm	1.55 1.45	0.7	0.3	0.42	0.2	0.36	3.1 3.0	2.54	4.11 4.01	1.2 0.8	0.60 0.42	4.0 2.0	15.5 min	14.5 min	45°

JEDEC STANDARD		ANSI	ISSUE DATE YY-MM-DD	DRAWING-NO.	ZG-NO.
ISSUE	ITEM NO.				
-	-		07-07-03	06616.0001.4	ZG001016_Ver.03

Fig. 3-2:
TO92UA-1: Plastic Transistor Standard UA package, 3 leads, spread
 Weight approximately 0.106 g

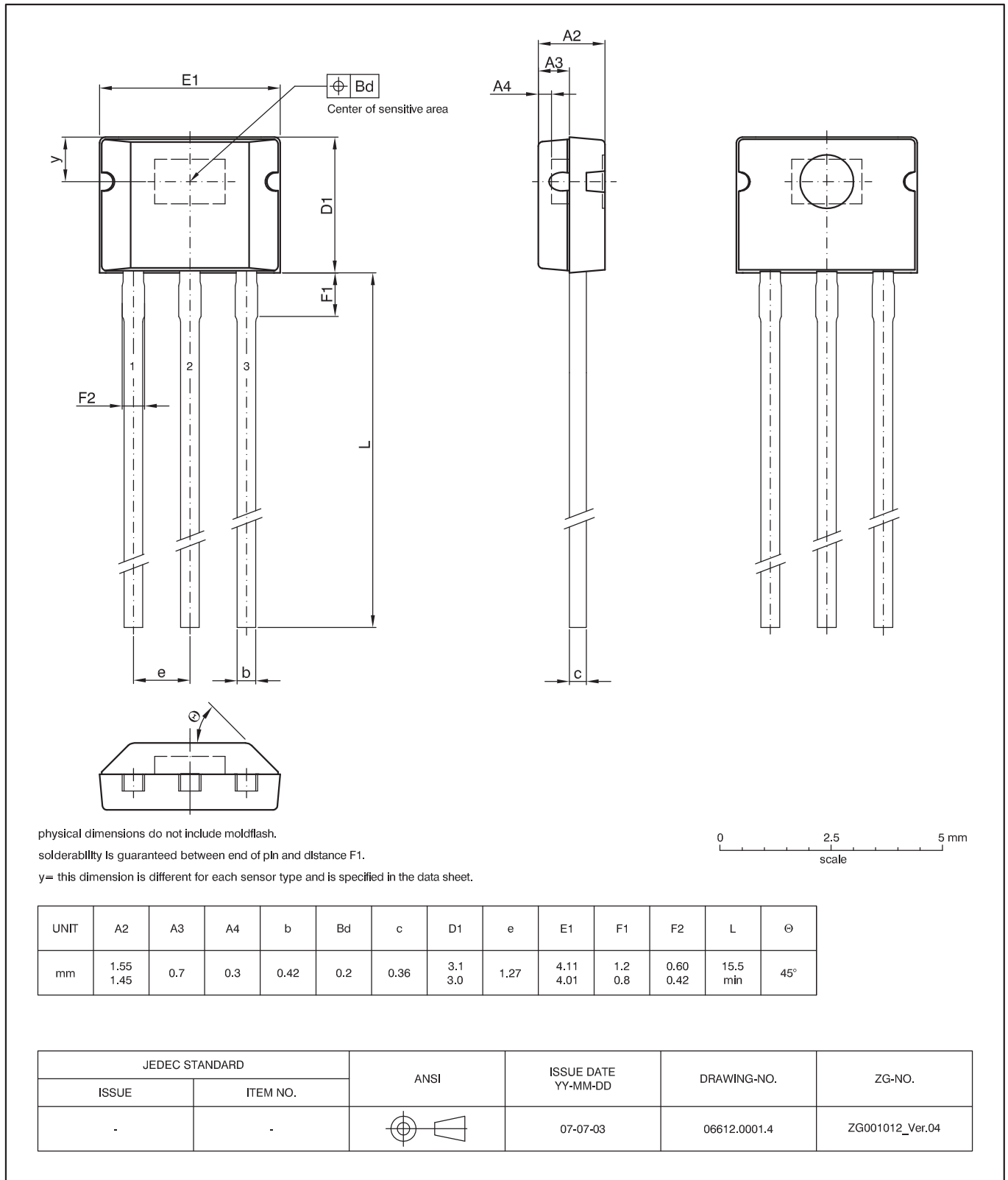

Fig. 3-3:
TO92UA-2: Plastic Transistor Standard UA package, 3 leads, not spread
 Weight approximately 0.106 g

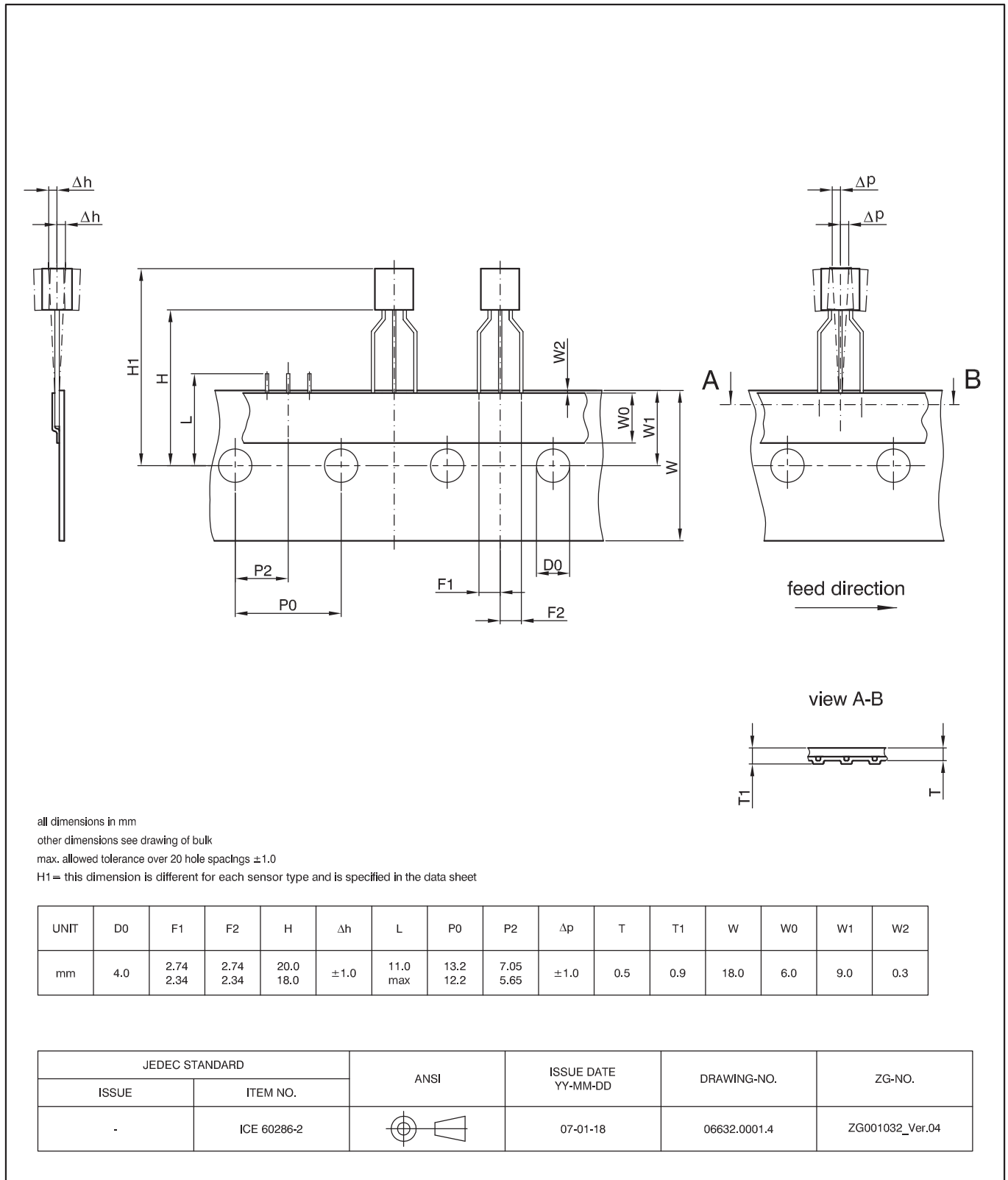
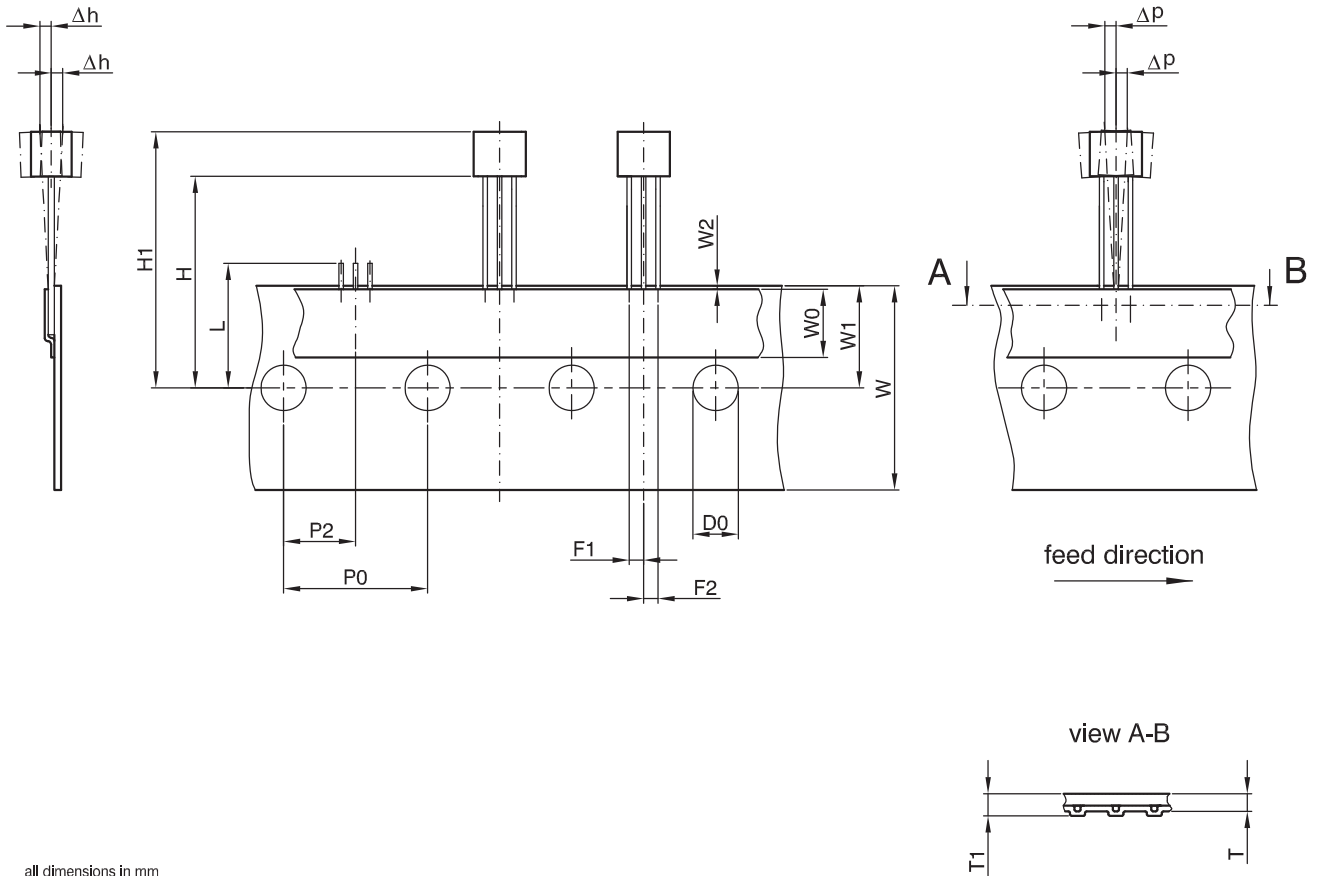

Fig. 3-4:
TO92UA-1: Dimensions ammopack inline, spread



all dimensions in mm
 other dimensions see drawing of bulk
 max. allowed tolerance over 20 hole spacings ± 1.0
 $H1$ = this dimension is different for each sensor type and is specified in the data sheet

UNIT	D0	F1	F2	H	Δh	L	P0	P2	Δp	T	T1	W	W0	W1	W2
mm	4.0	1.47 1.07	1.47 1.07	20.0 18.0	± 1.0	11.0 max	13.2 12.2	7.05 5.65	± 1.0	0.5	0.9	18.0	6.0	9.0	0.3

JEDEC STANDARD		ANSI	ISSUE DATE YY-MM-DD	DRAWING-NO.	ZG-NO.
ISSUE	ITEM NO.				
-	ICE 60286-2		07-01-18	06631.0001.4	ZG001031_Ver.03

Fig. 3-5:
TO92UA-2: Dimensions ammpack inline, not spread

3.2. Dimensions of Sensitive Area

0.25 mm × 0.12 mm

3.3. Positions of Sensitive Areas

	SOT89B-1	TO92UA-1/-2
y	0.95 mm nominal	1.0 mm nominal
A4	0.3 mm nominal	

3.4. Absolute Maximum Ratings

Stresses beyond those listed in the “Absolute Maximum Ratings” may cause permanent damage to the device. This is a stress rating only. Functional operation of the device at these conditions is not implied. Exposure to absolute maximum rating conditions for extended periods will affect device reliability.

This device contains circuitry to protect the inputs and outputs against damage due to high static voltages or electric fields; however, it is advised that normal precautions be taken to avoid application of any voltage higher than absolute maximum-rated voltages to this high-impedance circuit.

All voltages listed are referenced to ground (GND).

Symbol	Parameter	Pin No.	Min.	Max.	Unit
V _{DD}	Supply Voltage	1	-15	28 ¹⁾	V
V _O	Output Voltage	3	-0.3	28 ¹⁾	V
I _O	Continuous Output On Current	3	-	50 ¹⁾	mA
T _J	Junction Temperature Range		-40	170	°C
¹⁾ as long as T _J max is not exceeded					

3.4.1. Storage and Shelf Life

The permissible storage time (shelf life) of the sensors is unlimited, provided the sensors are stored at a maximum of 30 °C and a maximum of 85% relative humidity. At these conditions, no Dry Pack is required.

Solderability is guaranteed for one year from the date code on the package.

3.5. Recommended Operating Conditions

Functional operation of the device beyond those indicated in the “Recommended Operating Conditions” of this specification is not implied, may result in unpredictable behavior of the device and may reduce reliability and lifetime.

All voltages listed are referenced to ground (GND).

Symbol	Parameter	Pin No.	Min.	Max.	Unit
V_{DD}	Supply Voltage	1	4.3	24	V
I_O	Continuous Output On Current	3	0	20	mA
V_O	Output Voltage (output switched off)	3	0	24	V

3.6. Characteristics

at $T_J = -40\text{ }^\circ\text{C}$ to $+140\text{ }^\circ\text{C}$, $V_{DD} = 4.3\text{ V}$ to 24 V , $GND = 0\text{ V}$,
 at Recommended Operation Conditions if not otherwise specified in the column "Conditions".
 Typical Characteristics for $T_J = 25\text{ }^\circ\text{C}$ and $V_{DD} = 12\text{ V}$.

Symbol	Parameter	Pin No.	Min.	Typ.	Max.	Unit	Conditions
I_{DD}	Supply Current	1	2.3	3	4.2	mA	$T_J = 25\text{ }^\circ\text{C}$
I_{DD}	Supply Current over Temperature Range	1	1.6	3	5.2	mA	
V_{DDZ}	Overshoot Protection at Supply	1	-	28.5	32	V	$I_{DD} = 25\text{ mA}$, $T_J = 25\text{ }^\circ\text{C}$, $t = 20\text{ ms}$
V_{OZ}	Overshoot Protection at Output	3	-	28	32	V	$I_{OH} = 25\text{ mA}$, $T_J = 25\text{ }^\circ\text{C}$, $t = 20\text{ ms}$
V_{OL}	Output Voltage	3	-	130	280	mV	$I_{OL} = 20\text{ mA}$, $T_J = 25\text{ }^\circ\text{C}$
V_{OL}	Output Voltage over Temperature Range	3	-	130	400	mV	$I_{OL} = 20\text{ mA}$
I_{OH}	Output Leakage Current	3	-	0.06	0.1	μA	Output switched off, $T_J = 25\text{ }^\circ\text{C}$, $V_{OH} = 4.3\text{ to }24\text{ V}$
I_{OH}	Output Leakage Current over Temperature Range	3	-	-	10	μA	Output switched off, $T_J \leq 150\text{ }^\circ\text{C}$, $V_{OH} = 4.3\text{ to }24\text{ V}$
f_{osc}	Internal Oscillator Chopper Frequency	-	-	62	-	kHz	$T_J = 25\text{ }^\circ\text{C}$, $V_{DD} = 4.5\text{ to }24\text{ V}$
V_{reset}	Reset Voltage	1	-	3.8	-	V	
$t_{en(O)}$	Enable Time of Output after Setting of V_{DD}	1	-	70	-	μs	$V_{DD} = 12\text{ V}$ ¹⁾
t_r	Output Rise Time	3	-	75	400	ns	$V_{DD} = 12\text{ V}$, $R_L = 820\text{ Ohm}$, $C_L = 20\text{ pF}$
t_f	Output Fall Time	3	-	50	400	ns	
R_{thJSB} case SOT89B-1	Thermal Resistance Junction to Substrate Backside	-	-	150	200	K/W	Fiberglass Substrate 30 mm x 10 mm x 1.5 mm, for pad size see Fig. 3-6
R_{thJA} case TO92UA-1, TO92UA-2	Thermal Resistance Junction to Soldering Point	-	-	150	200	K/W	

¹⁾ $B > B_{ON} + 2\text{ mT}$ or $B < B_{OFF} - 2\text{ mT}$

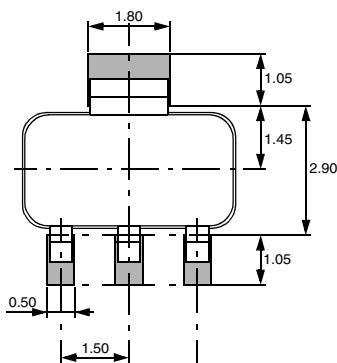

Fig. 3-6: Recommended pad size SOT89B-1
 Dimensions in mm

3.7. Magnetic Characteristics Overview

at $T_J = -40\text{ °C}$ to $+140\text{ °C}$, $V_{DD} = 4.3\text{ V}$ to 24 V , Typical Characteristics for $V_{DD} = 12\text{ V}$

Magnetic flux density values of switching points.

Positive flux density values refer to the magnetic south pole at the branded side of the package.

Sensor Switching Type	Parameter T_J	On point B_{ON}			Off point B_{OFF}			Hysteresis B_{HYS}			Unit
		Min.	Typ.	Max.	Min.	Typ.	Max.	Min.	Typ.	Max.	
HAL542 latching	-40 °C	1	2.8	5	-5	-2.8	-1	4.5	5.85	7.2	mT
	25 °C	1	2.6	4.5	-4.5	-2.6	-1	4.5	5.5	6.5	mT
	140 °C	0.6	2.4	4.6	-4.6	-2.4	-0.6	3.3	4.8	6.2	mT
HAL543 unipolar	-40 °C	21	27	33	15	21	27	4	6	8	mT
	25 °C	21	27	33	15	21	27	4	6	8	mT
	140 °C	21	27	33	15	21	27	4	5.5	8	mT
HAL546 unipolar	-40 °C	4.3	5.9	7.7	2.1	3.8	5.5	1.5	2.1	2.9	mT
	25 °C	3.8	5.5	7.2	2	3.5	5	1.4	2	2.8	mT
	140 °C	3.2	4.8	6.9	1.8	3.1	5.5	1	1.7	2.6	mT
HAL548 unipolar	-40 °C	12	19	24	6	13	18	4	6	8	mT
	25 °C	12	18	24	6	12	18	4	6	8	mT
	140 °C	12	17	24	6	11	18	4	6	8	mT

Note: For detailed descriptions of the individual types, see pages 19 and following.

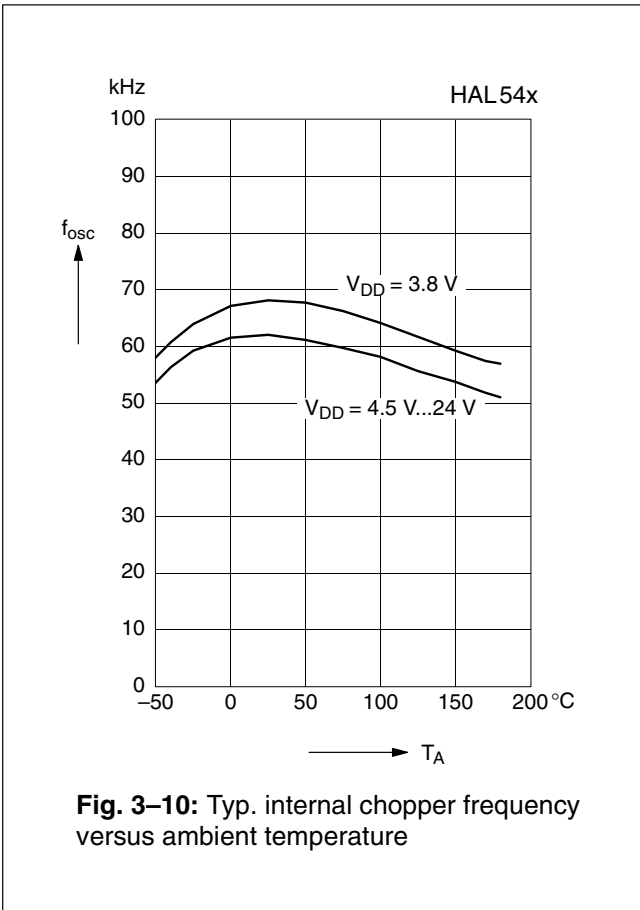
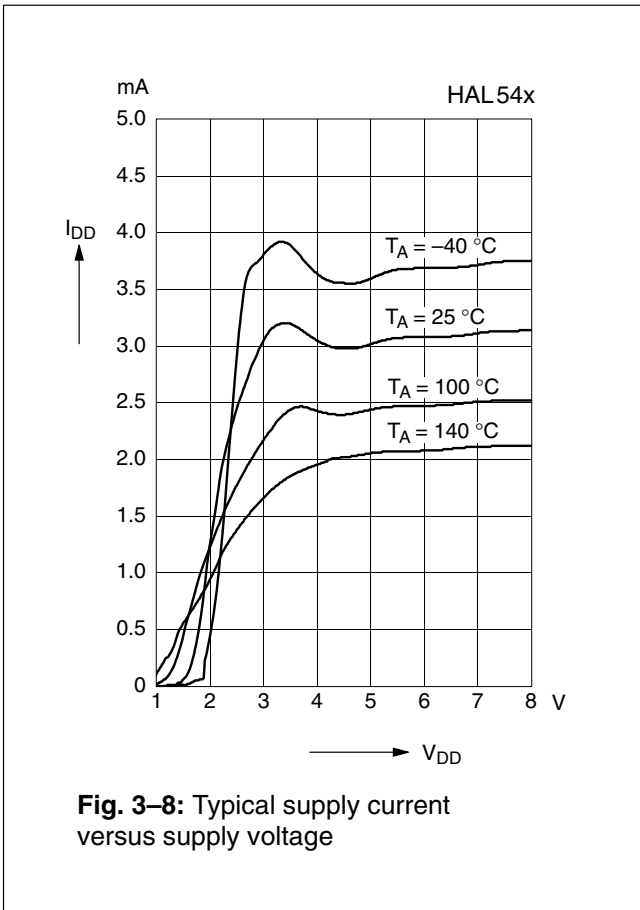
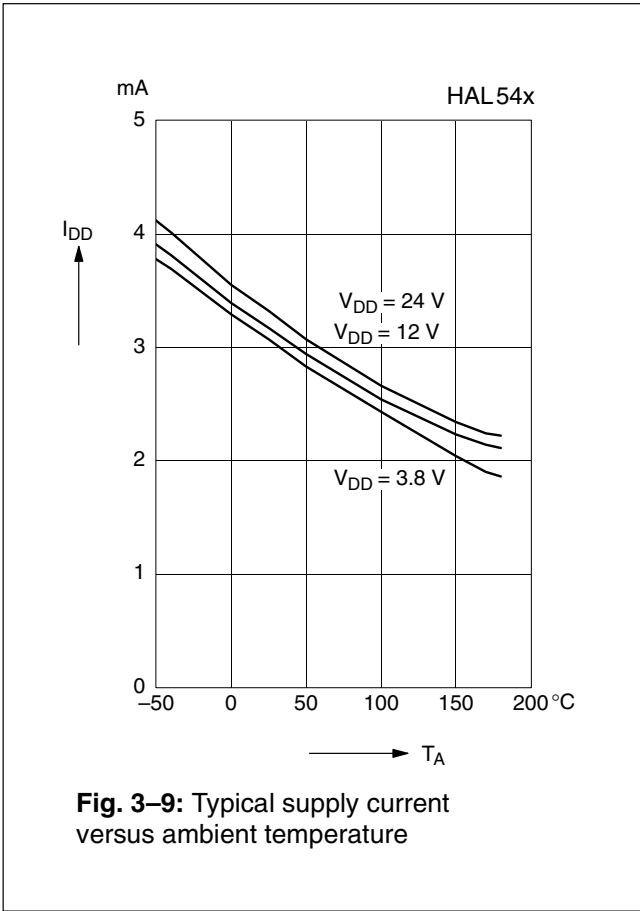
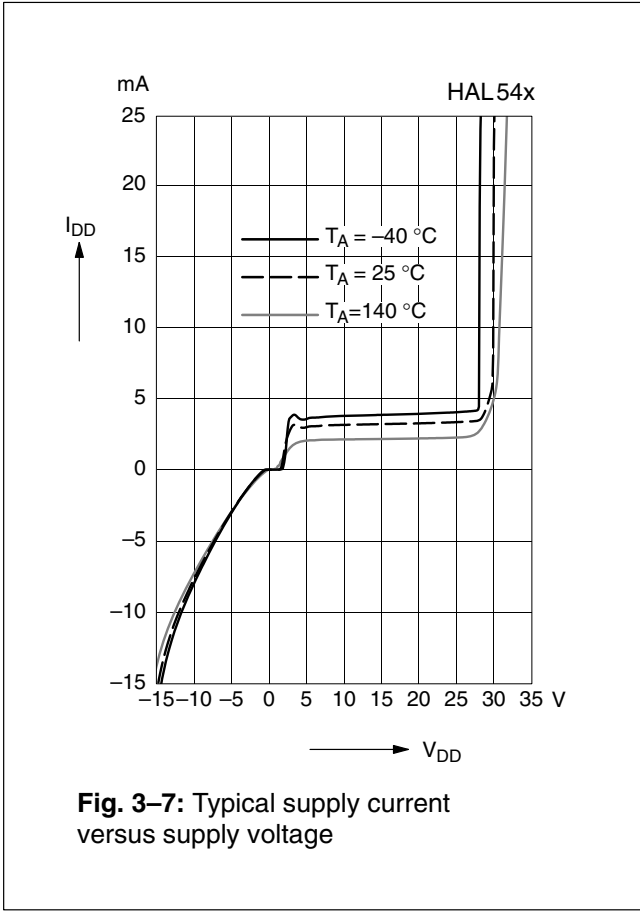

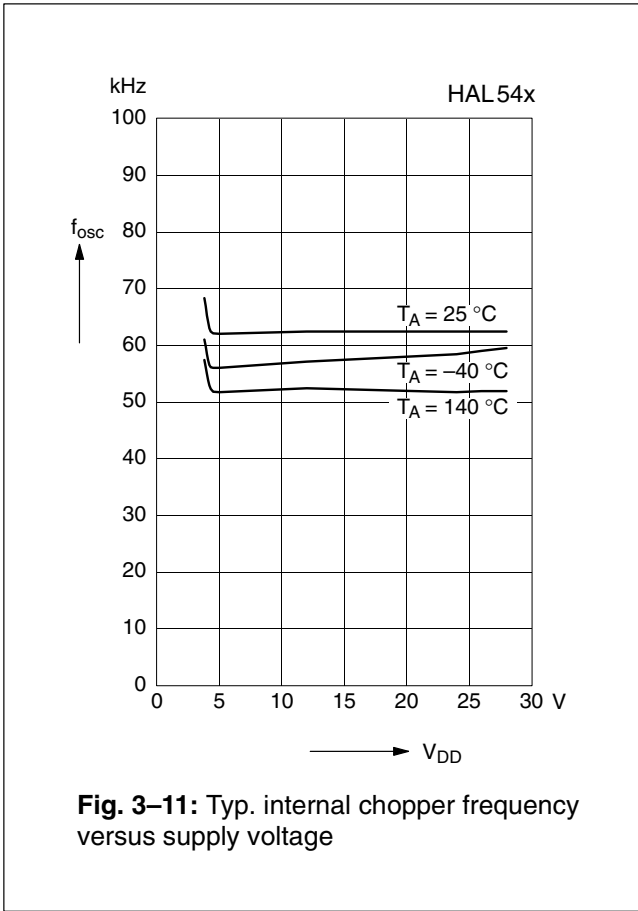

Fig. 3-11: Typ. internal chopper frequency versus supply voltage

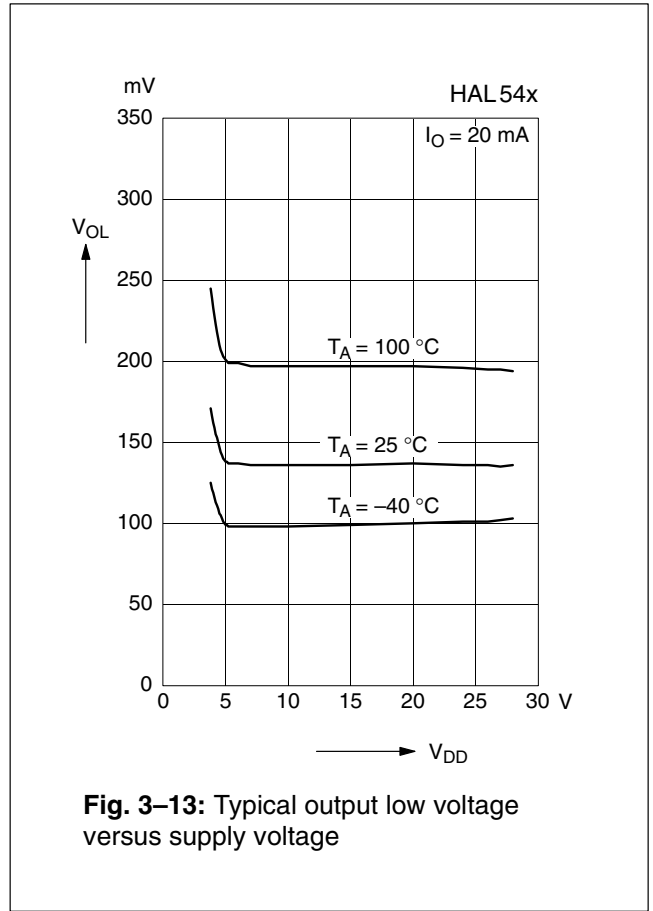

Fig. 3-13: Typical output low voltage versus supply voltage

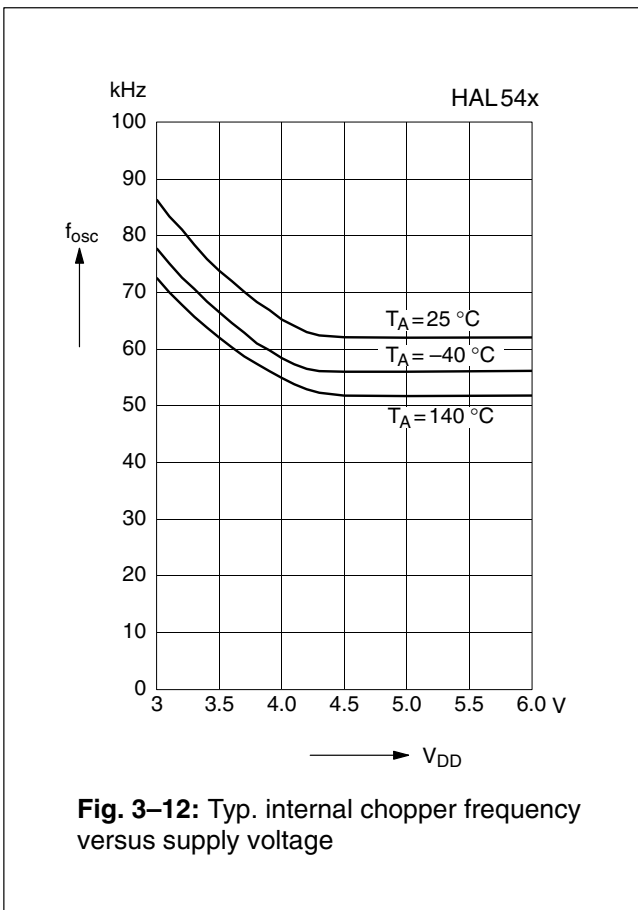

Fig. 3-12: Typ. internal chopper frequency versus supply voltage

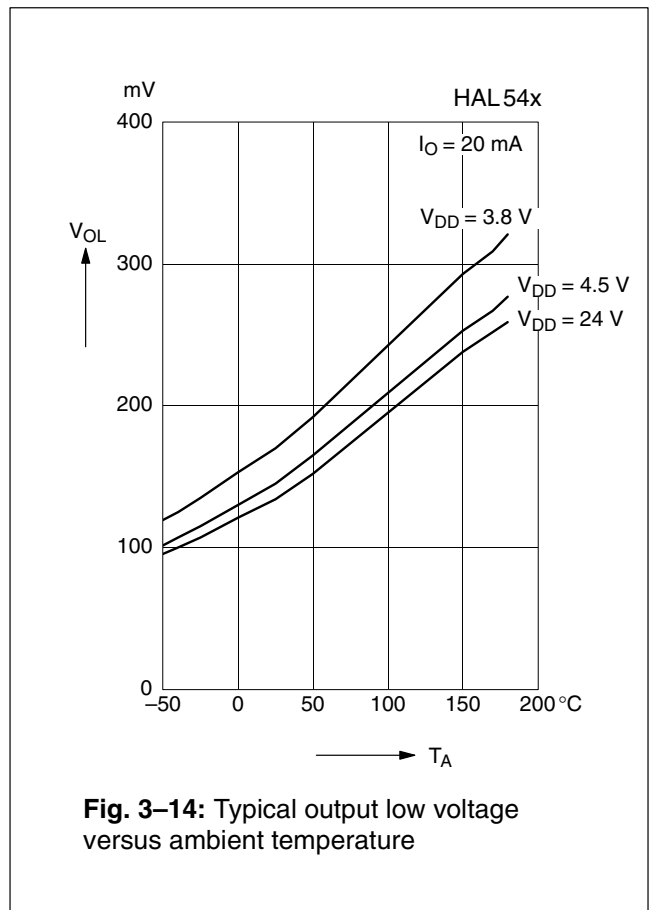
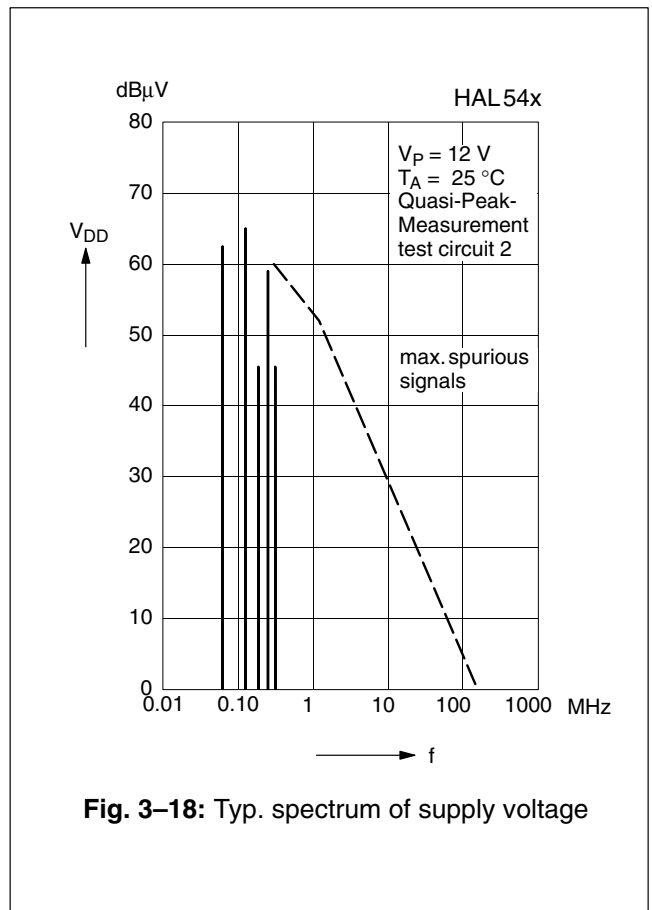
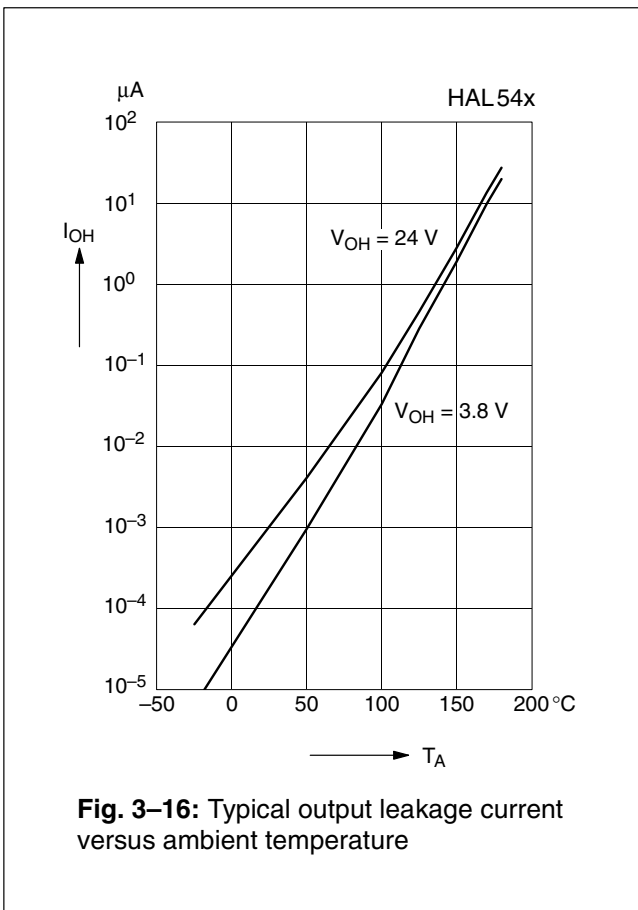
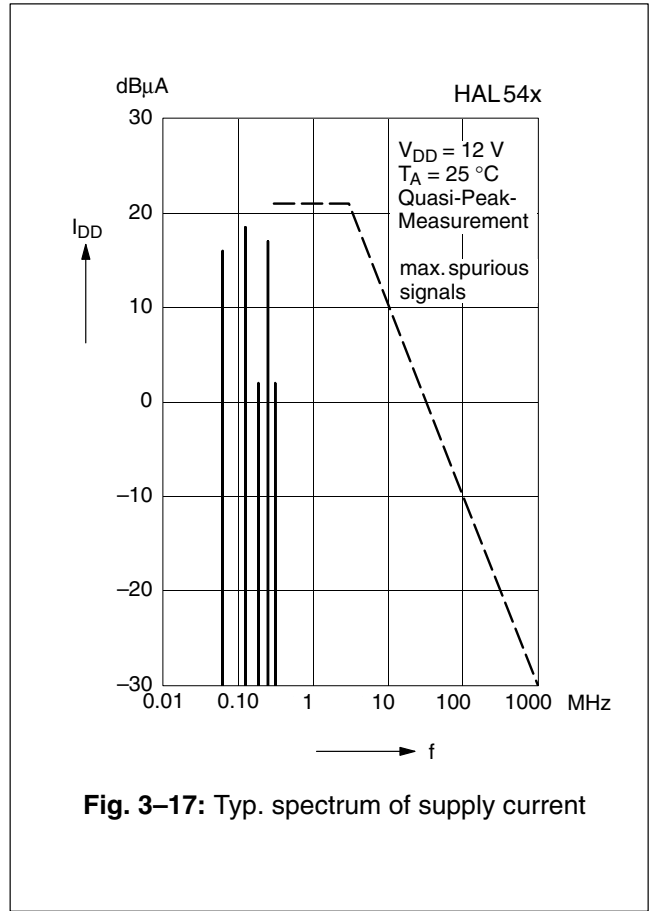
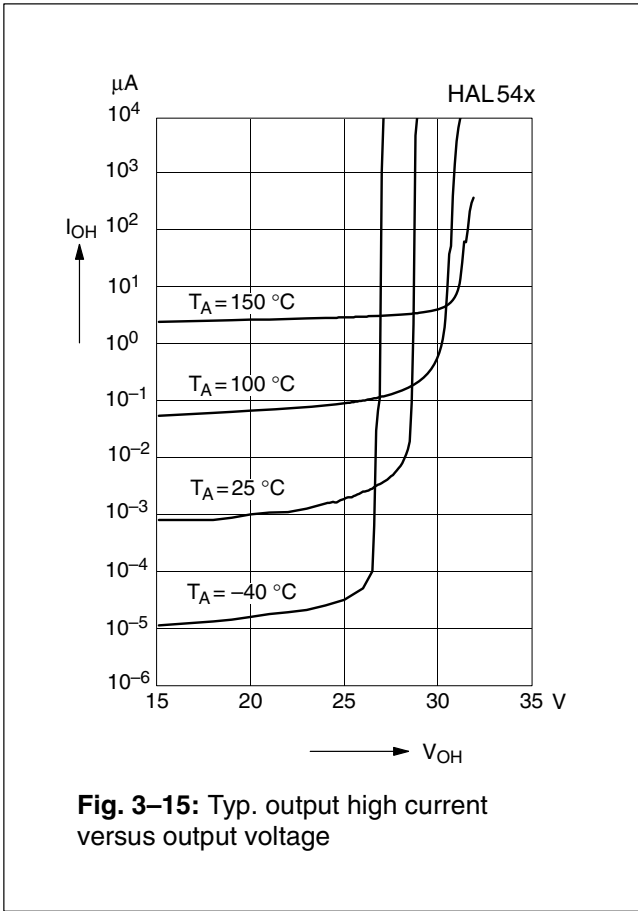

Fig. 3-14: Typical output low voltage versus ambient temperature



4. Type Description

4.1. HAL542

The HAL542 is the most sensitive latching sensor of this family (see Fig. 4–1).

The output turns low with the magnetic south pole on the branded side of the package and turns high with the magnetic north pole on the branded side. The output does not change if the magnetic field is removed. For changing the output state, the opposite magnetic field polarity must be applied.

For correct functioning in the application, the sensor requires both magnetic polarities (north and south) on the branded side of the package.

Magnetic Features:

- switching type: latching
- high sensitivity
- typical B_{ON} : 2.6 mT at room temperature
- typical B_{OFF} : -2.6 mT at room temperature
- operates with static magnetic fields and dynamic magnetic fields up to 10 kHz
- typical temperature coefficient of magnetic switching points is -1000 ppm/K

Applications

The HAL542 is the optimal sensor for applications with alternating magnetic signals and weak magnetic amplitude at the sensor position such as:

- applications with large air gap or weak magnets,
- rotating speed measurement,
- commutation of brushless DC motors, and
- CAM shaft sensors, and
- magnetic encoders.

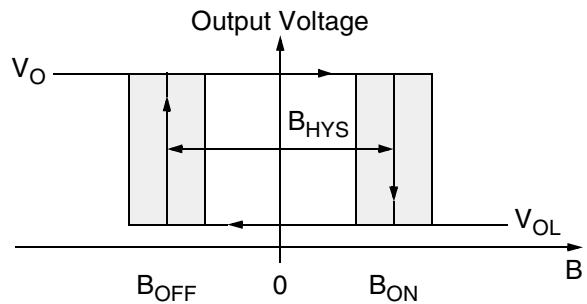

Fig. 4–1: Definition of magnetic switching points for the HAL542

Magnetic Characteristics at $T_J = -40\text{ °C}$ to $+140\text{ °C}$, $V_{DD} = 4.3\text{ V}$ to 24 V , Typical Characteristics for $V_{DD} = 12\text{ V}$

Magnetic flux density values of switching points. Positive flux density values refer to the magnetic south pole at the branded side of the package.

Parameter T_J	On point B_{ON}			Off point B_{OFF}			Hysteresis B_{HYS}			Magnetic Offset			Unit
	Min.	Typ.	Max.	Min.	Typ.	Max.	Min.	Typ.	Max.	Min.	Typ.	Max.	
-40 °C	1	2.8	5	-5	-2.8	-1	4.5	5.85	7.2		0		mT
25 °C	1	2.6	4.5	-4.5	-2.6	-1	4.5	5.5	6.5	-1.5	0	1.5	mT
100 °C	0.95	2.5	4.4	-4.4	-2.5	-0.95	3.7	5.0	6.3		0		mT
140 °C	0.6	2.4	4.6	-4.6	-2.4	-0.6	3.3	4.8	6.2		0		mT

The hysteresis is the difference between the switching points $B_{HYS} = B_{ON} - B_{OFF}$
 The magnetic offset is the mean value of the switching points $B_{OFFSET} = (B_{ON} + B_{OFF}) / 2$

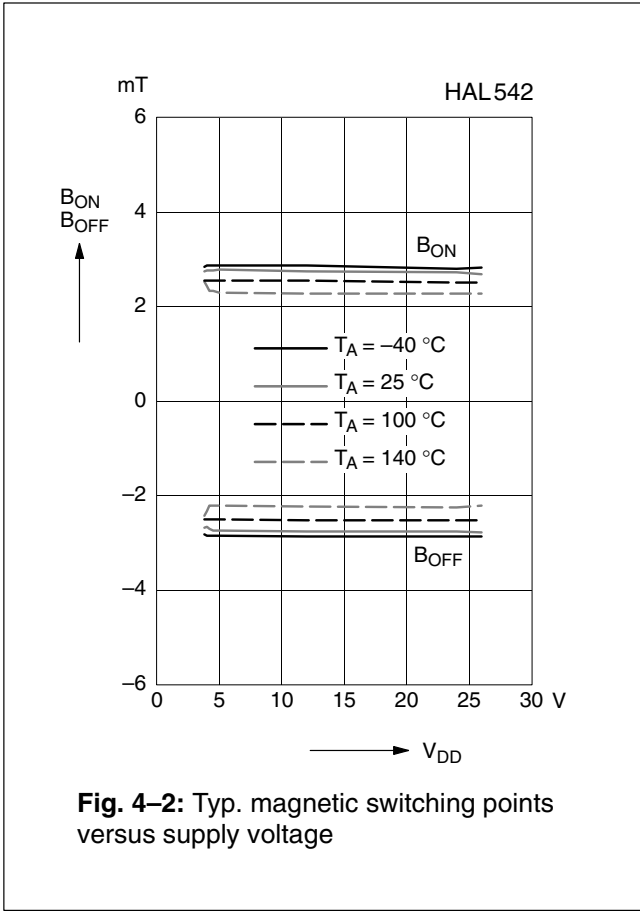

Fig. 4-2: Typ. magnetic switching points versus supply voltage

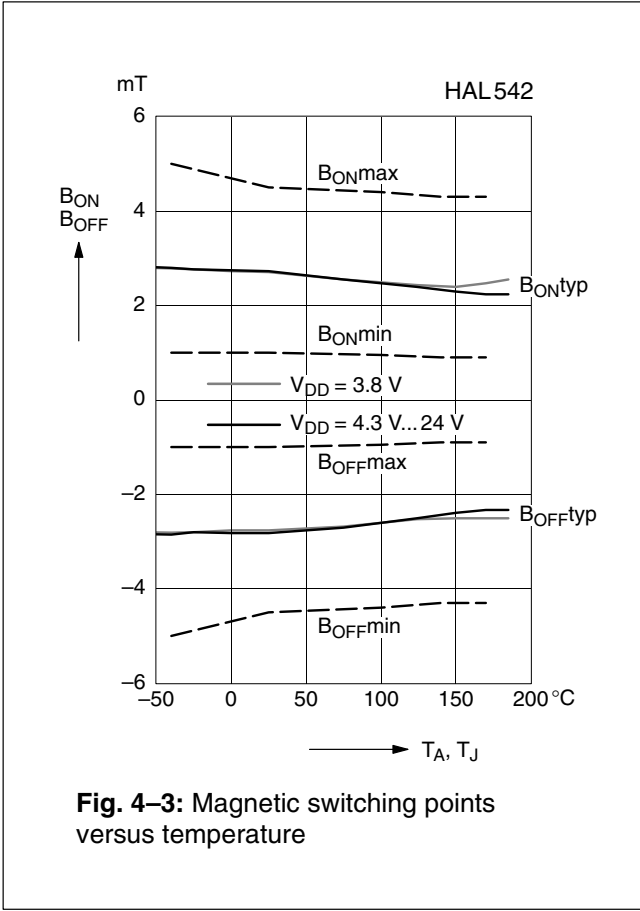

Fig. 4-3: Magnetic switching points versus temperature

Note: In the diagram “Magnetic switching points versus ambient temperature”, the curves for B_{ONmin} , B_{ONmax} , B_{OFFmin} , and B_{OFFmax} refer to junction temperature, whereas typical curves refer to ambient temperature.

4.2. HAL543

The HAL543 is the most insensitive unipolar sensor of this family (see Fig. 4–4).

The output turns low with the magnetic south pole on the branded side of the package and turns high if the magnetic field is removed. The sensor does not respond to the magnetic north pole on the branded side.

Magnetic Features:

- switching type: unipolar
- low sensitivity
- typical B_{ON} : 27 mT at room temperature
- typical B_{OFF} : 21 mT at room temperature
- operates with static magnetic fields and dynamic magnetic fields up to 10 kHz
- points is –1000 ppm/K

Applications

The HAL543 is the optimal sensor for applications with unipolar magnetic signals and large magnetic amplitude at the sensor position such as:

- position and end-point detection,
- contactless solution to replace microswitches,
- rotating speed measurement.

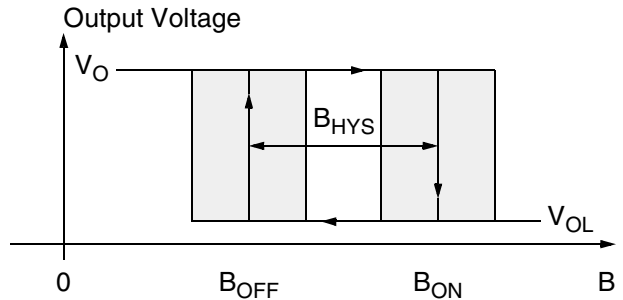

Fig. 4–4: Definition of magnetic switching points for the HAL543

Magnetic Characteristics at $T_J = -40\text{ °C}$ to $+140\text{ °C}$, $V_{DD} = 4.3\text{V}$ to 24 V , Typical Characteristics for $V_{DD} = 12\text{ V}$

Magnetic flux density values of switching points.

Positive flux density values refer to the magnetic south pole at the branded side of the package.

Parameter T_J	On point B_{ON}			Off point B_{OFF}			Hysteresis B_{HYS}			Magnetic Offset			Unit
	Min.	Typ.	Max.	Min.	Typ.	Max.	Min.	Typ.	Max.	Min.	Typ.	Max.	
-40 °C	21	27	33	15	21	27	4	6	8	–	24	–	mT
25 °C	21	27	33	15	21	27	4	6	8	18	24	30	mT
100 °C	21	27	33	15	21	27	4	6	8	–	24	–	mT
140 °C	21	27	33	15	21	27	4	5.5	8	–	24	–	mT

The hysteresis is the difference between the switching points $B_{HYS} = B_{ON} - B_{OFF}$
 The magnetic offset is the mean value of the switching points $B_{OFFSET} = (B_{ON} + B_{OFF}) / 2$

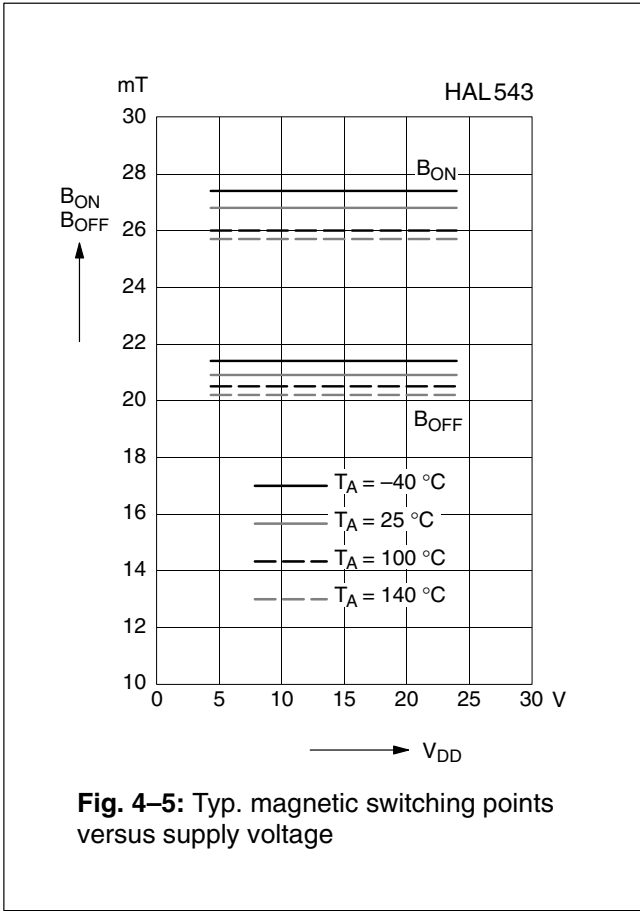

Fig. 4-5: Typ. magnetic switching points versus supply voltage

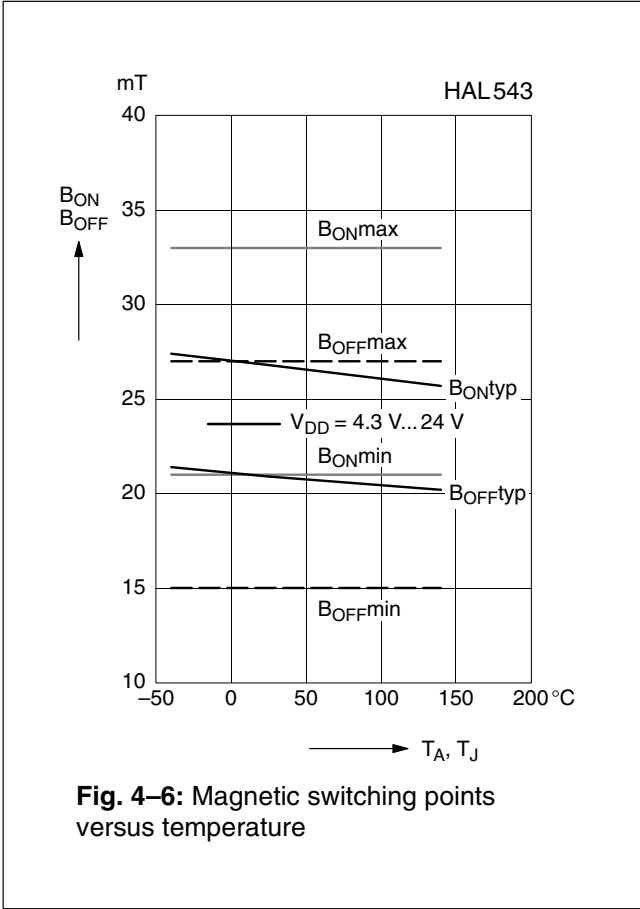

Fig. 4-6: Magnetic switching points versus temperature

Note: In the diagram “Magnetic switching points versus ambient temperature”, the curves for B_{ONmin} , B_{ONmax} , B_{OFFmin} , and B_{OFFmax} refer to junction temperature, whereas typical curves refer to ambient temperature.

4.3. HAL546

The HAL546 is a quite sensitive unipolar sensor (see Fig. 4–7).

The output turns low with the magnetic south pole on the branded side of the package and turns high if the magnetic field is removed. The sensor does not respond to the magnetic north pole on the branded side.

Magnetic Features:

- switching type: unipolar
- high sensitivity
- typical B_{ON} : 5.5 mT at room temperature
- typical B_{OFF} : 3.5 mT at room temperature
- operates with static magnetic fields and dynamic magnetic fields up to 10 kHz
- typical temperature coefficient of magnetic switching points is -1000 ppm/K.

Applications

The HAL546 is the optimal sensor for applications with one magnetic polarity such as:

- solid state switches,
- contactless solution to replace micro-switches, and
- rotating speed measurement.

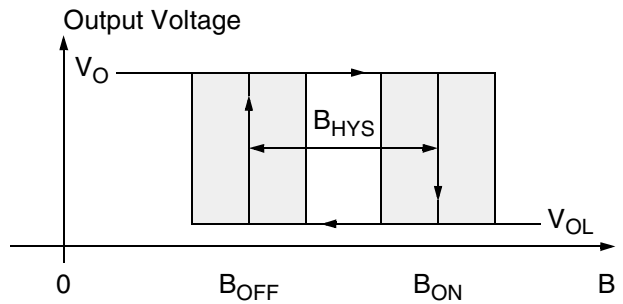

Fig. 4–7: Definition of magnetic switching points for the HAL546

Magnetic Characteristics at $T_J = -40\text{ }^\circ\text{C}$ to $+140\text{ }^\circ\text{C}$, $V_{DD} = 4.3\text{ V}$ to 24 V , Typical Characteristics for $V_{DD} = 12\text{ V}$

Magnetic flux density values of switching points.

Positive flux density values refer to the magnetic south pole at the branded side of the package.

Parameter T_J	On point B_{ON}			Off point B_{OFF}			Hysteresis B_{HYS}			Magnetic Offset			Unit
	Min.	Typ.	Max.	Min.	Typ.	Max.	Min.	Typ.	Max.	Min.	Typ.	Max.	
$-40\text{ }^\circ\text{C}$	4.3	5.9	7.7	2.1	3.8	5.5	1.5	2.1	2.9	–	4.9	–	mT
$25\text{ }^\circ\text{C}$	3.8	5.5	7.2	2	3.5	5	1.4	2	2.8	2.9	4.5	6.1	mT
$100\text{ }^\circ\text{C}$	3.5	5.3	7	1.9	3.3	5.4	1.1	1.9	2.6	–	4.3	–	mT
$140\text{ }^\circ\text{C}$	3.2	4.8	6.9	1.8	3.1	5.5	1	1.7	2.6	–	4	–	mT

The hysteresis is the difference between the switching points $B_{HYS} = B_{ON} - B_{OFF}$

The magnetic offset is the mean value of the switching points $B_{OFFSET} = (B_{ON} + B_{OFF}) / 2$

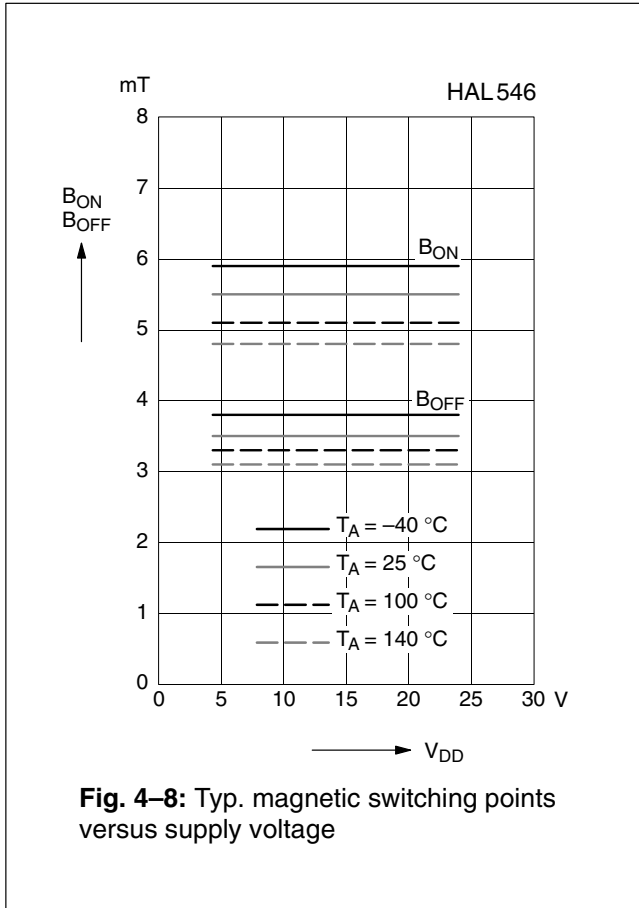

Fig. 4–8: Typ. magnetic switching points versus supply voltage

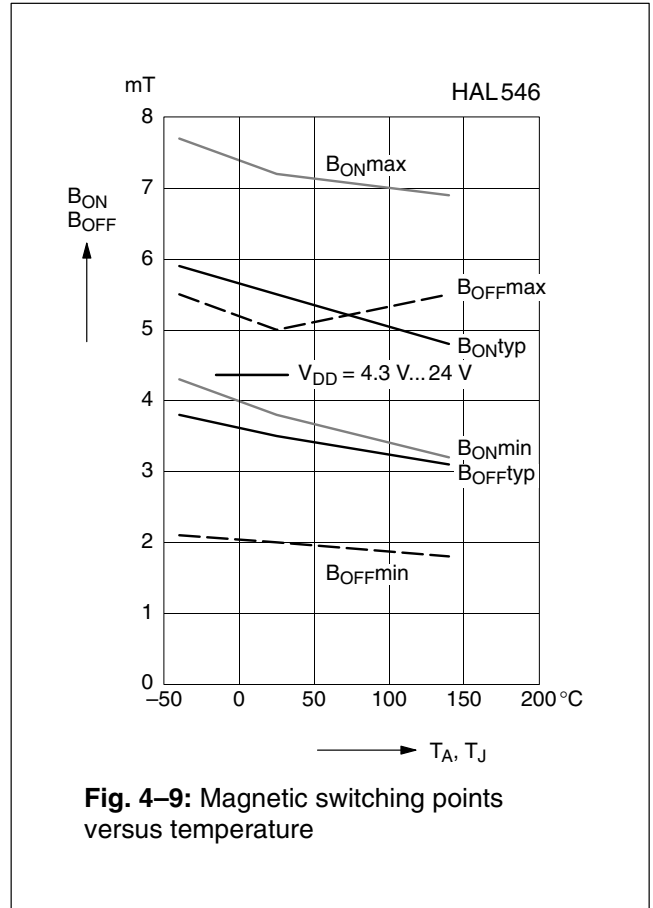

Fig. 4–9: Magnetic switching points versus temperature

Note: In the diagram “Magnetic switching points versus ambient temperature”, the curves for B_{ONmin} , B_{ONmax} , B_{OFFmin} , and B_{OFFmax} refer to junction temperature, whereas typical curves refer to ambient temperature.

4.4. HAL548

The HAL548 is a unipolar switching sensor (see Fig. 4–10).

The output turns low with the magnetic south pole on the branded side of the package and turns high if the magnetic field is removed. The sensor does not respond to the magnetic north pole on the branded side.

Magnetic Features:

- switching type: unipolar,
- medium sensitivity
- typical B_{ON} : 18 mT at room temperature
- typical B_{OFF} : 12 mT at room temperature
- operates with static magnetic fields and dynamic magnetic fields up to 10 kHz

Applications

The HAL548 is the ideal sensor for all applications with one magnetic polarity and weak magnetic amplitude at the sensor position such as:

- solid state switches,
- contactless solution to replace micro switches,
- position and end point detection, and
- rotating speed measurement.

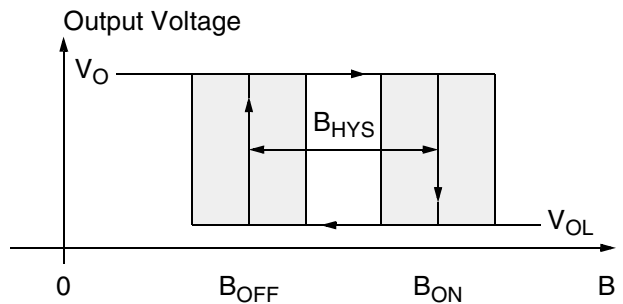

Fig. 4–10: Definition of magnetic switching points for the HAL548

Magnetic Characteristics at $T_J = -40\text{ °C}$ to $+140\text{ °C}$, $V_{DD} = 4.3\text{ V}$ to 24 V , Typical Characteristics for $V_{DD} = 12\text{ V}$

Magnetic flux density values of switching points. Positive flux density values refer to the magnetic south pole at the branded side of the package.

Parameter T_J	On point B_{ON}			Off point B_{OFF}			Hysteresis B_{HYS}			Magnetic Offset			Unit
	Min.	Typ.	Max.	Min.	Typ.	Max.	Min.	Typ.	Max.	Min.	Typ.	Max.	
-40 °C	12	19	24	6	13	18	4	6	8	–	16	–	mT
25 °C	12	18	24	6	12	18	4	6	8	9	15	21	mT
100 °C	12	18	24	6	12	18	4	6	8	–	15	–	mT
140 °C	12	17	24	6	11	18	4	6	8	–	14	–	mT

The hysteresis is the difference between the switching points $B_{HYS} = B_{ON} - B_{OFF}$
 The magnetic offset is the mean value of the switching points $B_{OFFSET} = (B_{ON} + B_{OFF}) / 2$

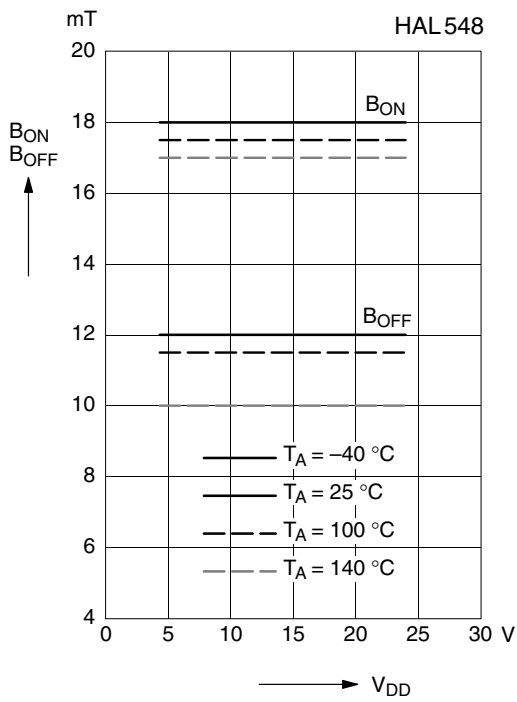

Fig. 4-11: Typ. magnetic switching points versus supply voltage

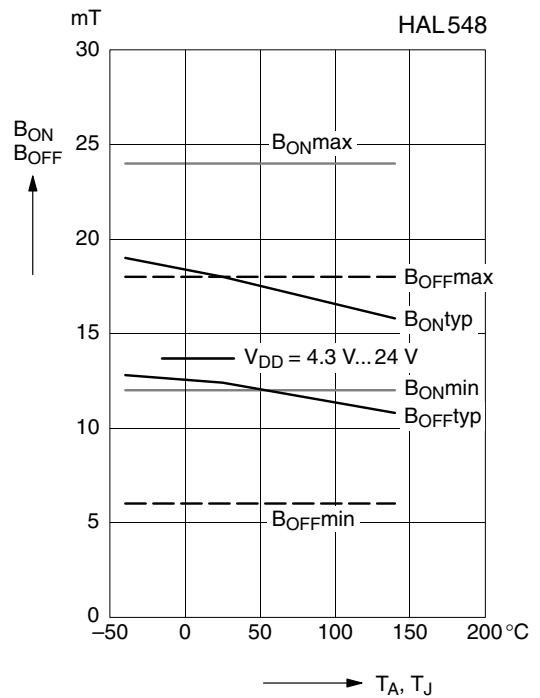

Fig. 4-12: Magnetic switching points versus temperature

Note: In the diagram “Magnetic switching points versus ambient temperature”, the curves for B_{ONmin} , B_{ONmax} , B_{OFFmin} , and B_{OFFmax} refer to junction temperature, whereas typical curves refer to ambient temperature.

5. Application Notes

5.1. Ambient Temperature

Due to the internal power dissipation, the temperature on the silicon chip (junction temperature T_J) is higher than the temperature outside the package (ambient temperature T_A).

$$T_J = T_A + \Delta T$$

At static conditions and continuous operation, the following equation applies:

$$\Delta T = I_{DD} \times V_{DD} \times R_{th}$$

For typical values, use the typical parameters. For worst case calculation, use the max. parameters for I_{DD} and R_{th} , and the max. value for V_{DD} from the application.

For all sensors, the junction temperature range T_J is specified. The maximum ambient temperature T_{Amax} can be calculated as:

$$T_{Amax} = T_{Jmax} - \Delta T$$

5.2. Extended Operating Conditions

All sensors fulfill the electrical and magnetic characteristics when operated within the Recommended Operating Conditions (see page 13).

Supply Voltage Below 4.3 V

The devices contain a Power-on Reset (POR) and an undervoltage reset. For $V_{DD} < V_{reset}$ the output state is high. For $V_{reset} < V_{DD} < 4.3$ V the device responds to the magnetic field according to the specified magnetic characteristics.

Note: The functionality of the sensor below 4.3 V is not tested. For special test conditions, please contact Micronas.

5.3. Start-up Behavior

Due to the active offset compensation, the sensors have an initialization time (enable time $t_{en(O)}$) after applying the supply voltage. The parameter $t_{en(O)}$ is specified in the characteristics table (see page 14).

During the initialization time, the output state for the HAL54x is “Off-state” (i.e. Output High). After $t_{en(O)}$, the output will be high. The output will be switched to low if the applied magnetic field B is above B_{ON} .

5.4. EMC and ESD

For applications with disturbances on the supply line or radiated disturbances, a series resistor and a capacitor are recommended (see Fig. 5–1). The series resistor and the capacitor should be placed as closely as possible to the Hall sensor.

Please contact Micronas for the detailed investigation reports with the EMC and ESD results.

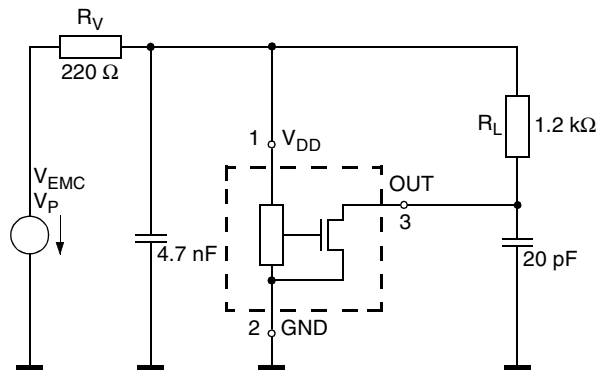

Fig. 5–1: Test circuit for EMC investigations

6. Data Sheet History

1. Data sheet: "HAL54x Hall Effect Sensor Family", Nov. 27, 2002, 6251-605-1DS. First release of the data sheet.
2. Data Sheet: "HAL54x Hall-Effect Sensor Family", Sept. 13, 2004, DSH000023_001EN. Second release of the data sheet. Major changes:
 - new package diagrams for SOT89B-1 and TO92UA-1
 - package diagram for TO92UA-2 added
 - ammpack diagrams for TO92UA-1/-2 added
3. Data Sheet: "HAL54x Hall-Effect Sensor Family", Dec. 5, 2008, DSH000023_002EN. Third release of the data sheet. Major changes:
 - Section 1.6. on page 5 "Solderability and Welding" updated.
 - Fig. 3–6: Recommended footprint SOT89-B1 added
 - all package diagrams updated.
4. Data Sheet: "HAL54x Hall-Effect Sensor Family", Feb. 12, 2009, DSH000023_003EN. Fourth release of the data sheet. Minor changes:
 - Section 3.3. "Positions of Sensitive Areas" updated (parameter A4 for SOT89-B1 was added).