

# Data Sheet

## **HAL<sup>®</sup> 300**

Differential Hall Effect  
Sensor IC

---

**Copyright, Warranty, and Limitation of Liability**

The information and data contained in this document are believed to be accurate and reliable. The software and proprietary information contained therein may be protected by copyright, patent, trademark and/or other intellectual property rights of Micronas. All rights not expressly granted remain reserved by Micronas.

Micronas assumes no liability for errors and gives no warranty representation or guarantee regarding the suitability of its products for any particular purpose due to these specifications.

By this publication, Micronas does not assume responsibility for patent infringements or other rights of third parties which may result from its use. Commercial conditions, product availability and delivery are exclusively subject to the respective order confirmation.

Any information and data which may be provided in the document can and do vary in different applications, and actual performance may vary over time.

All operating parameters must be validated for each customer application by customers technical experts. Any new issue of this document invalidates previous issues. Micronas reserves the right to review this document and to make changes to the documents content at any time without obligation to notify any person or entity of such revision or changes. For further advice please contact us directly.

Do not use our products in life-supporting systems, aviation and aerospace applications! Unless explicitly agreed to otherwise in writing between the parties, Micronas products are not designed, intended or authorized for use as components in systems intended for surgical implants into the body, or other applications intended to support or sustain life, or for any other application in which the failure of the product could create a situation where personal injury or death could occur.

No part of this publication may be reproduced, photocopied, stored on a retrieval system or transmitted without the express written consent of Micronas.

**Micronas Trademarks**

– HAL

**Micronas Patents**

Choppered Offset Compensation protected by Micronas patents no. US5260614A, US5406202A, EP052523B1, and EP0548391B1.

**Third-Party Trademarks**

All other brand and product names or company names may be trademarks of their respective companies.

---

**Contents**

<b>Page</b>	<b>Section</b>	<b>Title</b>
<b>4</b>	<b>1.</b>	<b>Introduction</b>
4	1.1.	Features
4	1.2.	Marking Code
4	1.3.	Operating Junction Temperature Range
5	1.4.	Hall Sensor Package Codes
5	1.5.	Solderability and Welding
5	1.6.	Pin Connections
<b>6</b>	<b>2.</b>	<b>Functional Description</b>
<b>7</b>	<b>3.</b>	<b>Specifications</b>
7	3.1.	Outline Dimensions
12	3.2.	Dimensions of Sensitive Area
12	3.3.	Positions of Sensitive Areas
12	3.4.	Absolute Maximum Ratings
12	3.4.1.	Storage and Shelf Life
13	3.5.	Recommended Operating Conditions
14	3.6.	Characteristics
15	3.7.	Magnetic Characteristics
<b>20</b>	<b>4.</b>	<b>Application Notes</b>
20	4.1.	Ambient Temperature
20	4.2.	Extended Operating Conditions
20	4.3.	Start-up Behavior
21	4.4.	EMC and ESD
<b>22</b>	<b>5.</b>	<b>Data Sheet History</b>

**Differential Hall Effect Sensor IC**  
in CMOS technology

**Release Notes: Revision bars indicate significant changes to the previous edition.**

**1. Introduction**

The HAL300 is a differential Hall switch produced in CMOS technology. The sensor includes 2 temperature-compensated Hall plates (2.05 mm apart) with active offset compensation, a differential amplifier with a Schmitt trigger, and an open-drain output transistor (see Fig. 2-1).

The HAL300 is a differential sensor which responds to spatial differences of the magnetic field. The Hall voltages at the two Hall plates,  $S_1$  and  $S_2$ , are amplified with a differential amplifier. The differential signal is compared with the actual switching level of the internal Schmitt trigger. Accordingly, the output transistor is switched on or off.

The sensor has a bipolar switching behavior and requires positive and negative values of  $\Delta B = B_{S1} - B_{S2}$  for correct operation.

The HAL300 is an ideal sensor for applications with a rotating multi-pole-ring in front of the branded side of the package (see Fig. 3-1, Fig. 3-2 and Fig. 3-3), such as ignition timing and revolution counting.

For applications in which a magnet is mounted on the back side of the package (back-biased applications), the HAL320 is recommended.

The active offset compensation leads to constant magnetic characteristics over supply voltage and temperature.

The sensor is designed for industrial and automotive applications and operates with supply voltages from 4.5 V to 24 V in the ambient temperature range from -40 °C up to 150 °C.

The HAL300 is available in the SMD-package SOT89B-2 and in the leaded versions TO92UA-3 and TO92UA-4.

**1.1. Features:**

- distance between Hall plates: 2.05 mm
- operates from 4.5 V to 24 V supply voltage
- switching offset compensation at 62 kHz
- overvoltage protection
- reverse-voltage protection at  $V_{DD}$ -pin
- short-circuit protected open-drain output by thermal shutdown
- operates with magnetic fields from DC to 10 kHz
- output turns low with magnetic south pole on branded side of package and with a higher magnetic flux density in sensitive area  $S_1$  as in  $S_2$
- on-chip temperature compensation circuitry minimizes shifts of the magnetic parameters over temperature and supply voltage range
- the decrease of magnetic flux density caused by rising temperature in the sensor system is compensated by a built-in negative temperature coefficient of hysteresis
- EMC corresponding to ISO 7637

**1.2. Marking Code**

Type	Temperature Range	
	A	K
HAL300	300A	300K

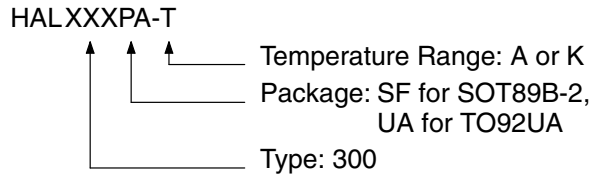
**1.3. Operating Junction Temperature Range ( $T_J$ )**

**A:**  $T_J = -40\text{ °C to }+170\text{ °C}$

**K:**  $T_J = -40\text{ °C to }+140\text{ °C}$

The relationship between ambient temperature ( $T_A$ ) and junction temperature ( $T_J$ ) is explained in section 4.1. on page 20.

### 1.4. Hall Sensor Package Codes



Example: **HAL 300UA-K**

- Type: 300
- Package: TO92UA
- Temperature Range:  $T_J = -40\text{ °C to }+140\text{ °C}$

Hall sensors are available in a wide variety of packaging versions and quantities. For more detailed information, please refer to the brochure: “Hall Sensors: Ordering Codes, Packaging, Handling”.

### 1.5. Solderability and Welding

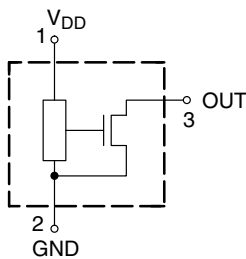
#### Soldering

During soldering reflow processing and manual reworking, a component body temperature of 260 °C should not be exceeded.

#### Welding

Device terminals should be compatible with laser and resistance welding. Please note that the success of the welding process is subject to different welding parameters which will vary according to the welding technique used. A very close control of the welding parameters is absolutely necessary in order to reach satisfying results. Micronas, therefore, does not give any implied or express warranty as to the ability to weld the component.

### 1.6. Pin Connections



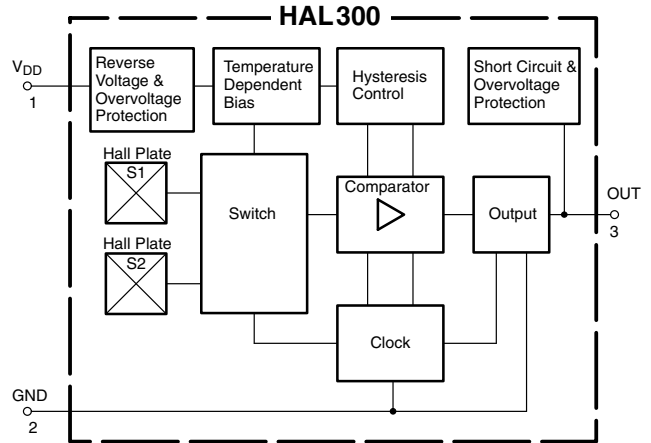
**Fig. 1-1:** Pin configuration

**2. Functional Description**

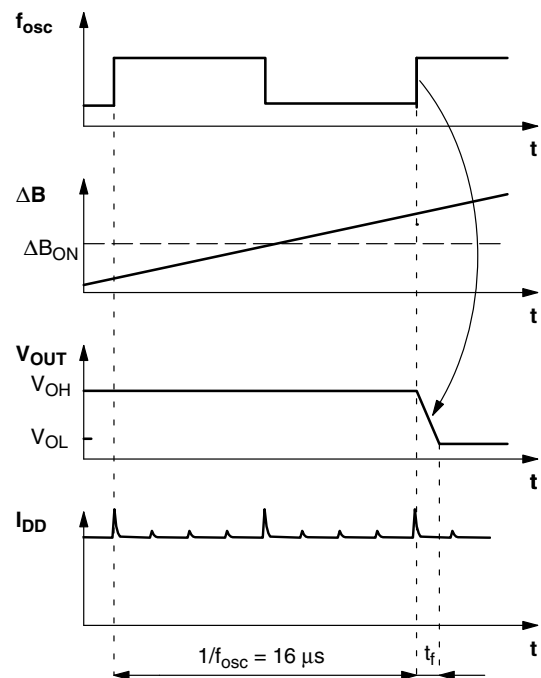
This Hall effect sensor is a monolithic integrated circuit with 2 Hall plates 2.05 mm apart that switches in response to differential magnetic fields. If magnetic fields with flux lines perpendicular to the sensitive areas are applied to the sensor, the biased Hall plates force Hall voltages proportional to these fields. The difference of the Hall voltages is compared with the actual threshold level in the comparator. The temperature-dependent bias increases the supply voltage of the Hall plates and adjusts the switching points to the decreasing induction of magnets at higher temperatures. If the differential magnetic field exceeds the threshold levels, the open drain output switches to the appropriate state. The built-in hysteresis eliminates oscillation and provides switching behavior of the output without oscillation.

Magnetic offset caused by mechanical stress at the Hall plates is compensated for by using the “switching offset compensation technique”: An internal oscillator provides a two phase clock (see Fig. 2–2). The difference of the Hall voltages is sampled at the end of the first phase. At the end of the second phase, both sampled differential Hall voltages are averaged and compared with the actual switching point. Subsequently, the open drain output switches to the appropriate state. The amount of time that elapses from crossing the magnetic switch level to the actual switching of the output can vary between zero and  $1/f_{osc}$ .

Shunt protection devices clamp voltage peaks at the Output-Pin and  $V_{DD}$ -Pin together with external series resistors. Reverse current is limited at the  $V_{DD}$ -Pin by an internal series resistor up to  $-15\text{ V}$ . No external reverse protection diode is needed at the  $V_{DD}$ -Pin for values ranging from  $0\text{ V}$  to  $-15\text{ V}$ .



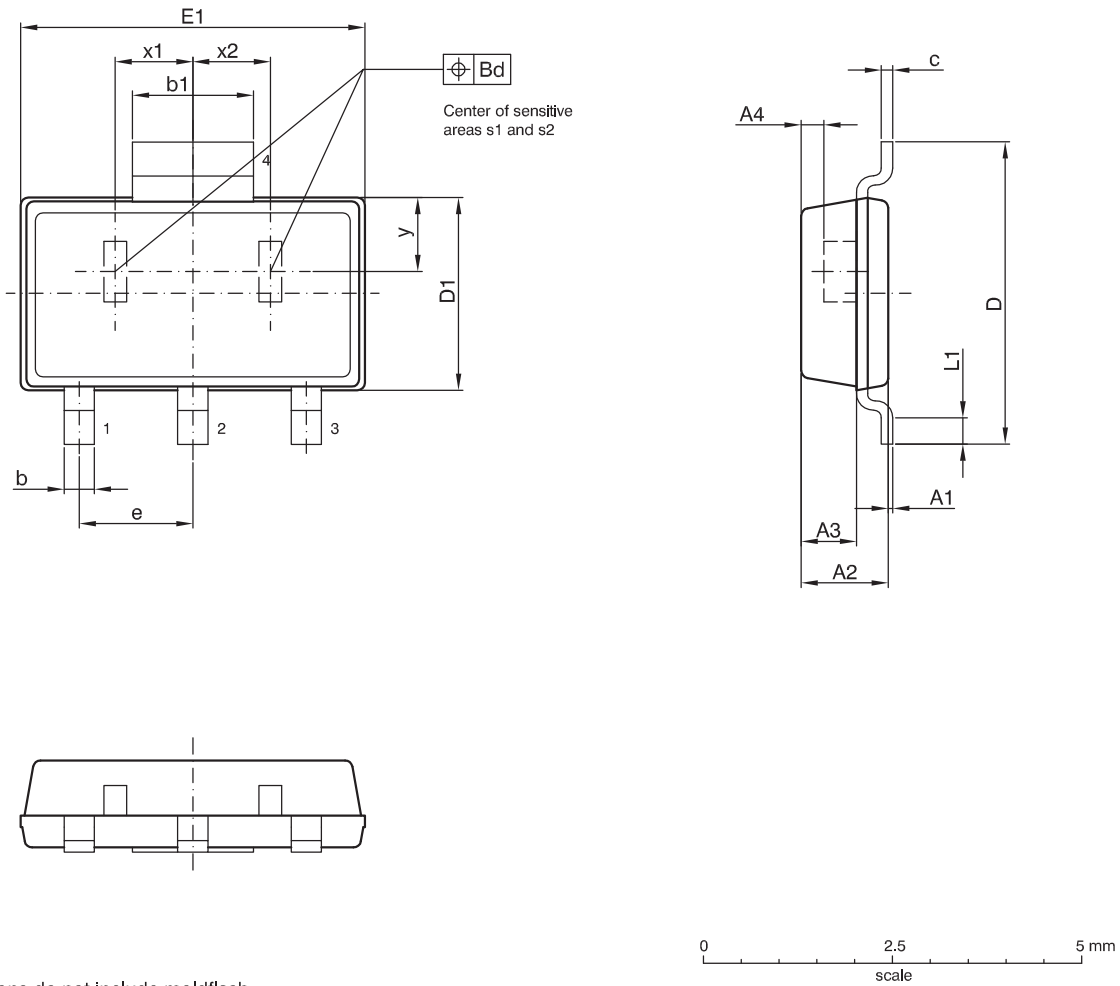
**Fig. 2–1:** HAL300 block diagram



**Fig. 2–2:** Timing diagram

3. Specifications

3.1. Outline Dimensions



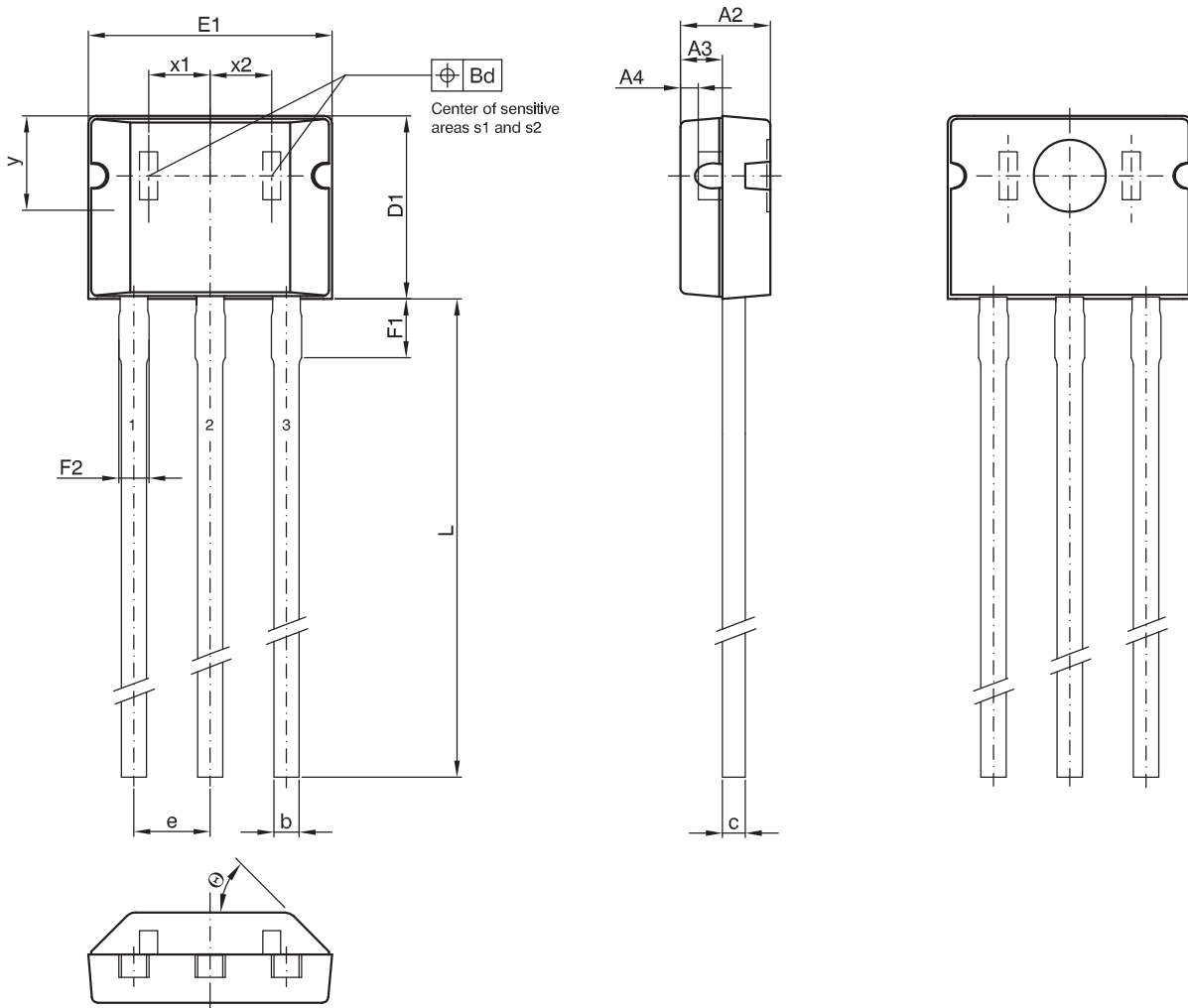
physical dimensions do not include moldflash .

$x1, x2, y$  = these dimensions are different for each sensor type and are specified in the data sheet.

UNIT	A1	A2	A3	A4	b	b1	Bd	c	D	D1	e	E1	L1
mm	0.10 0.02	1.20 1.10	0.73	0.3	0.4	1.7	0.2	0.15	4.0	2.6 2.5	1.5	4.6 4.5	0.25 min.

JEDEC STANDARD		ANSI	ISSUE DATE YY-MM-DD	DRAWING-NO.	ZG-NO.
ISSUE	ITEM NO.				
-	-		07-07-02	06655.0001.4	ZG001055_Ver.02

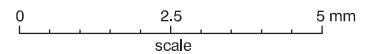
**Fig. 3-1:**  
**SOT89B-2:** Plastic Small Outline Transistor package, 4 leads, with two sensitive areas  
 Weight approximately 0.034 g



physical dimensions do not include moldflash.

solderability is guaranteed between end of pin and distance F1.

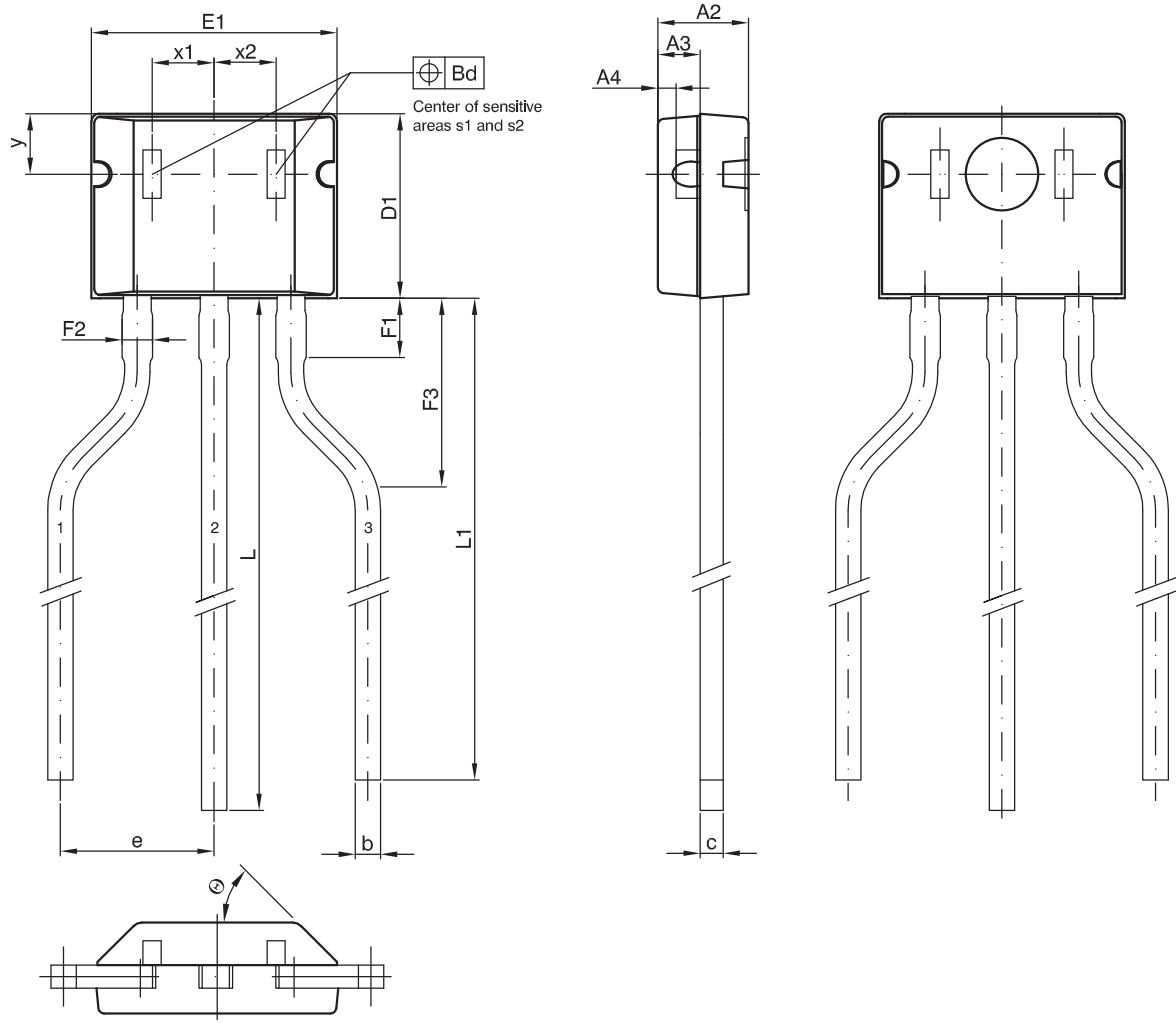
Bd, x1, x2, y = these dimensions are different for each sensor type and are specified in the data sheet.



UNIT	A2	A3	A4	b	c	D1	e	E1	F1	F2	L	Θ
mm	1.55 1.45	0.7	0.3	0.42	0.36	3.1 3.0	1.27	4.11 4.01	1.2 0.8	0.60 0.42	14.5 mlh	45°

JEDEC STANDARD		ANSI	ISSUE DATE YY-MM-DD	DRAWING-NO.	ZG-NO.
ISSUE	ITEM NO.				
-	-		07-07-03	06658.0001.4	ZG001058_Ver.02

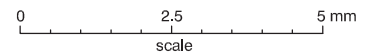
**Fig. 3-2:**  
**TO92UA-4:** Plastic Transistor Standard UA package, 3 leads, not spread, with two sensitive areas  
 Weight approximately 0.106 g



physical dimensions do not include moldflash.

solderability is guaranteed between end of pin and distance F1.

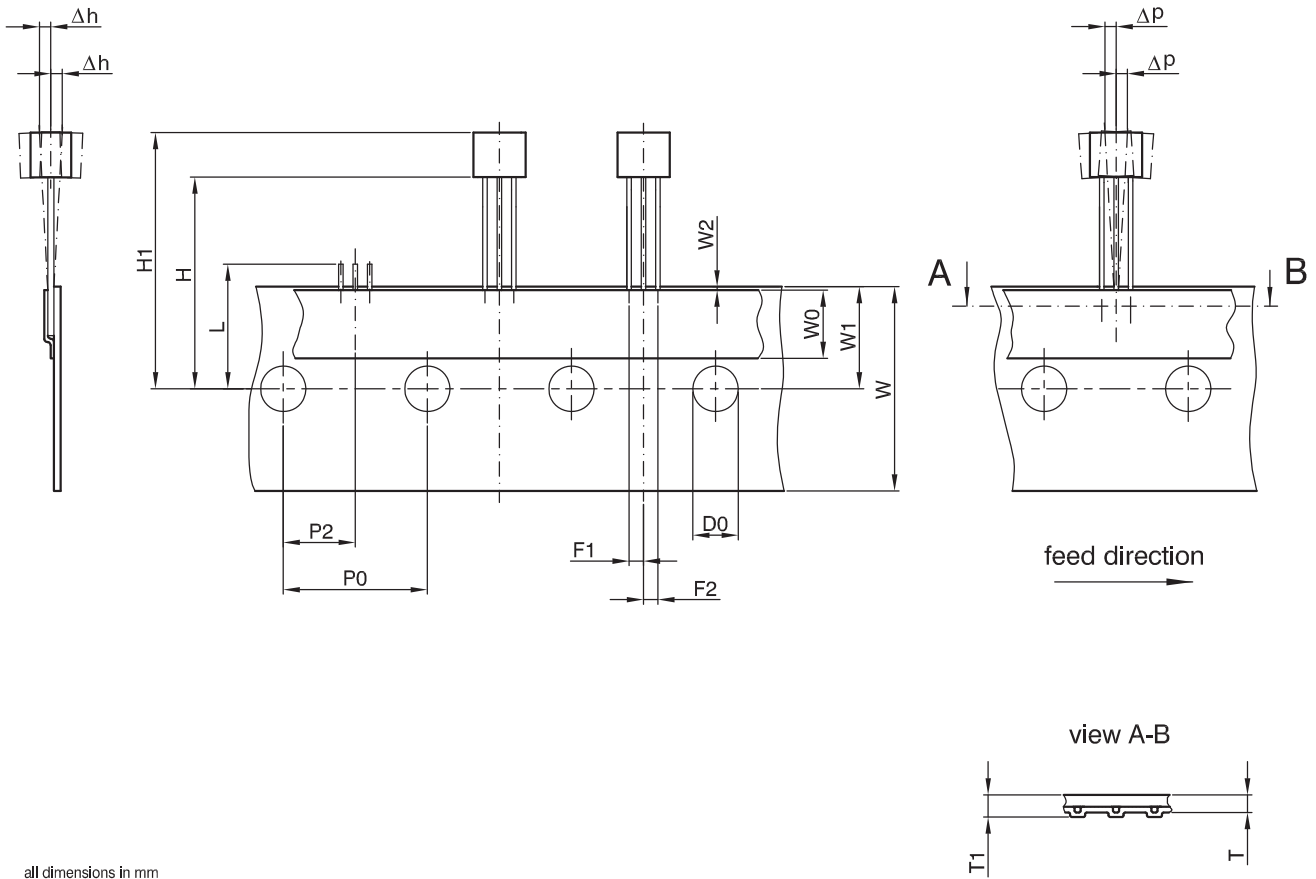
Bd, x1, x2, y = these dimensions are different for each sensor type and are specified in the data sheet.



UNIT	A2	A3	A4	b	c	D1	e	E1	F1	F2	F3	L	L1	θ
mm	1.55 1.45	0.7	0.3	0.42	0.36	3.1 3.0	2.54	4.11 4.01	1.2 0.8	0.60 0.42	4.0 2.0	14.5 min	14.0 min	45°

JEDEC STANDARD		ANSI	ISSUE DATE YY-MM-DD	DRAWING-NO.	ZG-NO.
ISSUE	ITEM NO.				
-	-		07-07-03	06657.0001.4	ZG001057_Ver.02

**Fig. 3-3:**  
**TO92UA-3:** Plastic Transistor Standard UA package, 3 leads, spread, with two sensitive areas  
 Weight approximately 0.106 g

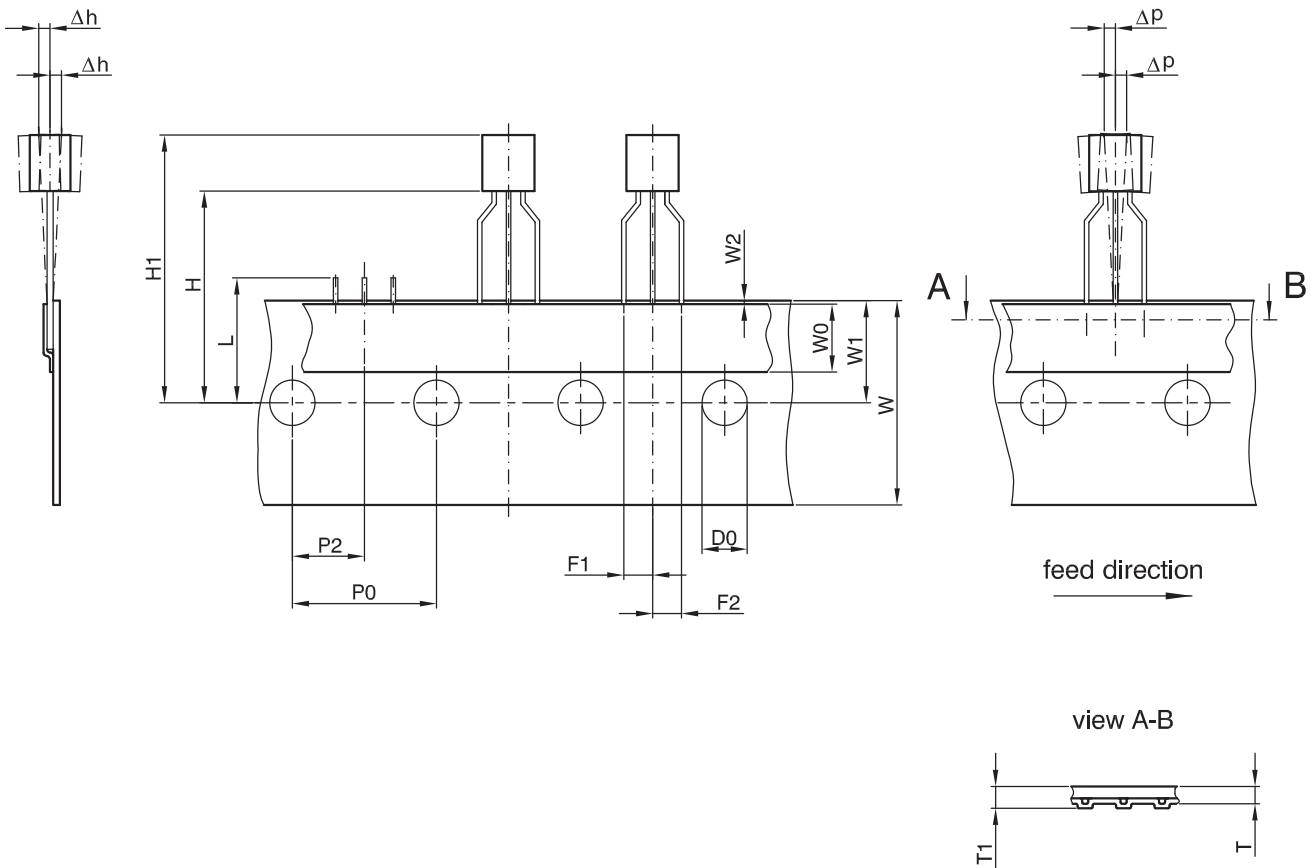


all dimensions in mm  
 other dimensions see drawing of bulk  
 max. allowed tolerance over 20 hole spacings  $\pm 1.0$   
 H1 = this dimension is different for each sensor type and is specified in the data sheet

UNIT	D0	F1	F2	H	$\Delta h$	L	P0	P2	$\Delta p$	T	T1	W	W0	W1	W2
mm	4.0	1.47 1.07	1.47 1.07	20.0 18.0	$\pm 1.0$	11.0 max	13.2 12.2	7.05 5.65	$\pm 1.0$	0.5	0.9	18.0	6.0	9.0	0.3

JEDEC STANDARD		ANSI	ISSUE DATE YY-MM-DD	DRAWING-NO.	ZG-NO.
ISSUE	ITEM NO.				
-	ICE 60286-2		07-01-18	06631.0001.4	ZG001031_Ver.03

**Fig. 3-4:**  
**TO92UA-4:** Dimensions ammpack inline, not spread



all dimensions in mm  
 other dimensions see drawing of bulk  
 max. allowed tolerance over 20 hole spacings  $\pm 1.0$   
 H1 = this dimension is different for each sensor type and is specified in the data sheet

UNIT	D0	F1	F2	H	$\Delta h$	L	P0	P2	$\Delta p$	T	T1	W	W0	W1	W2
mm	4.0	2.74 2.34	2.74 2.34	20.0 18.0	$\pm 1.0$	11.0 max	13.2 12.2	7.05 5.65	$\pm 1.0$	0.5	0.9	18.0	6.0	9.0	0.3

JEDEC STANDARD		ANSI	ISSUE DATE YY-MM-DD	DRAWING-NO.	ZG-NO.
ISSUE	ITEM NO.				
-	ICE 60286-2		07-01-18	06632.0001.4	ZG001032_Ver.04

**Fig. 3-5:**  
**TO92UA-3: Dimensions ammpack inline, spread**

**3.2. Dimensions of Sensitive Area**

0.08 mm x 0.17 mm

**3.3. Positions of Sensitive Areas (nominal values)**

SOT89B-2	TO92UA-3/-4
$x_1 = -1.025$ mm	
$x_2 = 1.025$ mm	
$x_1 - x_2 = 2.05$ mm	
$y = 0.95$ mm	$y = 1.0$ mm
$Bd = 0.2$ mm	

**3.4. Absolute Maximum Ratings**

Stresses beyond those listed in the “Absolute Maximum Ratings” may cause permanent damage to the device. This is a stress rating only. Functional operation of the device at these conditions is not implied. Exposure to absolute maximum rating conditions for extended periods will affect device reliability.

This device contains circuitry to protect the inputs and outputs against damage due to high static voltages or electric fields; however, it is advised that normal precautions be taken to avoid application of any voltage higher than absolute maximum-rated voltages to this high-impedance circuit.

All voltages listed are referenced to ground (GND).

Symbol	Parameter	Pin No.	Limit Values		Unit
			Min.	Max.	
$V_{DD}$	Supply Voltage	1	-15	28 <sup>1)</sup>	V
$V_O$	Output Voltage	3	-0.3	28 <sup>1)</sup>	V
$I_O$	Continuous Output On Current	3	-	30	mA
$T_J$	Junction Temperature Range		-40 -40	150 170 <sup>2)</sup>	°C
<sup>1)</sup> as long as $T_{Jmax}$ is not exceeded <sup>2)</sup> $t < 1000h$					

**3.4.1. Storage and Shelf Life**

The permissible storage time (shelf life) of the sensors is unlimited, provided the sensors are stored at a maximum of 30 °C and a maximum of 85% relative humidity. At these conditions, no Dry Pack is required.

Solderability is guaranteed for one year from the date code on the package.

### 3.5. Recommended Operating Conditions

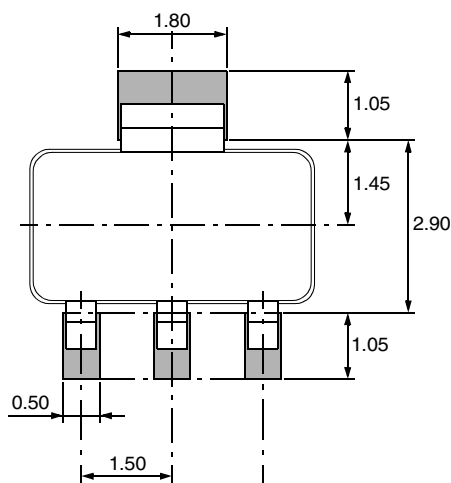
Functional operation of the device beyond those indicated in the “Recommended Operating Conditions” of this specification is not implied, may result in unpredictable behavior of the device and may reduce reliability and lifetime.

All voltages listed are referenced to ground (GND).

Symbol	Parameter	Pin No.	Limit Values		Unit
			Min.	Max.	
$V_{DD}$	Supply Voltage	1	4.5	24	V
$I_O$	Continuous Output On Current	3	–	20	mA
$V_O$	Output Voltage	3	–	24	V

**3.6. Characteristics** at  $T_J = -40\text{ }^\circ\text{C}$  to  $+170\text{ }^\circ\text{C}$ ,  $V_{DD} = 4.5\text{ V}$  to  $24\text{ V}$ ,  $GND = 0\text{ V}$   
 at Recommended Operation Conditions if not otherwise specified in the column “Conditions”.  
 Typical Characteristics for  $T_J = 25\text{ }^\circ\text{C}$  and  $V_{DD} = 12\text{ V}$

Symbol	Parameter	Pin No.	Limit Values			Unit	Conditions
			Min.	Typ.	Max.		
$I_{DD}$	Supply Current	1	4.0	5.5	6.8	mA	$T_J = 25\text{ }^\circ\text{C}$
$I_{DD}$	Supply Current over Temperature Range	1	2.5	5	7.5	mA	
$V_{DDZ}$	Overvoltage Protection at Supply	1	–	28.5	32.5	V	$I_{DD} = 25\text{ mA}$ , $T_J = 25\text{ }^\circ\text{C}$ , $t = 20\text{ ms}$
$V_{OZ}$	Overvoltage Protection at Output	3	–	28	32.5	V	$I_{OL} = 25\text{ mA}$ , $T_J = 25\text{ }^\circ\text{C}$ , $t = 20\text{ ms}$
$V_{OL}$	Output Voltage over Temperature Range	3	–	180	400	mV	$I_O = 20\text{ mA}$
$I_{OH}$	Output Leakage Current over Temperature Range	3	–	0.06	10	$\mu\text{A}$	$V_{OH} = 4.5\text{ V} \dots 24\text{ V}$ , $\Delta B < \Delta B_{OFF}$ , $T_J \leq 150\text{ }^\circ\text{C}$
$f_{osc}$	Internal Oscillator Chopper Frequency	–	–	62	–	kHz	
$t_{en(O)}$	Enable Time of Output after Setting of $V_{DD}$	3	–	35	–	$\mu\text{s}$	$V_{DD} = 12\text{ V}$ , $\Delta B > \Delta B_{ON} + 2\text{mT}$ or $\Delta B < \Delta B_{OFF} - 2\text{mT}$
$t_r$	Output Rise Time	3	–	80	400	ns	$V_{DD} = 12\text{ V}$ , $R_L = 820\ \Omega$ , $C_L = 20\text{ pF}$
$t_f$	Output Fall Time	3	–	45	400	ns	$V_{DD} = 12\text{ V}$ , $R_L = 820\ \Omega$ , $C_L = 20\text{ pF}$
$R_{thJSB}$ case SOT89B-2	Thermal Resistance Junction to Substrate Backside		–	150	200	K/W	Fiberglass Substrate 30 mm x 10 mm x 1.5 mm, pad size see Fig. 3–6
$R_{thJS}$ case TO92UA-3, TO92UA-4	Thermal Resistance Junction to Soldering Point		–	150	200	K/W	



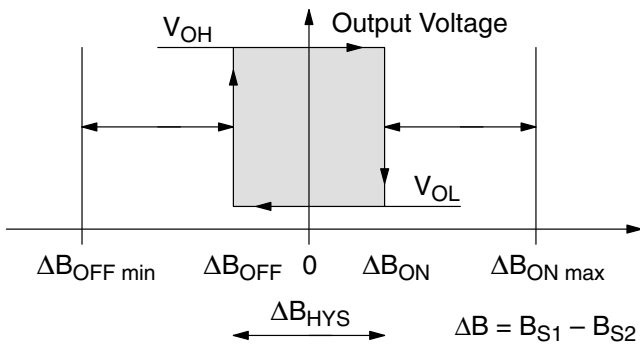
**Fig. 3–6:**  
 Recommended footprint SOT89B, Dimensions in mm  
 All dimensions are for reference only. The pad size may vary depending on the requirements of the soldering process.

**3.7. Magnetic Characteristics** at  $T_J = -40\text{ }^\circ\text{C}$  to  $+170\text{ }^\circ\text{C}$ ,  $V_{DD} = 4.5\text{ V}$  to  $24\text{ V}$   
 Typical Characteristics for  $V_{DD} = 12\text{ V}$

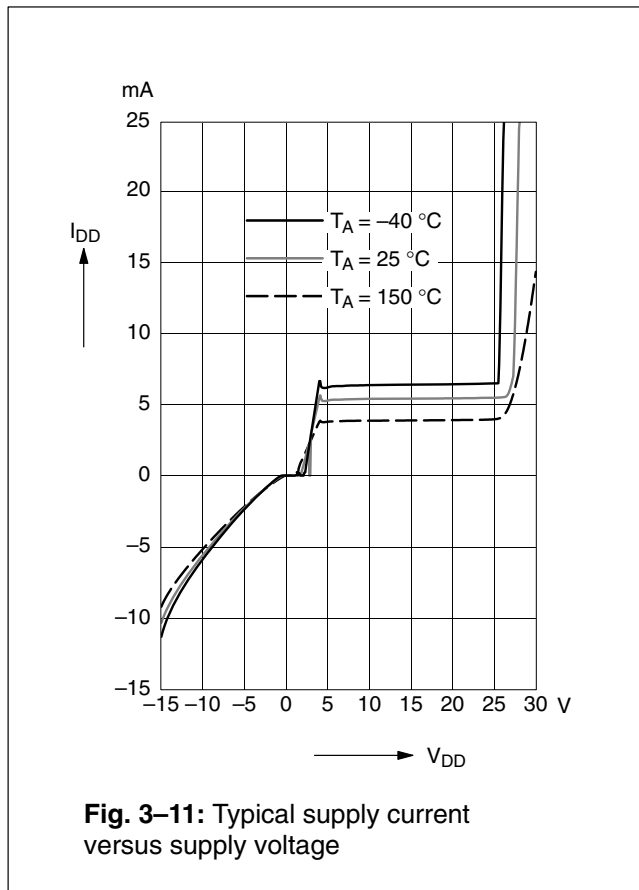
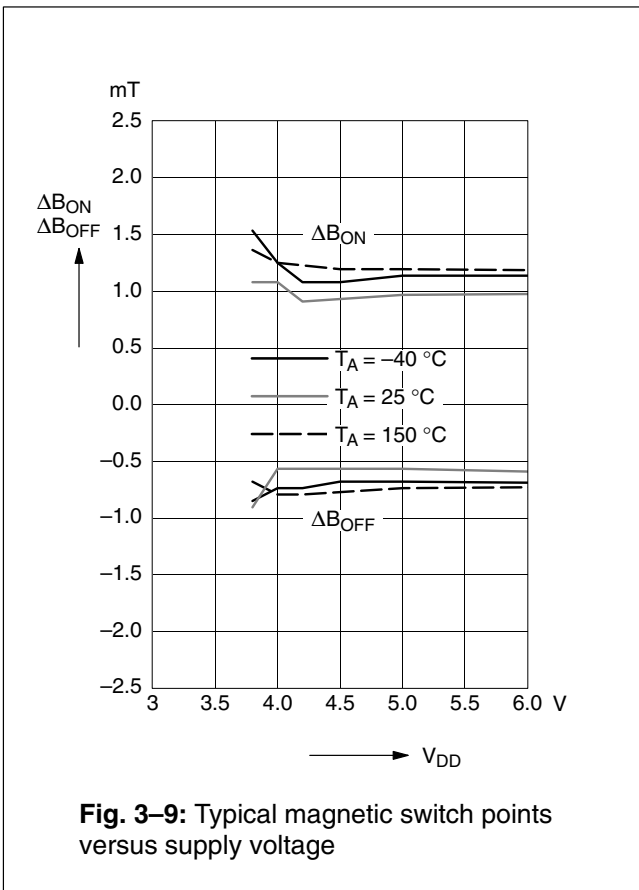
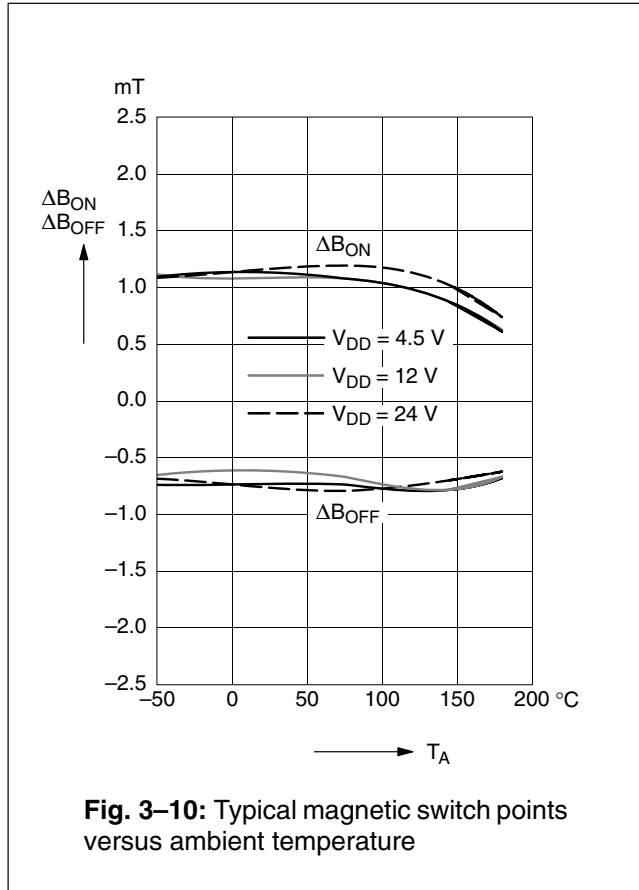
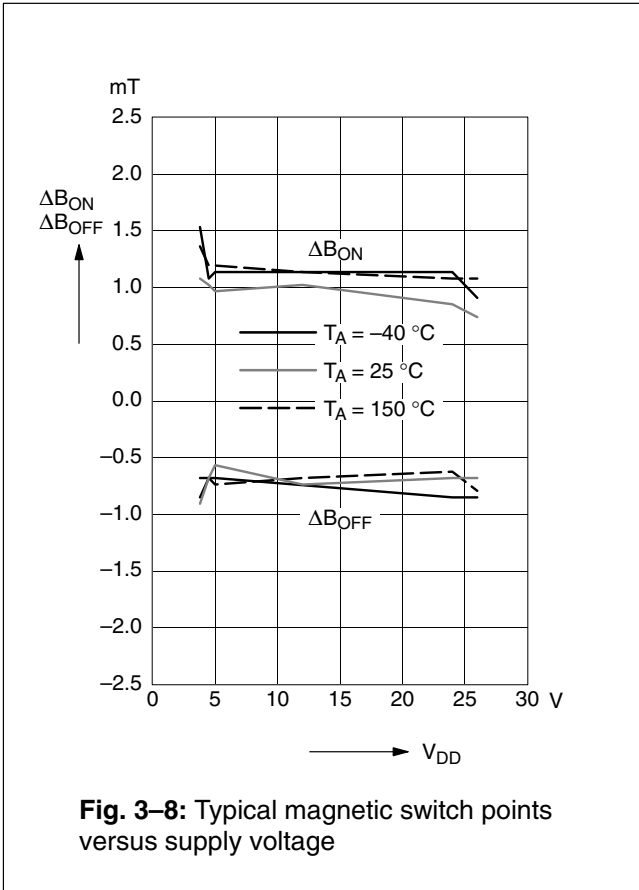
Magnetic flux density values of switching points (Condition:  $-10\text{ mT} < B_0 < 10\text{ mT}$ )

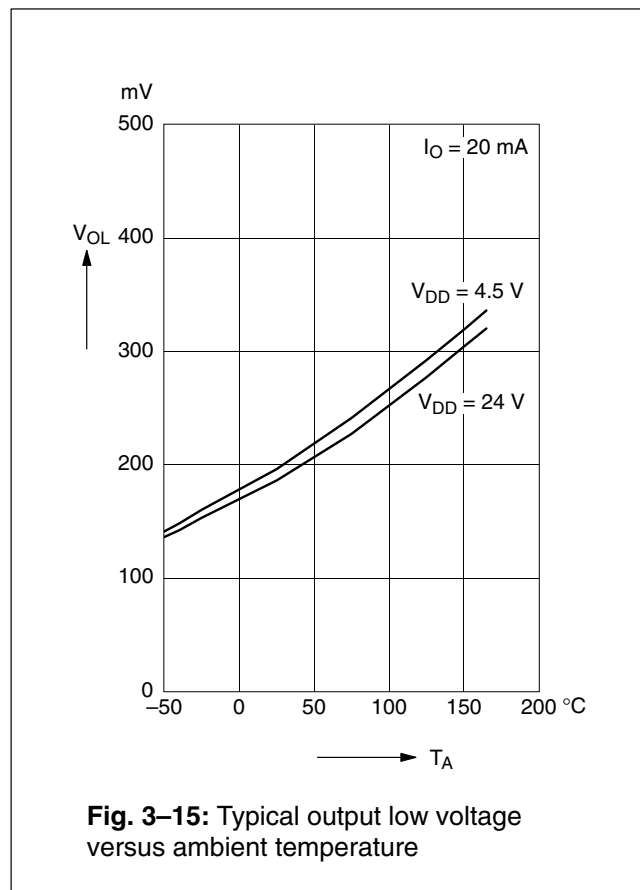
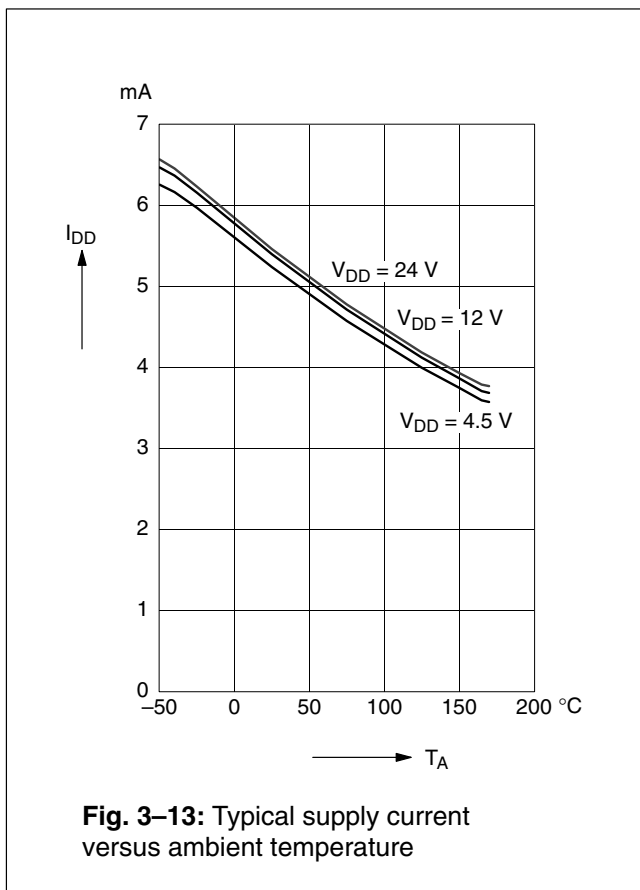
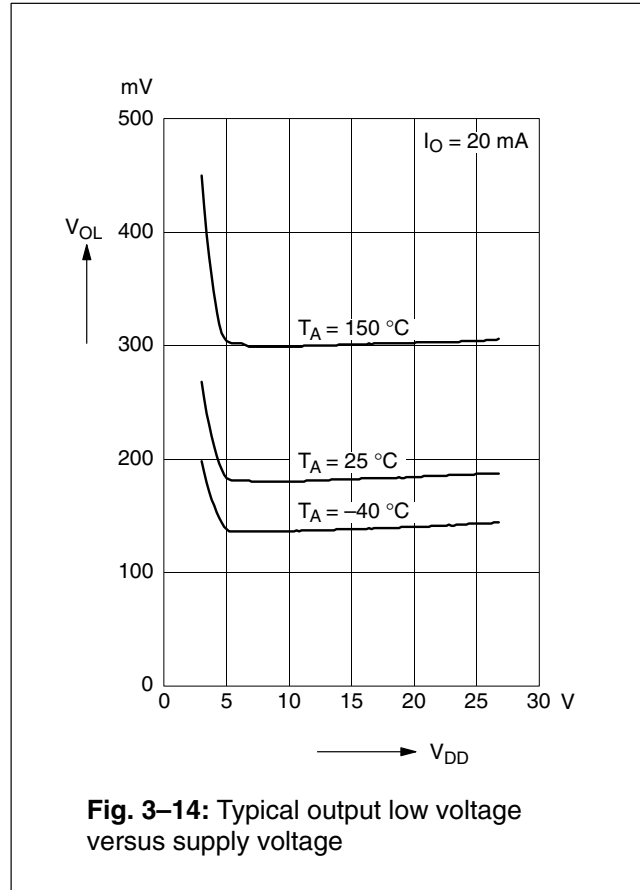
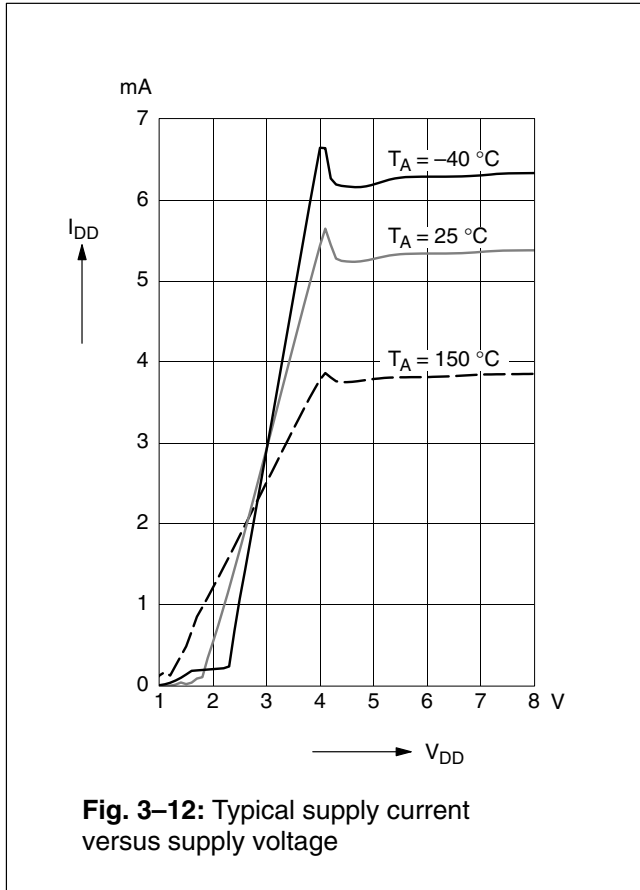
Positive flux density values refer to the magnetic south pole at the branded side of the package.  $\Delta B = B_{S1} - B_{S2}$

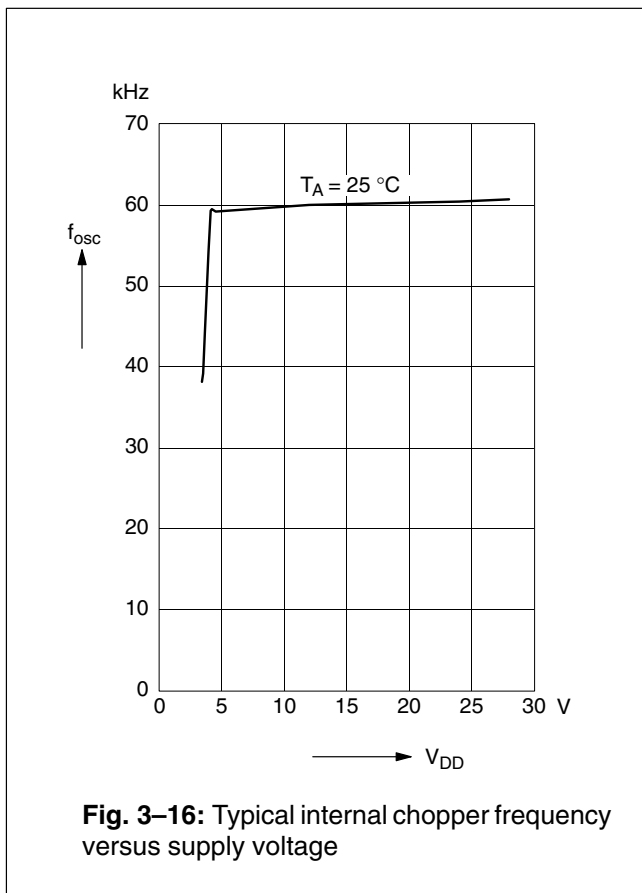
Parameter	-40 °C			25 °C			140 °C			170 °C			Unit
	Min.	Typ.	Max.	Min.	Typ.	Max.	Min.	Typ.	Max.	Min.	Typ.	Max.	
On point $\Delta B_{ON}$ $\Delta B > \Delta B_{ON}$	0.2	1.2	2.2	0	1.2	2.2	-1.8	0.6	2.8	-2.0	0.5	3.0	mT
Off point $\Delta B_{OFF}$ $\Delta B < \Delta B_{OFF}$	-2.2	-1.0	-0.2	-2.2	-1.0	0	-2.8	-1.2	1.8	-3.0	-1.2	2.0	mT
Hysteresis $\Delta B_{HYS} = \Delta B_{ON} - \Delta B_{OFF}$	1.2	2.2	3.0	1.2	2.2	3.0	0.9	1.8	3.0	0.8	1.7	3.0	mT
Offset $\Delta B_{OFFSET} = (\Delta B_{ON} + \Delta B_{OFF})/2$	-1.1	0.1	1.1	-1.1	0.1	1.1	-2.2	-0.3	2.2	-2.5	-0.5	2.5	mT



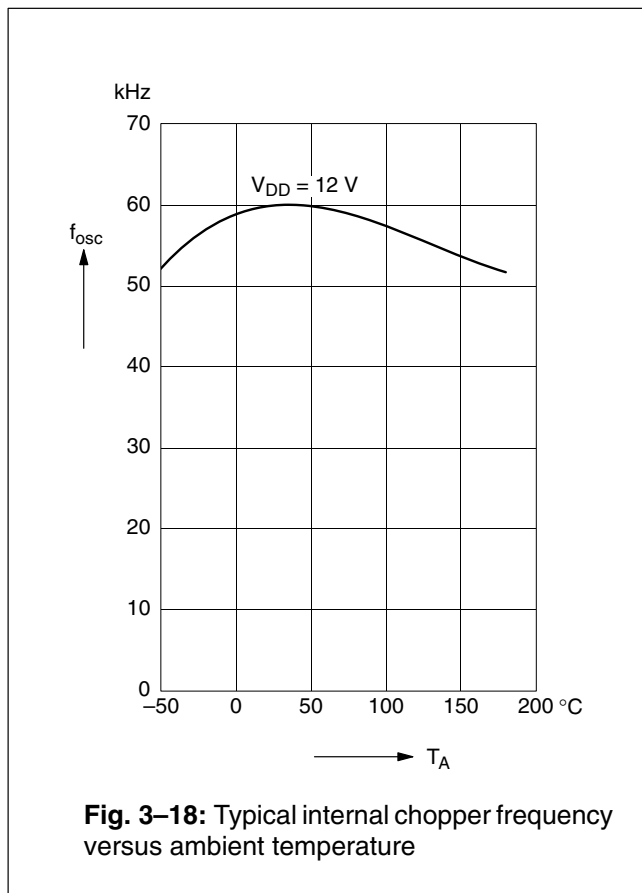
**Fig. 3-7:** Definition of switching points and hysteresis



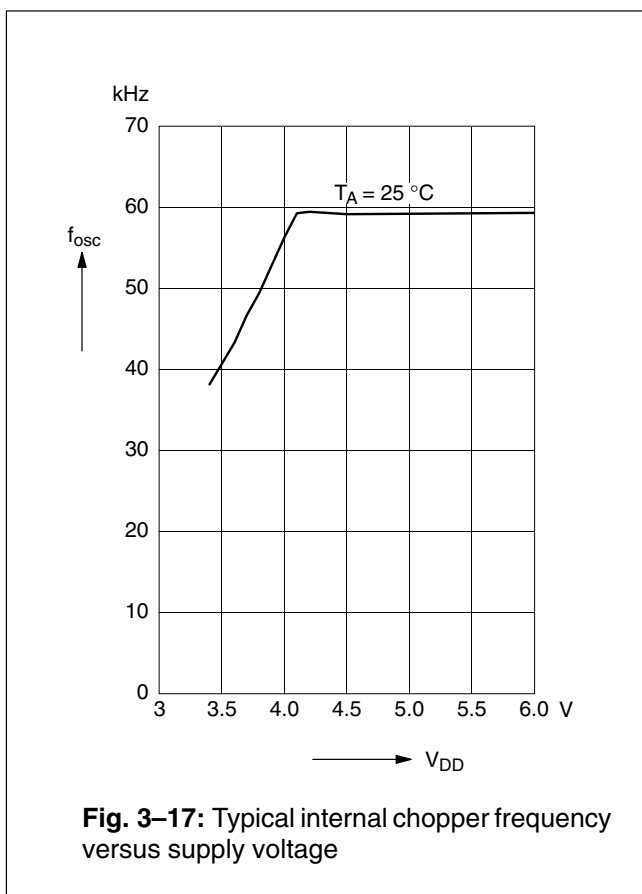




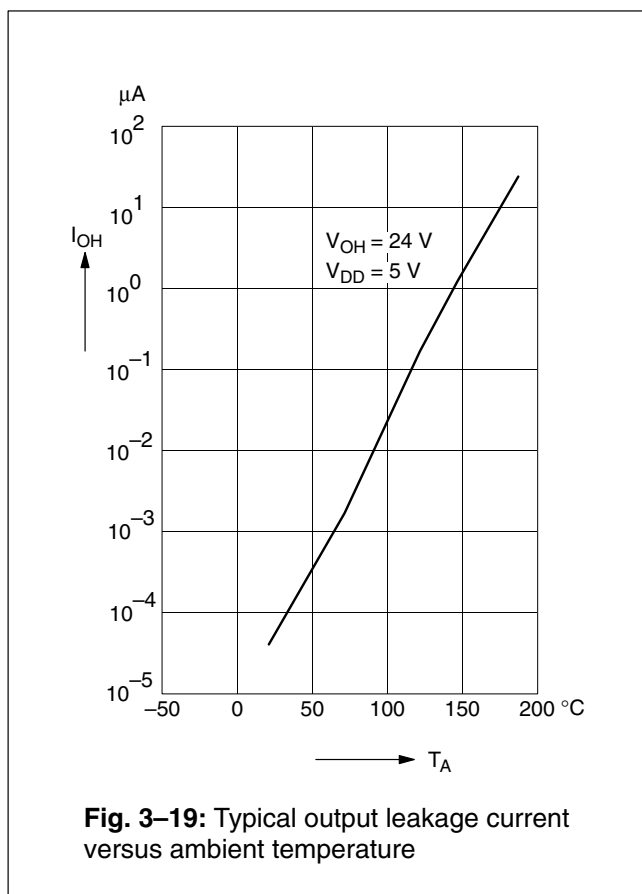
**Fig. 3–16:** Typical internal chopper frequency versus supply voltage



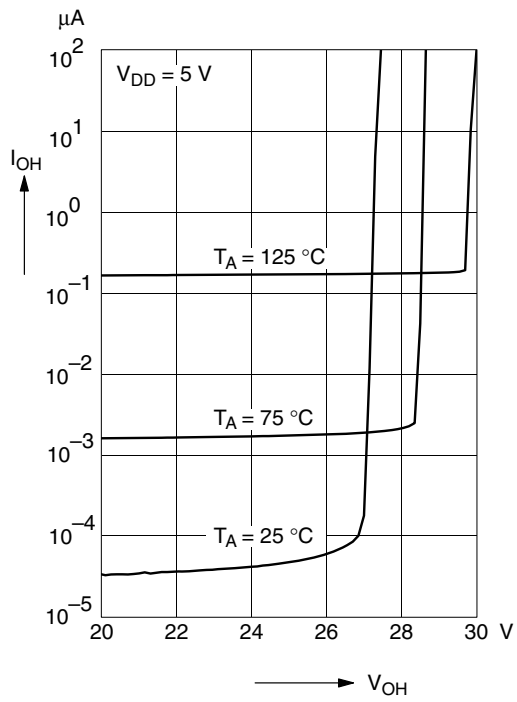
**Fig. 3–18:** Typical internal chopper frequency versus ambient temperature



**Fig. 3–17:** Typical internal chopper frequency versus supply voltage



**Fig. 3–19:** Typical output leakage current versus ambient temperature



**Fig. 3-20:** Typical output leakage current versus output voltage

**4. Application Notes**

Mechanical stress can change the sensitivity of the Hall plates and an offset of the magnetic switching points may result. External mechanical stress to the package can influence the magnetic parameters if the sensor is used under back-biased applications. This piezo sensitivity of the sensor IC cannot be completely compensated for by the switching offset compensation technique.

For back-biased applications, the HAL320 is recommended. In such cases, please contact our Application Department. They will provide assistance in avoiding applications which may induce stress to the ICs. This stress may cause drifts of the magnetic parameters indicated in this data sheet.

**4.1. Ambient Temperature**

Due to the internal power dissipation, the temperature on the silicon chip (junction temperature  $T_J$ ) is higher than the temperature outside the package (ambient temperature  $T_A$ ).

$$T_J = T_A + \Delta T$$

Under static conditions and continuous operation, the following equation applies:

$$\Delta T = I_{DD} * V_{DD} * R_{th}$$

For typical values, use the typical parameters. For worst case calculation, use the max. parameters for  $I_{DD}$  and  $R_{th}$ , and the max. value for  $V_{DD}$  from the application.

For all sensors, the junction temperature range  $T_J$  is specified. The maximum ambient temperature  $T_{Amax}$  can be calculated as:

$$T_{Amax} = T_{Jmax} - \Delta T$$

**4.2. Extended Operating Conditions**

All sensors fulfill the electrical and magnetic characteristics when operated within the Recommended Operating Conditions (see page 13).

**Supply Voltage Below 4.5 V**

Typically, the sensors operate with supply voltages above 3 V, however, below 4.5 V some characteristics may be outside the specification.

---

**Note:** The functionality of the sensor below 4.5 V is not tested on a regular base. For special test conditions, please contact Micronas.

---

**4.3. Start-up Behavior**

Due to the active offset compensation, the sensors have an initialization time (enable time  $t_{en(O)}$ ) after applying the supply voltage. The parameter  $t_{en(O)}$  is specified in the Electrical Characteristics (see page 14).

During the initialization time, the output state is not defined and the output can toggle. After  $t_{en(O)}$ , the output will be low if the applied magnetic field  $B$  is above  $B_{ON}$ . The output will be high if  $B$  is below  $B_{OFF}$ .

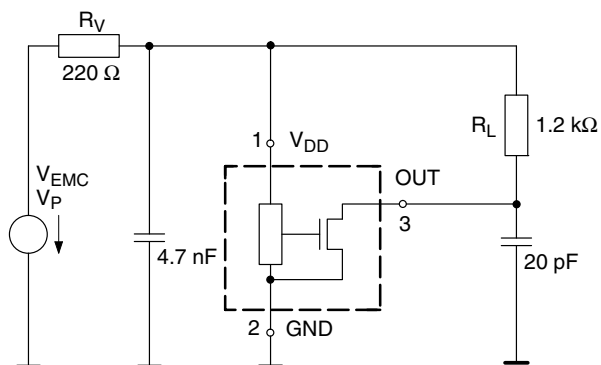
For magnetic fields between  $B_{OFF}$  and  $B_{ON}$ , the output state of the HAL sensor after applying  $V_{DD}$  will be either low or high. In order to achieve a well-defined output state, the applied magnetic field must be above  $B_{ONmax}$ , respectively, below  $B_{OFFmin}$ .

#### 4.4. EMC and ESD

For applications with disturbances on the supply line or radiated disturbances, a series resistor and a capacitor are recommended (see Fig. 4–1). The series resistor and the capacitor should be placed as closely as possible to the HAL sensor.

Applications with this arrangement passed the EMC tests according to the product standard ISO 7637.

Please contact Micronas for the detailed investigation reports with the EMC and ESD results.



**Fig. 4–1:** Test circuit for EMC investigations

## 5. Data Sheet History

1. Final data sheet: "HAL300 Differential Hall Effect Sensor IC", July 15, 1998, 6251-345-1DS. First release of the final data sheet.
2. Final data sheet: "HAL300 Differential Hall Effect Sensor IC", April 23, 2004, 6251-345-2DS. Second release of the final data sheet. Major changes:
  - temperature range "C" removed
  - additional temperature range "K"
  - new package diagrams for SOT89-2 and TO92UA-4
  - package diagram for TO92UA-3 added
  - ammopack diagrams for TO92UA-3/-4 added
3. Final data sheet: "HAL300 Differential Hall Effect Sensor IC", Feb. 2, 2005, 6251-345-3DS. Third release of the final data sheet. Major changes:
  - Section 3.3.: dimension Bd added to table
  - Fig. 3–6: Recommended footprint SOT89 changed
4. Final data sheet: "HAL300 Differential Hall Effect Sensor IC", Nov. 24, 2008, DSH000016\_002. Fourth release of the final data sheet. Major changes:
  - Section 1.5. "Solderability and Welding" updated
  - package diagrams updated