

Data Sheet

HAL[®] 2xy

Hall-Effect Sensor Family

Copyright, Warranty, and Limitation of Liability

The information and data contained in this document are believed to be accurate and reliable. The software and proprietary information contained therein may be protected by copyright, patent, trademark and/or other intellectual property rights of Micronas. All rights not expressly granted remain reserved by Micronas.

Micronas assumes no liability for errors and gives no warranty representation or guarantee regarding the suitability of its products for any particular purpose due to these specifications.

By this publication, Micronas does not assume responsibility for patent infringements or other rights of third parties which may result from its use. Commercial conditions, product availability and delivery are exclusively subject to the respective order confirmation.

Any information and data which may be provided in the document can and do vary in different applications, and actual performance may vary over time.

All operating parameters must be validated for each customer application by customers' technical experts. Any new issue of this document invalidates previous issues. Micronas reserves the right to review this document and to make changes to the document's content at any time without obligation to notify any person or entity of such revision or changes. For further advice please contact us directly.

Do not use our products in life-supporting systems, aviation and aerospace applications! Unless explicitly agreed to otherwise in writing between the parties, Micronas' products are not designed, intended or authorized for use as components in systems intended for surgical implants into the body, or other applications intended to support or sustain life, or for any other application in which the failure of the product could create a situation where personal injury or death could occur.

No part of this publication may be reproduced, photocopied, stored on a retrieval system or transmitted without the express written consent of Micronas.

Micronas Trademarks

– HAL

Third-Party Trademarks

All other brand and product names or company names may be trademarks of their respective companies.

Contents

Page	Section	Title
4	1.	Introduction
4	1.1.	Family Overview
4	1.2.	Features
5	1.3.	Marking Code
5	1.4.	Operating Junction Temperature Range
5	1.5.	Solderability and Welding
6	2.	Functional Description
7	3.	Specifications
7	3.1.	Outline Dimensions
10	3.2.	Dimensions of Sensitive Area
10	3.3.	Positions of Sensitive Areas
10	3.4.	Absolute Maximum Ratings
10	3.4.1.	Storage and Shelf Life
11	3.5.	Recommended Operating Conditions
11	3.6.	Characteristics
13	3.7.	Magnetic Characteristics Overview
15	4.	Application Notes
15	4.1.	Ambient Temperature
15	4.2.	HAL20y, HAL21y Operation
15	4.2.1.	Extended Operating Conditions
15	4.2.2.	Start-up Behavior
15	4.3.	HAL22y Operation
15	4.3.1.	Extended Operating Conditions
15	4.3.2.	Start-up Behavior
16	4.4.	EMC and ESD
17	5.	Data Sheet History

Hall-Effect Sensor Family

Release Note: Revision bars indicate significant changes to the previous edition.

1. Introduction

The HAL 2xy Hall switch family is produced in CMOS technology. The sensors include a temperature-compensated Hall plate with active offset compensation, a comparator, and an open-drain output transistor. The comparator compares the actual magnetic flux through the Hall plate (Hall voltage) with the fixed reference values (switching points). Accordingly, the output transistor is switched on or off. In addition the HAL22y sensors features a power-on and undervoltage reset.

The active offset compensation leads to magnetic parameters which are robust against mechanical stress effects. In addition, the magnetic characteristics are constant in the full supply voltage and temperature range.

The sensors are designed for industrial and automotive applications and operate with supply voltages from 3.8 V to 24 V in the ambient temperature range from -40 °C up to 125 °C. For HAL22y the minimum supply voltage is 4.3 V.

The HAL 2xy family is available in the SMD package SOT89B-3 and in the leaded versions TO92UA-5 and TO92UA-6.

1.1. Family Overview

This sensor family consists of sensors with latching and unipolar output behavior.

Type	Switching Behavior	Sensitivity	see Page
201	unipolar	low	13
203	latching	medium	13
204	latching	low	13
206	unipolar	high	13
207	unipolar	low	13
208	unipolar	medium	13
210	unipolar	high	13

Type	Switching Behavior	Sensitivity	see Page
211	unipolar with inverted output (north polarity)	high	13
212	unipolar	low	13

Family members with power-on and undervoltage reset (HAL22y):

Type	Switching Behavior	Sensitivity	see Page
220	latching	high	13
221	unipolar	low	13

1.2. Features

- switching offset compensation
- operates from 3.8 V to 24 V supply voltage (HAL22y minimum supply voltage is 4.3 V)
- power-on and undervoltage reset in case of HAL22y
- operates with static magnetic fields and dynamic magnetic fields up to 10 kHz
- overvoltage protection at all pins
- reverse-voltage protection at V_{DD}-pin
- magnetic characteristics are robust against mechanical stress effects
- short-circuit protected open-drain output by thermal shut down
- constant switching points over a wide supply voltage and temperature range
- the decrease of magnetic flux density caused by rising temperature in the sensor system is compensated by a built-in negative temperature coefficient of the magnetic characteristics
- superior temperature stability for automotive or industrial applications
- high ESD rating
- EMC corresponding to ISO 7637

Unipolar Sensors:

The output turns low with the magnetic south pole on the branded side of the package and turns high if the magnetic field is removed. The sensor does not respond to the magnetic north pole on the branded side.

Latching Sensors:

The sensors have a latching behavior and require a magnetic north and south pole for correct functioning. The output turns low with the magnetic south pole on the branded side of the package and turns high with the magnetic north pole on the branded side. The output does not change if the magnetic field is removed. For changing the output state, the opposite magnetic field polarity must be applied.

Unipolar Switching Sensors with Inverted Output Sensitive to North Pole:

The output turns high with the magnetic north pole on the branded side of the package and turns low if the magnetic field is removed. The sensor does not respond to the magnetic south pole on the branded-side.

1.3. Marking Code

All Hall sensors have a marking on the package surface (branded side). This marking includes the name of the sensor and the temperature range.

Type	Temperature Range K
HAL201	201K
HAL203	203K
HAL204	204K
HAL206	206K
HAL207	207K
HAL208	208K
HAL210	210K
HAL211	211K
HAL212	212K
HAL220	220K
HAL221	221K

1.4. Operating Junction Temperature Range

The Hall sensors from Micronas are specified to the chip temperature (junction temperature T_J).

K: $T_J = -40\text{ °C to }+140\text{ °C}$

Note: Due to power dissipation, there is a difference between the ambient temperature (T_A) and junction temperature. Please refer to section 4.1. on page 15 for details.

Hall Sensor Package Codes

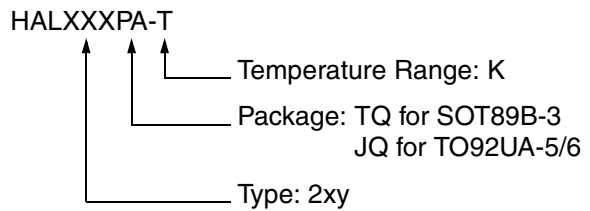

Example: **HAL203JQ-K**

- Type: 203
- Package: TO92UA-6
- Temperature Range: $T_J = -40\text{ °C to }+140\text{ °C}$

Hall sensors are available in a wide variety of packaging versions and quantities. For more detailed information, please refer to the brochure: “Hall Sensors. Ordering Codes, Packaging, Handling”.

1.5. Solderability and Welding

During soldering reflow processing and manual reworking, a component body temperature of 260 °C should not be exceeded.

Device terminals shall be compatible with laser and electrical welding. Please, note that the success of the welding process is subject to different welding parameters which will vary according to the welding technique used. A very close control of the welding parameters is absolutely necessary in order to reach satisfying results. Micronas, therefore, does not give any implied or express warranty as to the ability to weld the component.

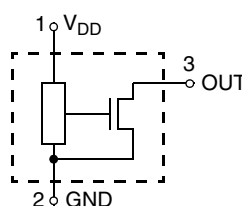

Fig. 1-1: Pin configuration

2. Functional Description

The Hall effect sensor is a monolithic integrated circuit that switches in response to magnetic fields. If a magnetic field with flux lines perpendicular to the sensitive area is applied to the sensor, the biased Hall plate forces a Hall voltage proportional to this field. The Hall voltage is compared with the actual threshold level in the comparator. The temperature-dependent bias increases the supply voltage of the Hall plates and adjusts the switching points to the decreasing induction of magnets at higher temperatures. If the magnetic field exceeds the threshold levels, the open drain output switches to the appropriate state. The built-in hysteresis eliminates oscillation and provides switching behavior of output without bouncing.

Magnetic offset caused by mechanical stress is compensated for by using the “switching offset compensation technique”. Therefore, an internal oscillator provides a two phase clock. The Hall voltage is sampled at the end of the first phase. At the end of the second phase, both sampled and actual Hall voltages are averaged and compared with the actual switching point. Subsequently, the open drain output switches to the appropriate state. The time from crossing the magnetic switching level to switching of output can vary between zero and $1/f_{OSC}$.

Shunt protection devices clamp voltage peaks at the Output pin and V_{DD} -pin together with external series resistors. Reverse current is limited at the V_{DD} -pin by an internal series resistor up to -15 V . No external reverse protection diode is needed at the V_{DD} -pin for reverse voltages ranging from 0 V to -15 V .

In case of HAL22y a built-in reset-circuit clamps the output to the “high” state (reset state) during power-on or when the supply voltage drops below the reset voltage of $V_{reset} < 4.3\text{ V}$. For supply voltages between V_{reset} and 4.3 V , the output state of the device responds to the magnetic field. For supply voltages above 4.3 V , the device works according to the specified characteristics.

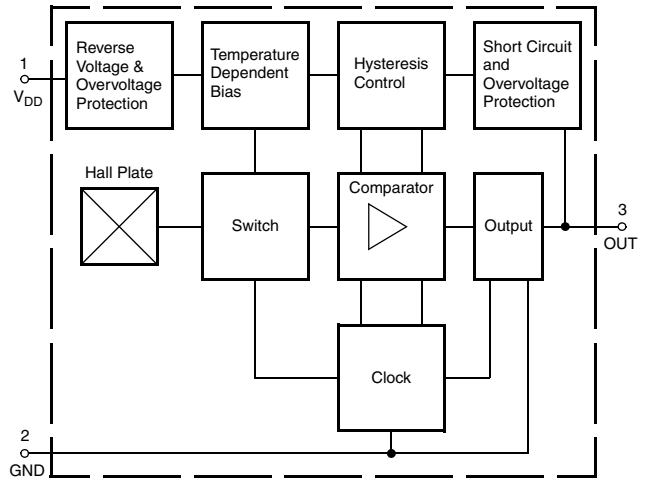

Fig. 2-1: HAL20y and HAL21y block diagram

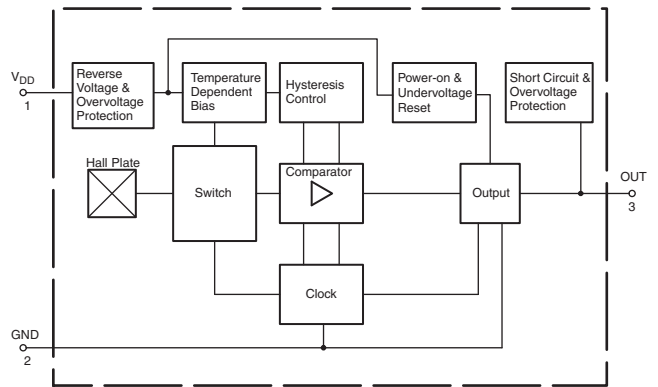

Fig. 2-2: HAL22y block diagram

3. Specifications

3.1. Outline Dimensions

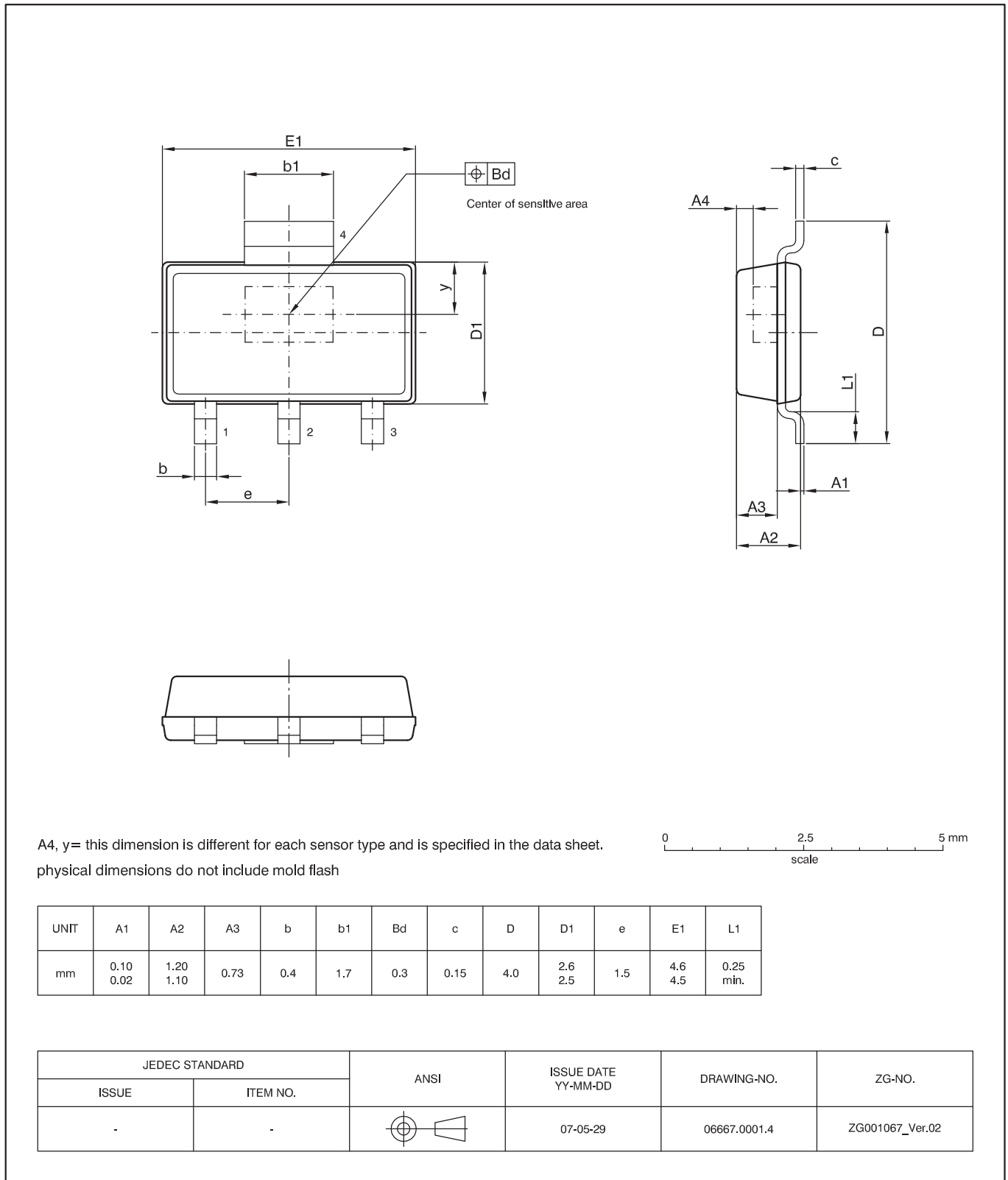

Fig. 3-1:
SOT89B-3: Plastic **S**mall **O**utline **T**ransistor package, 4 leads, with one sensitive area
Weight approximately 0.034 g.

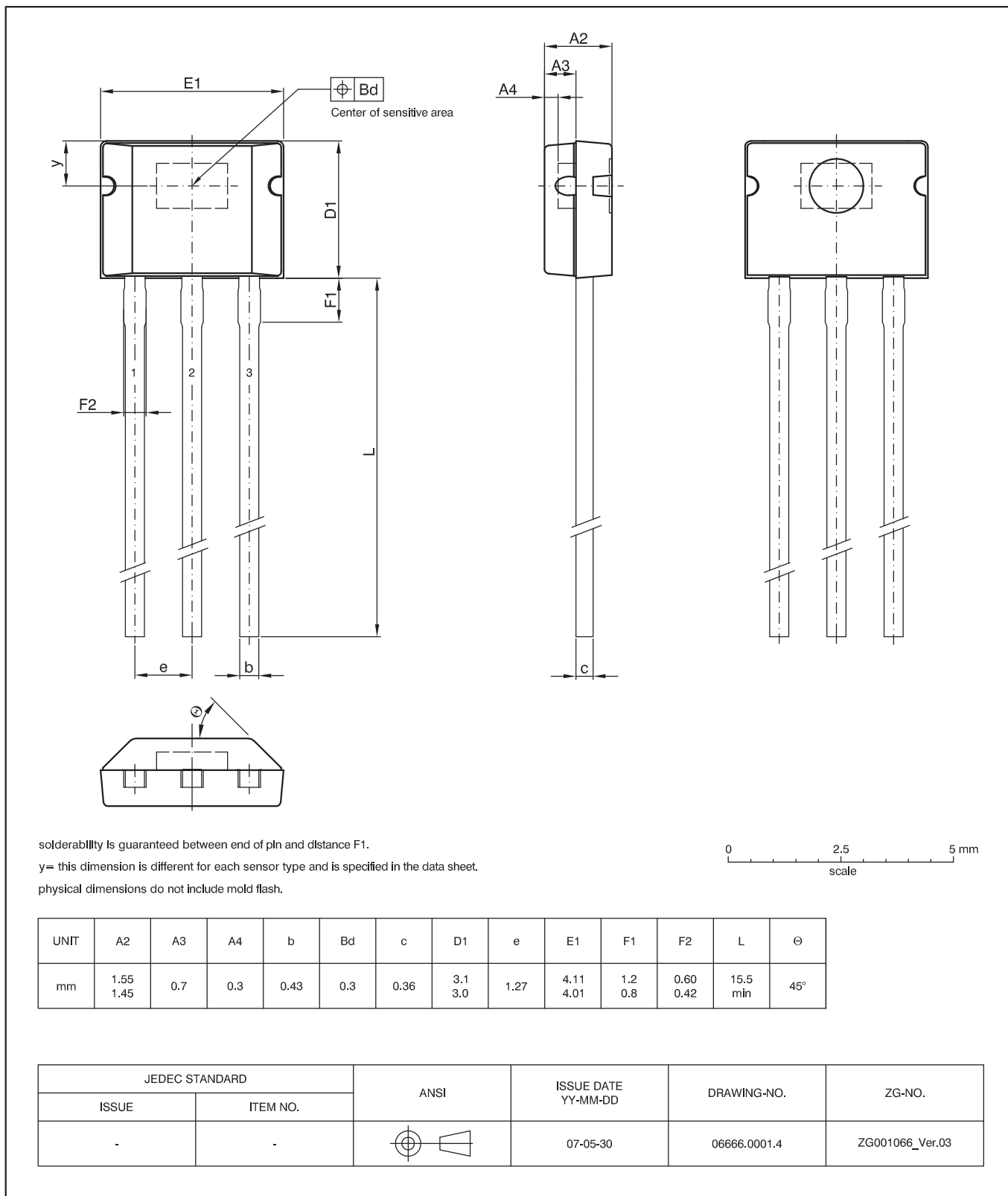
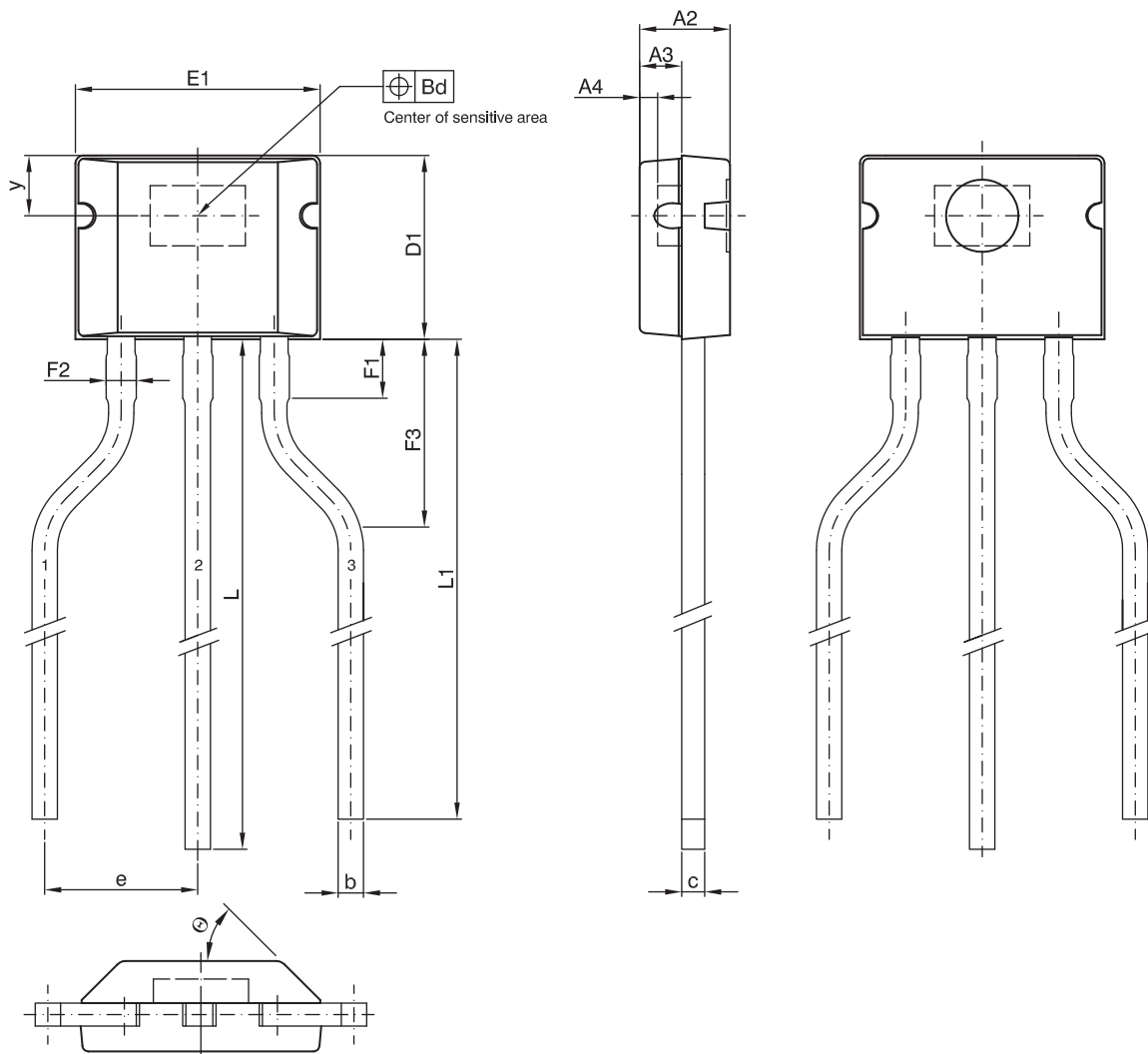
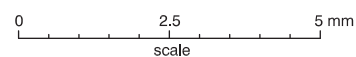

Fig. 3-2:
TO92UA-6: Plastic Transistor Standard UA package, 3 leads
 Weight approximately 0.106 g



solderability is guaranteed between end of pin and distance F1.
 y= this dimension is different for each sensor type and is specified in the data sheet.
 physical dimensions do not include mold flash.



UNIT	A2	A3	A4	b	Bd	c	D1	e	E1	F1	F2	F3	L	L1	⊙
mm	1.55 1.45	0.7	0.3	0.43	0.3	0.36	3.1 3.0	2.54	4.11 4.01	1.0	0.51	4.0 2.0	15.5 min	15.0 min	45°

JEDEC STANDARD		ANSI	ISSUE DATE YY-MM-DD	DRAWING-NO.	ZG-NO.
ISSUE	ITEM NO.				
-	-		09-06-15	06668.0001.4	ZG001068_Ver.03

© Copyright 2009 Micronas GmbH, all rights reserved

Fig. 3-3:
TO92UA-5 Plastic Transistor Standard UA package, 3 leads, spread
 Weight approximately 0.105 g

3.2. Dimensions of Sensitive Area

0.25 mm × 0.12 mm (on chip)

3.3. Positions of Sensitive Areas

	SOT89B-3	TO92UA-5/6
y	0.95 mm nominal	1.08 mm nominal
A4	0.33 mm nominal	0.30 mm nominal

3.4. Absolute Maximum Ratings

Stresses beyond those listed in the “Absolute Maximum Ratings” may cause permanent damage to the device. This is a stress rating only. Functional operation of the device at these conditions is not implied. Exposure to absolute maximum rating conditions for extended periods will affect device reliability.

This device contains circuitry to protect the inputs and outputs against damage due to high static voltages or electric fields; however, it is advised that normal precautions be taken to avoid application of any voltage higher than absolute maximum-rated voltages to this high-impedance circuit.

All voltages listed are referenced to ground (GND).

Symbol	Parameter	Pin Name	Min.	Max.	Unit
V _{DD}	Supply Voltage	1	-15	28 ¹⁾	V
V _O	Output Voltage	3	-0.3	28 ¹⁾	V
I _O	Continuous Output On Current	3	-	50 ¹⁾	mA
T _J	Junction Temperature Range		-40	170 ²⁾	°C
¹⁾ as long as T _J max is not exceeded ²⁾ t < 1000 h					

3.4.1. Storage and Shelf Life

The permissible storage time (shelf life) of the sensors is unlimited, provided the sensors are stored at a maximum of 30 °C and a maximum of 85% relative humidity. At these conditions, no Dry Pack is required.

Solderability is guaranteed for one year from the date code on the package.

3.5. Recommended Operating Conditions

Functional operation of the device beyond those indicated in the “Recommended Operating Conditions/Characteristics” is not implied and may result in unpredictable behavior, reduce reliability and lifetime of the device.

All voltages listed are referenced to ground (GND).

Symbol	Parameter	Pin Name	Min.	Max.	Unit	Comment
V _{DD}	Supply Voltage	1	3.8	24	V	for HAL20y and HAL21y only
V _{DD}	Supply Voltage	1	4.3	24	V	for HAL22y only
I _O	Continuous Output on Current	3	0	20	mA	
V _O	Output Voltage (output switched off)	3	0	24	V	

3.6. Characteristics

at T_J = -40 °C to +140 °C, V_{DD} = 3.8 V to 24 V (**HAL22y: V_{DD} = 4.3 V to 24 V**), GND = 0 V
 at Recommended Operation Conditions if not otherwise specified in the column “Conditions”.
 Typical Characteristics for T_J = 25 °C and V_{DD} = 12 V.

Symbol	Parameter	Pin No.	Min.	Typ.	Max.	Unit	Conditions
I _{DD}	Supply Current over Temperature Range	1	1.6	3	5.2	mA	
V _{DDZ}	Overvoltage Protection at Supply	1	–	28.5	32	V	I _{DD} = 25 mA, T _J = 25 °C, t = 20 ms
V _{OZ}	Overvoltage Protection at Output	3	–	28	32	V	I _{OH} = 25 mA, T _J = 25 °C, t = 20 ms
V _{OL}	Output Voltage over Temperature Range	3	–	130	400	mV	I _{OL} = 20 mA
I _{OH}	Output Leakage Current over Temperature Range	3	–	–	10	μA	Output switched off, T _J ≤ 150 °C, V _{OH} = 3.8 to 24
f _{osc}	Internal Oscillator Chopper Frequency over Temperature Range	–	–	62	–	kHz	HAL20y, HAL21y, HAL22y
			–	140	–	kHz	HAL204
t _{en(O)}	Enable Time of Output after Setting of V _{DD}	1	–	35	–	μs	¹⁾ For HAL20y, HAL21y only
			–	70	–	μs	¹⁾ For HAL22y only
V _{reset}	Reset Voltage	1	–	3.8	–	V	For HAL22y only
t _r	Output Rise Time	3	–	75	400	ns	V _{DD} = 12 V, R _L = 820 Ohm, C _L = 20 pF
t _f	Output Fall Time	3	–	50	400	ns	

Symbol	Parameter	Pin No.	Min.	Typ.	Max.	Unit	Conditions
SOT89B Package							
R_{thja}	Thermal Resistance Junction to Ambient	–	–	–	212	K/W	Measured with a 1s0p board 30 mm x 10 mm x 1.5 mm, pad size (see Fig. 3–4)
R_{thjc}	Junction to Case	–	–	–	73	K/W	
TO92UA Package							
R_{thja}	Thermal Resistance Junction to Ambient	–	–	–	225	K/W	Measured with a 1s0p board
R_{thjc}	Junction to Case	–	–	–	63	K/W	
1) $V_{DD} = 12\text{ V}$, $B > B_{ON} + 2\text{ mT}$ or $B < B_{OFF} - 2\text{ mT}$ and $B > B_{OFF} + 2\text{ mT}$ or $B < B_{ON} - 2\text{ mT}$ for HAL 212							

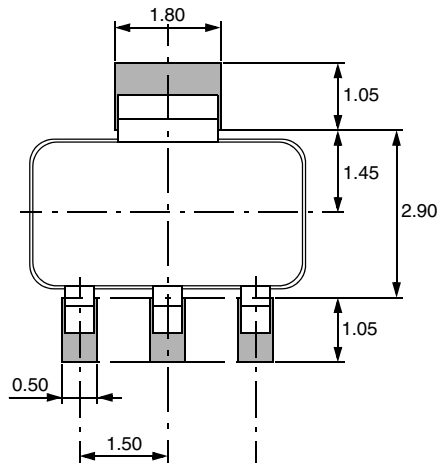

Fig. 3–4: Recommended footprint SOT89B-3,
Dimensions in mm
All dimensions are for reference only. The pad size may vary depending on the requirements of the soldering process.

3.7. Magnetic Characteristics Overview

at $T_J = -40\text{ °C}$ to $+140\text{ °C}$, $V_{DD} = 3.8\text{ V}$ to 24 V , (**HAL22y: $V_{DD} = 4.3\text{ V}$ to 24 V**)

Typical Characteristics for $V_{DD} = 12\text{ V}$. Magnetic flux density values of switching points.

Positive flux density values refer to the magnetic south pole at the branded side of the package.

Sensor Switching Type	Parameter T_J	On point B_{ON}			Off point B_{OFF}			Hysteresis B_{HYS}			Unit
		Min.	Typ.	Max.	Min.	Typ.	Max.	Min.	Typ.	Max.	
HAL201 unipolar	-40 °C	28	33	42	18	23	30	-	10.0	-	mT
	25 °C	28	34	42	18	24	30	-	10.0	-	mT
	140 °C	26	32	42	17.5	22	30	-	10.0	-	mT
HAL203 latching	-40 °C	5.5	8.4	12.5	-12.5	-8.6	-5.5	-	17	-	mT
	25 °C	5	7.6	11.5	-11.5	-7.6	-5	-	15.2	-	mT
	140 °C	3.5	6.7	11.0	-11.0	-6.4	-3.5	-	13.1	-	mT
HAL204 latching	-40 °C	10.5	15.8	21.5	-21.5	-15.8	-10.5	-	31.6	-	mT
	25 °C	10	14	18.5	-18.5	-14	-10	-	28	-	mT
	140 °C	6.0	10	15.5	-15.5	-10	-6.0	-	20	-	mT
HAL206 unipolar	-40 °C	8.8	12.5	18.0	4.5	7.0	11.0	-	5.5	-	mT
	25 °C	8.1	12.0	16.5	4.2	6.5	10.4	-	5.5	-	mT
	140 °C	7.4	10.0	16.0	3.4	6.0	9.9	-	4.0	-	mT
HAL207 unipolar	-40 °C	19.6	27.5	35.8	16.9	23.0	31.3	-	4.5	-	mT
	25 °C	19.6	26.5	35.0	16.9	22.5	30.6	-	4.0	-	mT
	140 °C	18.4	26.0	33.6	15.8	22.0	29.4	-	4.0	-	mT
HAL208 unipolar	-40 °C	13.1	17.5	25.0	11.9	15.7	23.0	-	1.8	-	mT
	25 °C	12.7	17.0	23.8	11.4	15.0	21.9	-	2.0	-	mT
	140 °C	10.8	14.6	23.0	9.7	13.0	21.0	-	1.6	-	mT
HAL210 unipolar	-40 °C	2.3	8.1	12.0	1.8	5.9	11.5	-	2.2	-	mT
	25 °C	2.3	7.9	12.0	1.8	5.7	11.5	-	2.2	-	mT
	140 °C	2.3	7.7	12.0	1.8	5.7	11.5	-	2.0	-	mT
HAL211 unipolar inverted	-40 °C	-11.5	-4.9	-1.8	-12.0	-7.4	-2.3	-	2.5	-	mT
	25 °C	-11.5	-5.2	-1.8	-12.0	-7.6	-2.3	-	2.4	-	mT
	140 °C	-11.5	-5.5	-1.8	-12.0	-7.7	-2.3	-	2.3	-	mT
HAL 212 unipolar	-40 °C	25.8	30.6	35.2	23.8	28.6	33.2	-	2.0	-	mT
	25 °C	24.1	28.9	34.5	22.3	27.1	32.7	-	1.8	-	mT
	140 °C	20.4	25.6	32.0	18.9	24.1	30.5	-	1.5	-	mT
HAL220 latching	-40 °C	0.5	2.8	6.5	-6.5	-2.8	-0.5	-	5.6	-	mT
	25 °C	0.5	2.6	6	-6	-2.6	-0.5	-	5.2	-	mT
	140 °C	0.3	2.4	5.5	-5.5	-2.4	-0.3	-	4.8	-	mT
HAL221 unipolar	-40 °C	13.0	19.0	23.0	7.5	12.0	17.5	-	7.0	-	mT
	25 °C	13.0	18.5	23.0	7.5	12.0	17.5	-	6.5	-	mT
	140 °C	13.0	17.5	23.0	7.5	11.5	17.5	-	6.0	-	mT

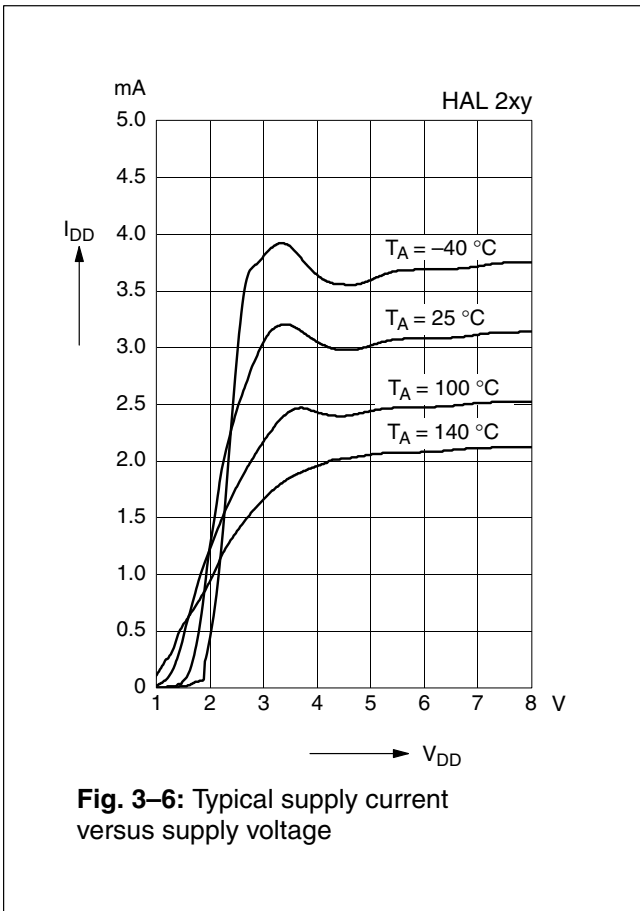
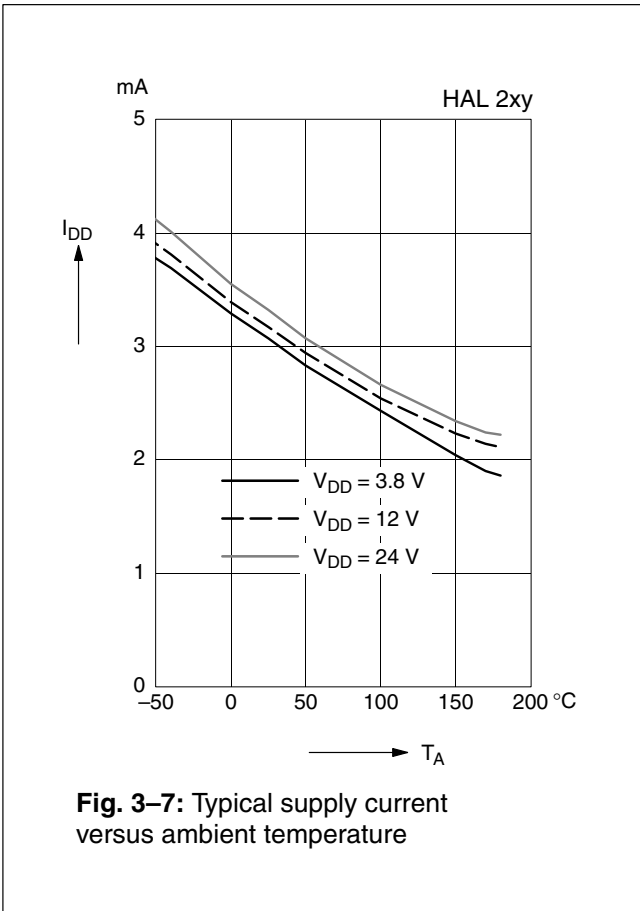
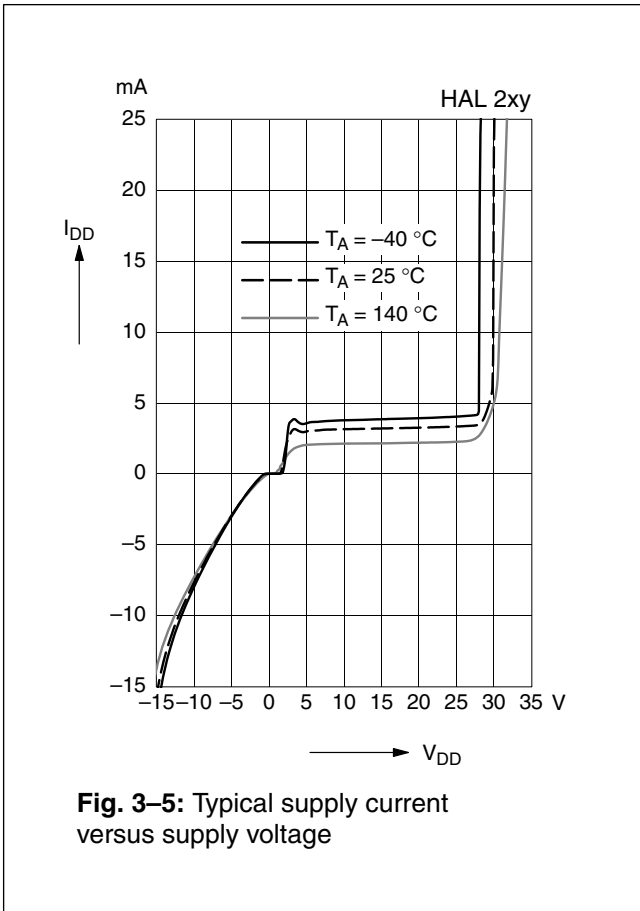

4. Application Notes

4.1. Ambient Temperature

Due to the internal power dissipation, the temperature on the silicon chip (junction temperature T_J) is higher than the temperature outside the package (ambient temperature T_A).

$$T_J = T_A + \Delta T$$

At static conditions and continuous operation, the following equation applies:

$$\Delta T = I_{DD} \times V_{DD} \times R_{th}$$

If $I_{OUT} > I_{DD}$, please contact Micronas application support for detailed instructions on calculating ambient temperature.

For typical values, use the typical parameters. For worst case calculation, use the max. parameters for I_{DD} and R_{th} , and the max. value for V_{DD} from the application.

For all sensors, the junction temperature range T_J is specified. The maximum ambient temperature T_{Amax} can be calculated as:

$$T_{Amax} = T_{Jmax} - \Delta T$$

4.2. HAL20y, HAL21y Operation

4.2.1. Extended Operating Conditions

All sensors fulfill the electrical and magnetic characteristics when operated within the Recommended Operating Conditions (see page 11).

Supply Voltage Below 3.8 V

Typically, the sensors operate with supply voltages above 3 V, however, below 3.8 V some characteristics may be outside the specification.

Note: The functionality of the sensor below 3.8 V is not tested. For special test conditions, please contact Micronas.

4.2.2. Start-up Behavior

Due to the active offset compensation, the sensors have an initialization time (enable time $t_{en(O)}$) after applying the supply voltage. The parameter $t_{en(O)}$ is specified in Section 3.6.: Characteristics on page 11.

During the initialization time, the output state is not defined and the output can toggle. After $t_{en(O)}$, the output will be low if the applied magnetic field B is above B_{ON} . The output will be high if B is below B_{OFF} . In case of sensors with an inverted switching behavior (HAL211), the output state will be high if $B > B_{OFF}$ and low if $B < B_{ON}$.

For magnetic fields between B_{OFF} and B_{ON} , the output state of the HAL sensor after applying V_{DD} will be either low or high. In order to achieve a well-defined output state, the applied magnetic field must be above B_{ONmax} , respectively, below B_{OFFmin} .

4.3. HAL22y Operation

4.3.1. Extended Operating Conditions

All sensors fulfill the electrical and magnetic characteristics when operated within the Recommended Operating Conditions (see page 11).

Supply Voltage Below 4.3 V

The devices contain a Power-on Reset (POR) and an undervoltage reset. For $V_{DD} < V_{reset}$ the output state is high. For $V_{reset} < V_{DD} < 4.3$ V the device responds to the magnetic field according to the specified magnetic characteristics.

Note: The functionality of the sensor below 4.3 V is not tested. For special test conditions, please contact Micronas.

4.3.2. Start-up Behavior

Due to the active offset compensation, the sensors have an initialization time (enable time $t_{en(O)}$) after applying the supply voltage. The parameter $t_{en(O)}$ is specified in Section 3.6.: Characteristics on page 11.

During the initialization time, the output state for the HAL22y is 'Off-state' (i.e. Output High). After $t_{en(O)}$, the output will high. The output will be switched to low if the magnetic field B is above B_{ON} .

4.4. EMC and ESD

For applications with disturbances on the supply line or radiated disturbances, a series resistor and a capacitor are recommended (see Fig. 4–1). The series resistor and the capacitor should be placed as closely as possible to the HAL sensor.

Applications with this arrangement passed the EMC tests according to the product standards ISO 7637.

Please contact Micronas for the detailed investigation reports with the EMC and ESD results.

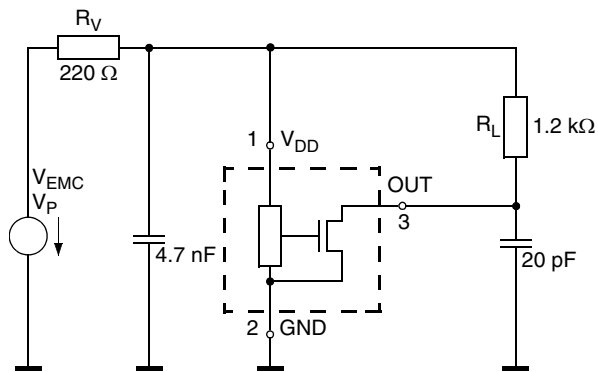

Fig. 4–1: Test circuit for EMC investigations

5. Data Sheet History

1. Advance Information: "HAL2xy Hall-Effect Sensor Family", June 21, 2006, 6251-703-1A1. First release of the advance information.
2. Advance Information: "HAL2xy Hall-Effect Sensor Family", Jan. 17, 2007, AI000007_002EN. Second release of the advance information. Major changes:
 - Type HAL220 added
3. Data Sheet: "HAL2xy Hall-Effect Sensor Family", Aug. 24, 2007, DSH000141_001EN. First release of the data sheet. Major changes:
 - Section 3.1. Outline Dimensions updated
 - Section 3.2. Dimensions of Sensitive Area updated
 - Section 3.6. Characteristics updated
 - Section 3.7. Magnetic Characteristics Overview updated
 - Type HAL206 added
 - Type HAL207 added
 - Type HAL221 added
4. Data Sheet: "HAL 2xy Hall-Effect Sensor Family", June 11, 2008, DSH000141_002EN. Second release of the data sheet. Major changes:
 - Type HAL208 added
 - Type HAL210 added
 - Section 3.1. Outline Dimensions: drawing TO92UA-5 (spread leads) removed
 - Section 3.7. Magnetic Characteristics Overview: HAL 221 and values for hysteresis B_{HYS} updated
5. Data Sheet: "HAL 2xy Hall-Effect Sensor Family", Jan. 11, 2010, DSH000141_003EN. Third release of the data sheet. Major changes:
 - Type HAL 211 added
 - Type HAL 212 added
 - Explanation on page 5 added: "Unipolar Switching Sensors with Inverted Output Sensitive to North Pole"
6. Data Sheet: "HAL 2xy Hall-Effect Sensor Family", Sept. 8, 2011, DSH000141_004EN. Fourth release of the data sheet. Major changes:
 - Type HAL 202 removed (separate Data Sheet HAL 202 available)