

Data Sheet

HAL[®] 1xy

Hall-Effect Switch IC Family

Copyright, Warranty, and Limitation of Liability

The information and data contained in this document are believed to be accurate and reliable. The software and proprietary information contained therein may be protected by copyright, patent, trademark and/or other intellectual property rights of Micronas. All rights not expressly granted remain reserved by Micronas.

Micronas assumes no liability for errors and gives no warranty representation or guarantee regarding the suitability of its products for any particular purpose due to these specifications.

By this publication, Micronas does not assume responsibility for patent infringements or other rights of third parties which may result from its use. Commercial conditions, product availability and delivery are exclusively subject to the respective order confirmation.

Any information and data which may be provided in the document can and do vary in different applications, and actual performance may vary over time.

All operating parameters must be validated for each customer application by customers' technical experts. Any new issue of this document invalidates previous issues. Micronas reserves the right to review this document and to make changes to the document's content at any time without obligation to notify any person or entity of such revision or changes. For further advice please contact us directly.

Do not use our products in life-supporting systems, aviation, and aerospace applications! Unless explicitly agreed to otherwise in writing between the parties, Micronas' products are not designed, intended or authorized for use as components in systems intended for surgical implants into the body, or other applications intended to support or sustain life, or for any other application in which the failure of the product could create a situation where personal injury or death could occur.

No part of this publication may be reproduced, photocopied, stored on a retrieval system or transmitted without the express written consent of Micronas.

Micronas Trademarks

– HAL

Micronas Trademarks

Choppered Offset Compensation protected by Micronas patents no. US5260614, US5406202, EP0525235 and EP0548391.

Third-Party Trademarks

All other brand and product names or company names may be trademarks of their respective companies.

Contents

Page	Section	Title
4	1.	Introduction
4	1.1.	Family Overview
5	1.2.	Marking Code
5	1.3.	Operating Junction Temperature Range
5	1.4.	Solderability and Welding
6	2.	Specifications
6	2.1.	Outline Dimensions
8	2.2.	Positions of Sensitive Areas
8	2.3.	Absolute Maximum Ratings
8	2.4.	Recommended Operating Conditions
9	2.5.	Characteristics
10	2.6.	Magnetic Characteristics Overview
11	3.	Application Notes
11	3.1.	Ambient Temperature
11	3.2.	Extended Operating Conditions
11	3.3.	Start-up Behavior
11	3.4.	EMC and ESD
12	4.	Data Sheet History

Hall-Effect Switch IC Family

Note: The HAL 1xy family has been designed for commercial and industrial applications. It is not intended to be used in automotive or automotive-like applications.

1. Introduction

The HAL 1xy Hall switch family is produced in CMOS technology. The sensors include a temperature-compensated Hall plate with active offset compensation, a comparator, and an open-drain output transistor. The comparator compares the actual magnetic flux through the Hall plate (Hall voltage) with the fixed reference values (switching points). Accordingly, the output transistor is switched on or off.

The active offset compensation leads to magnetic parameters which are robust against mechanical stress effects. In addition, the magnetic characteristics are constant in the full supply voltage and temperature range.

The HAL 1xy family is available in the SMD-package SOT89B-3 and in the leaded version TO92UA-6.

1.1. Family Overview

This sensor family consists of sensors with a latching and unipolar output behavior.

Type	Switching Behavior	Sensitivity	see Page
101	unipolar	low	10
102	latching	high	10
103	latching	medium	10
104	latching	low	10
106	unipolar	high	10
107	unipolar	low	10
108	unipolar	medium	10
109	unipolar	high	10

Unipolar Sensors:

The output turns low with the magnetic south pole on the branded side of the package and turns high if the magnetic field is removed. The sensor does not respond to the magnetic north pole on the branded side.

Latching Sensors:

The sensors have a latching behavior and require a magnetic north and south pole for correct functioning. The output turns low with the magnetic south pole on the branded side of the package and turns high with the magnetic north pole on the branded side. The output does not change if the magnetic field is removed. For changing the output state, the opposite magnetic field polarity must be applied.

1.2. Marking Code

All Hall sensors have a marking on the package surface (branded side). This marking includes the name of the sensor and the temperature range.

Type	Temperature Range	
	I	C
HAL101	101I	101C
HAL102	102I	102C
HAL103	103I	103C
HAL104	104I	104C
HAL106	106I	106C
HAL107	107I	107C
HAL108	108I	108C
HAL109	109I	109C

1.3. Operating Junction Temperature Range

The Hall sensors from Micronas are specified to the chip temperature (junction temperature T_J).

I: $T_J = -20\text{ °C to }+125\text{ °C}$

C: $T_J = 0\text{ °C to }+85\text{ °C}$

Hall Sensor Package Codes

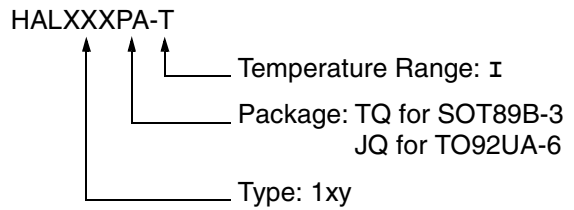

Example: **HAL102JQ-I**

- Type: 102
- Package: TO92UA-6
- Temperature Range: $T_J = -20\text{ °C to }+125\text{ °C}$

Hall sensors are available in a wide variety of packaging versions and quantities. For more detailed information, please refer to the brochure: "Hall Sensors. Ordering Codes, Packaging, Handling".

1.4. Solderability and Welding

Soldering

During soldering reflow processing and manual reworking, a component body temperature of 260 °C should not be exceeded.

Welding

Device terminals shall be compatible with laser and electrical welding. Please, note that the success of the welding process is subject to different welding parameters which will vary according to the welding technique used. A very close control of the welding parameters is absolutely necessary in order to reach satisfying results. Micronas, therefore, does not give any implied or express warranty as to the ability to weld the component.

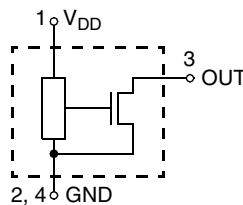

Fig. 1-1: Pin configuration

2. Specifications

2.1. Outline Dimensions

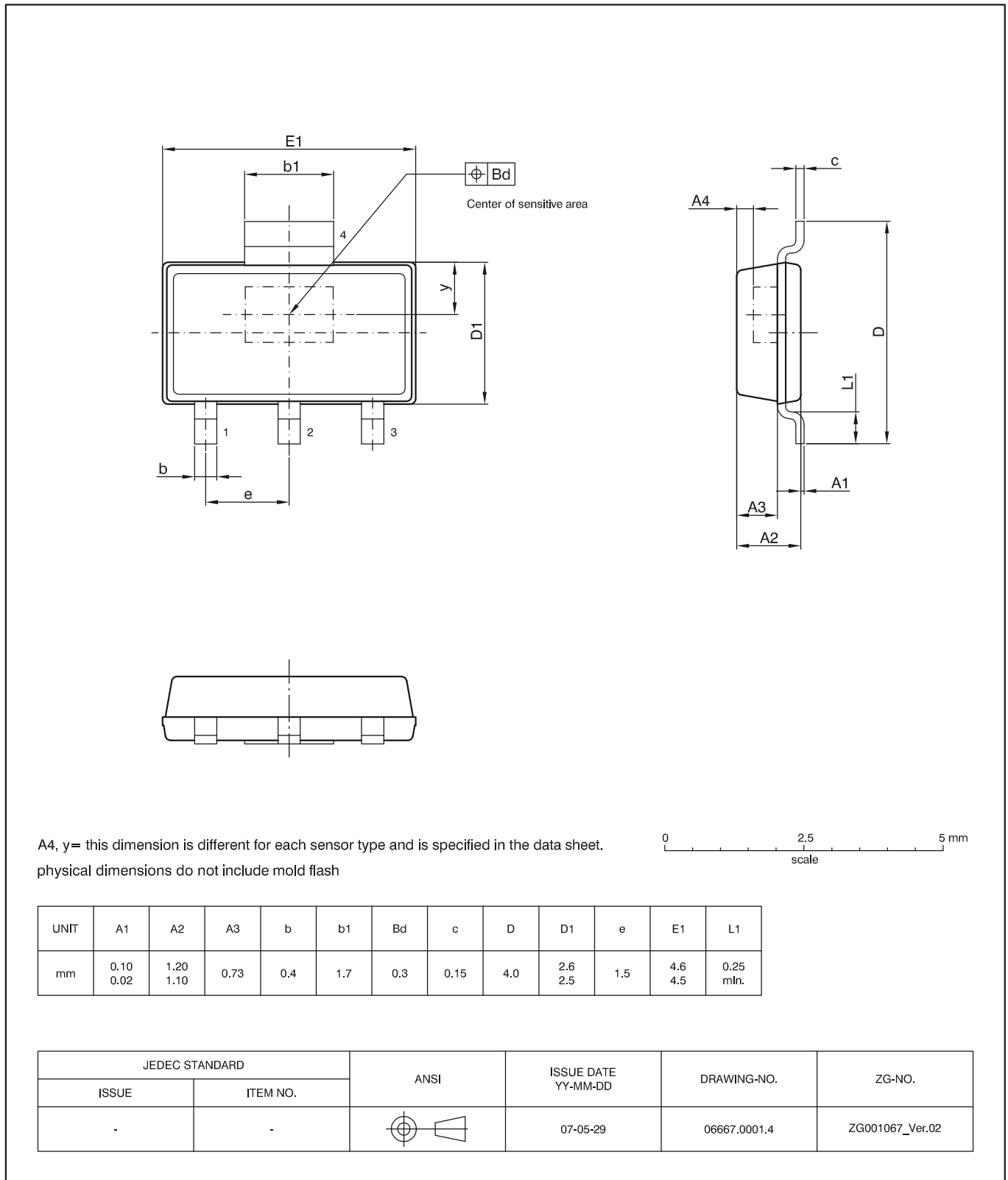

Fig. 2-1:
SOT89B-3: Plastic **S**mall **O**utline **T**ransistor package, 4 leads, with one sensitive area
 Weight approximately 0.034 g.

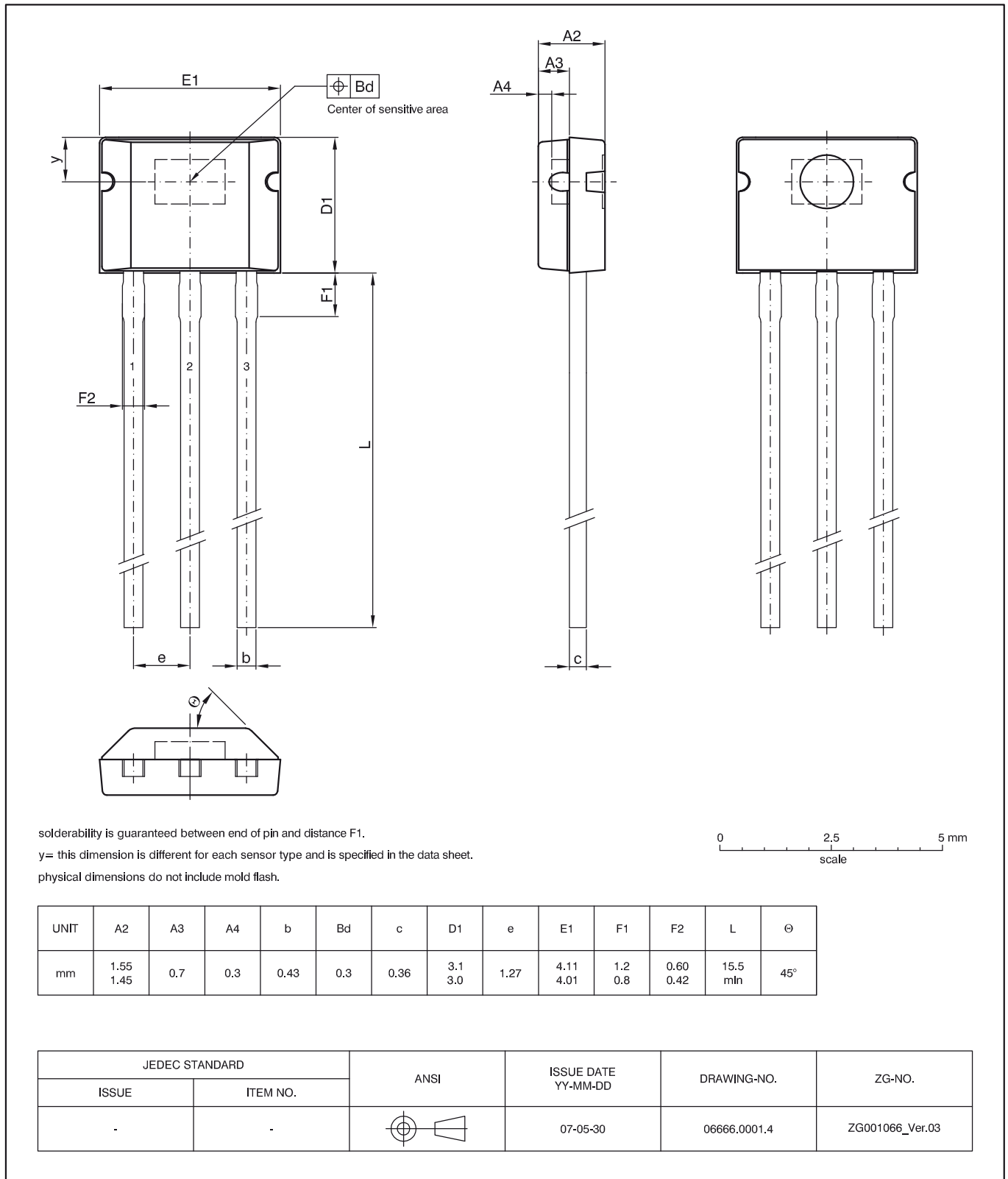

Fig. 2-2:
TO92UA-6: Plastic Transistor Standard UA package, 3 leads
 Weight approximately 0.106 g

2.2. Positions of Sensitive Areas

	SOT89B-3	TO92UA-6
y	0.95 mm nominal	1.08 mm nominal
A4	0.33 mm nominal	0.30 mm nominal

2.3. Absolute Maximum Ratings

Stresses beyond those listed in the “Absolute Maximum Ratings” may cause permanent damage to the device. This is a stress rating only. Functional operation of the device at these conditions is not implied. Exposure to absolute maximum rating conditions for extended periods will affect device reliability.

This device contains circuitry to protect the inputs and outputs against damage due to high static voltages or electric fields; however, it is advised that normal precautions be taken to avoid application of any voltage higher than absolute maximum-rated voltages to this high-impedance circuit.

All voltages listed are referenced to ground (GND).

Symbol	Parameter	Pin Name	Min.	Max.	Unit
V_{DD}	Supply Voltage	1	-15	28 ¹⁾	V
V_O	Output Voltage	3	-0.3	28 ¹⁾	V
I_O	Continuous Output On Current	3	-	50 ¹⁾	mA
T_J	Junction Temperature Range		-40	140 ²⁾	°C
¹⁾ as long as T_{Jmax} is not exceeded ²⁾ $t < 1000$ h					

2.4. Recommended Operating Conditions

Functional operation of the device beyond those indicated in the “Recommended Operating Conditions/Characteristics” is not implied and may result in unpredictable behavior, reduce reliability and lifetime of the device.

All voltages listed are referenced to ground (GND).

Symbol	Parameter	Pin Name	Min.	Max.	Unit	Comment
V_{DD}	Supply Voltage	1	3.8	24	V	
I_O	Continuous Output on Current	3	0	20	mA	
V_O	Output Voltage (output switched off)	3	0	24	V	

2.5. Characteristics

at $T_J = -20\text{ }^\circ\text{C}$ to $+125\text{ }^\circ\text{C}$, $V_{DD} = 3.8\text{ V}$ to 24 V , $\text{GND} = 0\text{ V}$

at Recommended Operation Conditions if not otherwise specified in the column "Conditions".

Typical Characteristics for $T_J = 25\text{ }^\circ\text{C}$ and $V_{DD} = 12\text{ V}$.

Symbol	Parameter	Pin No.	Min.	Typ.	Max.	Unit	Conditions
I_{DD}	Supply Current over Temperature Range	1	1.6	3	5.2	mA	
V_{DDZ}	Overshoot Protection at Supply	1	-	28.5	32	V	$I_{DD} = 25\text{ mA}$, $T_J = 25\text{ }^\circ\text{C}$, $t = 20\text{ ms}$
V_{OZ}	Overshoot Protection at Output	3	-	28	32	V	$I_{OH} = 25\text{ mA}$, $T_J = 25\text{ }^\circ\text{C}$, $t = 20\text{ ms}$
V_{OL}	Output Voltage over Temperature Range	3	-	130	400	mV	$I_{OL} = 20\text{ mA}$
I_{OH}	Output Leakage Current over Temperature Range	3	-	-	10	μA	Output switched off, $T_J \leq 150\text{ }^\circ\text{C}$, $V_{OH} = 3.8\text{ to }24\text{ V}$
f_{osc}	Internal Oscillator Chopper Frequency over Temperature Range			62	-	kHz	HAL 10y, HAL 11y
				140	-	kHz	HAL 104
$t_{en(O)}$	Enable Time of Output after Setting of V_{DD}	1	-	35	-	μs	
t_r	Output Rise Time	3	-	75	400	ns	$V_{DD} = 12\text{ V}$, $R_L = 820\text{ Ohm}$, $C_L = 20\text{ pF}$
t_f	Output Fall Time	3	-	50	400	ns	
SOT89B Package							
R_{thja}	Thermal Resistance Junction to Ambient	-	-	-	212	K/W	Measured with a 1s0p board 30 mm x 10 mm x 1.5 mm, pad size (see Fig. 2-3)
R_{thjc}	Junction to Case	-	-	-	73	K/W	
TO92UA Package							
R_{thja}	Thermal Resistance Junction to Ambient	-	-	-	225	K/W	Measured with a 1s0p board
R_{thjc}	Junction to Case	-	-	-	63	K/W	
1) $V_{DD} = 12\text{ V}$, $B > B_{ON} + 2\text{ mT}$ or $B < B_{OFF} - 2\text{ mT}$							

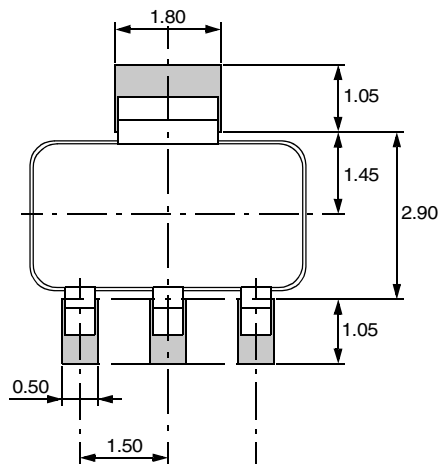

Fig. 2-3: Recommended footprint SOT89B-3, Dimensions in mm
All dimensions are for reference only. The pad size may vary depending on the requirements of the soldering process.

2.6. Magnetic Characteristics Overview

at $T_J = -20\text{ °C}$ to $+125\text{ °C}$, $V_{DD} = 3.8\text{ V}$ to 24 V ,

Typical Characteristics for $V_{DD} = 12\text{ V}$. Magnetic flux density values of switching points.

Positive flux density values refer to the magnetic south pole at the branded side of the package.

Sensor Switching Type	Parameter T_J	On point B_{ON}			Off point B_{OFF}			Hysteresis B_{HYS}			Unit
		Min.	Typ.	Max.	Min.	Typ.	Max.	Min.	Typ.	Max.	
HAL101 unipolar	-20 °C	28	33	42	18	23	30	-	10.0	-	mT
	25 °C	28	34	42	18	24	30	-	10.0	-	mT
	125 °C	26	32	42	17.5	22	30	-	10.0	-	mT
HAL102 latching	-20 °C	0.5	2.8	6.5	-6.5	-2.8	-0.5	-	5.6	-	mT
	25 °C	0.5	2.6	6	-6	-2.6	-0.5	-	5.2	-	mT
	125 °C	0.1	2.4	5.5	-5.5	-2.4	-0.1	-	4.8	-	mT
HAL103 latching	-20 °C	5.5	8.4	12.5	-12.5	-8.6	-5.5	-	17	-	mT
	25 °C	5	7.6	11.5	-11.5	-7.6	-5	-	15.2	-	mT
	125 °C	3.5	6.7	11.0	-11.0	-6.4	-3.5	-	13.1	-	mT
HAL104 latching	-20 °C	10.5	15.8	21.5	-21.5	-15.8	-10.5	-	31.6	-	mT
	25 °C	10	14	18.5	-18.5	-14	-10	-	28	-	mT
	125 °C	6.0	10	15.5	-15.5	-10	-6.0	-	20	-	mT
HAL106 unipolar	-20 °C	8.8	12.5	18.0	4.5	7.0	11.0	-	5.5	-	mT
	25 °C	8.1	12.0	16.5	4.2	6.5	10.4	-	5.5	-	mT
	125 °C	7.4	10.0	16.0	3.4	6.0	9.9	-	4.0	-	mT
HAL107 unipolar	-20 °C	19.6	27.5	35.8	16.9	23.0	31.3	-	4.5	-	mT
	25 °C	19.6	26.5	35.0	16.9	22.5	30.6	-	4.0	-	mT
	125 °C	18.4	26.0	33.6	15.8	22.0	29.4	-	4.0	-	mT
HAL108 unipolar	-20 °C	13.1	17.5	25.0	11.9	15.7	23.0	-	1.8	-	mT
	25 °C	12.7	17.0	23.8	11.4	15.0	21.9	-	2.0	-	mT
	125 °C	10.8	14.6	23.0	9.7	13.0	21.0	-	1.6	-	mT
HAL109 unipolar	-20 °C	2.3	8.1	12.0	1.8	5.9	11.5	-	2.2	-	mT
	25 °C	2.3	7.9	12.0	1.8	5.7	11.5	-	2.2	-	mT
	125 °C	2.3	7.7	12.0	1.8	5.7	11.5	-	2.0	-	mT

3. Application Notes

3.1. Ambient Temperature

Due to the internal power dissipation, the temperature on the silicon chip (junction temperature T_J) is higher than the temperature outside the package (ambient temperature T_A).

$$T_J = T_A + \Delta T$$

At static conditions and continuous operation, the following equation applies:

$$\Delta T = I_{DD} \times V_{DD} \times R_{th}$$

If $I_{OUT} > I_{DD}$, please contact Micronas application support for detailed instructions on calculating ambient temperature.

For typical values, use the typical parameters. For worst case calculation, use the max. parameters for I_{DD} and R_{th} , and the max. value for V_{DD} from the application.

For all sensors, the junction temperature range T_J is specified. The maximum ambient temperature T_{Amax} can be calculated as:

$$T_{Amax} = T_{Jmax} - \Delta T$$

3.2. Extended Operating Conditions

All sensors fulfill the electrical and magnetic characteristics when operated within the Recommended Operating Conditions (see page 8).

Supply Voltage Below 3.8 V

Typically, the sensors operate with supply voltages above 3 V, however, below 3.8 V some characteristics may be outside the specification.

Note: The functionality of the sensor below 3.8 V is not tested. For special test conditions, please contact Micronas.

3.3. Start-up Behavior

Due to the active offset compensation, the sensors have an initialization time (enable time $t_{en(O)}$) after applying the supply voltage. The parameter $t_{en(O)}$ is specified in Section 2.5.: Characteristics on page 9.

During the initialization time, the output state is not defined and the output can toggle. After $t_{en(O)}$, the output will be low if the applied magnetic field B is above B_{ON} . The output will be high if B is below B_{OFF} .

For magnetic fields between B_{OFF} and B_{ON} , the output state of the HAL sensor after applying V_{DD} will be either low or high. In order to achieve a well-defined output state, the applied magnetic field must be above B_{ONmax} , respectively, below B_{OFFmin} .

3.4. EMC and ESD

For applications with disturbances on the supply line or radiated disturbances, a series resistor and a capacitor are recommended (see Fig. 3–1). The series resistor and the capacitor should be placed as closely as possible to the HAL sensor.

Please contact Micronas for the detailed investigation reports with the EMC and ESD results.

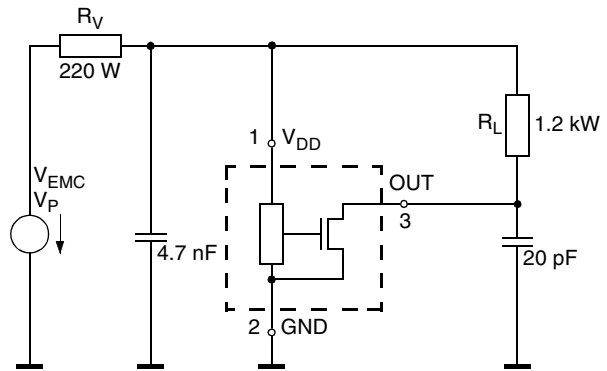

Fig. 3–1: Test circuit for EMC investigations

4. Data Sheet History

1. Data Sheet: "HAL 1xy Hall-Effect Switch IC Family", April 8, 2009, DSH000150_001EN. First release of the data sheet.