

Product Specifications		
PART NO.:	VL33B2K60A-K9/F8S	REV: 1.0

General Information

16GB 2Gx72 DDR3 SDRAM ECC REGISTERED DIMM 240-PIN

Description

The VL33B2K60A is a 2Gx72 DDR3 SDRAM high density RDIMM. This memory module is dual rank, consists of thirty-six CMOS 1Gx4 bits with 8 banks DDR3 synchronous DRAMs in BGA packages, a 28-bit registered buffer/PLL clock in BGA package, and a 2K EEPROM in an 8-pin MLF package. This module is a 240-pin registered dual in-line memory module and is intended for mounting into an edge connector socket. Decoupling capacitors are mounted on the printed circuit board for each DDR3 SDRAM.

Features

- 240-pin, registered dual in-line memory module (RDIMM)
- Supports ECC error detection and correction
- Fast data transfer rates: PC3-10600, PC3-8500
- VDD = VDDQ = 1.5V +/-0.075V
- JEDEC standard 1.5V +/-0.075V I/O (SSTL_15)
- VDDSPD = 3.0V to 3.6V
- Eight internal component banks for concurrent operation
- 8-bit pre-fetch architecture
- Bi-directional Differential Data-Strobe
- Nominal and dynamic on-die termination (ODT)
- ZQ calibration support
- Programmable CAS# latency: 9 (DDR3-1333), 7 (DDR3-1066)
- Programmable burst; length (8)
- Average refresh period 7.8 us
- Asynchronous reset
- Fly-by topology
- On board terminated command, address, and control bus
- Serial presence detect (SPD) with EEPROM
- Gold edge contacts
- JEDEC pinout
- Lead-free, RoHS compliant
- PCB: Height 30.00mm (1.181”), double sided components

Pin Description

Pin Name	Function
A0~A15	Address Inputs
A10/AP	Address Input/ Autoprecharge
A12/BC#	Address Input/ Burst Chop
BA0~BA2	Bank Address Inputs
DQ0~DQ63	Data Input/Output
DQS0~DQS17	Data Strobes
DQS0#~DQS17#	Data Strobes Complement
CB0~CB7	Data Check Bits I/O
PAR_IN	Parity Input
ERR_OUT#	Parity Error Output
CK0, CK0#	Clock Input
ODT0, ODT1	On-die Termination Control
CKE0, CKE1	Clock Enables
CS0#~CS1#	Chip Selects
RAS#	Row Address Strobes
CAS#	Column Address Strobes
WE#	Write Enable
VDD	Voltage Supply
VSS	Ground
SA0~SA2	SPD Address
SDA	SPD Data Input/Output
SCL	SPD Clock Input
VREFCA	Reference Voltage for CA
VREFDQ	Reference Voltage for DQ
VDDSPD	SPD Voltage Supply
VTT	Termination Voltage
RESET#	Register and SDRAM Control
NC	No Connect

Order Information:

VL33B2K60A-K9 S X

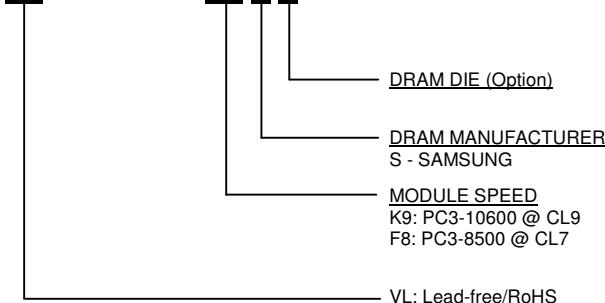



Product Specifications

PART NO.:

VL33B2K60A-K9/F8S

REV: 1.0

Pin Configuration

240-PIN DDR3 RDIMM FRONT SIDE								240-PIN DDR3 RDIMM BACK SIDE							
Pin	Name	Pin	Name	Pin	Name	Pin	Name	Pin	Name	Pin	Name	Pin	Name		
1	VREFDQ	31	DQ25	61	A2	91	DQ41	121	VSS	151	VSS	181	A1	211	VSS
2	VSS	32	VSS	62	VDD	92	VSS	122	DQ4	152	DQS12	182	VDD	212	DQS14
3	DQ0	33	DQS3#	63	CK1 *	93	DQS5#	123	DQ5	153	DQS12#	183	VDD	213	DQS14#
4	DQ1	34	DQS3	64	CK1# *	94	DQS5	124	VSS	154	VSS	184	CK0	214	VSS
5	VSS	35	VSS	65	VDD	95	VSS	125	DQS9	155	DQ30	185	CK0#	215	DQ46
6	DQS0#	36	DQ26	66	VDD	96	DQ42	126	DQS9#	156	DQ31	186	VDD	216	DQ47
7	DQS0	37	DQ27	67	VREFCA	97	DQ43	127	VSS	157	VSS	187	EVENT# *	217	VSS
8	VSS	38	VSS	68	PAR_IN	98	VSS	128	DQ6	158	CB4	188	A0	218	DQ52
9	DQ2	39	CB0	69	VDD	99	DQ48	129	DQ7	159	CB5	189	VDD	219	DQ53
10	DQ3	40	CB1	70	A10/AP	100	DQ49	130	VSS	160	VSS	190	BA1	220	VSS
11	VSS	41	VSS	71	BA0	101	VSS	131	DQ12	161	DQS17	191	VDD	221	DQS15
12	DQ8	42	DQS8#	72	VDD	102	DQS6#	132	DQ13	162	DQS17#	192	RAS#	222	DQS15#
13	DQ9	43	DQS8	73	WE#	103	DQS6	133	VSS	163	VSS	193	CS0#	223	VSS
14	VSS	44	VSS	74	CAS#	104	VSS	134	DQS10	164	CB6	194	VDD	224	DQ54
15	DQS1#	45	CB2	75	VDD	105	DQ50	135	DQS10#	165	CB7	195	ODT0	225	DQ55
16	DQS1	46	CB3	76	CS1#	106	DQ51	136	VSS	166	VSS	196	A13	226	VSS
17	VSS	47	VSS	77	ODT1	107	VSS	137	DQ14	167	TEST *	197	VDD	227	DQ60
18	DQ10	48	VTT	78	VDD	108	DQ56	138	DQ15	168	RESET#	198	CS3# *	228	DQ61
19	DQ11	49	VTT	79	CS2# *	109	DQ57	139	VSS	169	CKE1	199	VSS	229	VSS
20	VSS	50	CKE0	80	VSS	110	VSS	140	DQ20	170	VDD	200	DQ36	230	DQS16
21	DQ16	51	VDD	81	DQ32	111	DQS7#	141	DQ21	171	A15	201	DQ37	231	DQS16#
22	DQ17	52	BA2	82	DQ33	112	DQS7	142	VSS	172	A14	202	VSS	232	VSS
23	VSS	53	ERR_OUT#	83	VSS	113	VSS	143	DQS11	173	VDD	203	DQS13	233	DQ62
24	DQS2#	54	VDD	84	DQS4#	114	DQ58	144	DQS11#	174	A12/ BC#	204	DQS13#	234	DQ63
25	DQS2	55	A11	85	DQS4	115	DQ59	145	VSS	175	A9	205	VSS	235	VSS
26	VSS	56	A7	86	VSS	116	VSS	146	DQ22	176	VDD	206	DQ38	236	VDDSPD
27	DQ18	57	VDD	87	DQ34	117	SA0	147	DQ23	177	A8	207	DQ39	237	SA1
28	DQ19	58	A5	88	DQ35	118	SCL	148	VSS	178	A6	208	VSS	238	SDA
29	VSS	59	A4	89	VSS	119	SA2	149	DQ28	179	VDD	209	DQ44	239	VSS
30	DQ24	60	VDD	90	DQ40	120	VTT	150	DQ29	180	A3	210	DQ45	240	VTT

*: These pins are not used in this module.



Product Specifications		
PART NO.:	VL33B2K60A-K9/F8S	REV: 1.0

Absolute Maximum Ratings					
Symbol	Parameter	MIN	MAX	Unit	
VDD	Voltage on VDD pin relative to VSS	-0.4	1.975	V	
VDDQ	Voltage on VDDQ pin relative to VSS	-0.4	1.975	V	
VIN, VOUT	Voltage on any pin relative to VSS	-0.4	1.975	V	
TSTG	Storage temperature	-55	100	°C	
IL	Input leakage current; Any input 0V<VIN<VDD; VREF input 0V<VIN<0.95V; Other pins not under test = 0V	Address, BA, RAS#, CAS#,WE#, CS#, CKE, ODT	-5	5	uA
		CK, CK#	-5	150	uA
IOZ	Output leakage current; 0V<VOUT<VDDQ; DQs and ODT are disabled	DQ, DQS, DQS#	-10	10	uA
IVREF	VREF supply leakage current; VREF = Valid VREF level	-72	72	uA	

DC Operating Conditions						
Symbol	Parameter	Min	Typical	Max	Unit	Notes
VDD	Supply Voltage	1.425	1.5	1.575	V	1,2
VDDQ	I/O Supply Voltage	1.425	1.5	1.575	V	1,2
VREFDQ (DC)	I/O reference voltage DQ bus	0.49 x VDD	0.5 x VDD	0.51 x VDD	V	3,4
VREFCA (DC)	Input reference voltage CMD/ADD bus	0.49 x VDD	0.5 x VDD	0.51 x VDD	V	3,4
VTT	Termination Reference Voltage	-0.483 x VDDQ	0.5 x VDDQ	+0.517 x VDDQ	V	5

Note:

1. Under all conditions VDDQ must be less than or equal to VDD.
2. VDDQ tracks with VDD. AC parameters are measured with VDD and VDDQ tied together.
3. The AC peak noise on VREF may not allow VREF to deviate from VREF(DC) by more than +/-1% VDD
4. For reference: approximate VDD/2 +/-15mV.
5. VTT termination voltage in excess of stated limit will adversely affect the command and address signals' voltage margin and will reduce timing margins.

Operating Temperature Condition				
Symbol	Parameter	Rating	Units	Notes
TOPER	Operating temperature	0 - 95	°C	1,2

Notes:

1. Operating temperature is the case surface temperature on the center/top side of the DRAM. For the measurement conditions, please refer to JEDEC JESD51-2.
2. At 0 - 85°C, operation temperature range, all DRAM specifications will be supported. The refresh rate is required to double when 85°C < TOPER <= 95°C.



Product Specifications		
PART NO.:	VL33B2K60A-K9/F8S	REV: 1.0

Input DC Logic Level				
All voltages referenced to VSS				
Symbol	Parameter	Min	Max	Unit
Command and Address				
VIHCA(DC)	Input High (Logic 1) Voltage DDR3-1066/1333	VREF + 0.100	VDD	V
VILCA(DC)	Input Low (Logic 0) Voltage DDR3-1066/1333	VSS	VREF - 0.100	V
DQ and DM				
VIHDQ(DC)	Input High (Logic 1) Voltage DDR3-1066/1333	VREF + 0.100	VDD	V
VILDQ(DC)	Input Low (Logic 0) Voltage DDR3-1066/1333	VSS	VREF - 0.100	V

Input AC Logic Level				
All voltages referenced to VSS				
Symbol	Parameter	Min	Max	Unit
Command and Address				
VIHCA(AC)	Input High (Logic 1) Voltage DDR3-1066/1333	VREF + 0.175	-	V
VILCA(AC)	Input Low (Logic 0) Voltage DDR3-1066/1333	-	VREF - 0.175	V
DQ and DM				
VIHDQ(AC)	Input High (Logic 1) Voltage DDR3-1066	VREF + 0.175	-	V
VILDQ(AC)	Input Low (Logic 0) Voltage DDR3-1066	-	VREF - 0.175	V
VIHDQ(AC)	Input High (Logic 1) Voltage DDR3-1333	VREF + 0.150	-	V
VILDQ(AC)	Input Low (Logic 0) Voltage DDR3-1333	-	VREF - 0.150	V

Input/Output Capacitance						
TA=25°C, f=100MHz						
Parameter	Symbol	K9 (DDR3-1333)		F8 (DDR3-1066)		Unit
		Min	Max	Min	Max	
Input capacitance (A0~A15, BA0~BA2, RAS#, CAS#, WE#)	CIN1	5.5	6.5	5.5	6.5	pF
Input capacitance (CKE0, CKE1), (ODT0, ODT1), (CS0# ~CS1#)	CIN2	5.5	6.5	5.5	6.5	pF
Input capacitance (CK0, CK0#)	CIN3	5.5	6.5	5.5	6.5	pF
Input/Output capacitance (DQ, DQS, DQS#, CB)	CIO	7	9	7	9.4	pF

Product Specifications

PART NO.:
VL33B2K60A-K9/F8S
REV: 1.0

IDD Specification

Condition	Symbol	K9 (DDR3-1333)	F8 (DDR3-1066)	Unit
Operating one bank active-precharge current; tCK= tCK(IDD); tRC= tRC(IDD); tRAS= tRAS MIN(IDD); CKE is HIGH, CS# is HIGH between valid commands; Address bus inputs are SWITCHING; Data bus inputs are SWITCHING	IDD0*	1360	1270	mA
Operating one bank active-read-precharge current; IOU _T = 0mA; BL = 8; CL = CL(IDD); AL = 0; tCK= tCK(IDD); tRC= tRC(IDD); tRAS= tRAS MIN(IDD); tRCD= tRCD(IDD); CKE is HIGH, CS# is HIGH between valid commands; Address bus inputs are SWITCHING; Data pattern is same as IDD4W.	IDD1*	1540	1450	mA
Precharge power-down current; All device banks idle; tCK= tCK(IDD); CKE is LOW; Other control and address bus inputs are STABLE; Data bus inputs are FLOATING	IDD2P-F**	820	820	mA
	IDD2P-S**	640	640	mA
Precharge standby current; All device banks idle; tCK= tCK(IDD); CKE is HIGH; CS# is HIGH; Other control and address bus inputs are SWITCHING; Data bus inputs are SWITCHING.	IDD2N**	1180	1000	mA
Precharge quiet standby current; All device banks idle; tCK= tCK(IDD); CKE is HIGH; CS# is HIGH; Other control and address bus inputs are STABLE; Data bus inputs are FLOATING	IDD2Q**	1000	1000	mA
Active power-down current; All device banks open; tCK= tCK(IDD); CKE is LOW; Other control and address bus inputs are STABLE; Data bus inputs are FLOATING.	IDD3P**	1000	1000	mA
Active standby current; All device banks open; tCK= tCK(IDD); tRP= tRP(IDD); tRAS= tRAS MAX(IDD); CKE is HIGH, CS# is HIGH between valid commands; Other control and address bus inputs are SWITCHING; Data bus inputs are SWITCHING.	IDD3N**	1720	1540	mA
Operating burst read current; All device banks open; Continuous burst reads; IOU _T = 0mA; BL = 8; CL = CL(IDD); AL = 0; tCK= tCK(IDD); tRAS= tRAS MAX(IDD); tRP= tRP(IDD); CKE is HIGH, CS# is HIGH between valid commands; Address bus inputs are SWITCHING; Data pattern is same as IDD4W.	IDD4R*	2080	1810	mA
Operating burst write current; All device banks open; Continuous burst writes; BL = 8; CL = CL(IDD); AL = 0; tCK= tCK(IDD); tRAS= tRAS MAX(IDD); tRP= tRP(IDD); CKE is HIGH, CS# is HIGH between valid commands; Address bus inputs are SWITCHING; Data bus inputs are SWITCHING.	IDD4W*	2260	1990	mA
Burst refresh current; tCK=tCK(IDD); Refresh command at every tRFC(IDD) interval; CKE is HIGH; CS# is HIGH between valid commands; Other control and address bus inputs are SWITCHING; Data bus inputs are SWITCHING.	IDD5**	6220	5500	mA
Self refresh current; CK and CK# at 0V; CKE < 0.2V; Other control and address bus inputs are FLOATING; Data bus inputs are FLOATING.	IDD6**	540	540	mA
Operating bank interleave read current; All bank interleaving reads; IOU _T = 0mA; BL = 8; CL = CL(IDD); AL = tRCD(IDD) - 1*tCK(IDD); tCK= tCK(IDD); tRC= tRC(IDD); tRRD = tRRD(IDD); tRCD = 1*tCK(IDD); CKE is HIGH; CS# is HIGH between valid commands; Address bus inputs are STABLE during DESELECTs; Data pattern is same as IDD4R.	IDD7*	3790	3160	mA
Notes: IDD specification is based on Samsung A-die components. *: Value calculated as one module rank in this operating condition, and all other module ranks in IDD2P (CKE LOW) mode. **: Value calculated reflects all module ranks in this operating condition.				



Product Specifications

PART NO.:

VL33B2K60A-K9/F8S

REV: 1.0

AC TIMING PARAMETERS & SPECIFICATIONS

Parameter	Symbol	K9 (DDR3-1333)		F8 (DDR3-1066)		Unit
		MIN	MAX	MIN	MAX	
Clock Timing						
Minimum Clock Cycle Time (DLL off mode)	tCK(DLL_OFF)	8	-	8	-	ns
Average Clock Period	tCK(avg)	1.5	<1.875	1.875	<2.5	ns
Clock Period	tCK(abs)	tCK(avg)min + tJIT(per)min	tCK(avg)max + tJIT(per)max	tCK(avg)min + tJIT(per)min	tCK(avg)max + tJIT(per)max	ns
Average high pulse width	tCH(avg)	0.47	0.53	0.47	0.53	tCK(avg)
Average low pulse width	tCL(avg)	0.47	0.53	0.47	0.53	tCK(avg)
Clock Period Jitter	tJIT(per)	-80	80	-90	90	ps
Clock Period Jitter during DLL locking period	tJIT(per, lck)	-70	70	-80	80	ps
Cycle to Cycle Period Jitter	tJIT(cc)	160		180		ps
Cycle to Cycle Period Jitter during DLL locking period	tJIT(cc, lck)	140		160		ps
Cumulative error across 2 cycles	tERR(2per)	-118	118	-132	132	ps
Cumulative error across 3 cycles	tERR(3per)	-140	140	-157	157	ps
Cumulative error across 4 cycles	tERR(4per)	-155	155	-175	175	ps
Cumulative error across 5 cycles	tERR(5per)	-168	168	-188	188	ps
Cumulative error across 6 cycles	tERR(6per)	-177	177	-200	200	ps
Cumulative error across 7 cycles	tERR(7per)	-186	186	-209	209	ps
Cumulative error across 8 cycles	tERR(8per)	-193	193	-217	217	ps
Cumulative error across 9 cycles	tERR(9per)	-200	200	-224	224	ps
Cumulative error across 10 cycles	tERR(10per)	-205	205	-231	231	ps
Cumulative error across 11 cycles	tERR(11per)	-210	210	-237	237	ps
Cumulative error across 12 cycles	tERR(12per)	-215	215	-242	242	ps
Cumulative error across n = 13, 14 ... 49, 50 cycles	tERR(nper)	$tERR(nper)min = (1 + 0.68ln(n)) * tJIT(per)min$ $tERR(nper)max = (1 + 0.68ln(n)) * tJIT(per)max$				ps
Absolute clock HIGH pulse width	tCH(abs)	0.43	-	0.43	-	tCK(avg)
Absolute clock Low pulse width	tCL(abs)	0.43	-	0.43	-	tCK(avg)
Data Timing						
DQS, DQS# to DQ skew, per group, per access	tDQSQ	-	125	-	150	ps
DQ output hold time from DQS, DQS#	tQH	0.38	-	0.38	-	tCK(avg)
DQ low-impedance time from CK, CK#	tLZ(DQ)	-500	250	-600	300	ps
DQ high-impedance time from CK, CK#	tHZ(DQ)	-	250	-	300	ps
Data setup time to DQS, DQS# referenced to Vih(ac)Vil(ac) levels	tDS(base)	30	-	25	-	ps
Data hold time to DQS, DQS# referenced to Vih(ac)Vil(ac) levels	tDH(base)	65	-	100	-	ps
DQ and DM Input pulse width for each input	tDIPW	400	-	490	-	ps



Product Specifications

PART NO.:

VL33B2K60A-K9/F8S

REV: 1.0

AC TIMING PARAMETERS & SPECIFICATIONS

Parameter	Symbol	K9 (DDR3-1333)		F8 (DDR3-1066)		Unit	
		MIN	MAX	MIN	MAX		
Data Strobe Timing							
DQS, DQS# READ Preamble	tRPRE	0.9	-	0.9	-	tCK	
DQS, DQS# differential READ Postamble	tRPST	0.3	-	0.3	-	tCK	
DQS, DQS# output high time	tQSH	0.4	-	0.38	-	tCK(avg)	
DQS, DQS# output low time	tQSL	0.4	-	0.38	-	tCK(avg)	
DQS, DQS# WRITE Preamble	tWPRE	0.9	-	0.9	-	tCK	
DQS, DQS# WRITE Postamble	tWPST	0.3	-	0.3	-	tCK	
DQS, DQS# rising edge output access time from rising CK, CK#	tDQSK	-255	255	-300	300	ps	
DQS, DQS# low-impedance time (Referenced from RL-1)	tLZ(DQS)	-500	250	-600	300	ps	
DQS, DQS# high-impedance time (Referenced from RL+BL/ 2)	tHZ(DQS)	-	250	-	300	ps	
DQS, DQS# differential input low pulse width	tDQSL	0.45	0.55	0.45	0.55	tCK	
DQS, DQS# differential input high pulse width	tDQSH	0.45	0.55	0.45	0.55	tCK	
DQS, DQS# rising edge to CK, CK# rising edge	tDQSS	-0.25	0.25	-0.25	0.25	tCK(avg)	
DQS, DQS# failing edge setup time to CK, CK# rising edge	tDSS	0.2	-	0.2	-	tCK(avg)	
DQS, DQS# failing edge hold time to CK, CK# rising edge	tDSH	0.2	-	0.2	-	tCK(avg)	
Command and Address Timing							
DLL locking time	tDLLK	512	-	512	-	nCK	
Internal READ Command to PRECHARGE Command delay	tRTP	max (4tCK, 7.5ns)	-	max (4tCK, 7.5ns)	-		
Delay from start of internal write transaction to internal read command	tWTR	max (4tCK, 7.5ns)	-	max (4tCK, 7.5ns)	-		
WRITE recovery time	tWR	15	-	15	-	ns	
Mode Register Set command cycle time	tMRD	4	-	4	-	nCK	
Mode Register Set command update delay	tMOD	max (12tCK, 15ns)	-	max (12tCK, 15ns)	-		
CAS# to CAS# command delay	tCCD	4	-	4	-	nCK	
Auto precharge write recovery + precharge time	tDAL(min)	WR + roundup (tRP / tCK(AVG))					nCK
Multi-Purpose Register Recovery Time	tMPRR	1	-	1	-	nCK	
ACTIVE to PRECHARGE command period	tRAS	36	9*tREFI	37.5	9*tREFI	ns	
ACTIVE to ACTIVE command period for 1KB page size	tRRD	max (4tCK, 6ns)	-	max (4tCK, 7.5ns)	-		
ACTIVE to ACTIVE command period for 2KB page size	tRRD	max (4tCK, 7.5ns)	-	max (4tCK, 10ns)	-		
Four activate window for 1KB page size	tFAW	30	-	37.5	-	ns	
Four activate window for 2KB page size	tFAW	45	-	50	-	ns	
Command and Address setup time to CK, CK# referenced to Vih(ac) / Vil(ac) levels	tIS(base)	65	-	125	-	ps	
Command and Address hold time from CK, CK# referenced to Vih(ac) / Vil(ac) levels	tIH(base)	140	-	200	-	ps	
Control & Address Input pulse width for each input	tIPW	620	-	780	-	ps	

Product Specifications

PART NO.:

VL33B2K60A-K9/F8S

REV: 1.0

AC TIMING PARAMETERS & SPECIFICATIONS

Parameter	Symbol	K9 (DDR3-1333)		F8 (DDR3-1066)		Unit
		MIN	MAX	MIN	MAX	
Refresh Timing						
4Gb REFRESH to REFRESH OR REFRESH to ACTIVE command interval	tRFC	300	-	300	-	ns
Average periodic refresh interval (0°C ≤ TCASE ≤ 85 °C)	tREFI	7.8	-	7.8	-	us
Average periodic refresh interval (85°C ≤ TCASE ≤ 95 °C)	tREFI	3.9	-	3.9	-	us
Calibration Timing						
Power-up and RESET calibration time	tZQinitl	512	-	512	-	tCK
Normal operation Full calibration time	tZQoper	256	-	256	-	tCK
Normal operation Short calibration time	tZQCS	64	-	64	-	tCK
Reset Timing						
Exit Reset from CKE HIGH to a valid command	tXPR	max(5tCK, tRFC + 10ns)	-	max(5tCK, tRFC + 10ns)	-	
Self Refresh Timing						
Exit Self Refresh to commands not requiring a locked DLL	tXS	max(5tCK, tRFC + 10ns)	-	max(5tCK, tRFC + 10ns)	-	
Exit Self Refresh to commands requiring a locked DLL	tXSDLL	tDLLK(min)	-	tDLLK(min)	-	nCK
Minimum CKE low width for Self refresh entry to exit timing	tCKESR	tCKE(min) + 1tCK	-	tCKE(min) + 1tCK	-	
Valid Clock Requirement after Self Refresh Entry (SRE)	tCKSRE	max(5tCK, 10ns)	-	max(5tCK, 10ns)	-	
Valid Clock Requirement before Self Refresh Exit (SRX)	tCKSRX	max(5tCK, 10ns)	-	max(5tCK, 10ns)	-	
Power Down Timing						
Exit Power Down with DLL to any valid command; Exit Precharge Power Down with DLL frozen to commands not requiring a locked DLL	tXP	max(3tCK, 6ns)	-	max(3tCK, 7.5ns)	-	
Exit Precharge Power Down with DLL frozen to commands requiring a locked DLL	tXPDLL	max(10tCK, 24ns)	-	max(10tCK, 24ns)	-	
CKE minimum pulse width	tCKE	max(3tCK, 5.625ns)	-	max(3tCK, 5.625ns)	-	
Command pass disable delay	tCPDED	1	-	1	-	nCK
Power Down Entry to Exit Timing	tPD	tCKE(min)	9*tREFI	tCKE(min)	9*tREFI	tCK
Timing of ACT command to Power Down entry	tACTPDEN	1	-	1	-	nCK
Timing of PRE command to Power Down entry	tPRPDEN	1	-	1	-	nCK
Timing of RD/RDA command to Power Down entry	tRDPDEN	RL + 4 + 1	-	RL + 4 + 1	-	
Timing of WR command to Power Down entry BL8 (OTF, MRS), BL4OTF	tWRPDEN	WL + 4 + (tWR/tCK)	-	WL + 4 + (tWR/tCK)	-	nCK
Timing of WRA command to Power Down entry BL8 (OTF, MRS), BL4OTF	tWRAPDEN	WL+4+WR+1	-	WL+4+WR+1	-	nCK
Timing of WR command to Power Down entry (BL4MRS)	tWRPDEN	WL + 2 + (tWR/tCK)	-	WL + 2 + (tWR/tCK)	-	nCK
Timing of WRA command to Power Down entry (BL4MRS)	tWRAPDEN	WL+2+WR+1	-	WL+2+WR+1	-	nCK
Timing of REF command to Power Down entry	tREFPDEN	1	-	1	-	
Timing of MRS command to Power Down entry	tMRSPDEN	tMOD(min)	-	tMOD(min)	-	



Product Specifications		
PART NO.:	VL33B2K60A-K9/F8S	REV: 1.0

AC TIMING PARAMETERS & SPECIFICATIONS						
Parameter	Symbol	K9 (DDR3-1333)		F8 (DDR3-1066)		Unit
		MIN	MAX	MIN	MAX	
ODT Timing						
ODT high time without write command or with write command and BC4	ODTH4	4	-	4	-	nCK
ODT high time with Write command and BL8	ODTH8	6	-	6	-	nCK
Asynchronous RTT turn-on delay (Power-Down with DLL frozen)	tAONPD	2	8.5	2	8.5	ns
Asynchronous RTT turn-off delay (Power-Down with DLL frozen)	tAOFPD	2	8.5	2	8.5	ns
ODT turn-on	tAON	-250	250	-300	300	ps
RTT_NOM and RTT_WR turn-off time from ODTL off reference	tAOF	0.3	0.7	0.3	0.7	tCK(avg)
RTT dynamic change skew	tADC	0.3	0.7	0.3	0.7	tCK(avg)
Write Leveling Timing						
First DQS pulse rising edge after tDQSS margining mode is programmed	tWLMRD	40	-	40	-	tCK
DQS/DQS delay after tDQS margining mode is programmed	tWLDQSEN	25	-	25	-	tCK
Setup time for tDQSS latch	tWLS	195	-	245	-	ps
Hold time for tDQSS latch	tWLH	195	-	245	-	ps
Write leveling output delay	tWLO	0	9	0	9	ns
Write leveling output error	tWLOE	0	2	0	2	ns

Product Specifications		
PART NO.:	VL33B2K60A-K9/F8S	REV: 1.0

Package Dimensions

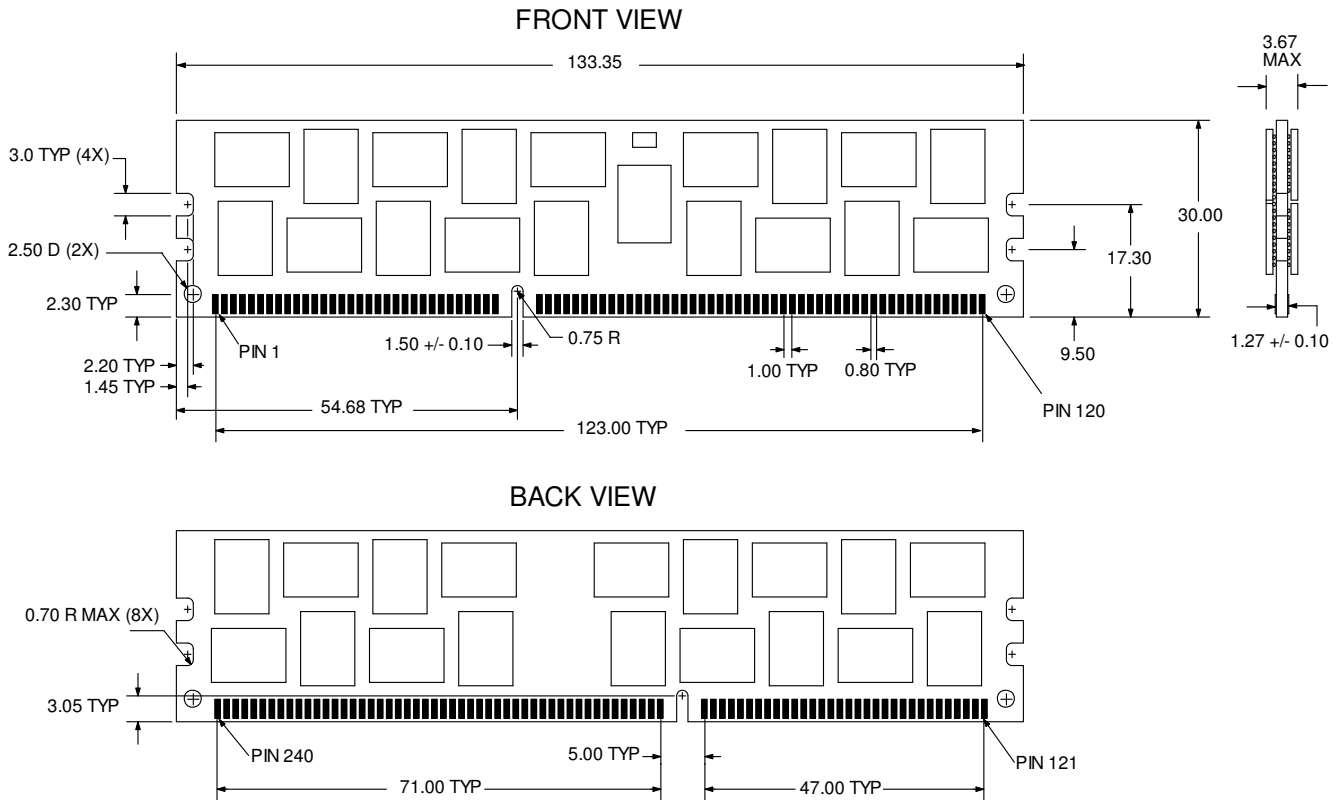

Note: 1. All dimensions are in millimeters with tolerance +/- 0.15mm unless otherwise specified.
 2. The dimensional diagram is for reference only.



Product Specifications		
PART NO.:	VL33B2K60A-K9/F8S	REV: 1.0

Revision History:

Date	Rev.	Page	Changes
02/23/2011	1.0	All	Spec release