



(Low Distortion) 1 Hz to 102.4 kHz  
8 or 9-Bit Frequency Selectable

Oscillators: Dual Channel  
& Quadrature

**Description**

The SPPOSC Series is a compact, dual channel, phase continuous, DSP based, programmable sine wave generator with analog outputs and 8 or 9 bits of frequency selection. All SPPOSC-01 platforms are small, low profile, easy to use signal generators, which require no external components and can cover the audio/ultrasonic bandwidth from 1 Hz to 102.4 kHz in several standard and custom frequency ranges. SPPOSC's use a fixed point DSP with 32-bit math, 24-bits of resolution and dual channel DACs. Noise floor and distortion are typically -100dB to 20 kHz and < -80 dB to 100 kHz.

**Features/ Benefits:**

- Available in a single, dual or quadrature (0.1° phase stability) form factor, SPPOSC oscillators with up to 512 tuning steps insure design flexibility in a compact 2" x 2" footprint while minimizing board space requirements.
- This plug-in, turnkey signal source, with a standard or custom algorithm, allows product designers to incorporate various precision on-board programmable signal generators in a standard pin-out and form factor thereby reducing design time while maximizing design flexibility.
- When used in conjunction with the SPPDB-01 development board, SPPOCS signal generators require minimal set-up time to provide low noise and distortion signals for laboratory evaluation or precision field installations.

**Applications**

- Low distortion signal source for ATE systems
- Sound and vibration testing
- Quadrature signal generator: sine / cosine, standard or custom.
- Tone generation in speech and hearing analysis, research, pathology

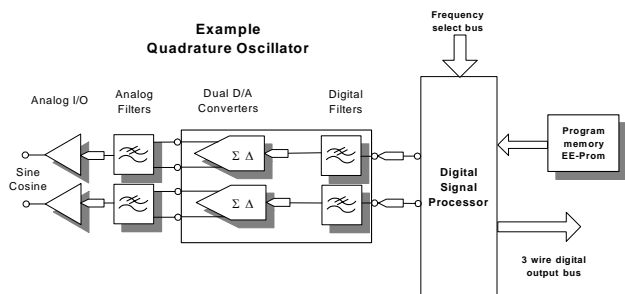

**OSCILLATOR SOFTWARE SELECTION GUIDE**

SPPOSC-01	Low Frequency Ranges
SWDO-01	Dual Chl. Prog. Osc. 1 Hz - 256 Hz, 1 Hz Steps
SWDO-02	Dual Chl. Prog. Osc. 10 Hz - 2.56 kHz, 10 Hz Steps
SWQO-01	Quadrature Prog. Osc. 1 Hz - 512 Hz, 1 Hz Steps
SWQO-02	Quadrature Prog. Osc. 10 Hz - 5.12 kHz, 10 Hz Steps
SWSO-01	Same Prog. Dual Chl. Osc. 1 Hz - 512 Hz, 1 Hz Steps
SWSO-02	Same Prog. Dual Chl. Osc. 10 Hz - 5.12 kHz, 10 Hz Steps
SPPOSC-02	High Frequency Ranges
SWDO-03	Dual Chl. Prog. Osc. 100 Hz - 25.6 kHz, 100 Hz Steps
SWDO-04	Dual Chl. Prog. Osc. 200 Hz - 51.2 kHz, 200 Hz Steps
SWDO-05	Dual Chl. Prog. Osc. 400 Hz - 102.4 kHz, 400 Hz Steps
SWQO-03	Quadrature Prog. Osc. 100 Hz - 51.2 kHz, 100 Hz Steps
SWQO-04	Quadrature Prog. Osc. 200 Hz - 102.4 kHz, 200 Hz Steps
SWSO-03	Same Prog. Dual Chl. Osc. 100 Hz - 51.2 kHz, 100 Hz Steps
SWSO-04	Same Prog. Dual Chl. Osc. 200 Hz - 102.4 kHz, 200 Hz Steps
CUSTOM SW	Custom Frequency Ranges
SWDO-CXX	Custom Dual Chl. Prog. Oscillator
SWQO-CXX	Custom Quadrature Prog. Oscillator
SWSO-CXX	Custom Same Prog. Dual Chl. Oscillator



(Low Distortion) 1 Hz to 102.4 kHz  
8 or 9-Bit Frequency Selectable

Oscillators: Dual Channel  
& Quadrature

Frequency Selection Data Port

Data Format

- Logic "0"                    0VDC Min – 2VDC Max
- Logic "1"                    3.5VDC Min – 5Vdc Max

Bit Weighting (Binary Coded)

D<sub>0</sub>                                LSB

D<sub>7</sub> or D<sub>8</sub> (for 9-bits)        MSB

Frequency: 256:1 (8-bit dual),  
or 512:1 (9-bit single)

1. The frequency selection data word bus consists of D<sub>0</sub> to D<sub>7</sub> for 8-bit programming and D<sub>0</sub> to D<sub>8</sub> for 9-bit programming.
2. For dual Channel 8-Bit programming D<sub>8</sub> is Channel Select and requires a minimum of 21 μsecs set-up time at a logic "1", 5volts for channel 2 or logic "0", 0 volts, for Channel 1
3. For an 8-bit dual channel unit, the Program enable or "Latch pin" is D<sub>9</sub>. To enable a program change, this pin must be pulled to a logic high "1" or 5 volts. If the pin is low, a frequency change will not be read and the channels will continue to run the previous values.
4. The D<sub>0</sub> – D<sub>9</sub> bus data are checked simultaneously. New frequency selection data must be present or updated at the time Channel select occurs to be valid. The Program enable or "Latch" pin must be high. While the latch pin is high, the Frequency data must remain on the bus until the user applies the next frequency change. The pins do not float during programming! The frequency ports are polled by the system every 21 μseconds. Within 21 μsecs of programming, if the latch goes low, the programmed values are retained and the pins may float.

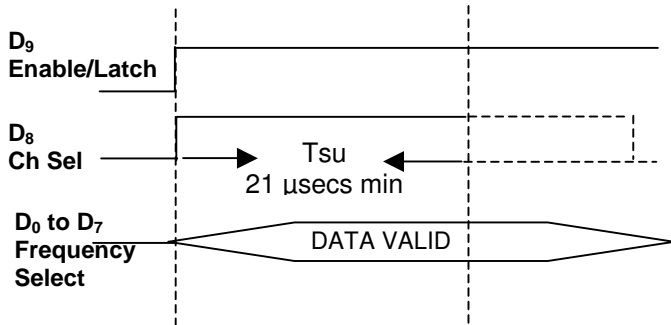

9-Bit Programming Table

MSB	---	---	---	---	---	---	---	LSB	Bit Weight
2 <sup>8</sup> D <sub>8</sub>	2 <sup>7</sup> D <sub>7</sub>	2 <sup>6</sup> D <sub>6</sub>	2 <sup>5</sup> D <sub>5</sub>	2 <sup>4</sup> D <sub>4</sub>	2 <sup>3</sup> D <sub>3</sub>	2 <sup>2</sup> D <sub>2</sub>	2 <sup>1</sup> D <sub>1</sub>	2 <sup>0</sup> D <sub>0</sub>	f <sub>c</sub> Corner Frequency
0	0	0	0	0	0	0	0	0	f <sub>max</sub> /512
0	0	0	0	0	0	0	0	1	f <sub>max</sub> /256
0	0	0	0	0	0	0	1	1	f <sub>max</sub> /128
0	0	0	0	0	0	1	1	1	f <sub>max</sub> /64
0	0	0	0	0	1	1	1	1	f <sub>max</sub> /32
0	0	0	0	1	1	1	1	1	f <sub>max</sub> /16
0	0	0	1	1	1	1	1	1	f <sub>max</sub> /8
0	0	1	1	1	1	1	1	1	f <sub>max</sub> /4
0	1	1	1	1	1	1	1	1	f <sub>max</sub> /2
1	1	1	1	1	1	1	1	1	f <sub>max</sub>

8-Bit Programming Table

MSB	---	---	---	---	---	---	LSB	Bit Weight
2 <sup>7</sup> D <sub>7</sub>	2 <sup>6</sup> D <sub>6</sub>	2 <sup>5</sup> D <sub>5</sub>	2 <sup>4</sup> D <sub>4</sub>	2 <sup>3</sup> D <sub>3</sub>	2 <sup>2</sup> D <sub>2</sub>	2 <sup>1</sup> D <sub>1</sub>	2 <sup>0</sup> D <sub>0</sub>	f <sub>c</sub> Corner Frequency
0	0	0	0	0	0	0	0	f <sub>max</sub> /256
0	0	0	0	0	0	0	1	f <sub>max</sub> /128
0	0	0	0	0	0	1	1	f <sub>max</sub> /64
0	0	0	0	0	1	1	1	f <sub>max</sub> /32
0	0	0	0	1	1	1	1	f <sub>max</sub> /16
0	0	0	1	1	1	1	1	f <sub>max</sub> /8
0	0	1	1	1	1	1	1	f <sub>max</sub> /4
0	1	1	1	1	1	1	1	f <sub>max</sub> /2
1	1	1	1	1	1	1	1	f <sub>max</sub>



(Low Distortion) 1 Hz to 102.4 kHz  
8 or 9-Bit Frequency Selectable

Oscillators: Dual Channel  
& Quadrature

<b>SPPOSC-01 &amp; 02</b>	
<b>Performance Specifications</b>	
Available Tuning Range	1.00 Hz to 102.4 kHz
Frequency Accuracy	< ± 0.05 %
Amplitude Accuracy	< ± 0.1 dB
Total Broad Band Noise (Ref to 3.53 VRMS)	< -100dB Max., -105dB Typ.
Total Harm. Dist.(THD) (10V peak to peak)	<-100 dB Max. to 20 kHz < - 80 dB Max. to 102.4 kHz
Channel to Channel phase tracking	< ± 0.10°
(SWDO-01 to 05) Cross talk dual channel version with different frequencies on each channel.	1 Hz -10K < - 100 dB Typ. 10kH - 100K < - 90 dB Typ.

There are three software configurations available for these **SPPOSC-01 / -02** oscillators.

Software Options:

1. **SWDO-01 to -05:** Dual channel with independently selectable frequencies.
2. **SWSO-01 to -04:** Dual Channel, same output and same frequency selection.
3. **SWQO-01 to -04:** Quadrature, single frequency selection and Sine/Cosine outputs.

All configurations are available with custom frequency selections. Consult factory for a quotation.

These special programs will be assigned a custom suffix (CXX) at the time of order.

### Specifications

(@25°C and Vs = ±15 Vdc)

#### Analog Output Characteristics

Minimum load Impedance	10 kΩ
Maximum capacitive load	50 pF.
Output voltage	± 5 V peak (sine wave)
Offset Voltage	2 mV Typ. 10mV Max.

#### Power Supply (±Vs)

Analog Vs range	±10Vdc Min to ±15 Vdc Max.
Analog supply current at Max. Vs	17 mA Typ.
Digital PS Voltage	+5 Vdc
Digital supply current	150 mA Typ.
Power consumption at Max. Vs	1.5 watts Max.

**Care must be taken to stay above the minimum Vs in order to maintain the linearity and distortion performance of the oscillator.**

#### Temperature

Operating	0 to +70°C
Storage	-25 to +85°C

**Size** 2.0" x 2.0" x 0.5"

A socketed development board (**SPPDB-01**) can double as an oscillator mounting assembly, to facilitate product evaluation or laboratory use.

The **SPPDB-01** development board is specified and sold separately.



(Low Distortion) 1 Hz to 102.4 kHz  
8 or 9-Bit Frequency Selectable

Oscillators: Dual Channel  
& Quadrature

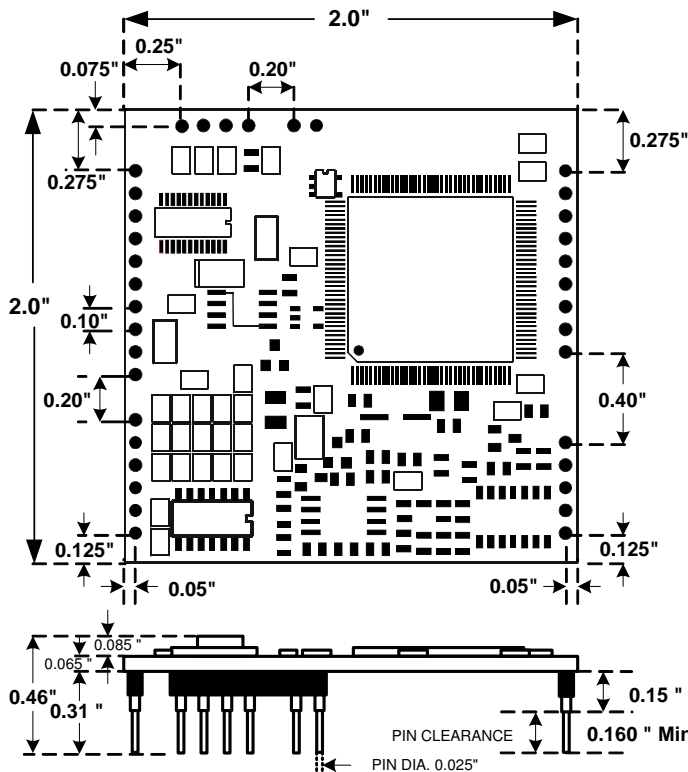

**SPPOSC TOP VIEW  
AND DIMENSIONS**  
All normal pin spacing 0.10"

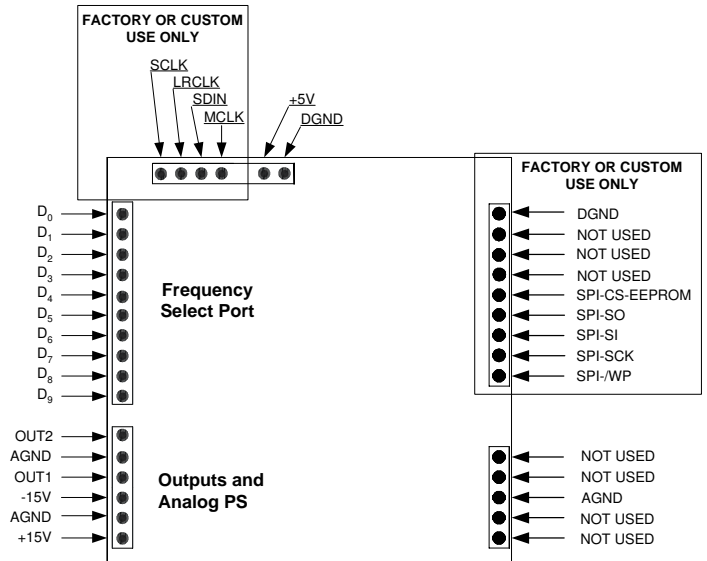

**SPPOSC TOP VIEW  
PIN IDENTIFICATION**

- D<sub>0</sub> – D<sub>7</sub> or 8 8 or 9 – bit Frequency select pins
- D<sub>8</sub> Channel select for 8 bit dual Osc.
- D<sub>9</sub> Enable / Latch for 8 bit dual Osc.
- Out 1 & 2 Oscillator outputs
- ± 15 Vdc Analog Dc power In
- + 5 Vdc Digital Power In
- A Gnd Analog Ground
- D Gnd Digital Ground

**ORDERING INFORMATION**

SPPOSC - 01 / SWQO - 01

01 Low Freq. range  
02 High Freq. range

Selectable Frequency range  
example -01 (1 Hz to 512 Hz)  
See Selection guide front page.

Oscillator Software type  
example SWQO (Quadrature)  
SWDO Dual channel  
SWSO Same freq dual

Consult factory for custom non-standard frequencies and ranges.  
The SPPDB – 01 Mounting Assembly is available for this Oscillator.

We hope the information given here will be helpful. The information is based on data and our best knowledge, and we consider the information to be true and accurate. Please read all statements, recommendations or suggestions herein in conjunction with our conditions of sale which apply to all goods supplied by us. We assume no responsibility for the use of these statements, recommendations or suggestions, nor do we intend them as a recommendation for any use which would infringe any patent or copyright.