

**100 Hz to 100 kHz
Band Pass Filter**

**Fixed Frequency
4-Pole Pair Band Pass Filters**

Description:

The D68HPLP Series of small 4-pole-pair fixed frequency, precision band-pass active filters provide high performance in a compact 32-pin DIP package, with a broad range of fixed center frequencies (f_0) from 1 Hz to 100 kHz. Each filter type features a near theoretical amplitude/phase response along with low output voltage noise enabling these filters to achieve a 10,000:1 or better dynamic signal range.

These filters consist of a four pole Butterworth high pass filter followed by a four pole Bessel or Butterworth low pass filter in one package. The user can select the low pass and high pass filter cutoff frequencies as long as they are not too close to each other. The Q of this filter must remain below 1. For Qs of higher than 1 see our D68BP series of filters. See note 1 below to determine how to calculate the filter Q.

Both frequencies are factory pre-tuned to within $\pm 2\%$ of the fixed, user specified high pass and low pass frequencies. Band pass D68HPLP filters pass all frequencies lying between the upper and lower -3dB points of the amplitude response curve.

Features/Benefits:

- Small 32-pin DIP (1.8"L x 0.8"W) footprint minimizes board space requirements.
- Plug-in ready-to-use, reducing engineering design and manufacturing cycle time.
- Factory tuned, no external clocks or adjustments needed
- Broad range of corner frequencies to meet a wide range of applications.

Applications

- Transducer output filtering:
- Production test instrumentation
- Medical electronics equipment and research
- Noise and harmonic analysis
- Frequency spectrum analysis



Available Band-Pass Models:	Page
D68HPLP 4-Pole Pair	2
General Specifications	
Pin-out/package data & order information	3



100 Hz to 100 kHz
Band Pass Filter

Fixed Frequency
4-Pole Pair Band Pass Filters

D68HPLP	
Product Specifications	
	Band-Pass
Size	1.8" x 0.8" x 0.3"
Range f_o	1 Hz to 100 kHz
RAvailable "Q's" ¹	<1
High Pass Theoretical Transfer Characteristics	Appendix A Page 31
Low Pass Theoretical Transfer Characteristics Butterworth	Appendix A Page 11
Low Pass Theoretical Transfer Characteristics Bessel	Appendix A Page 5
Pass-Band Gain (non-inverting)	0 ± 0.2 dB typ. 0 ± 0.4 dB max.
Attenuation Rate	24 dB/octave
Both Center Frequency	f_o ± 2% max.
Stability	± 0.01%/°C
Filter Mounting Assembly ²	FMA-01S

1. Quality factor for this filter is: $Q = \frac{f_o}{\Delta f}$ The center frequency of this filter is: $f_o = \sqrt{f_h \times f_l}$ All Q's must be less than 1. For Q's of more than one see our D64BP and D68BP series of filters.

Specifications
(25°C and $V_s \pm 15$ Vdc)

Pin-Out and Package Data
Ordering Information

Analog Input Characteristics¹

Impedance 10.0 k Ω min.
Voltage Range ± 10 V_{peak}
Max. Safe Voltage $\pm V_s$

Analog Output Characteristics

Impedance 1 Ω typ.,
10 Ω max..
Linear Operating Range ± 10 V
Current² @ (V_s @ ± 15 V) 2 mA max.
Offset Voltage³ 2 mV typ.
20 mV max.
Offset Temp. Coefficient 50 μ V/°C.

Power Supply ($\pm V_s$)

Rated Voltage ± 15 V
Operating Range ± 5 V min.
 ± 18 V max.
Quiescent Current 25 mA typ.
40 mA max.

Temperature Range

Operating 0°C to +70°C
Storage -25°C to +85°C

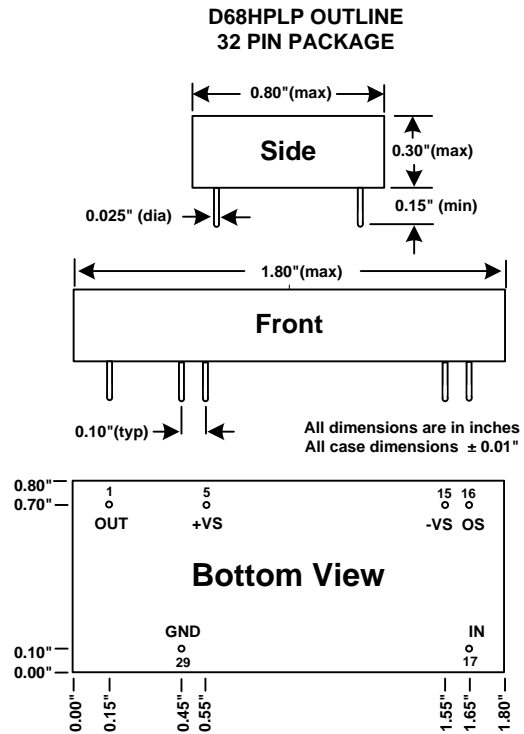

DC Offset Adjustment

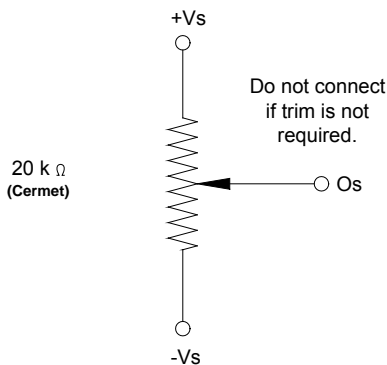

Notes:

- Input and output signal voltage referenced to supply common.
- Output is short circuit protected to common. DO NOT CONNECT TO $\pm V_s$.
- Adjustable to zero.
- Units operate with or without offset pin connected.
- How to specify Corner Frequency. Corner frequency is specified by attaching two three-digit frequency designators to the basic model number. The first number is the high pass corner frequency and the second number is the low pass corner frequency.

ORDERING INFORMATION

D68HPLP-10.0 Hz-10.0 kHz

High Pass Corner Freq ⁵	Low Pass Corner Freq ⁵
e.g., 849 Hz	e.g., 849 Hz
2.50 kHz	2.50 kHz
33.3 kHz	33.3 kHz

Note: To order the Bessel Low-Pass filter use part number D68HPLPL

We hope the information given here will be helpful. The information is based on data and our best knowledge, and we consider the information to be true and accurate. Please read all statements, recommendations or suggestions herein in conjunction with our conditions of sale, which apply, to all goods supplied by us. We assume no responsibility for the use of these statements, recommendations or suggestions, nor do we intend them as a recommendation for any use, which would infringe any patent or copyright.



High-Pass 4-Pole Butterworth

Appendix A

Theoretical Transfer Characteristics

f/fc (Hz)	Amp (dB)	Phase (deg)	Delay ¹ (sec)
0.10	-80.0	345	.418
0.20	-55.9	330	.423
0.30	-41.8	314	.433
0.40	-31.8	299	.449
0.50	-24.1	282	.474
0.60	-17.8	264	.511
0.70	-12.6	245	.558
0.80	-8.43	224	.604
0.85	-6.69	213	.619
0.90	-5.22	202	.622
0.95	-3.99	191	.612
1.00	-3.01	180	.588
1.20	-0.908	143	.427
1.40	-0.285	118	.289
1.60	-0.100	100	.204
1.80	-0.039	87.6	.152
2.00	-0.017	78.0	.119
2.50	-0.003	61.4	.072
3.00	-0.001	50.7	.049
4.00	0.00	37.8	.027
5.00	0.00	30.1	.017
6.00	0.00	25.1	.012
7.00	0.00	21.4	.009
8.00	0.00	18.8	.007
9.00	0.00	16.7	.005
10.0	0.00	15.0	.004

Frequency Response

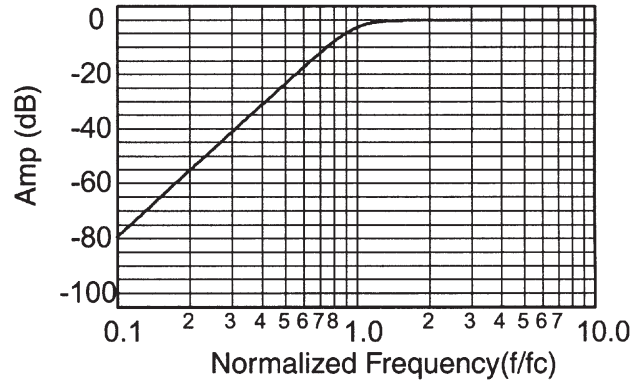

1. Normalized Group Delay:

The above delay data is normalized to a corner frequency of 1.0Hz. The actual delay is the normalized delay divided by the actual corner frequency (fc).

$$\text{Actual Delay} = \frac{\text{Normalized Delay}}{\text{Actual Corner Frequency (fc) in Hz}}$$



Low-Pass 4-Pole Butterworth

Appendix A

Theoretical Transfer Characteristics

f/fc (Hz)	Amp (dB)	Phase (deg)	Delay ¹ (sec)
0.00	0.00	0.00	.416
0.10	0.00	-15.0	.418
0.20	0.00	-30.1	.423
0.30	-0.00	-45.5	.433
0.40	-0.003	-61.4	.449
0.50	-0.017	-78.0	.474
0.60	-0.072	-95.7	.511
0.70	-0.243	-115	.558
0.80	-0.674	-136	.604
0.85	-1.047	-147	.619
0.90	-1.555	-158	.622
0.95	-2.21	-169	.612
1.00	-3.01	-180	.588
1.10	-4.97	-200	.513
1.20	-7.24	-217	.427
1.30	-9.62	-231	.350
1.40	-12.0	-242	.289
1.50	-14.3	-252	.241
1.60	-16.4	-260	.204
1.70	-18.5	-266	.175
1.80	-20.5	-272	.152
1.90	-22.3	-277	.134
2.00	-24.1	-282	.119
2.25	-28.2	-291	.091
2.50	-31.8	-299	.072
2.75	-35.1	-304	.059
3.00	-38.2	-309	.049
3.25	-41.0	-313	.041
3.50	-43.5	-317	.035
4.00	-48.2	-322	.027
5.00	-55.9	-330	.017
6.00	-62.3	-335	.012
7.00	-67.6	-339	.009
8.00	-72.2	-341	.007
9.00	-76.3	-343	.005
10.0	-80.0	-345	.004

Frequency Response

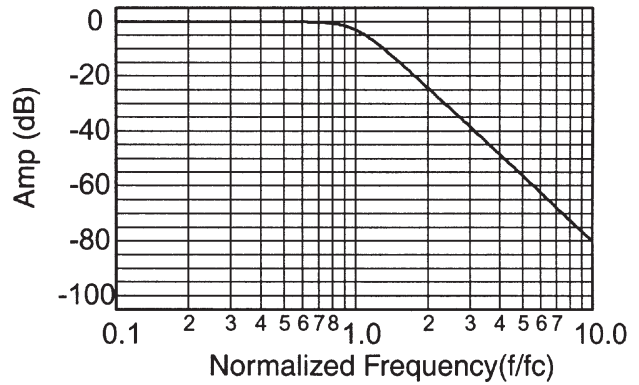

Delay (Normalized)

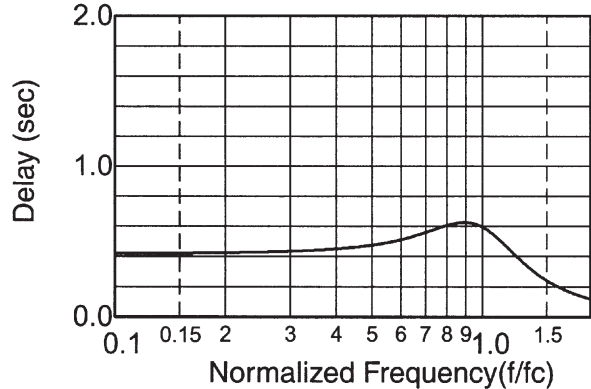

Step Response

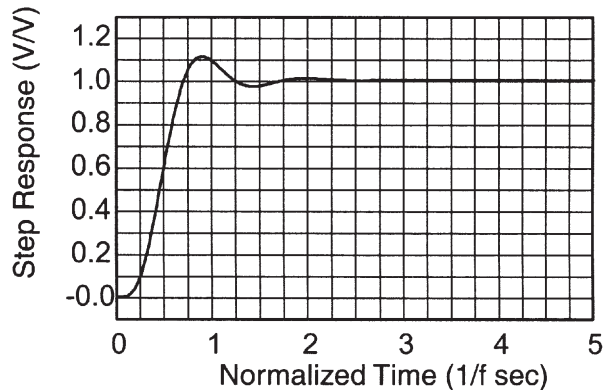

1. Normalized Group Delay:

The above delay data is normalized to a corner frequency of 1.0Hz. The actual delay is the normalized delay divided by the actual corner frequency (fc).

$$\text{Actual Delay} = \frac{\text{Normalized Delay}}{\text{Actual Corner Frequency (fc) in Hz}}$$



Low-Pass 4-Pole Bessel

Appendix A

Theoretical Transfer Characteristics

f/fc (Hz)	Amp (dB)	Phase (deg)	Delay ¹ (sec)
0.00	0.00	0.00	.336
0.10	-0.028	-12.1	.336
0.20	-0.111	-24.2	.336
0.30	-0.251	-36.3	.336
0.40	-0.448	-48.4	.336
0.50	-0.705	-60.6	.336
0.60	-1.02	-72.7	.336
0.70	-1.41	-84.8	.336
0.80	-1.86	-96.8	.335
0.85	-2.11	-103	.334
0.90	-2.40	-109	.333
0.95	-2.69	-115	.332
1.00	-3.01	-121	.330
1.10	-3.71	-133	.325
1.20	-4.51	-144	.318
1.30	-5.39	-156	.308
1.40	-6.37	-166	.295
1.50	-7.42	-177	.280
1.60	-8.54	-187	.263
1.70	-9.71	-195	.246
1.80	-10.9	-204	.228
1.90	-12.2	-212	.211
2.00	-13.4	-219	.194
2.25	-16.5	-235	.158
2.50	-19.5	-248	.129
2.75	-22.4	-259	.107
3.00	-25.1	-267	.089
3.25	-27.6	-275	.076
3.50	-30.0	-281	.065
4.00	-34.4	-291	.049
5.00	-41.9	-305	.031
6.00	-48.1	-315	.021
7.00	-53.4	-321	.016
8.00	-58.0	-326	.012
9.00	-62.0	-330	.009
10.0	-65.7	-333	.008

Frequency Response

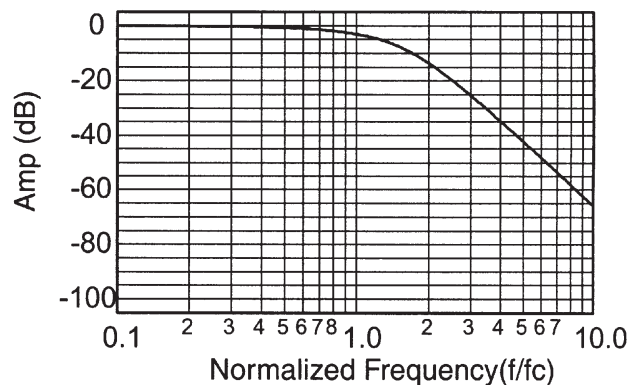

Delay (Normalized)

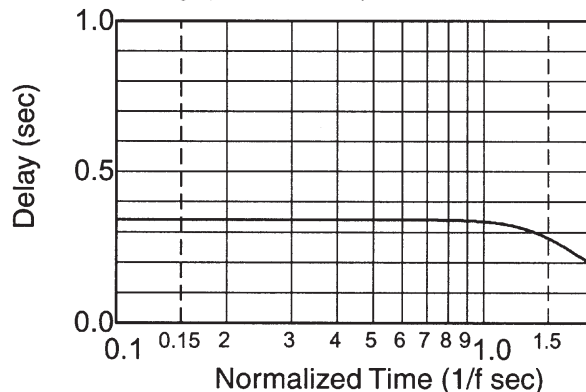

Step Response

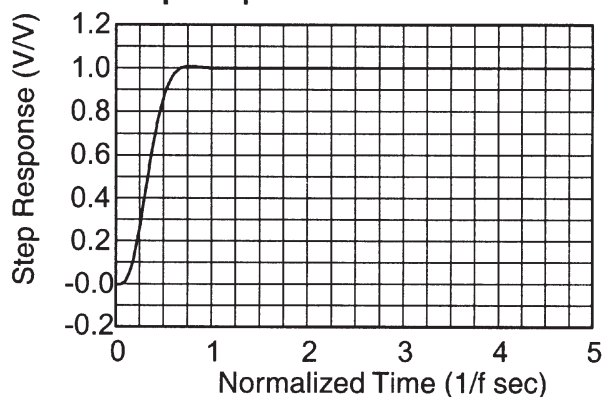

1. Normalized Group Delay:

The above delay data is normalized to a corner frequency of 1.0Hz. The actual delay is the normalized delay divided by the actual corner frequency (fc).

$$\text{Actual Delay} = \frac{\text{Normalized Delay}}{\text{Actual Corner Frequency (fc) in Hz}}$$