

Features

- Operating voltage: 4.5V~5.5V
- ADM algorithm
- Low noise
 - Echo mode: -85dB
 - Surround mode: -90dB
- Low distortion rate
 - Echo mode: 1%
 - Surround mode: 0.2%
- Built-in 40Kb SRAM
- Automatic reset function
- 16-pin DIP/SOP package

Applications

- Television
- Karaoke systems
- Video disc player
- Sound equipments

General Description

The HT8972 is an echo/surround effect processor. It is designed for various audio systems including karaoke, television, sound equipments, etc. The chip consists of a built-in pre-amplifier, VCO or Voltage Control OSC, 40Kb SRAM, A/D and D/A converters as well as delay time control logic.

Its built-in 40Kb SRAM can generate delay time effect and can control the delay time value through the external VCO resistor.

The VCO circuit can reduce external components and make it easy to adjust the delay time.

Block Diagram

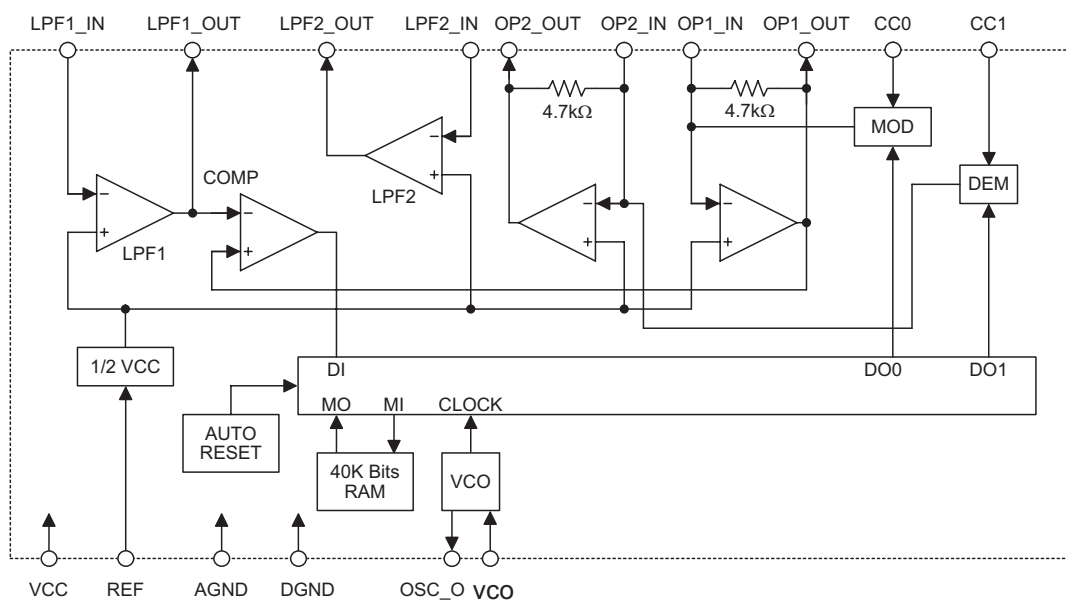

Pad Coordinates

 Unit: μm

Pad No.	X	Y	Pad No.	X	Y
1	-883.875	861.250	9	1027.425	-892.700
2	-865.105	-891.900	10	907.375	890.431
3	-564.105	-892.700	11	715.175	890.429
4	-44.775	-892.700	12	467.375	890.431
5	147.425	-892.700	13	275.175	890.429
6	395.225	-892.700	14	60.790	879.700
7	587.425	-892.700	15	-203.150	868.440
8	835.225	-892.700	16	-783.875	861.250

Pad Description

Pad No.	Pad Name	I/O	Internal Connection	Description
1	DGND	I	—	Digital ground
2	OSC_O	O	—	System oscillator output
3	VCO	I	—	System oscillator input, system frequency adjustable pin
4	CC1	—	—	Current control 1
5	CC0	—	—	Current control 0
6	OP1_OUT	O	—	OP1 output
7	OP1_IN	I	—	OP1 input
8	OP2_IN	I	—	OP2 input
9	OP2_OUT	O	—	OP2 output
10	LPF2_IN	I	—	Low pass filter 2 input
11	LPF2_OUT	O	—	Low pass filter 2 output
12	LPF1_OUT	O	—	Low pass filter 1 output
13	LPF1_IN	I	—	Low pass filter 1 input
14	VCC	I	—	Analog and positive power supply
15	REF	I	—	Analog reference voltage
16	AGND	I	—	Analog ground

Absolute Maximum Ratings

Supply Voltage $V_{SS}-0.3\text{V}$ to $V_{SS}+6.0\text{V}$ Storage Temperature -50°C to 125°C
 Input Voltage $V_{SS}-0.3\text{V}$ to $V_{DD}+0.3\text{V}$ Operating Temperature -20°C to 70°

Note: These are stress ratings only. Stresses exceeding the range specified under "Absolute Maximum Ratings" may cause substantial damage to the device. Functional operation of this device at other conditions beyond those listed in the specification is not implied and prolonged exposure to extreme conditions may affect device reliability.

Electrical Characteristics

Ta=25°C

Symbol	Parameter	Test Conditions		Min.	Typ.	Max.	Unit
		V _{DD}	Conditions				
V _{CC}	Operating Voltage	—	—	4.5	5.0	5.5	V
I _{CC}	Operating Current	5V	—	—	15	30	mA
G _V	Voltage Gain	5V	R _L =47kΩ	—	-0.9	2.5	dB
V _{OMAX}	Maximum Output Voltage	5V	THD=10%	0.9	1.8	—	V _{rms}
THD	Total Harmonic Distortion	5V	Filter= A-Weighting	—	0.7	1.5	%
N _O	Output Noise Voltage	5V	Filter= A-Weighting	—	-85	-60	dBV
PSRR	Power Supply Rejection Ratio	5V	ΔV _{CC} =-20dBV (0.1V _{rms}) f=100Hz	—	-40	-30	dB

Functional Description

The HT8972 is an echo/surround effect generator with built-in 40Kb SRAM. It ensures low distortion as well as low noise for processing audio signal delay. The chip provides two playing modes (echo and surround) and the playing function block diagrams are shown as follows.

- Echo mode

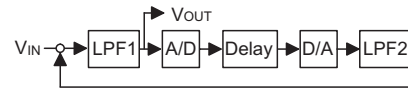

- Surround mode



Rosc-fosc-Delay_time-Distortion Cross table

Rosc	56.2	44	36.3	30.6	25.9	23.1	20.7	kΩ
fosc	2	2.5	3	3.5	4	4.5	5	MHz
Td	320	264	219	188	164	147	132	ms
THD	1.3	1.05	0.815	0.625	0.58	0.525	0.43	%

Rosc	18.5	16.7	15.1	14.5	13.9	11.9	10.9	kΩ
fosc	5.5	6	6.5	7	7.5	8	8.5	MHz
Td	120	110	102	93	88	82	78	ms
THD	0.4	0.335	0.315	0.3	0.275	0.26	0.25	%

Rosc	10	9	8.06	7.3	6.4	5.8	5.3	kΩ
fosc	9	10	11	12	13	14	15	MHz
Td	73.2	65.6	59.2	54.4	50	46	44	ms
THD	0.23	0.218	0.205	0.19	0.17	0.1675	0.1575	%

Rosc	4.8	4.4	4	3.7	3.3	3	2.8	kΩ
fosc	16	17	18	19	20	21	22	MHz
Td	41.2	38.4	36	33.6	33	32	30	ms
THD	0.16	0.145	0.14	0.14	0.13	0.125	0.12	%

Application Circuits

Echo Mode

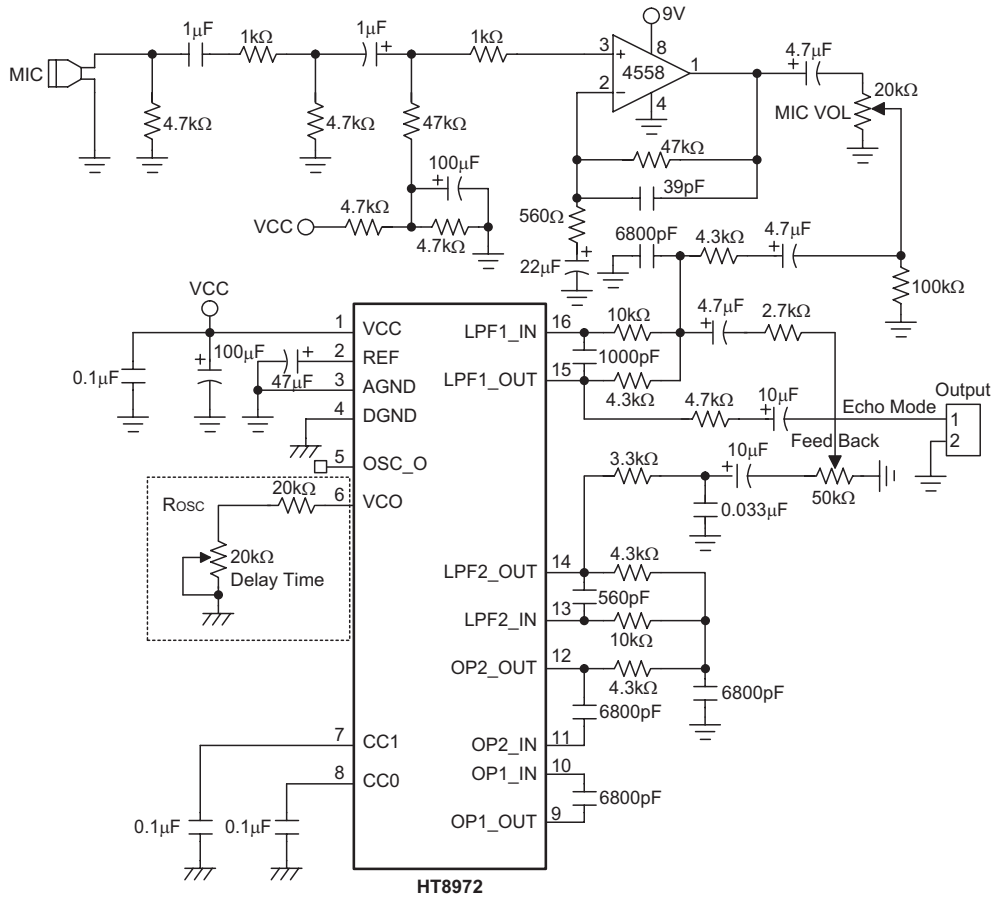

Note: 1. $\text{---}\text{||}\text{---}$: Analog ground, $\text{---}\text{||}\text{---}$: Digital ground

2. When the value of the R_{osc} increases, the range of the Delay time also increases. Please refer to the R_{osc} - f_{osc} -Delay_time-Distortion Cross table for the R_{osc} & Delay time values.

Surround Mode

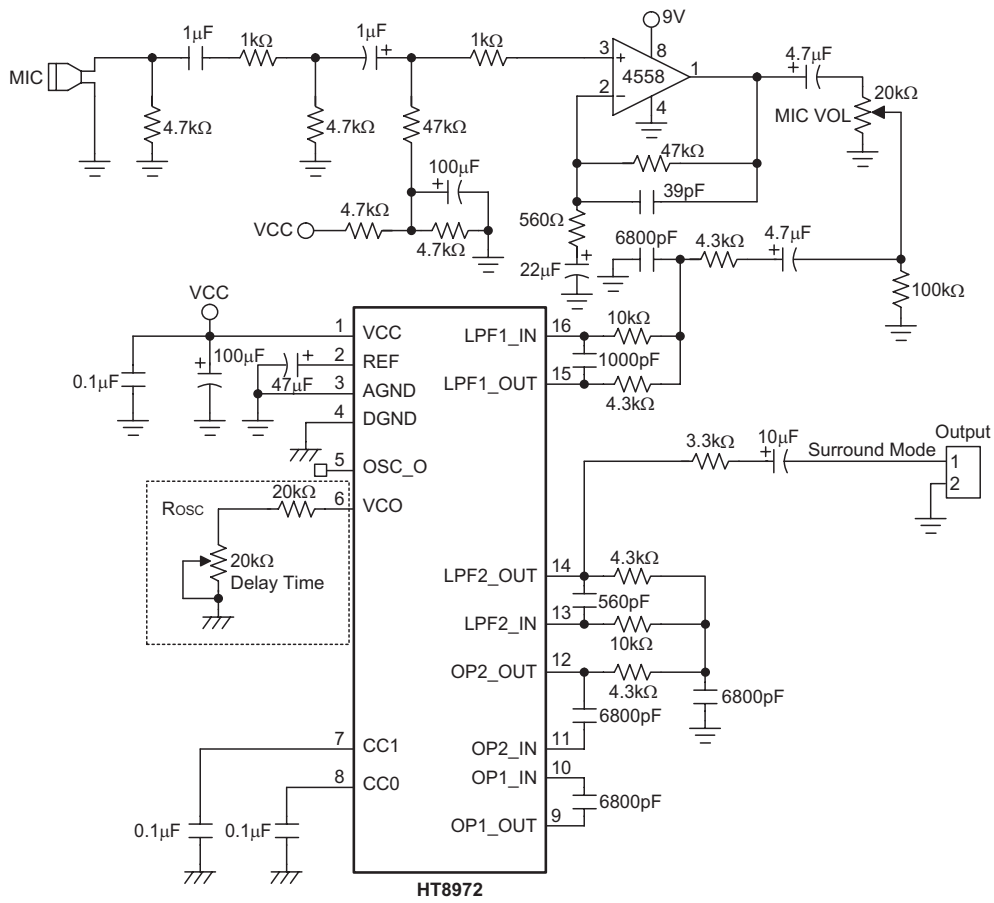

Note: 1. $\text{---}\text{---}\text{---}$: Analog ground, $\text{---}\text{---}\text{---}$: Digital ground

2. When the value of the R_{osc} increases, the range of the Delay time also increases. Please refer to the R_{osc} - f_{osc} -Delay_time-Distortion Cross table for the R_{osc} & Delay time values.

Package Information

16-pin DIP (300mil) Outline Dimensions

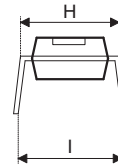
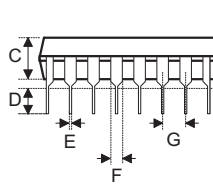
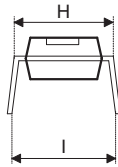
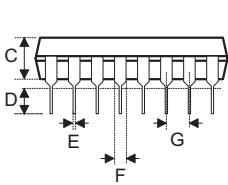
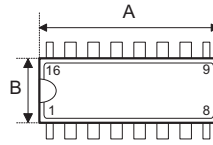
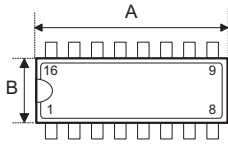

Fig1. Full Lead Packages

Fig2. 1/2 Lead Packages

- MS-001d (see fig1)

Symbol	Dimensions in mil		
	Min.	Nom.	Max.
A	780	—	880
B	240	—	280
C	115	—	195
D	115	—	150
E	14	—	22
F	45	—	70
G	—	100	—
H	300	—	325
I	—	—	430

- MS-001d (see fig2)

Symbol	Dimensions in mil		
	Min.	Nom.	Max.
A	735	—	775
B	240	—	280
C	115	—	195
D	115	—	150
E	14	—	22
F	45	—	70
G	—	100	—
H	300	—	325
I	—	—	430

- MO-095a (see fig2)

Symbol	Dimensions in mil		
	Min.	Nom.	Max.
A	745	—	785
B	275	—	295
C	120	—	150
D	110	—	150
E	14	—	22
F	45	—	60
G	—	100	—
H	300	—	325
I	—	—	430

16-pin SOP (300mil) Outline Dimensions

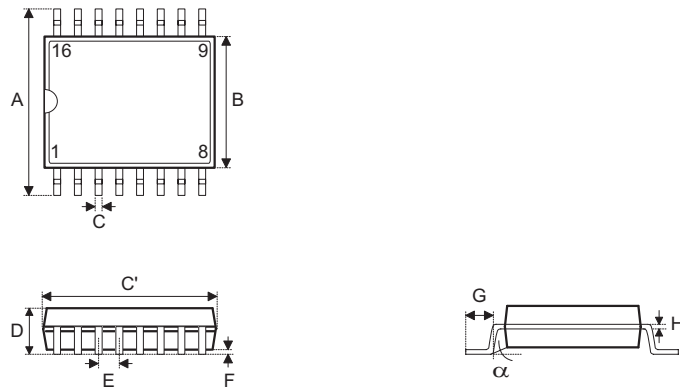

• MS-013

Symbol	Dimensions in mil		
	Min.	Nom.	Max.
A	393	—	419
B	256	—	300
C	12	—	20
C'	398	—	413
D	—	—	104
E	—	50	—
F	4	—	12
G	16	—	50
H	8	—	13
α	0°	—	8°

Product Tape and Reel Specifications

Reel Dimensions

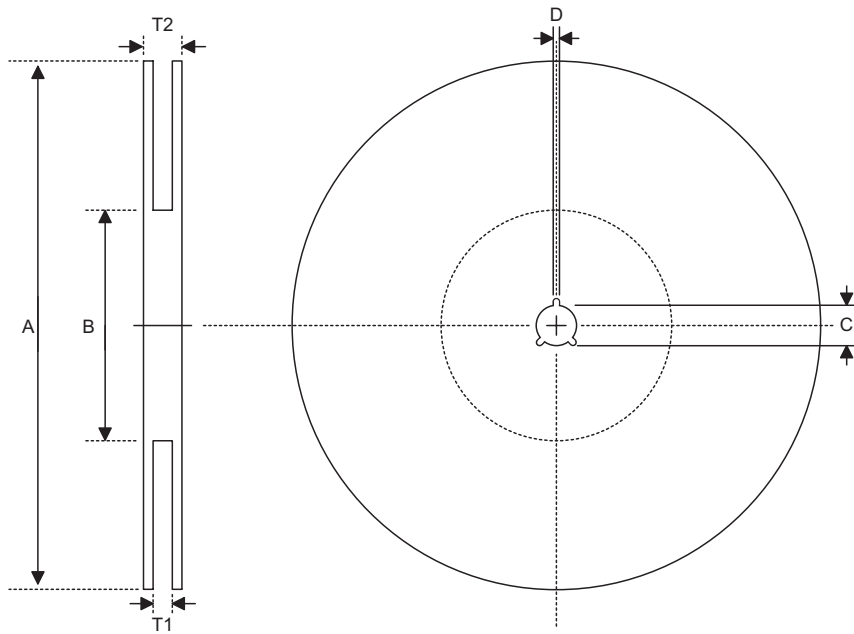

SOP 16W (300mil)

Symbol	Description	Dimensions in mm
A	Reel Outer Diameter	330.0±1.0
B	Reel Inner Diameter	100.0±1.5
C	Spindle Hole Diameter	13.0 ^{+0.5/-0.2}
D	Key Slit Width	2.0±0.5
T1	Space Between Flange	16.8 ^{+0.3/-0.2}
T2	Reel Thickness	22.2±0.2

Carrier Tape Dimensions

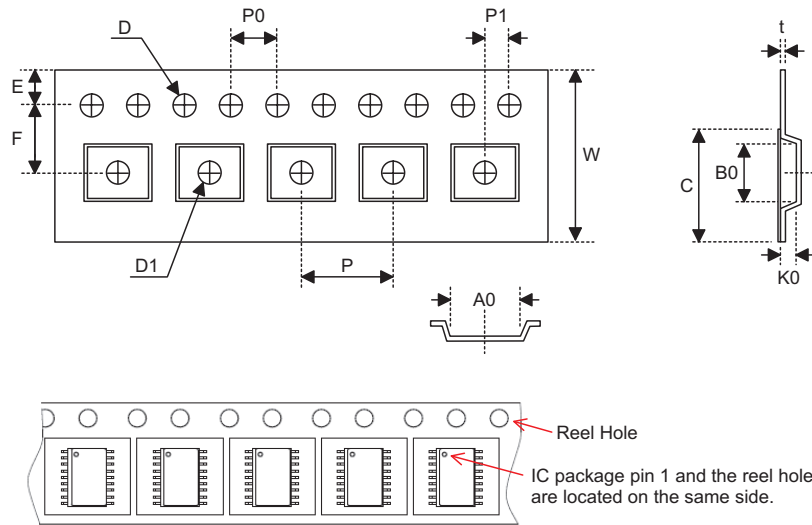

SOP 16W (300mil)

Symbol	Description	Dimensions in mm
W	Carrier Tape Width	16.0±0.2
P	Cavity Pitch	12.0±0.1
E	Perforation Position	1.75±0.10
F	Cavity to Perforation (Width Direction)	7.5±0.1
D	Perforation Diameter	1.50 ^{+0.10/-0.00}
D1	Cavity Hole Diameter	1.50 ^{+0.25/-0.00}
P0	Perforation Pitch	4.0±0.1
P1	Cavity to Perforation (Length Direction)	2.0±0.1
A0	Cavity Length	10.9±0.1
B0	Cavity Width	10.8±0.1
K0	Cavity Depth	3.0±0.1
t	Carrier Tape Thickness	0.30±0.05
C	Cover Tape Width	13.3±0.1

Copyright © 2008 by HOLTEK SEMICONDUCTOR INC.

The information appearing in this Data Sheet is believed to be accurate at the time of publication. However, Holtek assumes no responsibility arising from the use of the specifications described. The applications mentioned herein are used solely for the purpose of illustration and Holtek makes no warranty or representation that such applications will be suitable without further modification, nor recommends the use of its products for application that may present a risk to human life due to malfunction or otherwise. Holtek's products are not authorized for use as critical components in life support devices or systems. Holtek reserves the right to alter its products without prior notification. For the most up-to-date information, please visit our web site at <http://www.holtek.com.tw>.