

Features

- Operating voltage: 4.5V~5.5V
- ADM algorithm
- Low noise
 - Echo mode: -85dB
 - Surround mode: -90dB
- Built-in 20Kb SRAM
- Automatic reset function
- 16-pin DIP/SOP package

Applications

- Television
- Karaoke systems
- Video disc player
- Sound equipments

General Description

The HT8970 is an echo/surround effect processor. It is designed for various audio systems including karaoke, television, sound equipments, etc. The chip consists of a built-in pre-amplifier, VCO or Voltage Control OSC, 20Kb SRAM, A/D and D/A converters as well as delay time control logic.

Its built-in 20Kb SRAM can generate delay time effect and can control the delay time value through the external VCO resistor.

The VCO circuit can reduce external components and make it easy to adjust the delay time.

Block Diagram

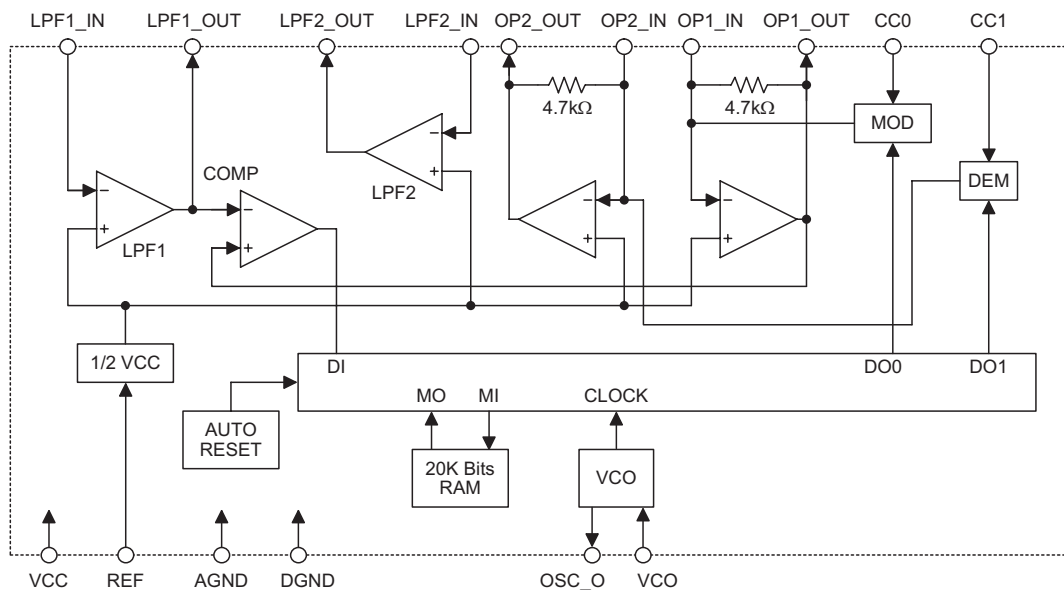

Pin Assignment

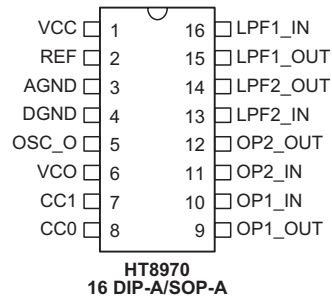

Pad Assignment

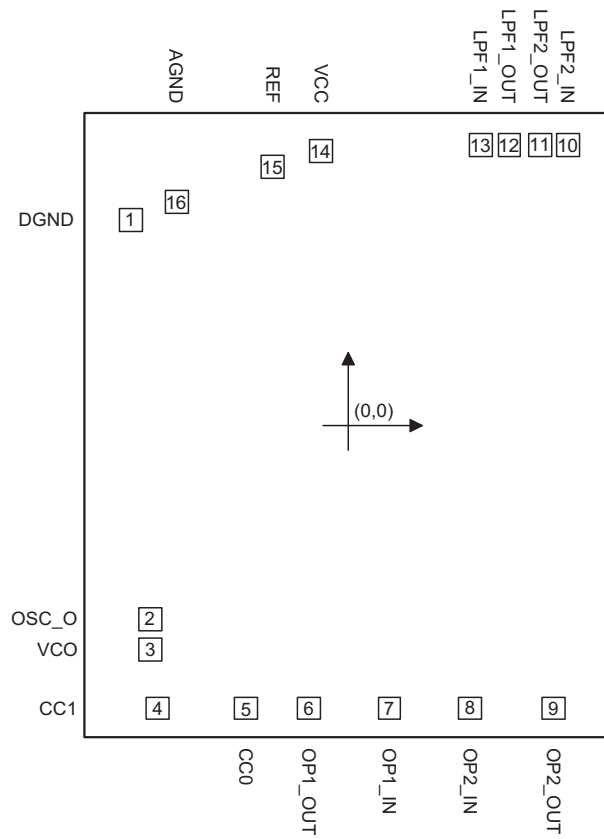

The IC substrate should be connected to VSS in the PCB layout artwork.

Pad Coordinates

 Unit: μm

Pad No.	X	Y
1	-730.950	688.300
2	-668.800	-652.050
3	-668.800	-755.050
4	-642.650	-951.700
5	-344.900	-951.700
6	-134.150	-951.700
7	135.100	-951.700
8	406.400	-951.700
9	687.400	-951.700
10	735.950	941.950
11	640.950	941.950
12	537.950	941.950
13	442.950	941.950
14	-94.000	920.850
15	-256.650	868.650
16	-578.400	749.850

Pad Description

Pad No.	Pad Name	I/O	Description
1	DGND	I	Digital ground
2	OSC_O	O	System oscillator output
3	VCO	I	System oscillator input, system frequency adjustable pin
4	CC1	—	Current control 1
5	CC0	—	Current control 0
6	OP1_OUT	O	OP1 output
7	OP1_IN	I	OP1 input
8	OP2_IN	I	OP2 input
9	OP2_OUT	O	OP2 output
10	LPF2_IN	I	Low pass filter 2 input
11	LPF2_OUT	O	Low pass filter 2 output
12	LPF1_OUT	O	Low pass filter 1 output
13	LPF1_IN	I	Low pass filter 1 input
14	VCC	I	Analog and positive power supply
15	REF	I	Analog reference voltage
16	AGND	I	Analog ground

Absolute Maximum Ratings

Supply Voltage..... $V_{SS}-0.3V$ to $V_{DD}+6V$	Storage Temperature..... $-50^{\circ}C$ to $125^{\circ}C$
Input Voltage..... $V_{SS}-0.3V$ to $V_{DD}+0.3V$	Operating Temperature..... $-20^{\circ}C$ to $70^{\circ}C$

Note: These are stress ratings only. Stresses exceeding the range specified under "Absolute Maximum Ratings" may cause substantial damage to the device. Functional operation of this device at other conditions beyond those listed in the specification is not implied and prolonged exposure to extreme conditions may affect device reliability.

Electrical Characteristics

 $T_a=25^{\circ}C$

Symbol	Parameter	Test Conditions		Min.	Typ.	Max.	Unit
		V_{DD}	Conditions				
V_{CC}	Operating Voltage	—	—	4.5	5.0	5.5	V
I_{CC}	Operating Current	5V	—	—	15	30	mA
G_V	Voltage Gain	5V	$R_L=47k\Omega$	—	-0.9	2.5	dB
V_{OMAX}	Maximum Output Voltage	5V	THD=10%	0.9	1.8	—	Vrms
N_O	Output Noise Voltage	5V	DIN Audio	—	-85	-60	dBV
PSRR	Power Supply Rejection Ratio	5V	$\Delta V_{CC}=-20dBV$ (0.1Vrms) $f=100Hz$	—	-40	-30	dB

Functional Description

The HT8970 is an echo/surround effect generator with built-in 20Kb SRAM. The chip provides two playing modes (echo and surround) and the playing function block diagrams are shown as follows.

- Echo mode

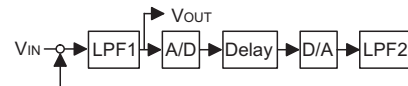

- Surround mode



R_{osc} - f_{osc} -Delay_time Cross Table

R_{osc}	56.6	44.8	36.2	30.4	26.0	23.2	20.6	$k\Omega$
f_{osc}	2.0	2.5	3.0	3.5	4.0	4.5	5.0	MHz
T_d	326	260	218	188	162	146	130	ms

R_{osc}	18.3	16.6	15	14.2	13.4	12.5	11.6	$k\Omega$
f_{osc}	5.5	6.0	6.5	7.0	7.5	8.0	8.5	MHz
T_d	119	110	102	94.4	88	82.4	76.8	ms

R_{osc}	10.8	9.5	8.4	7.6	6.8	6.3	5.6	$k\Omega$
f_{osc}	9	10	11	12	13	14	15	MHz
T_d	73.2	64.8	59.2	54.4	50.0	46.4	42.8	ms

R_{osc}	5.00	4.09	3.68	3.42	3.08	2.84	2.65	$k\Omega$
f_{osc}	16	17	18	19	20	21	22	MHz
T_d	40.4	38.4	36.4	34.2	32.8	31.0	29.6	ms

Application Circuits

Echo Mode

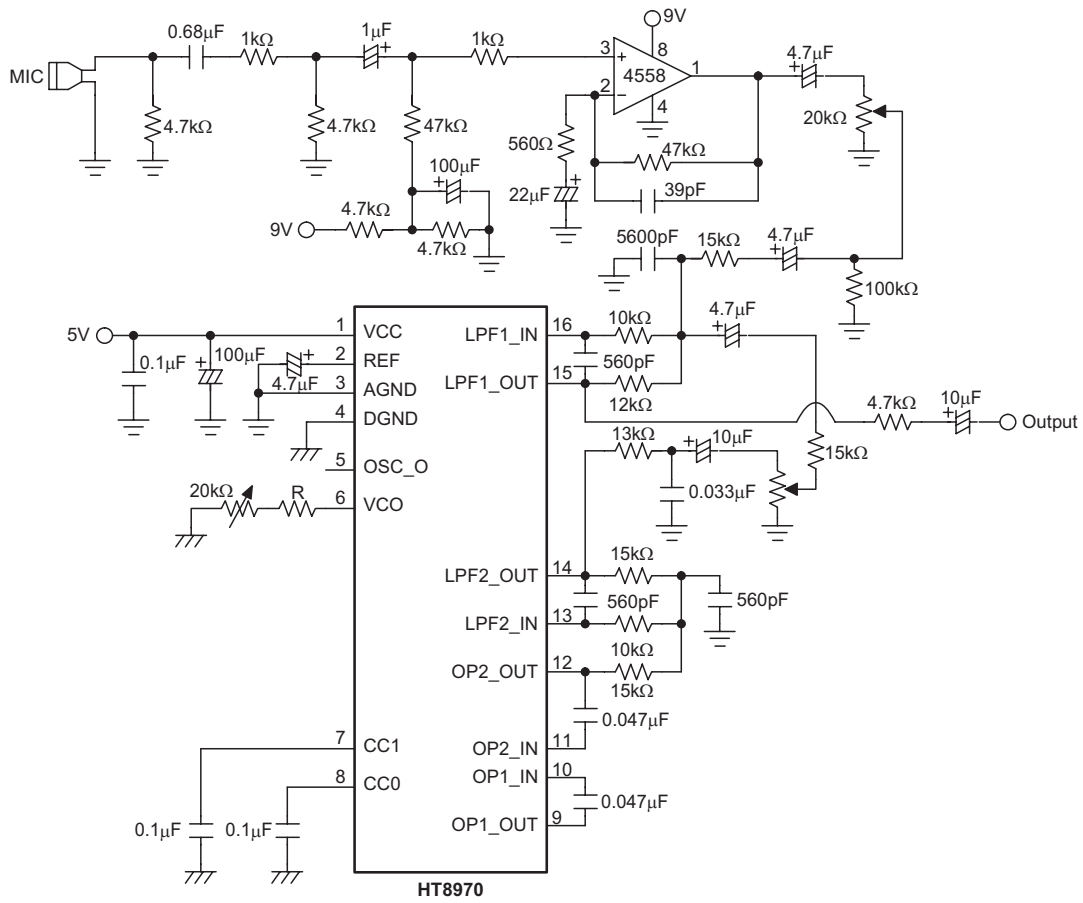



Note:  : Analog ground,  : Digital ground

When the value of the R_{OSC} increases, the range of the Delay time also increases. Please refer to the $R_{OSC} - f_{OSC} - Delay_time$ Cross table for the R_{OSC} & Delay time values.

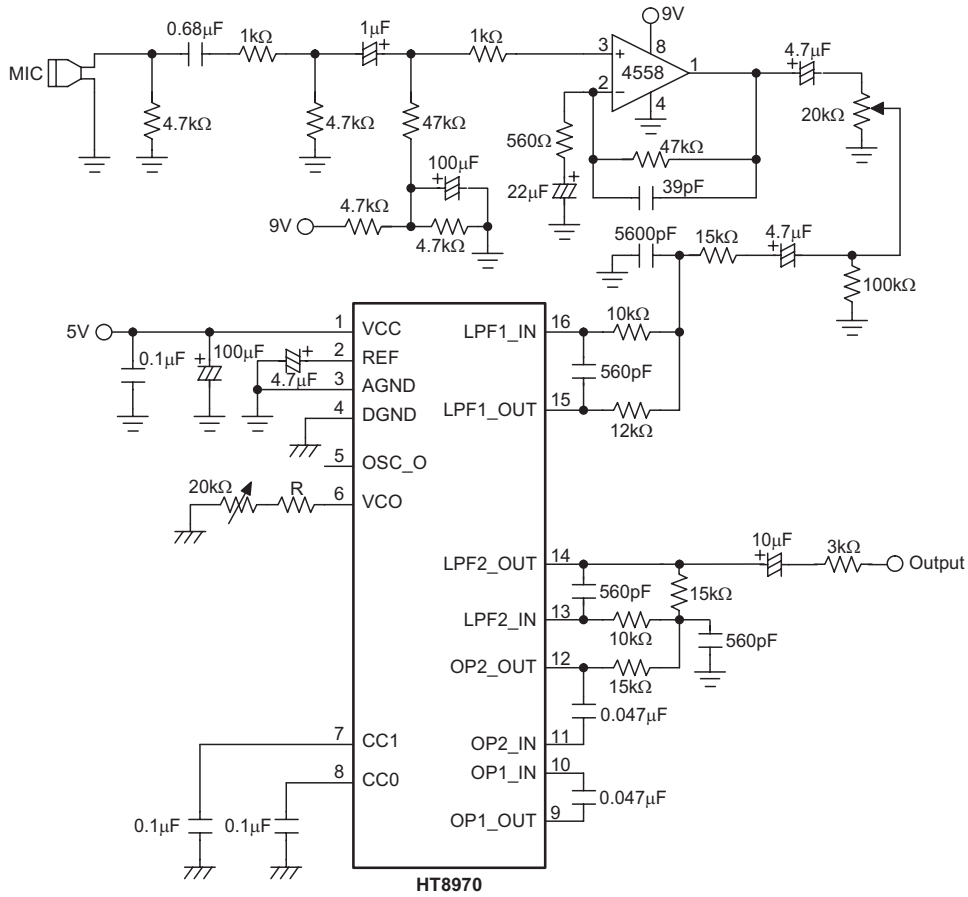
Surround Mode



Note: : Analog ground, : Digital ground

When the value of the R_{OSC} increases, the range of the Delay time also increases. Please refer to the $R_{OSC} - f_{osc} - Delay_time$ Cross table for the R_{OSC} & Delay time values.

Package Information

16-pin DIP (300mil) Outline Dimensions

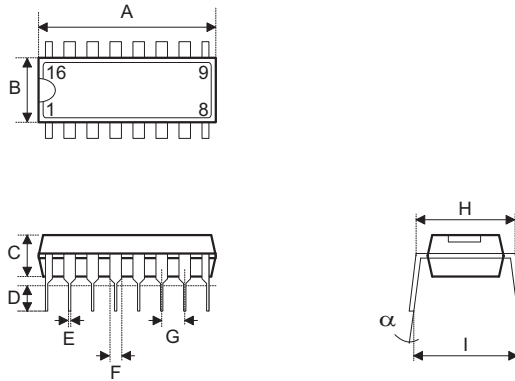

Symbol	Dimensions in mil		
	Min.	Nom.	Max.
A	745	—	775
B	240	—	260
C	125	—	135
D	125	—	145
E	16	—	20
F	50	—	70
G	—	100	—
H	295	—	315
I	335	—	375
α	0°	—	15°

16-pin SOP (300mil) Outline Dimensions

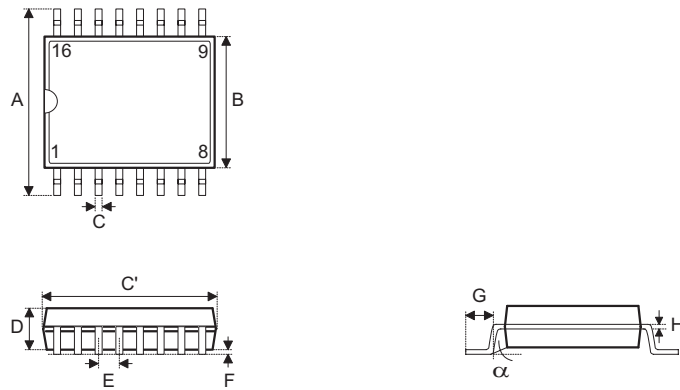

Symbol	Dimensions in mil		
	Min.	Nom.	Max.
A	394	—	419
B	290	—	300
C	14	—	20
C'	390	—	413
D	92	—	104
E	—	50	—
F	4	—	—
G	16	—	50
H	4	—	12
α	0°	—	10°

Product Tape and Reel Specifications

Reel Dimensions

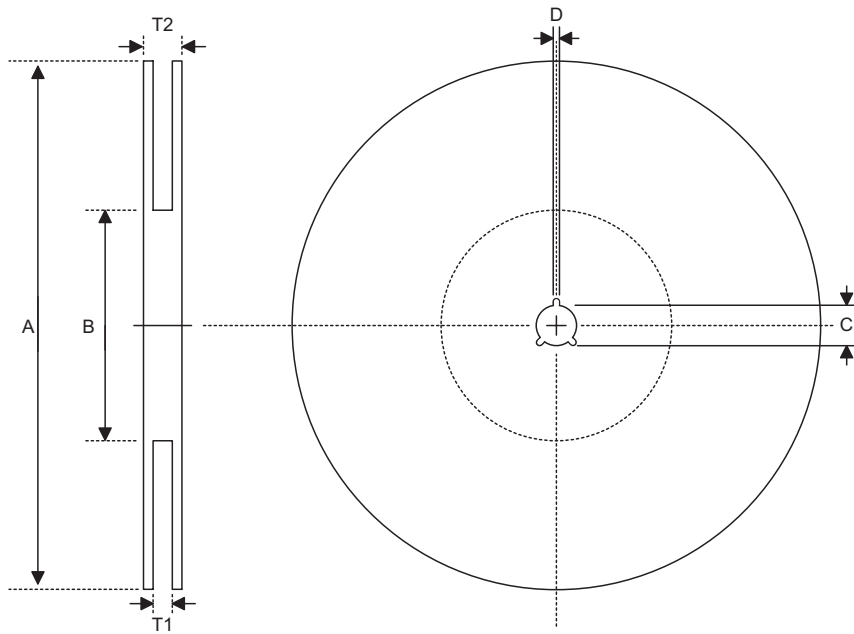

SOP 16W (300mil)

Symbol	Description	Dimensions in mm
A	Reel Outer Diameter	330±1
B	Reel Inner Diameter	62±1.5
C	Spindle Hole Diameter	13.0±0.5 -0.2
D	Key Slit Width	2±0.5
T1	Space Between Flange	16.8+0.3 -0.2
T2	Reel Thickness	22.2±0.2

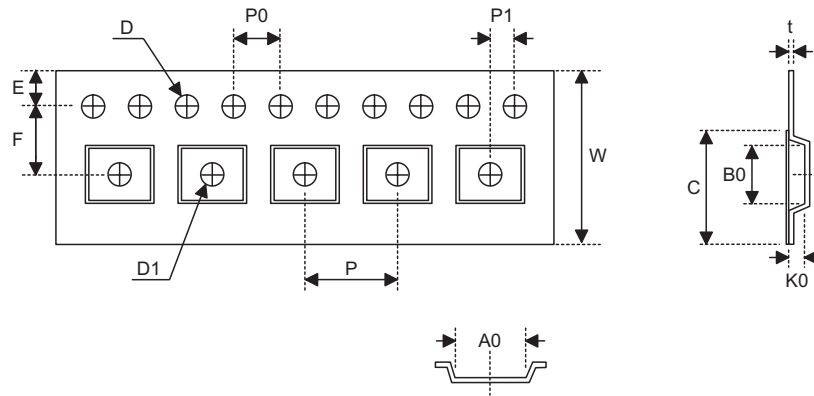
Carrier Tape Dimensions

SOP 16W (300mil)

Symbol	Description	Dimensions in mm
W	Carrier Tape Width	16±0.2
P	Cavity Pitch	12±0.1
E	Perforation Position	1.75±0.1
F	Cavity to Perforation (Width Direction)	7.5±0.1
D	Perforation Diameter	1.5±0.1
D1	Cavity Hole Diameter	1.5±0.25
P0	Perforation Pitch	4±0.1
P1	Cavity to Perforation (Length Direction)	2±0.1
A0	Cavity Length	10.9±0.1
B0	Cavity Width	10.8±0.1
K0	Cavity Depth	3±0.1
t	Carrier Tape Thickness	0.3±0.05
C	Cover Tape Width	13.3

Copyright © 2008 by HOLTEK SEMICONDUCTOR INC.

The information appearing in this Data Sheet is believed to be accurate at the time of publication. However, Holtek assumes no responsibility arising from the use of the specifications described. The applications mentioned herein are used solely for the purpose of illustration and Holtek makes no warranty or representation that such applications will be suitable without further modification, nor recommends the use of its products for application that may present a risk to human life due to malfunction or otherwise. Holtek's products are not authorized for use as critical components in life support devices or systems. Holtek reserves the right to alter its products without prior notification. For the most up-to-date information, please visit our web site at <http://www.holtek.com.tw>.