

Features

- Wide operating voltage: 1.4V to 5.5V
- Low quiescent current: typical 0.6μA/amplifier
- Rail-to-Rail output
- Gain bandwidth: 11kHz typical
- Unity gain stable
- Available in Single, Dual and Quad OP's package types
- Package type:
 - HT9291: TSOT23-5
 - HT9292: 8-pin DIP/SOP
 - HT9294: 14-pin DIP/SOP

Applications

- Wearable products
- Temperature measurement
- Battery powered products
- Portable equipment
- Low power sensors

General Description

The Holtek HT9291/HT9292/HT9294 range of Low Power Operation Amplifiers offer the advantage of a single supply voltage down to as low as 1.4V as well as the advantages of an extremely low quiescent current of only 0.6μA/amplifier. One other major advantage of these devices lie in their rail-to-rail voltage operation for maximum range. The devices also provide a typical gain bandwidth product of 11kHz and are also unity gain sta-

ble. The devices are available in a range of packages according the number of internal amplifiers. The special characteristics of these devices will ensure their excellent use in applications with stringent low power demands such as portable products, battery powered equipment, low power sensor signal processing etc.

Selection Table

Part No.	Amplifiers	Package
HT9291	1	TSOT23-5
HT9292	2	8DIP/SOP
HT9294	4	14DIP/SOP

Block Diagram

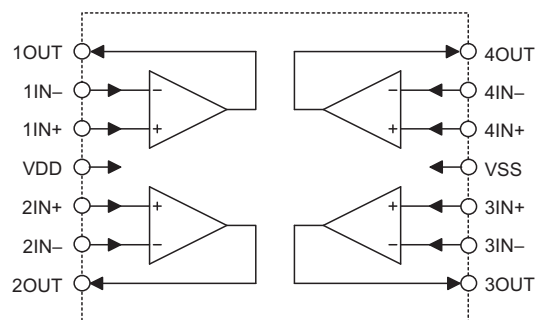

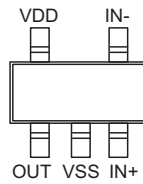
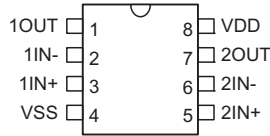
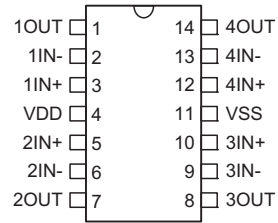
Pin Assignment

HT9291
TSOT23-5

HT9292
8 DIP-A/SOP-A

HT9294
14 DIP-A/SOP-A
Pin Descriptions
HT9291

Pin No.	Pin Name	Description
1	OUT	Analog output
2	VSS	Negative power supply
3	IN+	Non-inverting input
4	IN-	Inverting input
5	VDD	Positive power supply

HT9292

Pin No.	Pin Name	Description
1	1OUT	Analog output (operation amplifier 1)
2	1IN-	Inverting input (operation amplifier 1)
3	1IN+	Non-inverting input (operation amplifier 1)
4	VSS	Negative power supply
5	2IN+	Non-inverting input (operation amplifier 2)
6	2IN-	Inverting input (operation amplifier 2)
7	2OUT	Analog output (operation amplifier 2)
8	VDD	Positive power supply

HT9294

Pin No.	Pin Name	Description
1	1OUT	Analog output (operation amplifier 1)
2	1IN-	Inverting input (operation amplifier 1)
3	1IN+	Non-inverting input (operation amplifier 1)
4	VDD	Positive power supply
5	2IN+	Non-inverting input (operation amplifier 2)
6	2IN-	Inverting input (operation amplifier 2)
7	2OUT	Analog output (operation amplifier 2)
8	3OUT	Analog output (operation amplifier 3)
9	3IN-	Inverting input (operation amplifier 3)
10	3IN+	Non-inverting input (operation amplifier 3)
11	VSS	Negative power supply
12	4IN+	Non-inverting input (operation amplifier 4)
13	4IN-	Inverting input (operation amplifier 4)
14	4OUT	Analog output (operation amplifier 4)

Absolute Maximum Ratings

Supply Voltage	6.0V	Input Voltage.....	$V_{SS}-0.3V \sim V_{DD}+0.3V$
Difference Input Voltage.....	$\pm(V_{DD}-V_{SS})$	ESD protection on all pins (HBM;MM)	$\geq 4kV; 400V$
Storage Temperature	$-65^{\circ}C$ to $+150^{\circ}C$	Operating Temperature	$-40^{\circ}C$ to $+85^{\circ}C$
Junction Temperature	$150^{\circ}C$		

Note: These are stress ratings only. Stresses exceeding the range specified under "Absolute Maximum Ratings" may cause substantial damage to the device. Functional operation of this device at other conditions beyond those listed in the specification is not implied and prolonged exposure to extreme conditions may affect device reliability.

Electrical Characteristics

Unless otherwise indicated, $V_{SS}=GND$, $T_a=25^{\circ}C$, $V_{CM}=V_{DD}/2$, $V_L=V_{DD}/2$, and $R_L=1M\Omega$ to V_L , $C_L=60pF$

Symbol	Parameter	Test Conditions		Min.	Typ.	Max.	Unit
		V_{DD}	Conditions				
V_{DD}	Supply Voltage	—	—	1.4	—	5.5	V
V_{OS}	Input Offset Voltage	5V	$V_{IN}=V_{CM}/2$	-5.0	—	5.0	mV
$\Delta V_{OS}/\Delta T$	Drift with Temperature	5V	$V_{IN}=V_{CM}/2$	—	± 2	—	$\mu V/^{\circ}C$
I_{OS}	Input Offset Current	5V	$T_a=25^{\circ}C$	—	± 5	—	pA
I_B	Input Bias Current	5V	$T_a=25^{\circ}C$	—	± 50	—	pA
V_{CM}	Input Common Mode Range	5V	—	0	—	$V_{DD}-1.2$	V
V_{OH} V_{OL}	Maximum Output Voltage Swing	5V	0.5V input overdrive $R_L=1M\Omega$ to V_L	$V_{SS}+10$	—	$V_{DD}-10$	mV
			0.5V input overdrive $R_L=50k\Omega$ to V_L	$V_{SS}+20$	—	$V_{DD}-50$	mV
A_{OL}	DC Open-Loop Gain (large signal)	5V	$V_{OUT}=0.2V$ to $V_{DD}-0.2V$, $V_{IN}=V_{CM}/2$	70	100	—	dB
GBW	Gain BandWidth Product	5V	$R_L=1M\Omega$, $C_L=60pF$ $V_{IN}=V_{CM}/2$	—	11	—	kHz
Φ_m	Phase Margin	5V	$R_L=1M\Omega$, $C_L=60pF$ $G=+1V/V$, $V_{IN+}=V_{DD}/2$	—	50	—	$^{\circ}$
CMRR	Common Mode Rejection Ratio	5V	$V_{CM}=0V$ to $V_{DD}-1.4V$	60	90	—	dB
PSRR	Power Supply Rejection Ratio	5V	$V_{CM}=0.2V$	65	95	—	dB
I_{CC}	Supply Current Per Single Amplifier	5V	$I_o=0A$ for HT9291	0.50	0.80	1.20	μA
			$I_o=0A$ for HT9292/HT9294	0.30	0.60	1.00	μA
SR	Slew Rate at Unity Gain	5V	$R_L=1M\Omega$, $C_L=60pF$	—	5	—	V/ms
I_{O_SOURCE}	Output Short Circuit Source Current	5V	$V_{IN+} - V_{IN-} \geq 10mV$	-0.3	-1.2	—	mA
I_{O_SINK}	Output Short Circuit Sink Current	5V	$V_{IN-} - V_{IN+} \geq 10mV$	1	4	—	mA

Functional Description

Input Stage

The input stage of op amps are nominal PMOS differential amplifiers (see the following diagram), therefore the common mode input voltage can extend to $V_{SS}-0.6V$. On the other hand the common mode input voltage has to be maintained below $(V_{DD}-1.2V)$ to keep the input device (M2 and M3) active. This implies that when using HT9291/HT9292/HT9294 as a voltage follower, the input as well as output active range will be limited between $V_{SS}\sim V_{DD}-1V$ (approx.). Avoid applying any voltage greater than $V_{DD}+0.6V$ or less than $V_{SS}-0.6V$ to the input pins, otherwise the internal input protection devices may be damaged.

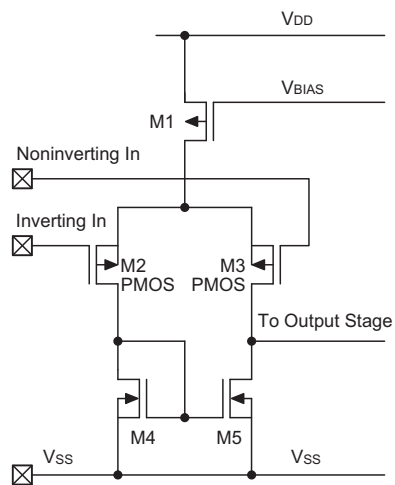

Since the input impedance of PMOS is inherently very high, it can directly couple to high impedance elements without loading effect. For example, coupling to ceramic transducers, integrating capacitor and resistor networks.

Actually the extremely high input impedance is its major advantage over the bipolar counterpart, in some application fields such as integrators where the input current of op amp can cause significant error.

Output Stage

The HT9291/HT9292/HT9294 uses push-pull CMOS configuration as the output stage of op amps to minimize low power consumption and to provide adequate output driving current.

Note that the output is an unbuffered structure, therefore the open loop gain will be affected by the load resistor since the voltage gain of this stage can be expressed as $(gm5+ gm6)\times R_L$.

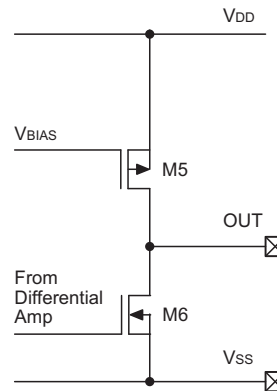

Because of the consideration for minimized power consumption, the output short circuit current is limited to about $-1.2mA$ for source drive and $4mA$ for sink drive. This is believed to be enough for most low power systems, however it is recommended to use the load resistor of $>1M\Omega$ for normal applications. In case of heavy load driving, an external buffer stage using bipolar transistors is recommended.

The HT9291/HT9292/HT9294 is internally compensated for AC stability and capable to withstand up to a $60pF$ capacitive load.

Application Circuits

High Side Battery Current Sensor

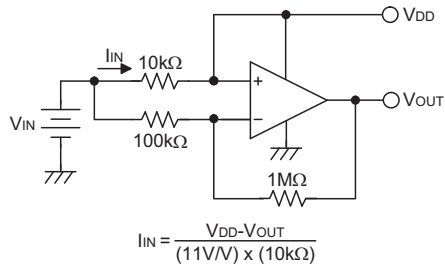

Two Op Amp Instrumentation Amplifier

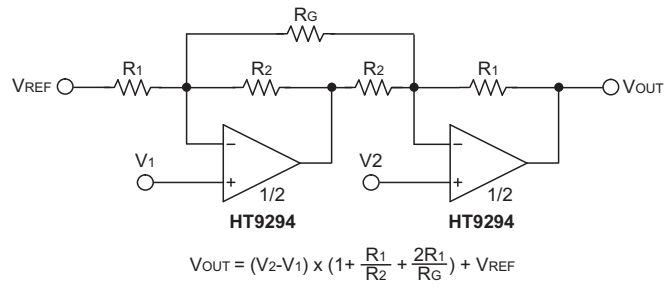

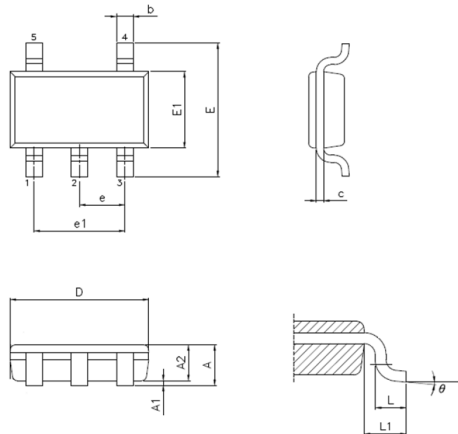
Package Information
5-pin TSOT23-5 Outline Dimensions

• MO-193C

Symbol	Dimensions in inch		
	Min.	Nom.	Max.
A	—	—	0.043
A1	0.000	—	0.004
A2	0.028	—	0.039
b	0.012	—	0.020
C	0.003	—	0.008
D	—	0.114	—
E	—	0.110	—
E1	—	0.063	—
e	—	0.037	—
e1	—	0.075	—
L	0.012	—	0.024
L1	—	0.024	—
θ	0°	—	8°

Symbol	Dimensions in mm		
	Min.	Nom.	Max.
A	—	—	1.10
A1	0.00	—	0.10
A2	0.70	—	1.00
b	0.30	—	0.50
C	0.08	—	0.20
D	—	2.90	—
E	—	2.80	—
E1	—	1.60	—
e	—	0.95	—
e1	—	1.90	—
L	0.30	—	0.60
L1	—	0.60	—
θ	0°	—	8°

8-pin DIP (300mil) Outline Dimensions

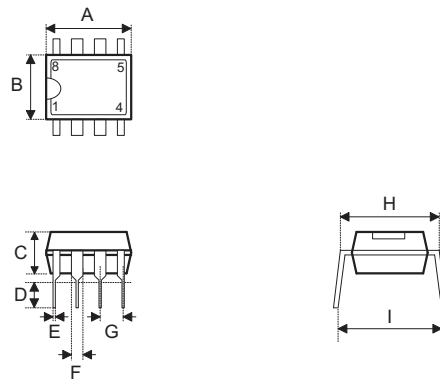

Symbol	Dimensions in inch		
	Min.	Nom.	Max.
A	0.355	—	0.375
B	0.240	—	0.260
C	0.125	—	0.135
D	0.125	—	0.145
E	0.016	—	0.020
F	0.050	—	0.070
G	—	0.100	—
H	0.295	—	0.315
I	—	0.375	—

Symbol	Dimensions in mm		
	Min.	Nom.	Max.
A	9.02	—	9.53
B	6.10	—	6.60
C	3.18	—	3.43
D	3.18	—	3.68
E	0.41	—	0.51
F	1.27	—	1.78
G	—	2.54	—
H	7.49	—	8.00
I	—	9.53	—

14-pin DIP (300mil) Outline Dimensions

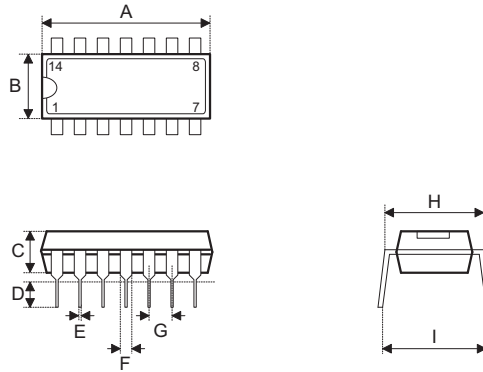

Symbol	Dimensions in inch		
	Min.	Nom.	Max.
A	0.745	—	0.775
B	0.240	—	0.260
C	0.125	—	0.135
D	0.125	—	0.145
E	0.016	—	0.020
F	0.050	—	0.070
G	—	0.1100	—
H	0.295	—	0.315
I	—	0.375	—

Symbol	Dimensions in mm		
	Min.	Nom.	Max.
A	18.92	—	19.69
B	6.10	—	6.60
C	3.18	—	3.43
D	3.18	—	3.68
E	0.41	—	0.51
F	1.27	—	1.78
G	—	2.54	—
H	7.49	—	8.00
I	—	9.53	—

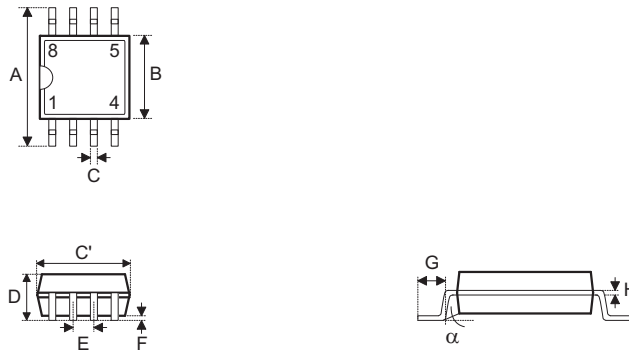
8-pin SOP (150mil) Outline Dimensions

• MS-012

Symbol	Dimensions in inch		
	Min.	Nom.	Max.
A	0.228	—	0.244
B	0.150	—	0.157
C	0.012	—	0.020
C'	0.188	—	0.197
D	—	—	0.069
E	—	0.050	—
F	0.004	—	0.010
G	0.016	—	0.050
H	0.007	—	0.010
α	0°	—	8°

Symbol	Dimensions in mm		
	Min.	Nom.	Max.
A	5.79	—	6.20
B	3.81	—	3.99
C	0.30	—	0.51
C'	4.78	—	5.00
D	—	—	1.75
E	—	1.27	—
F	0.10	—	0.25
G	0.41	—	1.27
H	0.18	—	0.25
α	0°	—	8°

14-pin SOP (150mil) Outline Dimensions

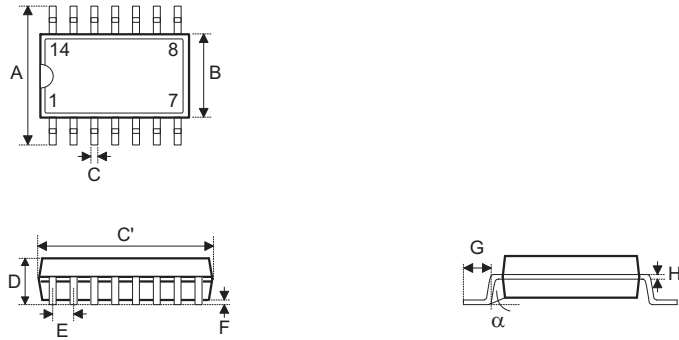

• MS-012

Symbol	Dimensions in inch		
	Min.	Nom.	Max.
A	0.228	—	0.244
B	0.150	—	0.157
C	0.012	—	0.020
C'	0.337	—	0.344
D	—	—	0.069
E	—	0.050	—
F	0.004	—	0.010
G	0.016	—	0.050
H	0.007	—	0.010
α	0°	—	8°

Symbol	Dimensions in mm		
	Min.	Nom.	Max.
A	5.79	—	6.20
B	3.81	—	3.99
C	0.30	—	0.51
C'	8.56	—	8.74
D	—	—	1.75
E	—	1.27	—
F	0.10	—	0.25
G	0.41	—	1.27
H	0.18	—	0.25
α	0°	—	8°

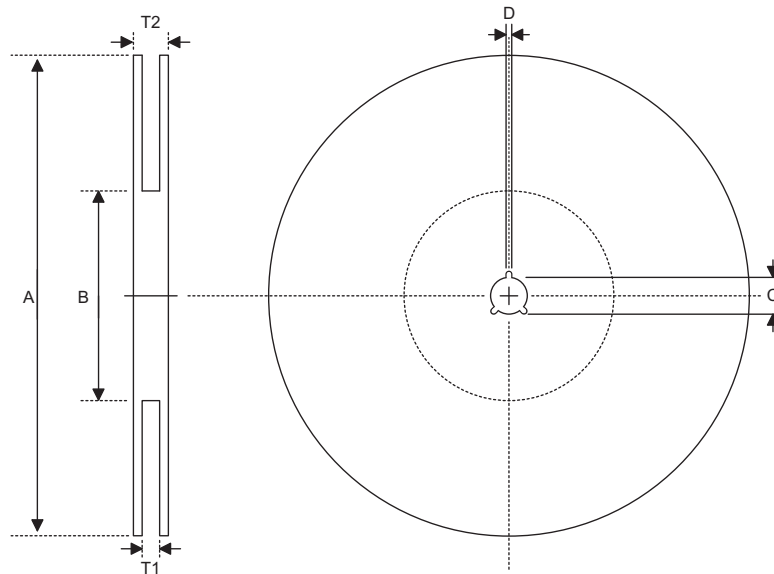
Product Tape and Reel Specifications

Reel Dimensions

SOP 8N

Symbol	Description	Dimensions in mm
A	Reel Outer Diameter	330.0±1.0
B	Reel Inner Diameter	100.0±1.5
C	Spindle Hole Diameter	13.0 ^{+0.5/-0.2}
D	Key Slit Width	2.0±0.5
T1	Space Between Flange	12.8 ^{+0.3/-0.2}
T2	Reel Thickness	18.2±0.2

SOP 14N

Symbol	Description	Dimensions in mm
A	Reel Outer Diameter	330.0±1.0
B	Reel Inner Diameter	100.0±1.5
C	Spindle Hole Diameter	13.0 ^{+0.5/-0.2}
D	Key Slit Width	2.0±0.5
T1	Space Between Flange	16.8 ^{+0.3/-0.2}
T2	Reel Thickness	22.2±0.2

TSOT23-5

Symbol	Description	Dimensions in mm
A	Reel Outer Diameter	178.0±1.0
B	Reel Inner Diameter	60.0±1.0
C	Spindle Hole Diameter	13.0 ^{+0.5/-0.2}
D	Key Slit Width	2.4±0.1
T1	Space Between Flange	9.0±0.5
T2	Reel Thickness	11.8±0.5

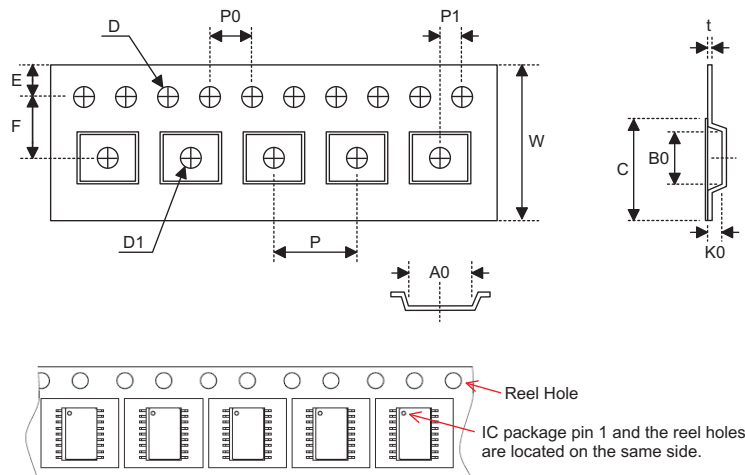
Carrier Tape Dimensions

SOP 8N

Symbol	Description	Dimensions in mm
W	Carrier Tape Width	12.0 ^{+0.3/-0.1}
P	Cavity Pitch	8.0±0.1
E	Perforation Position	1.75±0.1
F	Cavity to Perforation (Width Direction)	5.5±0.1
D	Perforation Diameter	1.55±0.1
D1	Cavity Hole Diameter	1.50 ^{+0.25/-0.00}
P0	Perforation Pitch	4.0±0.1
P1	Cavity to Perforation (Length Direction)	2.0±0.1
A0	Cavity Length	6.4±0.1
B0	Cavity Width	5.2±0.1
K0	Cavity Depth	2.1±0.1
t	Carrier Tape Thickness	0.30±0.05
C	Cover Tape Width	9.3±0.1

SOP 14N

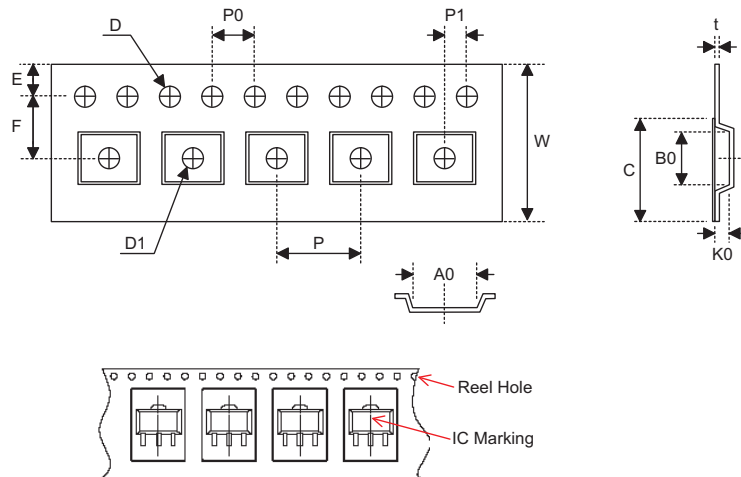
Symbol	Description	Dimensions in mm
W	Carrier Tape Width	16.0 ^{+0.3/-0.1}
P	Cavity Pitch	8.0±0.1
E	Perforation Position	1.75±0.1
F	Cavity to Perforation (Width Direction)	7.5±0.1
D	Perforation Diameter	1.5 ^{+0.1/-0.0}
D1	Cavity Hole Diameter	1.50 ^{+0.25/-0.00}
P0	Perforation Pitch	4.0±0.1
P1	Cavity to Perforation (Length Direction)	2.0±0.1
A0	Cavity Length	6.5±0.1
B0	Cavity Width	9.5±0.1
K0	Cavity Depth	2.1±0.1
t	Carrier Tape Thickness	0.30±0.05
C	Cover Tape Width	13.3±0.1

Carrier Tape Dimensions

TSOT23-5

Symbol	Description	Dimensions in mm
W	Carrier Tape Width	8.0±0.2
P	Cavity Pitch	4.0±0.1
E	Perforation Position	1.75±0.10
F	Cavity to Perforation (Width Direction)	3.50±0.05
D	Perforation Diameter	1.5 ^{+0.1/-0.0}
D1	Cavity Hole Diameter	1.1 ^{+0.1/-0.0}
P0	Perforation Pitch	4.0±0.1
P1	Cavity to Perforation (Length Direction)	2.00±0.05
A0	Cavity Length	3.2±0.1
B0	Cavity Width	3.2±0.1
K0	Cavity Depth	1.1±0.1
t	Carrier Tape Thickness	0.25±0.05
C	Cover Tape Width	5.3±0.1

Copyright © 2010 by HOLTEK SEMICONDUCTOR INC.

The information appearing in this Data Sheet is believed to be accurate at the time of publication. However, Holtek assumes no responsibility arising from the use of the specifications described. The applications mentioned herein are used solely for the purpose of illustration and Holtek makes no warranty or representation that such applications will be suitable without further modification, nor recommends the use of its products for application that may present a risk to human life due to malfunction or otherwise. Holtek's products are not authorized for use as critical components in life support devices or systems. Holtek reserves the right to alter its products without prior notification. For the most up-to-date information, please visit our web site at <http://www.holtek.com.tw>.