

Features

- Supply voltage range from 1.8V to 5.5V
- Supply Current: 50 μ A/amplifier - typical
- Rail-to-Rail Input/Output
- Gain Bandwidth: 550kHz - typical
- Available in Single, Dual and Quad versions
- Range of package types

Applications

- Automotive Applications
- Portable Equipment
- Photodiode Amplifiers
- Analog Filters
- Battery Powered Systems

Selection Table

Device	Op-Amps	Package
HT9251	Single	SOT23-5
HT9252	Dual	8DIP/SOP
HT9254	Quad	14DIP/SOP

General Description

The HT9251/HT9252/HT9254 family of operational amplifiers offer the benefits of operating with a single supply voltage as low as 1.8V and with a supply current of 50 μ A/amplifier. The devices also provide full rail-to-rail input and output operation. The device range has a gain bandwidth product of 550kHz and is unity gain stable. Available in single, dual and quad versions, along with a range of package types, this range of Low Voltage Operational Amplifiers will find excellent use in a wide range of applications for portable devices and battery powered equipment.

Block Diagram

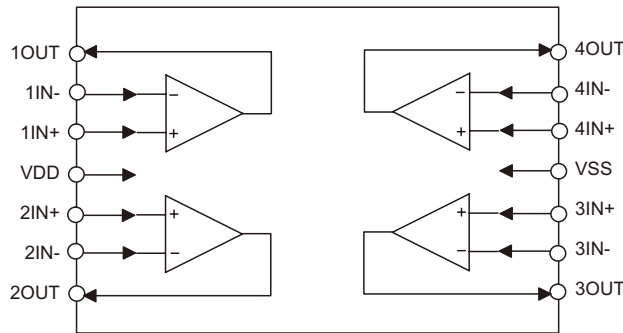

Pin Assignment

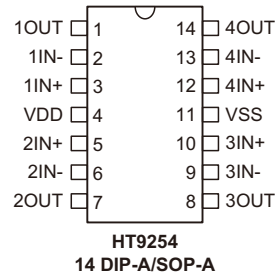
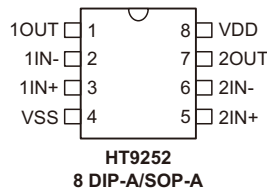
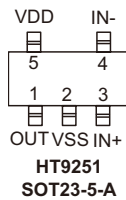

Pin Description

SOT23-5

Pin	Name	Pin Description
1	V_{OUT}	Analog Output
2	V_{SS}	Negative Power Supply
3	V_{IN+}	Non-inverting Input
4	V_{IN-}	Inverting Input
5	V_{DD}	Positive Power Supply

8DIP/SOP

Pin	Name	Pin Description
1	V_{1OUT}	Analog Output - op amp 1
2	V_{1IN-}	Inverting Input - op amp 1
3	V_{1IN+}	Non-inverting Input - op amp 1
4	V_{SS}	Negative Power Supply
5	V_{2IN+}	Non-inverting Input - op amp 2
6	V_{2IN-}	Inverting Input - op amp 2
7	V_{2OUT}	Analog Output - op amp 2
8	V_{DD}	Positive Power Supply

14DIP/SOP

Pin	Name	Pin Description
1	V_{1OUT}	Analog Output - op amp 1
2	V_{1IN-}	Inverting Input - op amp 1
3	V_{1IN+}	Non-inverting Input - op amp 1
4	V_{DD}	Positive Power Supply
5	V_{2IN+}	Non-inverting Input - op amp 2
6	V_{2IN-}	Inverting Input - op amp 2
7	V_{2OUT}	Analog Output - op amp 2
8	V_{3OUT}	Analog Output - op amp 3
9	V_{3IN-}	Inverting Input - op amp 3
10	V_{3IN+}	Non-inverting Input - op amp 3
11	V_{SS}	Negative Power Supply
12	V_{4IN+}	Non-inverting Input - op amp 4
13	V_{4IN-}	Inverting Input - op amp 4
14	V_{4OUT}	Analog Output - op amp 4

Absolute Maximum Ratings

Supply Voltage	6.0V	Storage Temperature	-65°C to 150°C
Input voltage range	$V_{SS}-0.3V$ to $V_{DD}+0.3V$	Operating Temperature	-40°C to 85°C
Differential Input Voltage	$\pm(V_{DD}-V_{SS})$	Junction Temperature.....	150°C
ESD protection - all pins (HBM;MM)	$\geq 4kV$; 200V		

Note: These are stress ratings only. Stresses exceeding the range specified under "Absolute Maximum Ratings" may cause substantial damage to the device. Functional operation of this device at other conditions beyond those listed in the specification is not implied and prolonged exposure to extreme conditions may affect device reliability.

Electrical Characteristics

Unless otherwise indicated, $V_{SS}=\text{GND}$, $T_A = 25^\circ\text{C}$, $V_{CM} = V_{DD}/2$, $V_{OUT} \approx V_{DD}/2$, $V_L = V_{DD}/2$, and $R_L = 100k\Omega$ to V_L , $C_L = 60pF$.

Symbol	Parameter	Test Conditions		Min.	Typ.	Max.	Unit
		V_{DD}	Conditions				
V_{DD}	Supply Voltage	—	—	1.8	—	5.5	V
V_{OS}	Input Offset Voltage	5V	$V_{CM}=0\sim 3V$	-6	—	+6	mV
$\Delta V_{OS}/\Delta T$	Temperature Drift	5V	$V_{IN}=V_{CM}/2$	—	± 2	—	$\mu V/^\circ\text{C}$
I_{OS}	Input Offset Current	5V	$T_A=25^\circ\text{C}$	—	± 5	—	pA
I_B	Input Bias Current	5V	$T_A=25^\circ\text{C}$	—	± 50	—	pA
V_{CM}	Input Common Mode Range	5V	$T_A=25^\circ\text{C}$	$V_{SS}+20$	—	$V_{DD}-20$	mV
V_{OH}, V_{OL}	Maximum Output Voltage Swing	5V	0.5V input overdrive $R_L=100k\Omega$ to V_L	$V_{SS}+35$	—	$V_{DD}-35$	mV
A_{OL}	DC Open-Loop Gain - Large Signal	5V	$V_{OUT}=35mV$ to $V_{DD}-35mV$ $V_{IN}=V_{CM}/2$	70	100	—	dB
GBW	Gain Bandwidth Product	5V	$R_L=10k\Omega$, $C_L=60pF$, $V_{IN}=V_{CM}/2$	—	550	—	kHz
Φ_m	Phase Margin	5V	$R_L=10k\Omega$, $C_L=60pF$ $G=+1V/V$, $V_{IN+} = V_{DD}/2$	—	68	—	Degree
CMRR	Common Mode Rejection Ratio	5V	$V_{CM} = V_{SS}+20mV$ to $V_{DD}-20mV$		75	—	dB
PSRR	Power Supply Rejection Ratio	5V	$V_{IN}=0.2V$	65	95	—	dB
I_{CC}	Supply Current per Single Amplifier	5V	$I_O=0A$	30	50	70	μA
SR	Slew Rate at Unity Gain	5V	$R_L=100k\Omega$, $C_L=60pF$	—	0.3	—	$V/\mu s$
I_{SC}	Output Short Circuit Current	1.8V	—		± 6	--	mA
		5.5V	—		± 23	--	mA

Application Circuit

Summing Amplifier Circuit

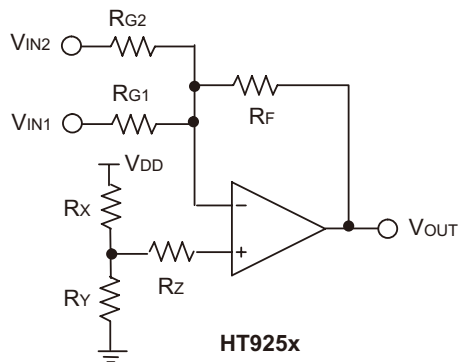

$$R_{VIN-} = \frac{1}{\left(\frac{1}{R_{G1}} + \frac{1}{R_{G2}} + \frac{1}{R_F}\right)}, \quad R_{VIN-} = \text{total resistance at the inverting input}$$

$$R_{VIN+} = \frac{1}{\left(\frac{1}{R_X} + \frac{1}{R_Y}\right)} + R_Z, \quad R_{VIN+} = \text{total resistance at the inverting input}, \quad R_{VIN+} = R_{VIN-}$$

Compensating Effect of Parasitic Capacitance at the Input

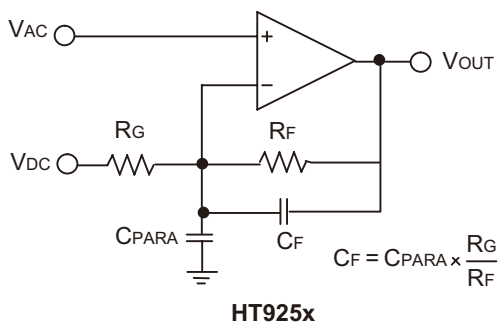

Typical Performance Characteristics

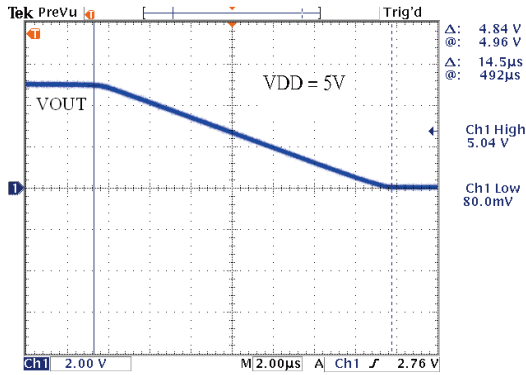

Fig 1. Maximum Output Voltage Swing

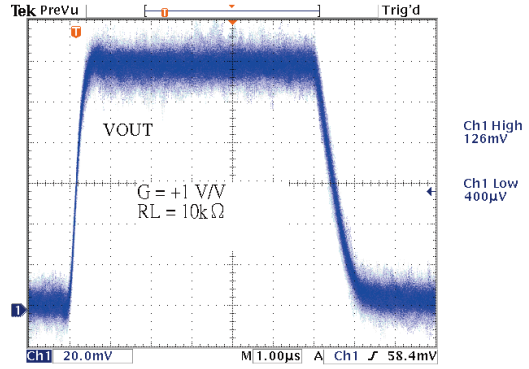

Fig 4. Small-Signal, Non-Inverting Pulse Response

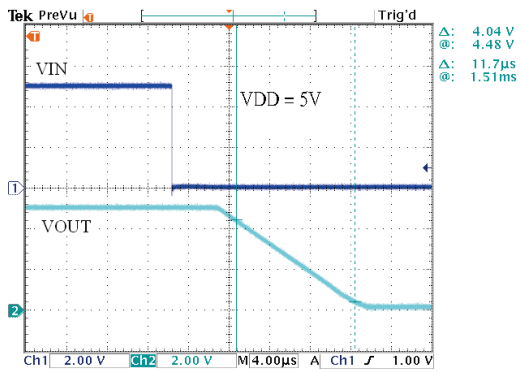

Fig 2. Slew Rate-Falling

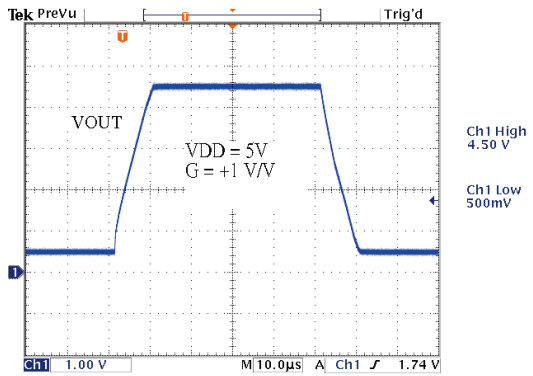

Fig 5. Large-Signal, Non-Inverting Pulse Response

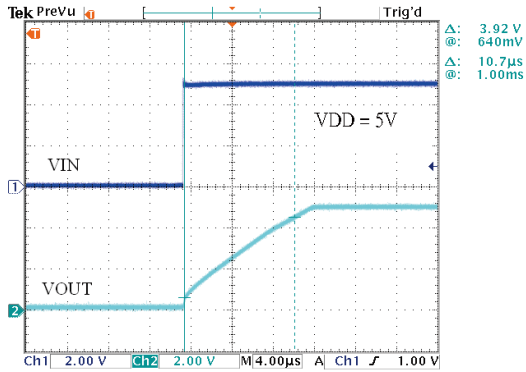

Fig 3. Slew Rate-Rising

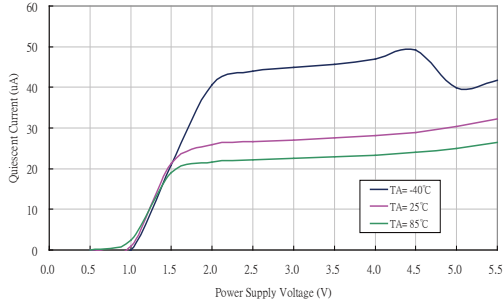

Fig 6. Quiescent Current vs. Power Supply Voltage

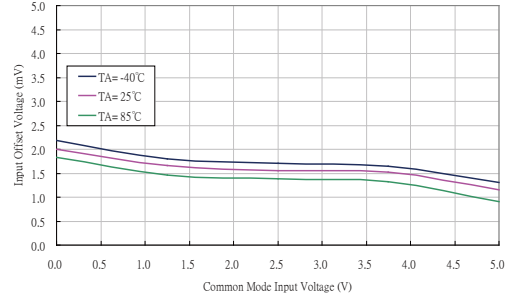

Fig 9. Input Offset Voltage vs. Common Mode Input Voltage at $V_{DD}=5.0V$

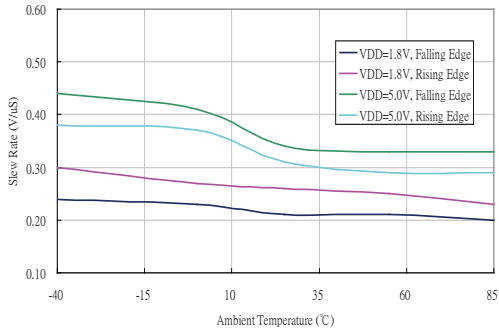

Fig 7. Slew Rate vs. Temperature

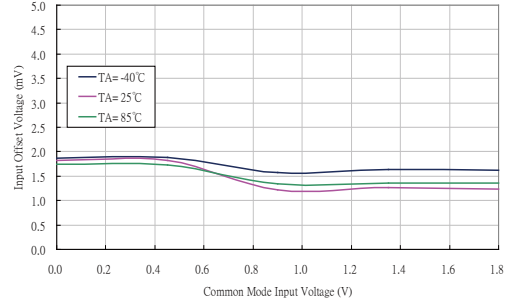

Fig 10. Input Offset Voltage vs. Common Mode Input Voltage at $V_{DD}=1.8V$

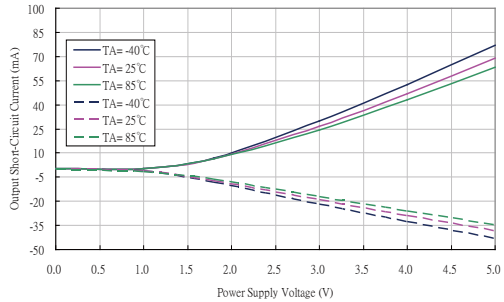
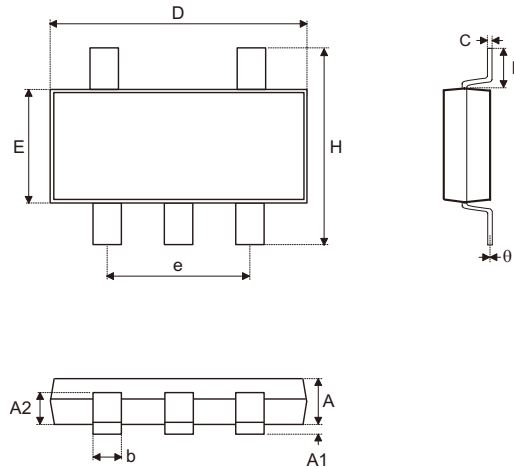

Fig 8. Output Short-Circuit Current vs. Power Supply Voltage

Package Information

Note that the package information provided here is for consultation purposes only. As this information may be updated at regular intervals users are reminded to consult the Holtek website (<http://www.holtek.com.tw/english/literature/package.pdf>) for the latest version of the package information.

5-pin SOT23-5 Outline Dimensions



Symbol	Dimensions in inch		
	Min.	Nom.	Max.
A	0.039	—	0.051
A1	—	—	0.004
A2	0.028	—	0.035
b	0.014	—	0.020
C	0.004	—	0.010
D	0.106	—	0.122
E	0.055	—	0.071
e	—	0.075	—
H	0.102	—	0.118
L	0.015	—	—
θ	0°	—	9°

Symbol	Dimensions in mm		
	Min.	Nom.	Max.
A	1.00	—	1.30
A1	—	—	0.10
A2	0.70	—	0.90
b	0.35	—	0.50
C	0.10	—	0.25
D	2.70	—	3.10
E	1.40	—	1.80
e	—	1.90	—
H	2.60	—	3.00
L	0.37	—	—
θ	0°	—	9°

8-pin DIP (300mil) Outline Dimensions

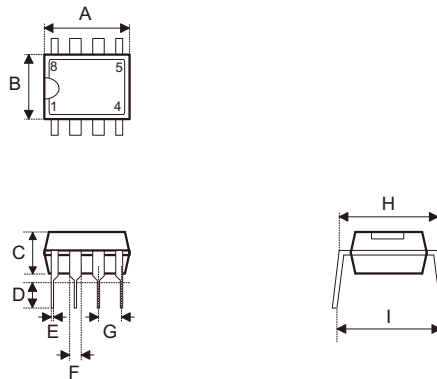

Symbol	Dimensions in inch		
	Min.	Nom.	Max.
A	0.355	—	0.375
B	0.240	—	0.260
C	0.125	—	0.135
D	0.125	—	0.145
E	0.016	—	0.020
F	0.050	—	0.070
G	—	0.100	—
H	0.295	—	0.315
I	—	0.375	—

Symbol	Dimensions in mm		
	Min.	Nom.	Max.
A	9.02	—	9.53
B	6.10	—	6.60
C	3.18	—	3.43
D	3.18	—	3.68
E	0.41	—	0.51
F	1.27	—	1.78
G	—	2.54	—
H	7.49	—	8.00
I	—	9.53	—

8-pin SOP (150mil) Outline Dimensions

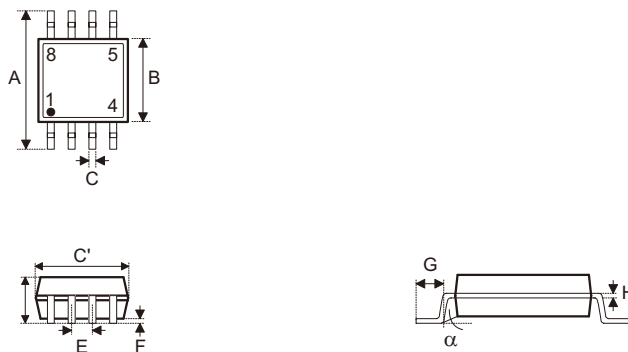

MS-012

Symbol	Dimensions in inch		
	Min.	Nom.	Max.
A	0.228	—	0.244
B	0.150	—	0.157
C	0.012	—	0.020
C'	0.188	—	0.197
D	—	—	0.069
E	—	0.050	—
F	0.004	—	0.010
G	0.016	—	0.050
H	0.007	—	0.010
α	0°	—	8°

Symbol	Dimensions in mm		
	Min.	Nom.	Max.
A	5.79	—	6.20
B	3.81	—	3.99
C	0.30	—	0.51
C'	4.78	—	5.00
D	—	—	1.75
E	—	1.27	—
F	0.10	—	0.25
G	0.41	—	1.27
H	0.18	—	0.25
α	0°	—	8°

14-pin DIP (300mil) Outline Dimensions

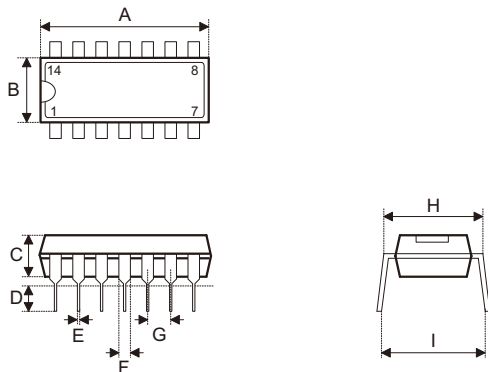

Symbol	Dimensions in inch		
	Min.	Nom.	Max.
A	0.745	—	0.775
B	0.240	—	0.260
C	0.125	—	0.135
D	0.125	—	0.145
E	0.016	—	0.020
F	0.050	—	0.070
G	—	0.110	—
H	0.295	—	0.315
I	—	0.375	—

Symbol	Dimensions in mm		
	Min.	Nom.	Max.
A	18.92	—	19.69
B	6.10	—	6.60
C	3.18	—	3.43
D	3.18	—	3.68
E	0.41	—	0.51
F	1.27	—	1.78
G	—	2.54	—
H	7.49	—	8.00
I	—	9.53	—

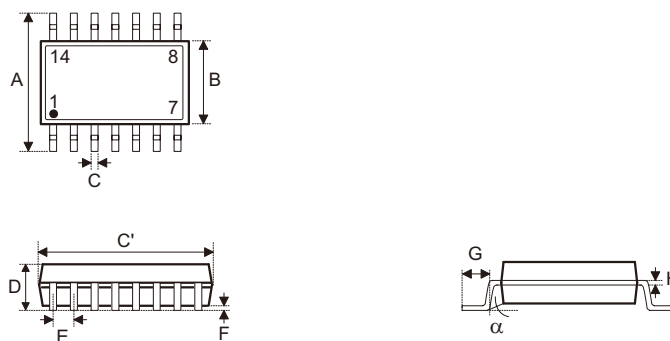
14-pin SOP (150mil) Outline Dimensions

MS-012

Symbol	Dimensions in inch		
	Min.	Nom.	Max.
A	0.228	—	0.244
B	0.150	—	0.157
C	0.012	—	0.020
C'	0.337	—	0.334
D	—	—	0.069
E	—	0.050	—
F	0.004	—	0.010
G	0.016	—	0.050
H	0.007	—	0.010
α	0°	—	8°

Symbol	Dimensions in mm		
	Min.	Nom.	Max.
A	5.79	—	6.20
B	3.81	—	3.99
C	0.30	—	0.51
C'	8.56	—	8.74
D	—	—	1.75
E	—	1.27	—
F	0.10	—	0.25
G	0.41	—	1.27
H	0.18	—	0.25
α	0°	—	8°

Product Tape and Reel Specifications

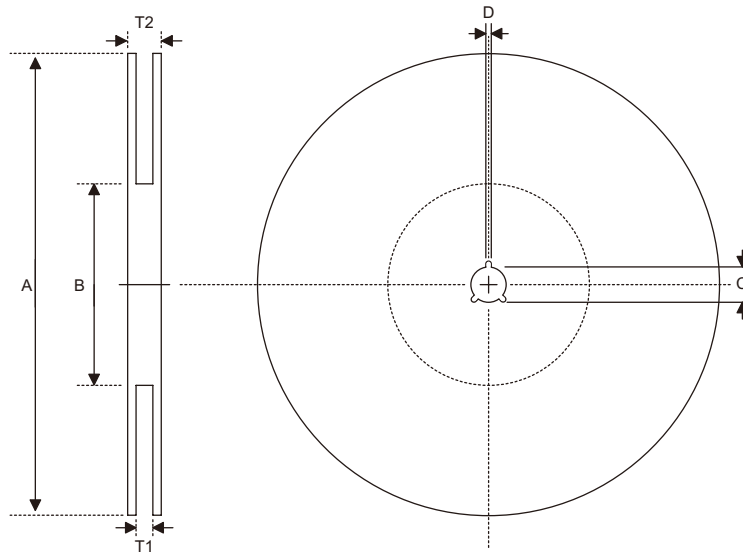
Reel Dimensions



SOP 8N

Symbol	Description	Dimensions in mm
A	Reel Outer Diameter	330.0±1.0
B	Reel Inner Diameter	100.0±1.5
C	Spindle Hole Diameter	13.0 ^{+0.5/-0.2}
D	Key Slit Width	2.0±0.5
T1	Space Between Flange	12.8 ^{+0.3/-0.2}
T2	Reel Thickness	18.2±0.2

SOP 14N

Symbol	Description	Dimensions in mm
A	Reel Outer Diameter	330.0±1.0
B	Reel Inner Diameter	100.0±1.5
C	Spindle Hole Diameter	13.0 ^{+0.5/-0.2}
D	Key Slit Width	2.0±0.5
T1	Space Between Flange	16.8 ^{+0.3/-0.2}
T2	Reel Thickness	22.2±0.2

SOT23-5

Symbol	Description	Dimensions in mm
A	Reel Outer Diameter	178.0±1.0
B	Reel Inner Diameter	62.0±1.0
C	Spindle Hole Diameter	13.0±0.2
D	Key Slit Width	2.50±0.25
T1	Space Between Flange	8.4 ^{+1.5/-0.0}
T2	Reel Thickness	11.4 ^{+1.5/-0.0}

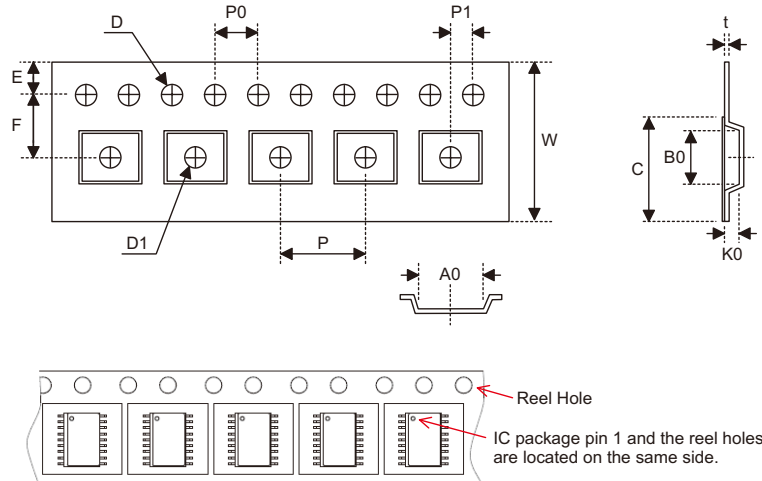
Carrier Tape Dimensions

SOP 8N

Symbol	Description	Dimensions in mm
W	Carrier Tape Width	12.0 ^{+0.3/-0.1}
P	Cavity Pitch	8.0±0.1
E	Perforation Position	1.75±0.10
F	Cavity to Perforation (Width Direction)	5.5±0.1
D	Perforation Diameter	1.55±0.1
D1	Cavity Hole Diameter	1.50 ^{+0.25/-0.00}
P0	Perforation Pitch	4.0±0.1
P1	Cavity to Perforation (Length Direction)	2.0±0.1
A0	Cavity Length	6.4±0.1
B0	Cavity Width	5.2±0.1
K0	Cavity Depth	2.1±0.1
t	Carrier Tape Thickness	0.30±0.05
C	Cover Tape Width	9.3±0.1

SOP 14N

Symbol	Description	Dimensions in mm
W	Carrier Tape Width	16.0 ^{+0.3/-0.1}
P	Cavity Pitch	8.0±0.1
E	Perforation Position	1.75±0.10
F	Cavity to Perforation (Width Direction)	7.5±0.1
D	Perforation Diameter	1.5 ^{+0.1/-0.0}
D1	Cavity Hole Diameter	1.50 ^{+0.25/-0.00}
P0	Perforation Pitch	4.0±0.1
P1	Cavity to Perforation (Length Direction)	2.0±0.1
A0	Cavity Length	6.5±0.1
B0	Cavity Width	9.5±0.1
K0	Cavity Depth	2.1±0.1
t	Carrier Tape Thickness	0.30±0.05
C	Cover Tape Width	13.3±0.1

SOT23-5

Symbol	Description	Dimensions in mm
W	Carrier Tape Width	8.0±0.3
P	Cavity Pitch	4.0±0.1
E	Perforation Position	1.75±0.10
F	Cavity to Perforation (Width Direction)	3.50±0.05
D	Perforation Diameter	1.5 ^{+0.1/-0.0}
D1	Cavity Hole Diameter	1.5 ^{+0.1/-0.0}
P0	Perforation Pitch	4.0±0.1
P1	Cavity to Perforation (Length Direction)	2.00±0.05
A0	Cavity Length	3.15±0.10
B0	Cavity Width	3.2±0.1
K0	Cavity Depth	1.4±0.1
t	Carrier Tape Thickness	0.20±0.03
C	Cover Tape Width	5.3±0.1

Holtek Semiconductor Inc. (Headquarters)

No.3, Creation Rd. II, Science Park, Hsinchu, Taiwan
Tel: 886-3-563-1999
Fax: 886-3-563-1189
<http://www.holtek.com.tw>

Holtek Semiconductor Inc. (Taipei Sales Office)

4F-2, No. 3-2, YuanQu St., Nankang Software Park, Taipei 115, Taiwan
Tel: 886-2-2655-7070
Fax: 886-2-2655-7373
Fax: 886-2-2655-7383 (International sales hotline)

Holtek Semiconductor (China) Inc.

Building No. 10, Xinzhu Court, (No. 1 Headquarters), 4 Cuizhu Road, Songshan Lake, Dongguan, China 523808
Tel: 86-769-2626-1300
Fax: 86-769-2626-1311

Holtek Semiconductor (USA), Inc. (North America Sales Office)

46729 Fremont Blvd., Fremont, CA 94538, USA
Tel: 1-510-252-9880
Fax: 1-510-252-9885
<http://www.holtek.com>

Copyright© 2012 by HOLTEK SEMICONDUCTOR INC.

The information appearing in this Data Sheet is believed to be accurate at the time of publication. However, Holtek assumes no responsibility arising from the use of the specifications described. The applications mentioned herein are used solely for the purpose of illustration and Holtek makes no warranty or representation that such applications will be suitable without further modification, nor recommends the use of its products for application that may present a risk to human life due to malfunction or otherwise. Holtek's products are not authorized for use as critical components in life support devices or systems. Holtek reserves the right to alter its products without prior notification. For the most up-to-date information, please visit our web site at <http://www.holtek.com.tw>.