

Features

- Input supply AC voltage range: 100V~240V
- Ultra low power-on start-up current < 30 μ A
- Integrated 25V Zener diode internally connected to VIN pin
- 5V LDO output voltage with 6mA driving current for external components
- Frequency jitter function for enhanced EMI performance
- Efficiency > 85%
- Under Voltage Lockout function – UVLO
- Current mode operation with cycle-by-cycle current limiting
- Over temperature protection function
- High-current FET drive output
- Linear and PWM dimming function
- Enhanced short circuit protection function

Applications

- AC/DC and DC/DC power control for high power LED lighting
- RGB back lighting LED driver
- Flat panel displays back lighting
- General purpose constant current source
- Signage and decorative LED lighting
- Battery chargers

General Description

The HT7L4091 device provides a low-cost solution for active current mode PWM controls of High Intensity LED drive systems supplied by either AC or DC line power lines. The device operates in constant off-time mode which is suitable for buck LED drivers. The low start-up and operating currents provides flexible power requirements for high efficiency or low cost applications. The switch frequency off-time can be programmed using an external resistor. The peak current mode control achieves good output current regulation without requiring loop compensations for a wide range of input voltages.

Included in the device is a PWM dimming input which can accept an external control signal with a duty ratio from 0 to 100%. The output current can be programmed from 0 to 250mA by applying an external control voltage on the linear dimming control input.

The device includes a frequency jitter function which helps to reduce EMI power supply emissions. Also contained is an enhanced LED short circuit protection feature to protect the internal circuitry from damage should the LEDs be short circuited.

The device requires a minimum number of external standard components and is available in an 8-pin SOP package for small area PCB applications.

Ordering Information

Part Number	Function Description
HT7L4091	Frequency jitter function enabled, $V_{UVLO(H)}=16V$ (typ.)
HT7L4091-1	Frequency jitter function disabled, $V_{UVLO(L)}=8V$ (typ.)

Block Diagram

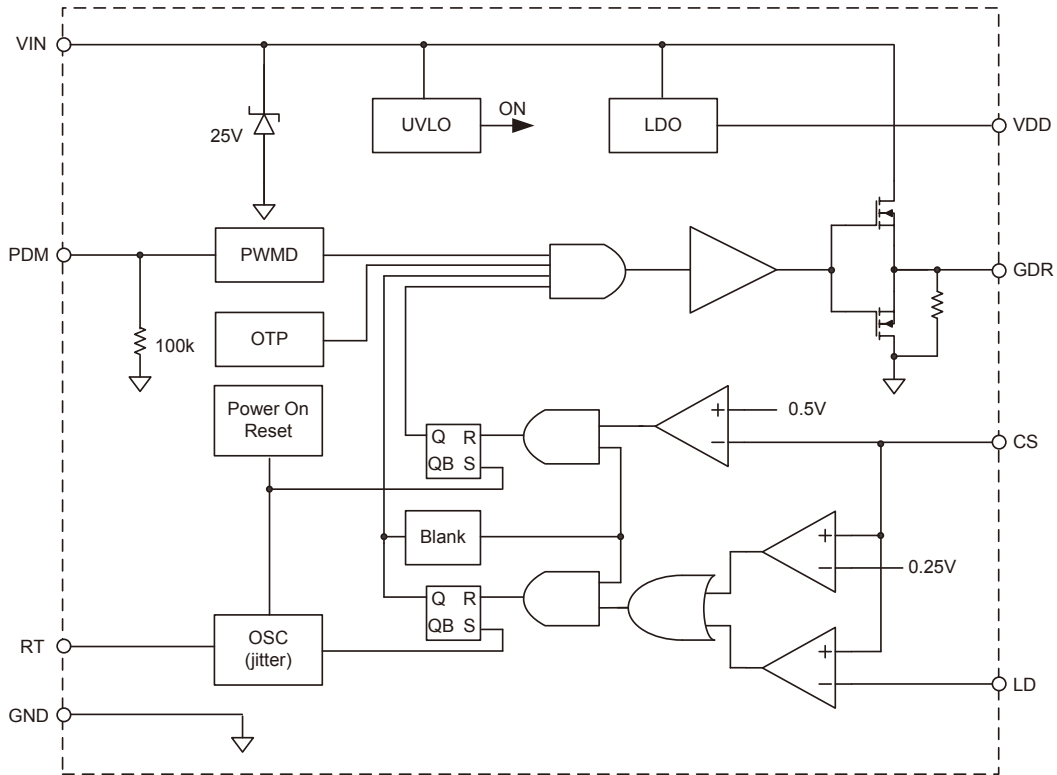

Pin Assignment

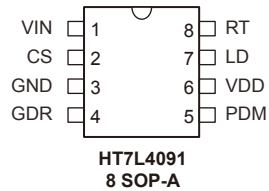

Pin Description

Pin Name	I/O	Description
VIN	I	Input voltage pin
CS	I	LED string current sense input
GND	—	Power ground
GDR	O	Gate driver for the external MOSFET
PDM	I	PWM dimming pin Also functions as enable input pin.
VDD	O	Positive Power supply Used for the internal circuits except the gate driver circuit. A 0.1 μ F capacitor must be connected between the VDD and the GND pins.
LD	I	Linear dimming pin Set the current sense threshold as long as the voltage on this pin is less than 250mV (typ.).
RT	I	Oscillator control pin A resistor is connected between the RT and the GND pins to set the off-time.

Absolute Maximum Ratings

Output Current Peak	1A	Thermal Resistance, SOP-8 θ_{JA}	150°C/W
Storage Temperature Range	-65°C ~ +150°C	ESD Voltage Protection, Human Body Model.....	6KV
Junction Temperature Range.....	-40°C ~ +150°C	ESD Voltage Protection, Machine Model.....	400V
CS, P _{DM} , LD ,RT, to GND.....	-0.3V to (V _{DD} +0.3V)		
Power Dissipation at Ta<25°C.....	0.6W		

Note: These are stress ratings only. Stresses exceeding the range specified under “Absolute Maximum Ratings” may cause substantial damage to the device. Functional operation of this device at other conditions beyond those listed in the specification is not implied and prolonged exposure to extreme conditions may affect device reliability.

Recommended Operating Ranges

Input Supply Voltage.....	V _{UVLO(H)} +0.1V~V _{CLAMP}	Operating Temperature Range	-40°C ~ +105°C
---------------------------	---	-----------------------------------	----------------

Note 1: Absolute maximum ratings indicate limits beyond which damage to the device may occur. Operating Ratings indicate conditions for which the device is intended to be functional, but do not guarantee specific performance limits. The guaranteed specifications apply only for the test conditions listed.

Note 2: The power supply pin should not be driven by a DC, low impedance power source greater than the V_{CLAMP} voltage specified in the Electrical Characteristics section.

Electrical Characteristics

(V_{IN}=17V, Ta=25°C, unless otherwise specified)

Symbol	Description	Test Condition	Min.	Typ.	Max.	Unit
Input						
V _{INDC}	Input DC supply voltage	—	8.5	—	V _{Clamp}	V
I _{IN}	Input Operation Current	V _{INDC} ≥17V, R _T =410kΩ GDR pin floating	—	0.6	1	mA
I _{INST}	Startup Input current	V _{INDC} <15V, R _T =410kΩ	—	15	30	μA
V _{CLAMP}	V _{IN} Clamp Voltage	I _{IN} =10mA	22.4	25	27.6	V
Internal Regulator						
V _{DD}	Internally regulated voltage	V _{INDC} =12V~26V	4.5	5	5.5	V
ΔV _{DD, line}	Line regulation of V _{DD}	V _{INDC} =12V~26V, I _{DD} =0mA	0	—	100	mV
ΔV _{DD, load}	Load regulation of V _{DD}	V _{INDC} =17V, I _{DD} =0mA~3mA	0	—	100	mV
V _{UVLO(H)}	V _{INDC} under voltage lockout high threshold	V _{INDC} rising for HT7L491	15	16	17	V
		V _{INDC} rising for HT7L491-1	7.5	8.0	8.5	V
V _{UVLO(L)}	V _{INDC} under voltage lockout low threshold	V _{INDC} falling for HT7L491	9	10	11	V
		V _{INDC} falling for HT7L491-1	6.7	7.2	7.7	V
V _{EN(L)}	Input low voltage for PDM pin	V _{INDC} =12V~26V	—	—	0.8	V
V _{EN(H)}	Input high voltage for PDM pin	V _{INDC} =12V~26V	2.0	—	—	V
R _{EN}	PDM pin Pull-low resistor	—	50	100	150	kΩ
V _{CS(TH)}	Current sense trip threshold voltage	—	0.24	0.248	0.255	V

Symbol	Description	Test Condition	Min.	Typ.	Max.	Unit
T _{delay}	Delay from CS trip to GDR	V _{CS} =V _{CS_TH} +50mV	—	110	—	ns
V _{LD}	Linear Dimming pin voltage range	—	0	—	V _{CS_TH}	V
T _{blank}	Blanking interval	—	200	300	400	ns
T _{off}	Off time	R _T =410kΩ	14.7	16.4	18.1	μs
V _{OL}	GATE Output Low Level	V _{INDC} =17V, I _o =-20mA	—	—	0.3	V
V _{OH}	GATE Output High Level	V _{INDC} =17V, I _o =20mA	12	—	—	V
T _{rise}	Gate output rise time	C _{GATE} =500pF	—	120	—	ns
T _{fall}	Gate output fall time	C _{GATE} =500pF	—	50	—	ns
T _{OTP}	Thermal shutdown temperature	—	—	140	—	—
ΔT _{OTP}	Thermal shutdown temperature hysteresis	—	—	25	—	—
Δf _{Jitter}	Switch frequency jitter ratio	—	—	±4	—	%
T _{JP}	Jitter Period	f _{sw} = 60kHz	—	4	—	ms
V _{CS-short}	Short circuit protection Voltage	—	0.45	0.5	0.55	V

Note 3: Specifications are production tested at TA=room temperature. Specifications over the -40°C to 85°C operating temperature range are assured by design, characterization and correlation with Statistical Quality Controls (SQC).

Functional Description

The HT7L4091 is a universal AC/DC constant current LED driver designed for peak current mode control. The device provides both LED Linear and PWM dimming current functions. The high input voltage from a rectified 85V to 260V AC power is clamped to under 25V by an external circuit and an internal Zener diode. The device also contains an input Under-Voltage-Lockout (UVLO) circuit. When the voltage supplied on the VIN pin exceeds the UVLO high threshold, the gate driver is enabled. If the input voltage falls below the UVLO low threshold, the gate driver is turned off.

LED Current Control

The HT7L4091 device is a constant off-time peak current mode controller. With reference to the Application Circuit, the LED peak current is programmed by an external current sense resistor (R_{CS}) connected between the CS and the ground pins. The CS pin is connected to a non-inverting terminal of an internal comparator of which an internal 250mV reference is tied to the inverting terminal. The LED peak current through the R_{CS} resistor will generate a voltage which is applied on the comparator non-inverting terminal and compare with the internal 250mV reference voltage. If the voltage on the CS pin is less than the internal reference voltage 250mV, the

LED gate driving circuitry will be turned on. While the voltage on the CS pin is larger than the internal reference voltage, the LED gate driving circuitry will be turned off for a constant T_{off} time. After the T_{off} time, the gate driving circuitry will be turned on if the voltage on the CS pin is less than the internal reference voltage. Good line regulation is a feature of constant off-time operation and the LED current is independent of the input voltage. Since the inductor current ripple is dependent on the LED string voltage, the LED string voltage variation will result in LED current variation. This is typically not a problem since the LED voltage variation for a given load is fairly small.

R_{CS} can be calculated using the following equation:

$$R_{CS} = \frac{0.25}{I_{peak}} = \frac{0.25}{(1 + 1/2 \times \text{Ripple}) \cdot I_{LED}}$$

Where I_{peak} is the Maximum LED Current, Ripple is the Peak to Peak LED Current, and I_{LED} is the Average LED Current. Ripple can be controlled by the inductor. 0

$$I_{LED} \times \text{Ripple} = I_{Ripple} = \frac{T_{off} \times V_{out}}{L}$$

Refer to “Inductor Design” for the inductor calculation. Refer to “Programmable Off Time” for T_{off} calculation.

Programmable Off Time

The device operates in a constant off-time mode. A resistor connected between the RT pin and the ground pin generates a constant current source which is used to charge an internal capacitor and determine the off-time. Increasing the resistance reduces the amplitude of the current source and increases the off-time. The relationship between the resistor R_T and the off-time is given by the following formula:

$$T_{off} = C_T \times R_T \quad C_T = 36\text{pF} \sim 44\text{pF}, C_{T_typ} = 40\text{pF}$$

For a given T_{off} and duty cycle, the switching frequency (f_s) can be decided. The duty cycle is determined by the input and output voltages.

Current Sense

The current sense input is connected to the non-inverting inputs of two comparators. The inverting terminal of one comparator is tied to an internal 250mV reference whereas the other comparator inverting terminal is connected to the LD pin. The outputs of both these comparators are fed into an OR gate and the output of the OR gate is fed into the reset pin of a flip-flop. If a flip-flop reset event is triggered by the OR gate output a signal occurs where the external MOSFET gate driving circuitry will be turned off. Therefore, the comparator which has the lower voltage at the inverting terminal determines when the gate driving output is turned off.

Leading-Edge Blanking

Each time the power MOSFET is switched on, a turn-on transient spike will occur on the CS pin. To avoid premature termination of the switching pulse, a T_{Blank} leading-edge blank time is generated during the MOSFET switch turn-on to prevent false triggering of the current sense comparator. During this blanking period, the current-limit comparator is disabled and the gate driving circuitry will not be switched off.

In certain rare situations, the internal blanking time might not be long enough to filter out the turn-on spike. In such situations, it will be necessary to add an external RC filter between the external sense resistor (R_{CS}) and the CS pin.

Frequency Jitter Function

The device also includes a frequency jitter function. The frequency has a variation range of +4% to -4% within four milliseconds. The frequency jitter function helps reduce power supply line EMI emissions with minimum line filters.

Input Supply Current

The input supply current is determined by the input operating current and the current drawn by the external MOSFET gate driver. This means that the input supply current depends upon the switching frequency and the external MOSFET gate charge.

$$I_{INSP} = I_{IN} + Q_{gate} \times f_s$$

In addition, where I_{INSP} is the input supply current taken from the VIN pin, f_s is the switching frequency Q_{gate} is the gate charge of the external MOSFET and I_{IN} is the input operation current.

The application circuit should provide enough I_{INSP} to ensure the application can work properly

Start-up Current and Auxiliary Power Source

The power consumption of the HT7L4091 is one of the major efficiency losses if I_{INSP} drops from the rectified AC source whose voltage is much higher than the voltage used by the device. For efficiency improvements, a small start-up current from the rectified AC source is used to start up the HT7L4091 and I_{INSP} can be provided from the auxiliary power source, for example: auxiliary winding.

The start-up current should take into consideration the C_{in} (V_{in} Capacitor) charge current and the current consumption of the HT7L4091 during start-up (I_{inst}). The C_{in} charge current shall consider how fast ($t_{start-up}$) the application is required to start operation. The start-up current can be calculated using the follow equation:

$$I_{start-up} = I_{inst} + \frac{C_{in} \times V_{UVLO(H)}}{t_{start-up}}$$

The current from auxiliary power source should be:

$$I_{aux} = I_{INSP} - I_{start-up}$$

The start-up current allows a start-up resistor with a high resistance and a low-power rating. The start-up resistor (R_{INST}) is used to supply the start-up power for the device from the rectified AC source. R_{INST} can be calculated using the following equation:

$$R_{INST} = \frac{\sqrt{2} \cdot V_{min, AC} - V_{UVLO(H)}}{I_{start-up}}$$

Linear Dimming

The Linear Dimming pin is used to control the LED current. The VDD pin voltage can be connected to the LD pin to obtain a voltage corresponding to the desired voltage across R_{CS} . The LD pin can adjust the current level to reduce the illumination intensity of the LEDs. To adjust the external LD pin voltage from 0mV to 250mV can adjust the LED current during operation. To use the internal 250mV as the reference voltage, the LD pin can be connected to VDD.

PWM Dimming

An external enable input named PDM is provided and can be utilized for PWM dimming of the LED string. When the external PWM signal is zero, the gate driving circuitry is turned off while the gate driving circuits are turned on when the PWM signal is high.

LED Open and Short Circuit Protection

There will be no abnormal behavior if the LEDs are open circuit. While some LEDs are shorted, the output voltage will be adjusted automatically for the condition.

Enhanced Short Circuit Protection

When most LEDs are shorted in the application circuit, the current regulation may lose control resulting in the current increasing to an extremely high level. When the current is more than twice of the set I_{peak} , resulting from externally shorted LEDs, the device will shut down gate driving operations.

The operation state is shown in the accompanying figure. When the circuit is operating normally, V_{CS} can be limited to V_{CS-TH} , while some LEDs are shorted, the LED current is still limited and the output voltage is adjusted to meet the current requirement. If the circuit encounters a serious short, the voltage increase of (current) in T_{Blank} would be larger than the decrease in T_{OFF} , V_{CS} will exceed V_{CS-TH} and reach $V_{CS-Short}$. The HT7L4091 will then shut down the gate driver until UVLO resets the HT7L4091.

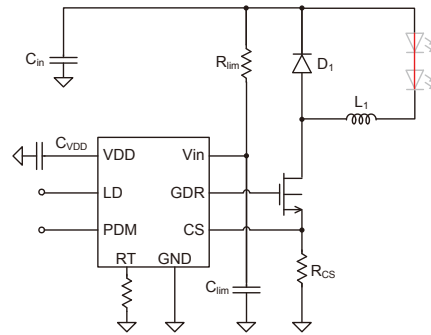
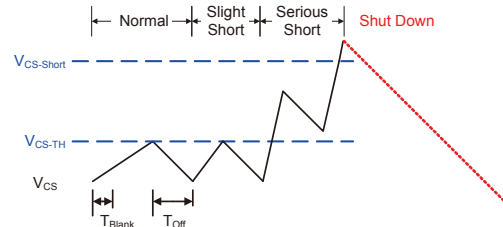

Application Description

This section shows how to design a buck circuit LED application using a simple example. For other application conditions, such as high efficiency solutions, refer to the HT7L4091 application notes for more details.

For example:

AC Input voltage: $V_{AC_typ} = 110V_{rms}$; $V_{AC_min} = 95V_{rms}$; $V_{AC_max} = 125V_{rms}$; $f_{AC} = 60Hz$

Target working condition: $F_{PWM} > 40kHz$

Output Voltage: LED string \times LED Voltage = $8 \times (3 \sim 3.3)$ = 24V~26.4V, typical 25.2V

Average Output LED Current: $I_{LED} = 400mA$

Expected efficiency: $\eta = 90\%$

Refer to the typical application circuit.

Input Bulk Capacitor – C1

The input Bulk Capacitor determines the ripple amplitude of input voltage after rectification. A large capacitance generates a smaller input voltage ripple amplitude. The first design criterion to meet is that the maximum LED string voltage should be less than 80% of the minimum AC input voltage ($V_{min,AC}$). Note that 80% is a rough estimate here. Here the large ripple amplitude has a wide frequency variation which leads to increase in circuit power losses. Assume that the input voltage DC ripple ($\Delta V_{DCripple\%}$) is equal to 30% and then calculate the C1 value.

$$\begin{aligned} & \sqrt{2} \times V_{AC_min} \times (1 - \Delta V_{DCripple\%}) \times 0.8 \\ &= \sqrt{2} \times 95 \times (1 - 30\%) \times 0.8 \\ &= 75.2V > 26.4V \text{ (maximum output voltage)} \end{aligned}$$

Above formula means 30% input voltage ripple is approved that exceed output voltage.

Finally, a useful rule can find the valley voltage of the input voltage. Using the figure below, it is necessary to calculate the charge time and discharge time of the input bulk capacitor.

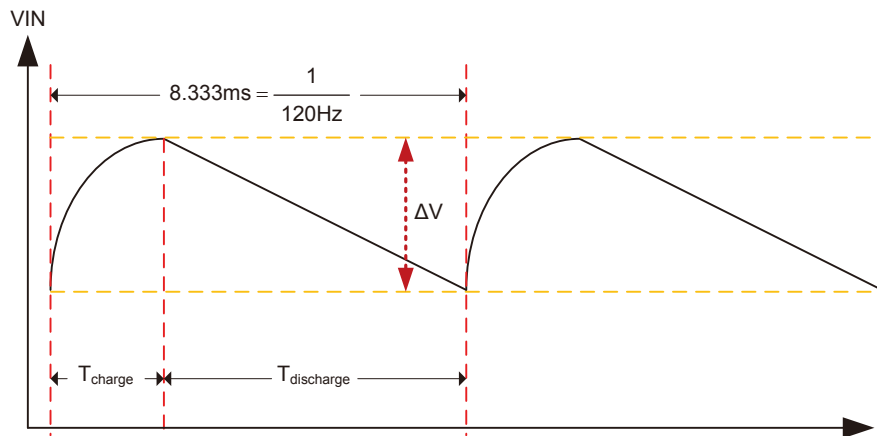

The Waveform of Input Voltage in the C1

$$\text{Charge period: } T_{CP} = \frac{1}{2 \times f_{AC}} = 8.333ms$$

$$T_{charge} = \frac{T_{CP}}{2} \times \left[1 - \frac{\sin^{-1}\left(1 - \frac{\Delta V}{V_{IN}}\right)}{90} \right], \text{ where } \frac{\Delta V}{V_{IN}} = \Delta V_{DCripple\%}$$

$$T_{discharge} = T_{CP} - T_{charge}$$

$$T_{discharge} = 8.333ms - \frac{8.333ms}{2} \times \left[1 - \frac{\sin^{-1}(1 - 30\%)}{90} \right] = 6.2232ms$$

Then, the minimum capacitor value can be calculated as:

$$C1 \geq \frac{(2 \times n \times V_{LED_max} \times I_{LED}) \times T_{discharge}}{\eta \times \left[(\sqrt{2} \times V_{AC_min})^2 - (V_{DC_min})^2 \right]}$$

$$= \frac{(2 \times 8 \times 3.3V \times 400mA) \times 6.2232ms}{0.9 \times \left[(\sqrt{2} \times 95)^2 - (\sqrt{2} \times 95 \times 0.7)^2 \right]} = 15.9\mu F$$

Choose C1=22μF

Considering ±20% capacitance variation, the worst case lower value of the capacitance is 17.6μF, which is much larger than 14.3μF. It can be calculated that the input DC ripple is 24.5% when the input Buck capacitor is 17.6μF.

Therefore, if the real capacitor value is less than the calculated value, the voltage ripple will exceed the maximum range of 30% which is the specified assumption in the calculation.

Switching Frequency and Duty Cycle

Frequency interference should be taken into account to minimise interference with other electrical appliances. Here set the minimum switching frequency to a value of 40kHz for safety. If EMI suppression is good, the switching frequency can be decreased to 30kHz to obtain better efficiency.

Since the HT7L4091 operates in constant off time, the switching frequency would be changed by the input and output voltage. The slowest switching frequency occurs when the duty cycle is at a maximum value.

The maximum duty cycle can be calculated as,

$$D_{max} = \frac{V_{O_max}}{V_{DC_min}} = \frac{n \cdot V_{LED_max} + V_{F_DI}}{\sqrt{2} \cdot V_{AC_min} - (1 - V_{ripple})}$$

$$= \frac{3.3 \times 8 + 1.3}{\sqrt{2} \times 95 \times (1 - 24.5\%)} = 0.2731$$

Turn-off Time

$$T_{off} = \frac{1 - D_{max}}{f_{PWM_min}} = \frac{1 - 0.2731}{40k} = 18.173\mu s$$

Off-time Resistor – R_T

A resistor connected to the R_T pin determines the off-time which has a variation range from -10% to +10%. Since the working frequency has a minimum target, the C_T is considered to calculate the R_T:

$$T_{off} = C_T \times R_T \rightarrow R_T \leq \frac{18.173\mu s}{44pF} = 413.03k\Omega$$

Choose 390kΩ and 13kΩ for R_T are used

The off time is:

$$T_{off_typ} = C_{T_typ} \times R_T = 40p \times 403K = 16.1\mu s$$

$$T_{off_max} = C_{T_max} \times R_T = 44p \times 403K = 17.7\mu s$$

$$T_{off_min} = C_{T_min} \times R_T = 36p \times 403K = 14.5\mu s$$

The actual minimum frequency can be calculated as:

$$f_{PWM_min} = \frac{1 - D_{max}}{T_{off_max}} = \frac{1 - 0.2731}{17.7\mu} = 41.07K$$

f_{PWM_TYP@Vac_min} = 45.2kHz, f_{PWM_MAX@Vac_min} = 50.1kHz

Inductor Design

The ripple current is selected to be 30% of the nominal LED current. If the LED average current I_{LED} is 400mA, the LED string Voltage = n × V_{LED_max} = 8 × 3.3V where V_{LED_max} is the LED maximum forward voltage, then the inductor can be calculated by the following formula.

$$L = \frac{T_{off} \times n \times V_{LED_max}}{I_{LED} \times Ripple} = \frac{17.7\mu s \times 8 \times 3.3}{400mA \times 0.3} = 3.894mH$$

Choose L=3.8 mH

Current Sense Resistor – R_{CS}

This current flows through the external sense resistor R_{CS} and produces a ramp voltage on the CS pin. The comparators are constantly comparing the CS pin voltage with both the voltage on the LD pin and the internal 250mV reference voltage. Once the blanking time has elapsed, the output of these comparators can then reset the flip flop. When one output of these two comparators switches high, the flip flop is reset and the gate drive output switches low. The gate drive output stays low until the SR flip flop is set by the oscillator. In assuming a 30% ripple in the inductor, the current sense resistor R_{CS} can be obtained using the following formula:

$$R_{CS} = \frac{0.25}{I_{peak}} = \frac{0.25}{(1+1/2 \times \text{Ripple}) \cdot I_{LEDavg}}$$

$$= \frac{0.25}{(1+0.5 \times 0.3) \times 400mA} = 0.543\Omega$$

Choose R_{CS} = 0.54Ω

Input Supply Current

Assume that the input current drawn by the internal circuit from the VIN pin is the sum of the current with a value of 1.0mA and the current drawn by the gate driver of the external MOSFET (which in turn depends upon the switching frequency and the gate charge of the external FET). Assume that the gate charge Q_{gate} is equal to 12nC.

$$I_{INSP} = I_{IN} + Q_{gate} \times F_{PWM}$$

$$= 1mA + 12nC \times 50kHz = 1.6mA$$

In addition, where I_{INSP} is the input current taken from the VIN pin, F_{PWM} is the switching frequency, Q_{gate} is the gate charge of the external FET and I_{IN} is the current taken by the internal circuit. F_{PWM} is considered about the minimum input voltage and C_T has a minimum value.

Input Limit Resistor (R_{IN})

In this design, V_{AC_min} = 95V_{rms}, V_{UVLO(H)_max} = 17V

$$R_{in} = \frac{\sqrt{2} \cdot V_{AC_min} \times (1 - \Delta V_{DCripple\%}) - V_{UVLO(H)_max}}{I_{INSP}}$$

$$= \frac{\sqrt{2} \times 95 \times (1 - 30\%) - 17}{1.6mA} = 48.1k\Omega$$

Choose Rin=60kΩ

The input limit resistor consider the high input voltage from the rectified clamp voltage of the internal Zener diode and operating current. Two 30kΩ/1W resistors are used for Rin.

Output Capacitor – C_O

The capacitor, C_O, filters the current through the LEDs thus limiting the peak current of the LED string. Increasing the inductor ripple current corresponds to decreasing the inductor value and inductor size. In order to reduce the inductor value and size and obtain a smaller LED current ripple, the addition of a capacitor C_O is a good way to do this. Usually, a several μF output capacitor is added in practical application circuits.

Adding C_O connected across the LED strings can reduce the LED current ripple and while increasing the inductor current ripple variation can decrease the inductor value and size.

To assume inductor current ripple is 80%, a smaller inductor value could be calculated.

$$L = \frac{T_{off} \times n \times V_{LED_max}}{I_{LED} \times \text{Ripple}} = \frac{17.7\mu s \times 8 \times 3.3}{400mA \times 0.8} = 1.460mH$$

Choose L=1.4mH and C_O=1μF

The actual values of C_O and R_{CS} may need to be adjusted to reduce the current ripple and obtain the target average LED current. A 1μF capacitor and an R_{CS} as shown in the above calculation are a good start point to obtain an acceptable result. Since it takes some effort, it can reduce the inductor size/cost significantly.

Typical Performance Characteristics

There are many different factors to influence efficiency of the application, such as the output power, working frequency, power supply circuit of the HT7L4091 and so on. The following are some measured results.

Efficiency vs. Power Supply Circuit – Working Frequency

There are several different power supply circuits for the device. Reference to the “Application circuit” for some examples. The different circuits provide different advantages, such as high efficiency or low cost.

Follow are some efficiency compare for different power supply circuits. The condition is VAC=85V~260V, $F_{PWM} \geq 50kHz$ (working frequency), output=52V×0.2A=10.4W. Decreasing F_{PWM} or increasing the output power can enhance the efficiency.

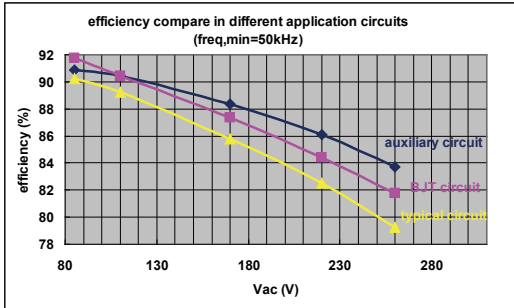

The following is an example to enhance the efficiency by reducing the F_{PWM} (working frequency) to $\geq 30kHz$.

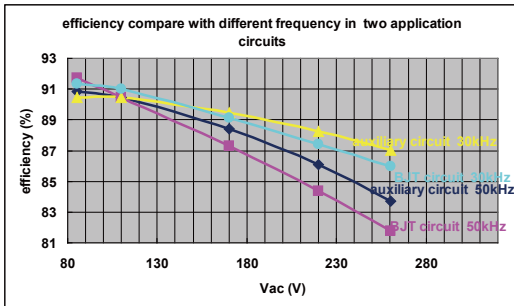

Efficiency for Resistor Only Power and Single Input Voltage

The results of these curves are that each voltage corresponds to each input limit resistor. These results show how good the application is designed for a narrow voltage range using a resistor to power the device.

The “LED string” means how many LEDs are in one string. 16S means there are 16 LEDs in one string.

The output (LED) power is kept at 10W.

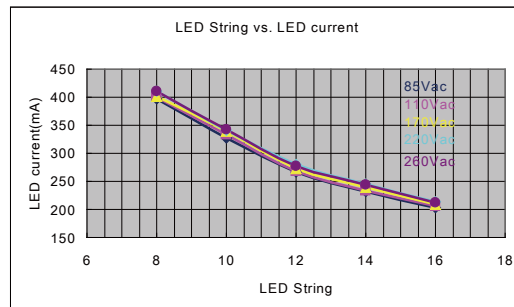
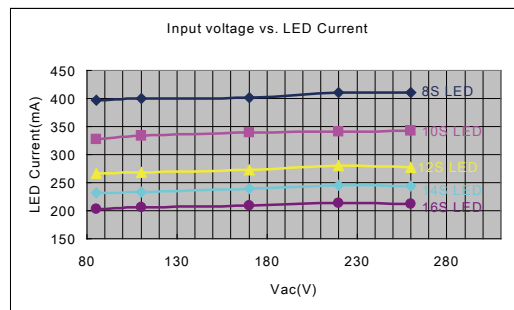
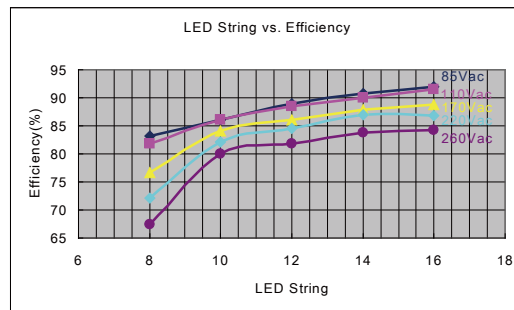
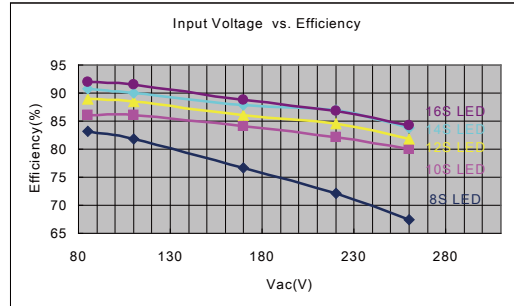

Efficiency Using Resistor Only Power and 85~265 V_{AC} Input

These result curves use the same input limit resistor with different voltages. These results show the performance only using a resistor to power up the device for a full range voltage input. For improved efficiency with a full range voltage input, refer to the following application circuit.

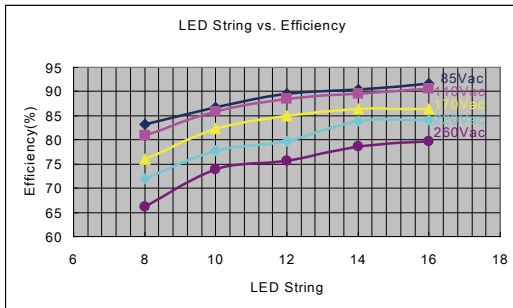
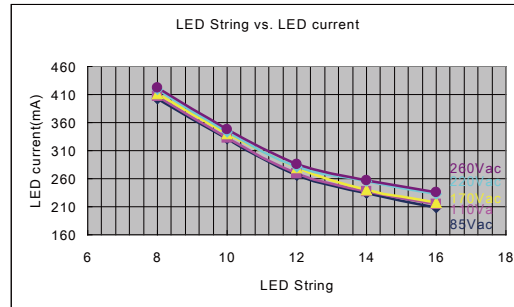
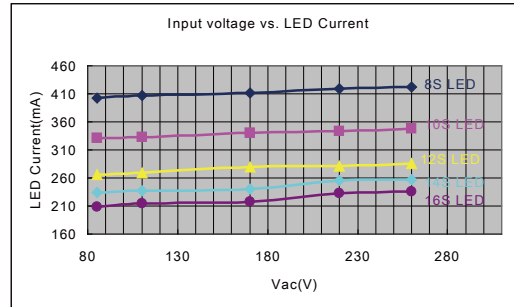
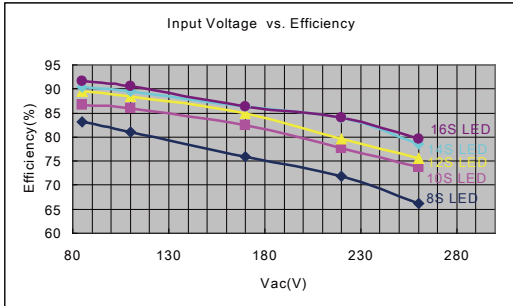

Typical Application Circuit

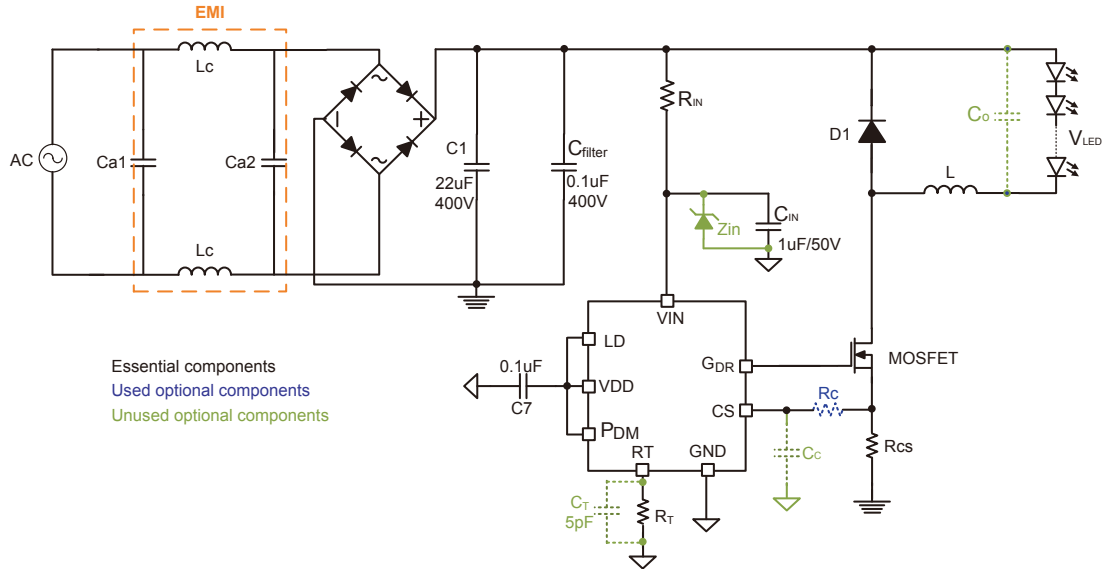

This typical application circuit uses a fundamental buck converter circuit. Adding a CO capacitor can reduce the LED current ripple or reduce the inductor size while adding the RC and CC components can reduce spikes on the CS pin.

If frequency jittering is considered to reduce EMI an optional 5pF CT may be used to stabilise the effect.

Other Application Circuit

No Input Bulk Capacitor Circuit

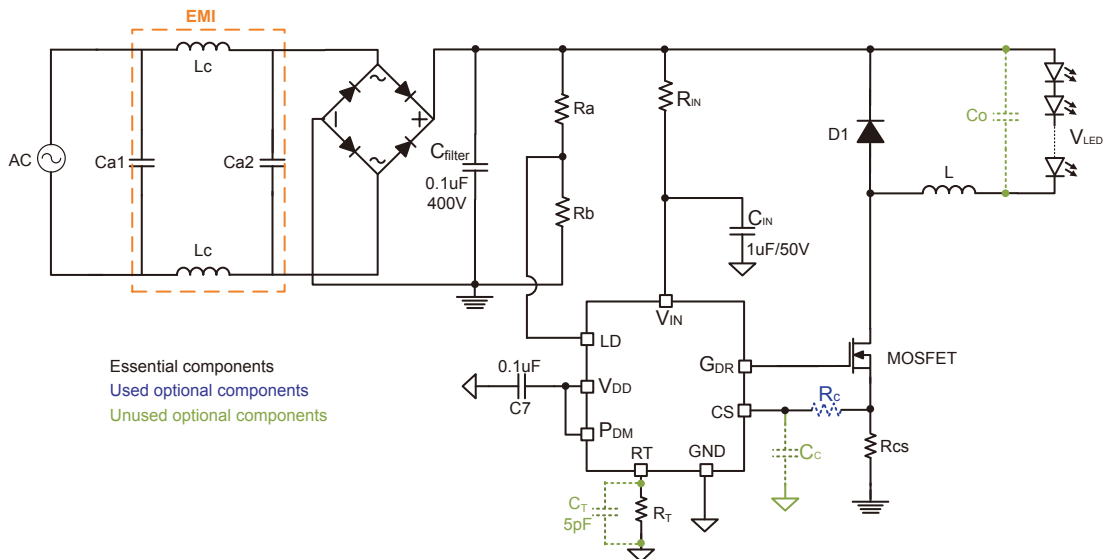

The application circuit is a low cost implementation which can improve the PF used within the signal input voltage range.

The auxiliary winding application circuit can be chosen when used for a universal input voltage. If frequency jittering is considered to reduce EMI effects, an optional 5pF capacitor may be added for stabilisation purposes. Refer to the application notes for more details.

For more details refer to the application note.

High Efficiency Circuit

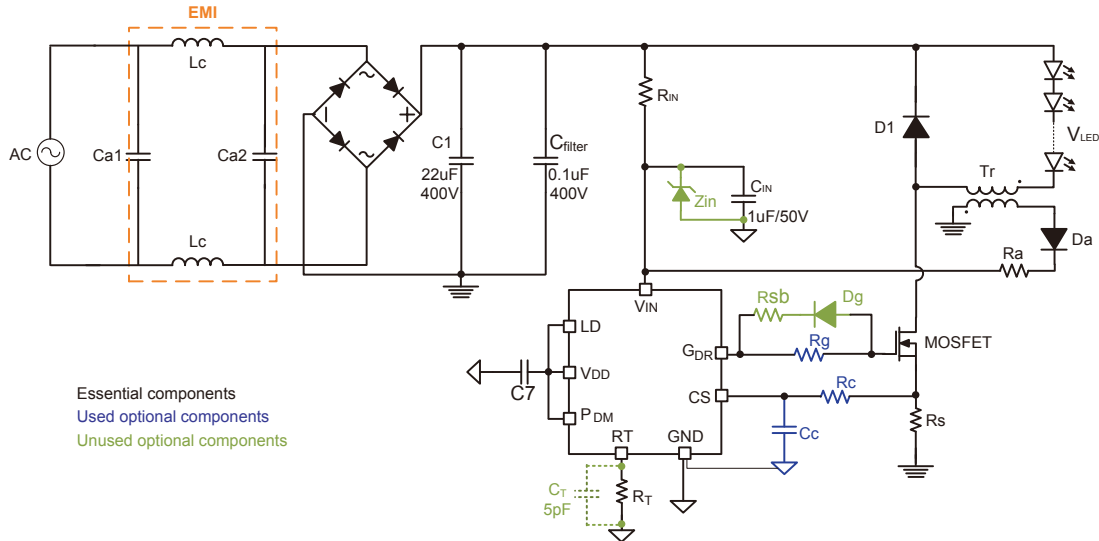

The application circuit uses the auxiliary inductor to supply the device power to obtain better efficiency.

If frequency jittering is used to reduce EMI interference effects, an optional 5pF capacitor may be used for stabilisation purposes. For more details, refer to the application note for auxiliary inductor applications.

For more details refer to the application note.

BJT Power Supply Application Circuit

The application circuit uses a BJT to supply the device power to obtain better efficiency.

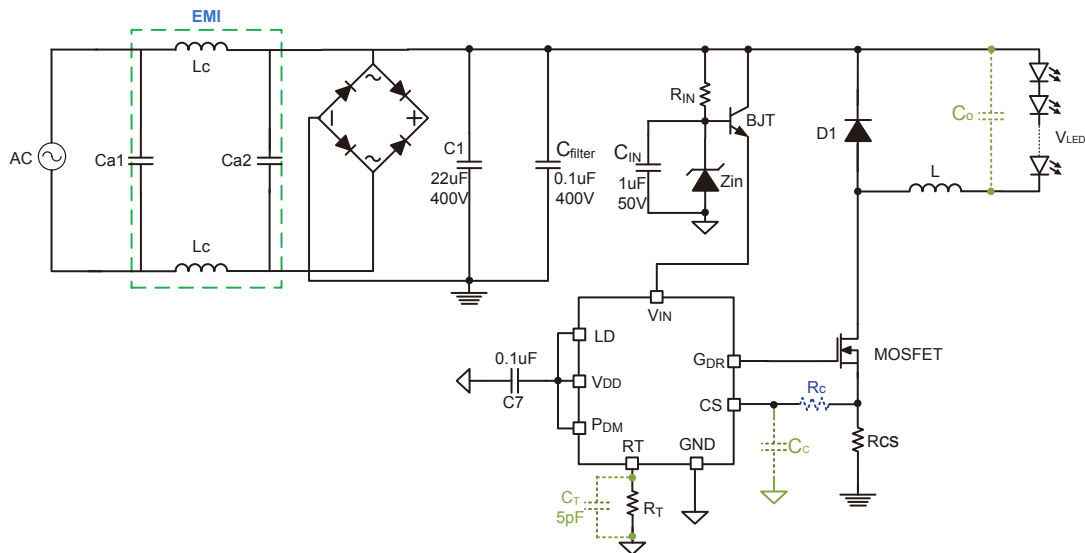

If frequency jittering is considered to reduce EMI an optional 5pF CT may be used to stabilise the effect.

For more details refer to the application note.

Bill of Materials

AC Input voltage: $V_{AC_typ} = 110V_{rms}$; $V_{AC_min} = 95V_{rms}$; $V_{AC_max} = 115V_{rms}$, $f_{PWM} \geq 40kHz$

Output Voltage: LED string Voltage = 24~26.4V

Average Output LED Current: $I_{LED} = 400mA$

R+L+EMI circuit (8S20P)				
Components	Quantity	Value	Package	Part Number
R_T	1	390k Ω + 13k Ω	SMD 0805	—
R_{CS}	1	R300(0.3 Ω)+R240(0.24 Ω)	SMD 1206	—
C_1	1	22 μF / 200V	CapXon Radial	FK series
C_{filter}	1	0.1 μF / 200V	Radial	—
R_{IN}	1	30k Ω /1W x 2	AXIAL-0.6	—
C_{IN}	1	1 μF / 50V	SMD 0805	—
LED	160	3~3.3V/30mA	Everlight P-LCC-2	L2C-B4556AC2CB2
MOSFET	1	2A/600V	NIKO-SEM DPAK	P0260AD
C_7	1	0.1 μF	SMD 0805	—
D_{Bridge}	1	1A/400V	DF-S	DF04S-T
D_1	1	2A/600V	SMB	STTH2R06U
U_1	1	HT7L4091	NSOP8	HOLTEK
L	1	3.8mH	Coilcraft 335D	CM6676-AL

Package Information

Note that the package information provided here is for consultation purposes only. As this information may be updated at regular intervals users are reminded to consult the [Holtek website](#) for the latest version of the package information.

Additional supplementary information with regard to packaging is listed below. Click on the relevant section to be transferred to the relevant website page.

- [Further Package Information](#) (include Outline Dimensions, Product Tape and Reel Specifications)
- [Packing Materials Information](#)
- [Carton information](#)
- [PB FREE Products](#)
- [Green Packages Products](#)

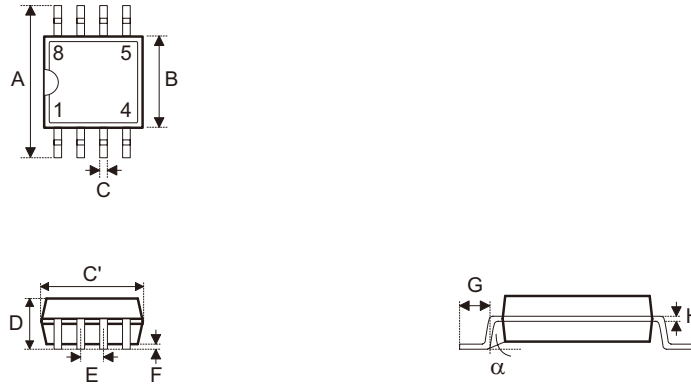
8-pin SOP (150mil) Outline Dimensions

• MS-012

Symbol	Dimensions in inch		
	Min.	Nom.	Max.
A	0.228	—	0.244
B	0.150	—	0.157
C	0.012	—	0.020
C'	0.188	—	0.197
D	—	—	0.069
E	—	0.050	—
F	0.004	—	0.010
G	0.016	—	0.050
H	0.007	—	0.010
α	0°	—	8°

Symbol	Dimensions in mm		
	Min.	Nom.	Max.
A	5.79	—	6.20
B	3.81	—	3.99
C	0.30	—	0.51
C'	4.78	—	5.00
D	—	—	1.75
E	—	1.27	—
F	0.10	—	0.25
G	0.41	—	1.27
H	0.18	—	0.25
α	0°	—	8°

Copyright© 2013 by HOLTEK SEMICONDUCTOR INC.
The information appearing in this Data Sheet is believed to be accurate at the time of publication. However, Holtek assumes no responsibility arising from the use of the specifications described. The applications mentioned herein are used solely for the purpose of illustration and Holtek makes no warranty or representation that such applications will be suitable without further modification, nor recommends the use of its products for application that may present a risk to human life due to malfunction or otherwise. Holtek's products are not authorized for use as critical components in life support devices or systems. Holtek reserves the right to alter its products without prior notification. For the most up-to-date information, please visit our web site at <http://www.holtek.com>.