

Features

- Allowable max input voltage: 26V
- Built-in Power MOSFET
- Output voltage up to 40V driving 10 series LEDs – LED $V_{f(max)}=3.5V$ per string – absolute max rating up to 44V
- Channel Phase Shift PWM Dimming
- Direct PWM Dimming without Phase Shift
- Operate up to 11 strings LED at $V_{f(max)}=3.3V$ condition
- Low string feedback voltage: 0.5V at 80mA LED current
- Switching frequency: 200kHz/400kHz
- 8-string constant current output
- LED current adjustable from 60mA to 80mA
- $\pm 2.5\%$ current matching between strings
- Dimming control using PWM
- 1% minimum dimming duty-cycle at 2kHz
- Built- in Soft start
- LED failure detection: open and short circuit
- Capacitor type: ceramic
- Protection: OVP, OTP, UVLO, LX current limit
- 48-Pin 7x7x1.0mm TQFP-EP package

Applications

- LED backlights for LCD monitor and LCD TV

General Description

The HT7955 is a high efficiency DC-DC controller drives a number of WLEDs connected in series/parallel configuration and has a wide input voltage range from 10V to 26V, and adjustable 60mA to 80mA WLED current by external resistor. In total, the device can support up to 80 WLED.

In addition, six current sink regulators provide $\pm 2.5\%$ high precision current matching between strings. The brightness can be adjusted by external PWM up to 2kHz. Once an open/short string is detected, the string is disabled while other strings operate normally.

Other protecting includes soft-start, under voltage lockout, programmable over voltage protection, WLED current limit, switch current limit and thermal shutdown.

The HT7955 is packaged with a tiny footprint package of 48-Pin 7x7x1.0mm TQFP-EP package.

Block Diagram

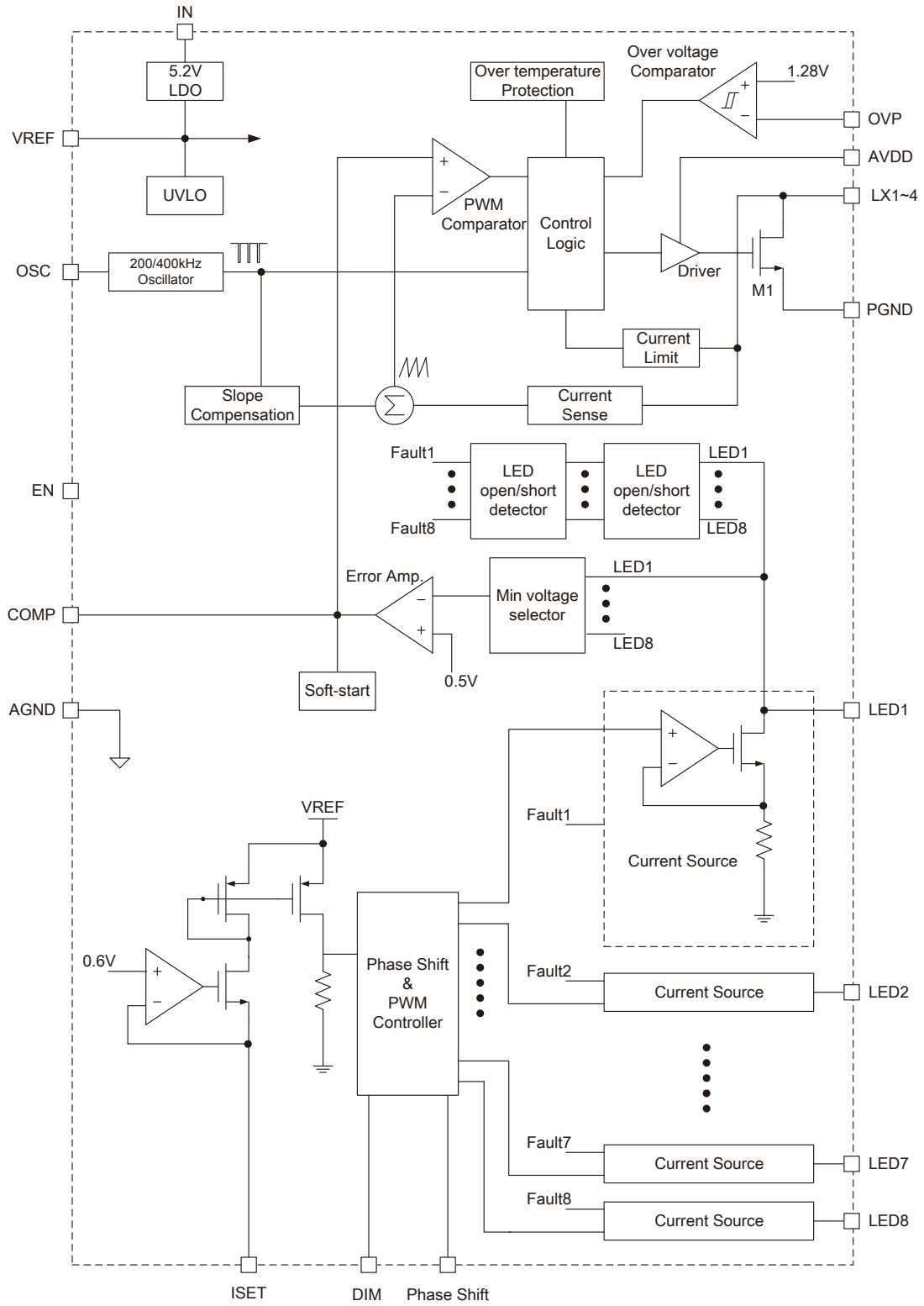

Pin Assignment

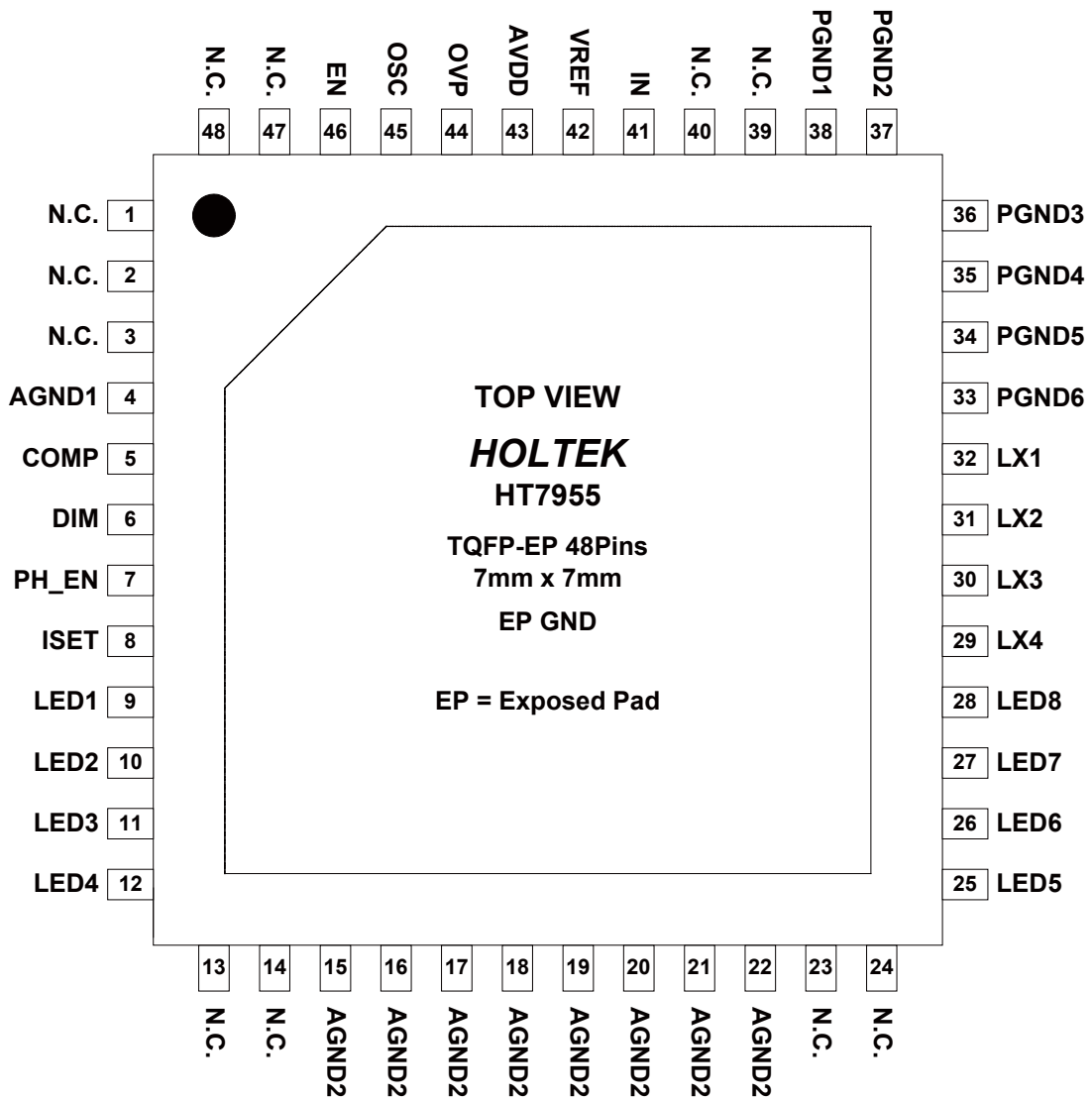

Pin Description

PIN	Name	Description
46	EN	Enable Input. When low or left open, the device is turned off. If tied high, the device is active.
4,15-22	AGND	Analog Ground.
7	Phase Shift	PWM Dimming Enable Input. When connected to VREF or floating, Phase Shift PWM Dimming is enabled. When connected to AGND, Phase Shift PWM Dimming is disabled.
5	COMP	Error Amplifier Output. A simple RC network between this pin and AGND is needed to compensate the boost regulator feedback loop.
6	DIM	Dimming Control Input. LED backlight PWM dimming control input pin.
8	ISET	Full Scale LED Current Adjustment Pin. By selecting the resistor connected from this pin to AGND.
9-12, 25-28	LED1, LED2, LED3, LED4, LED5, LED6, LED7, LED8	LED Current Sink Outputs. Open Drain LED drive pins. Can sink up to 80mA. If unused, leave open.
29, 31, 32	LX1, LX2, LX3	Switching Node. Internal Power MOSFET Drain. Connected to the inductor and schottky diode.
33-37	PGND	Power Ground. Power MOSFET return path.
41	IN	Input Voltage. Range from 10V to 26V, bypass IN to AGND directly at the pin with 0.1 μ F or greater ceramic capacitor.
42	VREF	Internal 5.2V LDO Output. Bypass to AGND with a 10 μ F or greater ceramic capacitor.
43	AVDD	Power MOSFET Gate Drive Supply. Bypass AVDD to AGND with a ceramic capacitor of 10 μ F or greater.
44	OVP	Over Voltage Protection. External resistor divider used to set the desired OVP threshold. Detector threshold is 1.28V (typ.) and $V_{OVP}=V_{OUT}+3V$.
45	OSC	Oscillator Frequency Select Input. Connect OSC to VREF to set the converter's oscillator frequency to 200kHz. Connect OSC to AGND to set the frequency to 400kHz.
1-3, 13, 14, 23, 24, 30, 38-40, 47, 48	N.C.	No Connect.
—	EP	Exposed Pad. Connection to GND plane of the PCB.

Absolute Maximum Ratings

IN, EN	31V	Operating Temperature Range	-40°C ~ +85°C
LED1~LED8, LX1, LX2	44V	Maximum Junction Temperature	+150°C
AVDD, OVP.....	6V	LED Current.....	100mA

Note: These are stress ratings only. Stresses exceeding the range specified under “Absolute Maximum Ratings” may cause substantial damage to the device. Functional operation of this device at other conditions beyond those listed in the specification is not implied and prolonged exposure to extreme conditions may affect device reliability.

Electrical Characteristics

Refer to circuit of Figure 1, $EN = V_{IN} = 18V$, $AV_{DD} = V_{REF}$, $T_a = 25^\circ C$, unless otherwise specified. (Note 2)

Parameter	Test Conditions	Min.	Typ.	Max.	Unit
Supply Selection					
IN Input Voltage	—	10	—	26	V
IN Quiescent Current	$EN = V_{REF}$	—	5	—	mA
	$EN = GND$	—	—	10	μA
VREF Output Voltage	$6.0V < V_{IN} < 26V$, (Only for internal circuit used)	5.00	5.20	5.45	V
VREF UVLO Threshold	Rising edge, typical hysteresis=85mV	3.60	3.80	4.00	V
Boost Selection					
Switching Frequency	$OSC = AGND$	280	400	520	kHz
	$OSC = V_{REF}$	140	200	260	MHz
LX_Internal MOSFET Current Limit	—	—	3.6	—	A
LX_Internal MOSFET $R_{DS(ON)}$	—	—	0.3	—	Ω
Maximum Duty Cycle	—	—	94	—	%
Control Selection					
Enable High Level Threshold Voltage	—	2	—	—	V
Enable Low Level Threshold Voltage	—	—	—	0.8	
Dimming PWM Frequency	—	—	2	—	kHz
Dimming PWM High Level Threshold	—	2	—	—	V
Dimming PWM Low Level Threshold	—	—	—	0.8	
LED_Selection					
LED_Current	$R_{ISET} = 18K$	74	80	86	mA
LED_Current Regulation Between Strings	$I_{LED} = 80mA$	—	± 2.5	± 5.0	%
LED_Open Detector Threshold	$LED_ = Open$	150	200	250	mV
LED_Short Detector Threshold	$LED_ = V_{OUT}$	5.2	5.6	6.0	V
OVP Threshold Voltage	—	1.21	1.28	1.35	V
Thermal Selection					
Thermal Shutdown Temperature	—	—	160	—	$^\circ C$
Thermal Shutdown Hysteresis	—	—	50	—	

Note: Specifications over the $-40^\circ C$ to $85^\circ C$ operating temperature range are assured by design.

LED Open Detector Protection

The device includes an LED open protection function. If any one of ISEN pins is disconnected from the LED load, the device will stop driving the ISEN pin, automatically ignoring the open pin. The LED current of the other ISEN pins will not be influenced by any open ISEN pin. When the open ISEN pins are re-connected to the LED load, there will be no current. These ISEN pins will remain disabled until the power is recycled.

LED Short Detector Protection

The device includes an LED short circuit protection function. If more than 2~3 LEDs are short circuited on any ISEN pin or the voltage level of the ISEN pin is greater than 5.6V, the device will turn off that ISEN pin and automatically ignore the shorted pin. The LED current of other ISEN pins will not be influenced by any shorted ISEN pins. If even only one ISEN pin remains operational due to shorts on other pins, it will still maintain normal operation. The shorted ISEN pins remain disabled until the power is recycled.

Over-Temperature protection – OTP

An internal thermal shutdown function is included to prevent device damage due to excessive heat and power dissipation. Typically, the thermal shutdown threshold of is 160°C. When the thermal shutdown function is activated, the device stops switching until the temperature falls to below 110°C typically. When this occurs the device resumes switching once again.

Soft Start Function

Converter operation starts immediately after power on. In order to avoid the possibility of large in-rush currents to the load during this power on period, a soft-start function is implemented to prevent this problem from occurring.

Application Information

Inductor Selection

The inductor choice affects steady state operation as well as transient behavior and loop stability. There are three important electrical parameters which need to be considered when choosing an inductor:

- The inductor value
- DCR – copper wire resistance
- The saturation current

Inductor choice is especially important as it is required to ensure the inductor does not saturate under its peak current conditions. The general rule is to keep the inductor current peak-to-peak ripple at approximately 30% of the nominal output current. As a typical example, when using the HT7955 boost converter, operating in both discontinuous and continuous conduction modes, the typical application circuit value of the inductor, L1, would be around 33μH.

Input/Output Capacitor

Output Capacitor

The output capacitor determines the steady state output voltage ripple. In the compensation parameters, the output capacitor is one of the parameters, and if the capacitance is too big or too small, it can cause system instability. Its value must be based on the application circuit recommended output capacitor value. A low ESR ceramic capacitor is required to keep noise to a minimum. A 20μF ceramic capacitor is suitable for typical applications.

Input Capacitor

An input capacitor is required to supply the ripple current to the inductor and is also used to limit the input noise, allowing the device to obtain a stable DC power supply. As the input capacitance is not a compensation parameter there are no stability problems, however a capacitor must always be connected along with an input power supply. For typical applications, a 4.7μF ceramic capacitor is sufficient. This capacitor must be connected very close to the VIN pin and inductor, with short traces for good noise performance.

Schottky Diode

It is recommended to use a Schottky diode with a low forward voltage to minimise power dissipation and therefore maximise the converter efficiency. The average and peak current ratings must be greater than the maximum output current and peak inductor current. There are three important electrical parameters to consider when choosing the diode:

- The diode maximum reverse voltage value must be greater than the maximum output voltage.
- Short recovery time and low forward voltage – use a Schottky diode type.
- Diode current rating should be greater than the maximum load current.

Compensation Components

The COMP pin is the output of the error amplifier and must be properly connected to an external RC network to ensure regulator loop stability. Recommended values are: $R_{Comp}=24k\Omega$, $C_{Comp}=1.5nF$ and $C_{comp}=100pF$.

Oscillator Frequency Setup

There are two frequency options available. The OSC pin default switching frequency is 200kHz when the pin is unconnected and 400kHz when the pin is connected to ground.

LED current Setup

The LED current can be setup using an external resistor connected from the ISENT pin to ground. The following equation shows how the current is calculated.

This shows how the Led reference current can be setup at LED1~6 and represents the sensed LED current for each string. The LED current regulation between the strings has good accuracy at $\pm 2.5\%$.

Dimming Control

The device includes an external PWM signal dimming control. PWM dimming control is achieved by applying an external PWM signal with a frequency of 100Hz to 2kHz. The high level of this signal must be greater than 2.0V and the low level must be less than 0.8V. A 0% duty cycle corresponds to zero LED current while a 100% duty cycle corresponds to full LED current.

Layout Considerations

Circuit board layout is a very important consideration for switching regulators if they are to function properly. Poor circuit layout may result in related noise problems. In order to minimise EMI and switching noise, the guidelines should be noted:

- All tracks should be as wide as possible.
- The input and output capacitors, CIN and COUT, should be located close to the VIN, VOUT and GND pins.
- The Schottky diode, D1, and inductor, L1, must be located close to the LX pin.
- The AGND analog ground pins, and PGND power ground pins, must have independent connections, but must be connected together at some final point on the user circuit board.

A recommended PCB layout with component locations is enclosed.

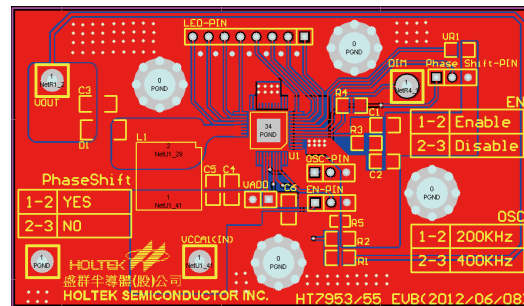

Top Layer

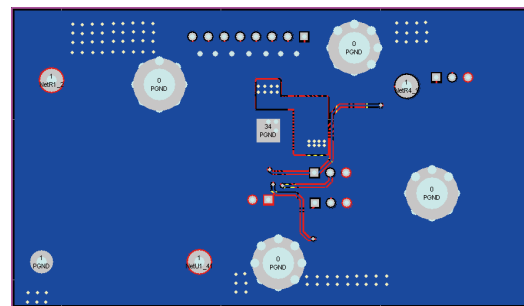

Bottom Layer

Typical Performance Characteristics

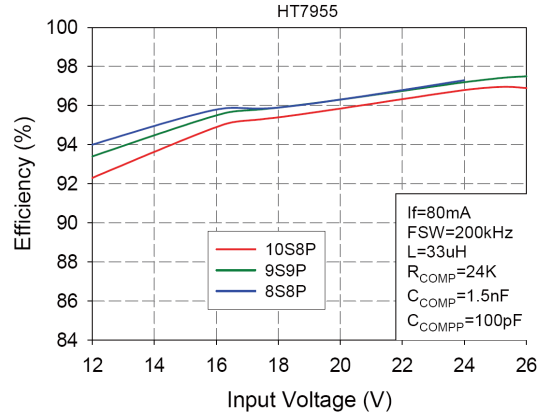
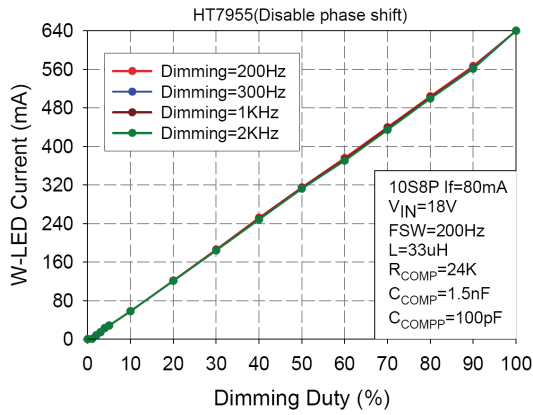
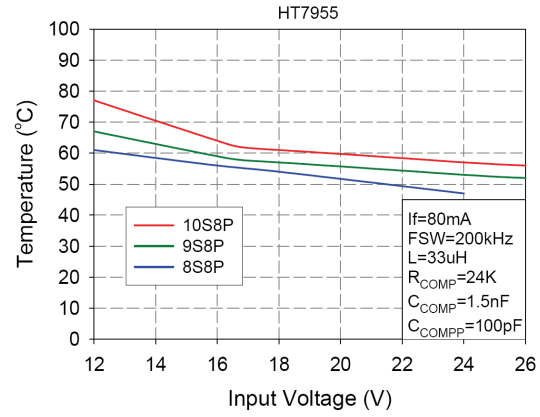
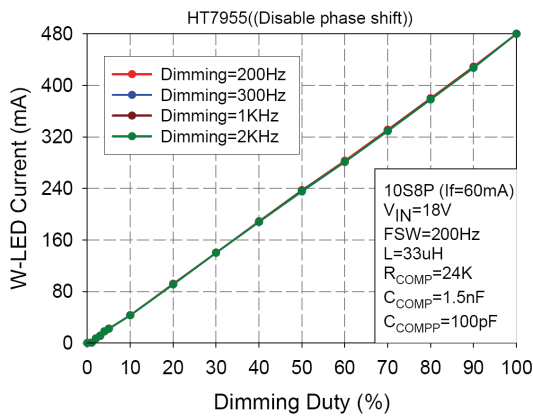
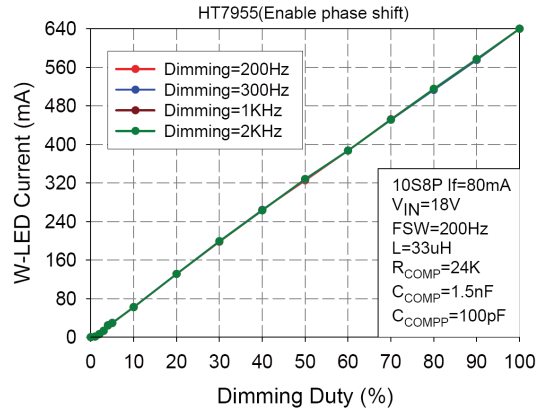
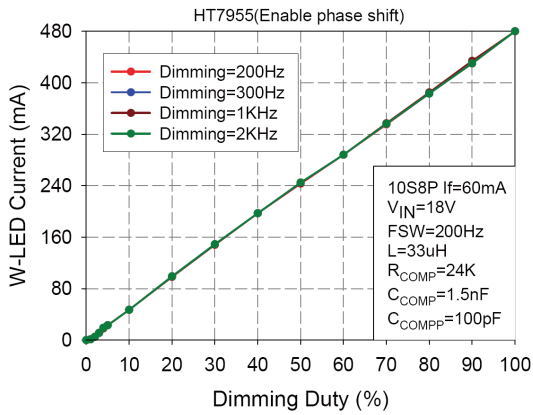

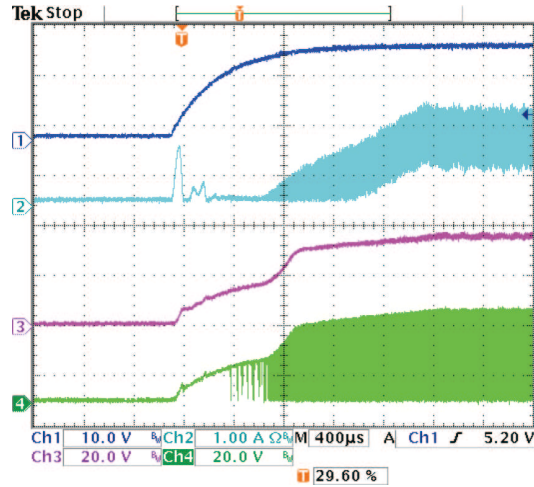
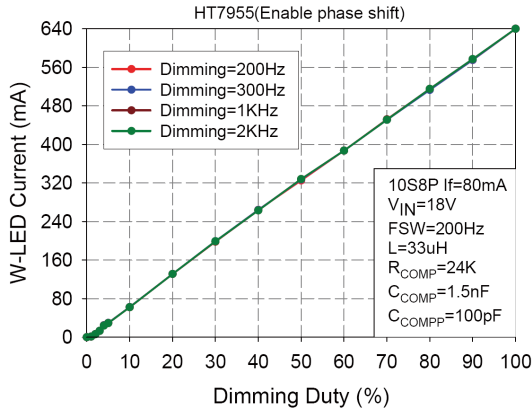

10S8P Start Up Waveform
VIN=18V, L=33µH, CIN=4.7µF, COUT=20µF
(CH1=VIN, CH2=Inductor Current, CH3=VOUT,
CH4=Switching Pin)

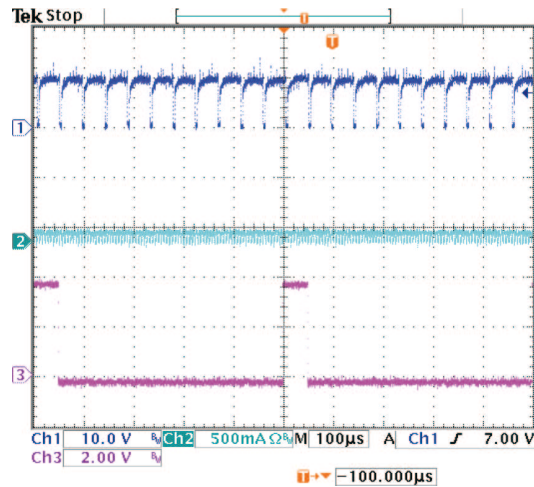
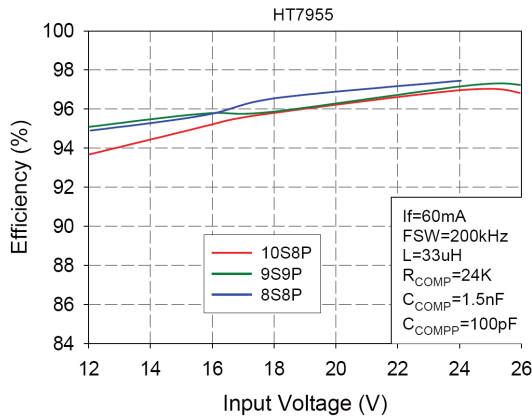

10S8P Dimming Waveform Dimming=2kHz
D=10%, VIN=18V, L=33µH, CIN=4.7µF, COUT=20µF
(enable phase shift)
(CH1=one of LED channel Feedback Voltage,
CH2=LED Current, CH3=Dimming Signal)

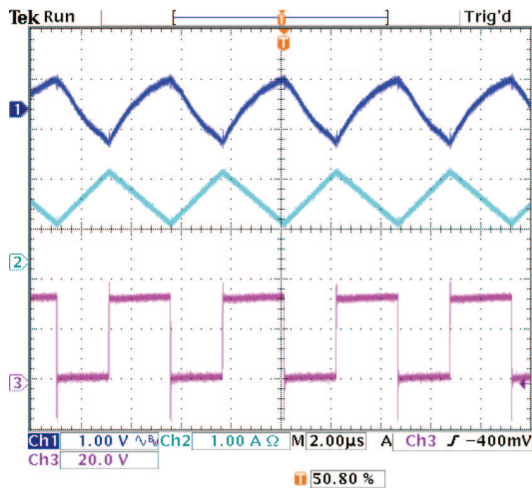

10S8P Basic Waveform
VIN=18V, L=33µH, CIN=4.7µF, COUT=20µF
(CH1=VOUT(AC), CH2=Inductor Current,
CH3=Switching Pin)

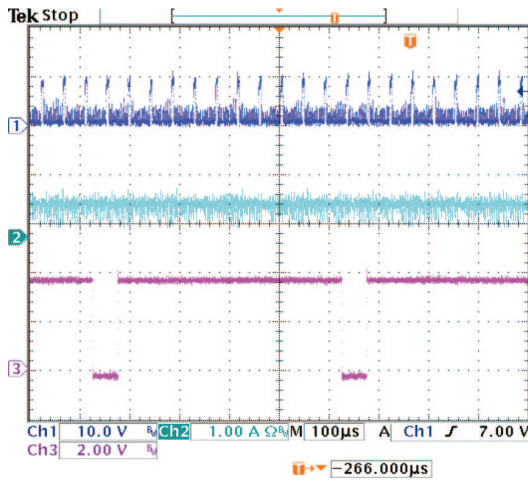

10S8P Dimming Waveform Dimming=2kHz
 D=90%, $V_{IN}=18V$, $L=33\mu H$, $C_{IN}=4.7\mu F$, $C_{OUT}=20\mu F$
 (enable phase shift)
 (CH1=one of LED channel Feedback Voltage,
 CH2=LED Current, CH3=Dimming Signal)

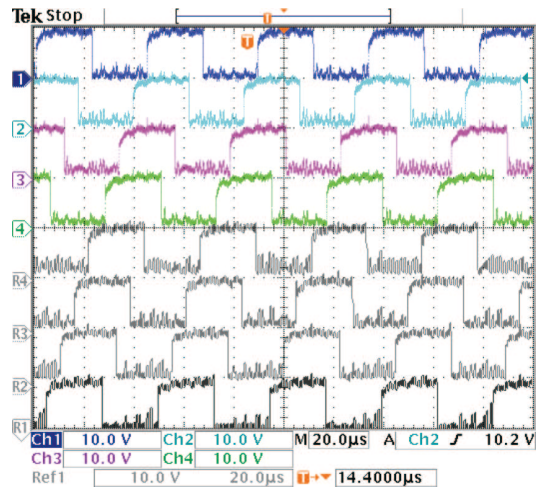

10S8P Feedback Waveform Dimming=2kHz
 D=50%, $V_{IN}=18V$, $L=33\mu H$, $C_{IN}=4.7\mu F$, $C_{OUT}=20\mu F$
 (enable phase shift)
 (R1=Feedback1, R2=Feedback2, R3=Feedback3,
 R4=Feedback4, CH4=Feedback5, CH3=Feedback6,
 CH2=Feedback7, CH1=Feedback8)

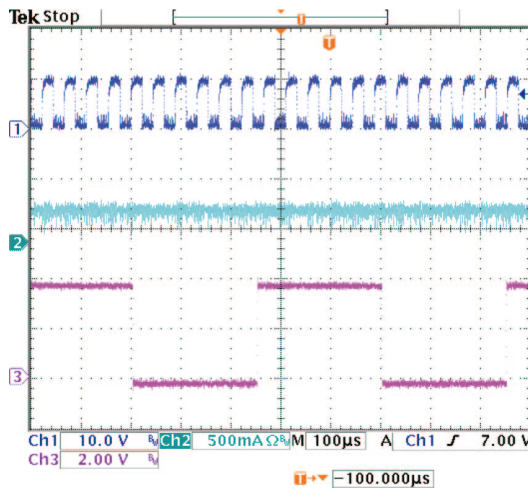

10S8P Dimming Waveform Dimming=2kHz
 D=50%, $V_{IN}=18V$, $L=33\mu H$, $C_{IN}=4.7\mu F$, $C_{OUT}=20\mu F$
 (enable phase shift)
 (CH1=One of LED Channel Feedback Voltage,
 CH2=LED Current, CH3=Dimming Signal)

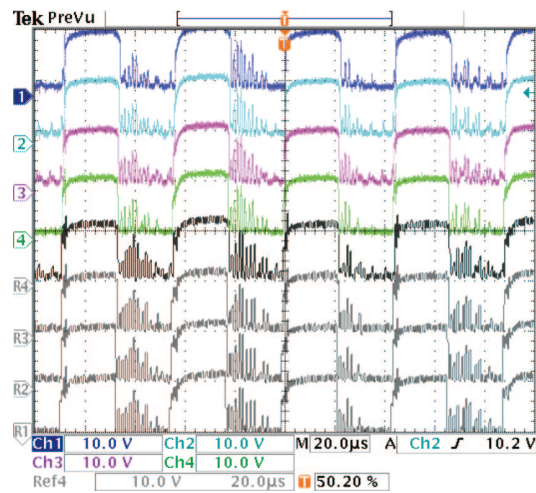

10S8P Feedback Waveform Dimming=2kHz
 D=50%, $V_{IN}=18V$, $L=33\mu H$, $C_{IN}=4.7\mu F$, $C_{OUT}=10\mu F$
 (Disable phase shift)
 (R1=Feedback1, R2=Feedback2, R3=Feedback3,
 R4=Feedback4, CH4=Feedback5, CH3=Feedback6,
 CH2=Feedback7, CH1=Feedback8)

Package Information

Note that the package information provided here is for consultation purposes only. As this information may be updated at regular intervals users are reminded to consult the Holtek website (<http://www.holtek.com.tw/english/literature/package.pdf>) for the latest version of the package information.

48-pin TQFP (7mm×7mm) Outline Dimensions for Thermally Enhance (Exposed Pad)

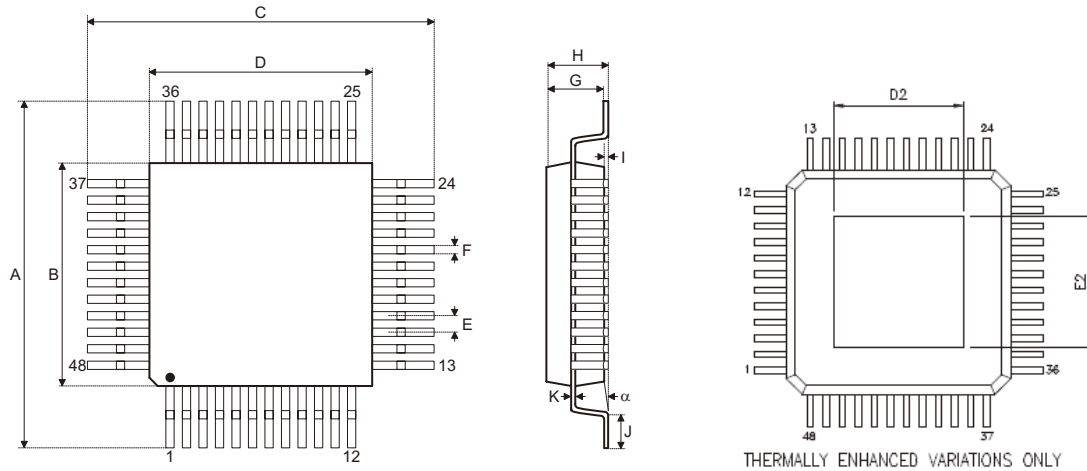

MS-026

Symbol	Dimensions in inch		
	Min.	Nom.	Max.
A	—	0.354	—
B	—	0.276	—
C	—	0.354	—
D	—	0.276	—
E	—	0.020	—
D2	—	0.160	—
E2	—	0.160	—
F	0.007	—	0.011
G	0.037	0.039	0.041
H	—	—	0.047
I	0.002	0.004	0.006
J	0.018	—	0.030
L	0.004	—	0.008
α	0°	—	7°

Symbol	Dimensions in mm		
	Min.	Nom.	Max.
A	—	9.00	—
B	—	7.00	—
C	—	9.00	—
D	—	7.00	—
E	—	0.50	—
D2	—	4.06	—
E2	—	4.06	—
F	0.17	—	0.27
G	0.95	1.00	1.05
H	—	—	1.20
I	0.05	0.10	0.15
J	0.45	—	0.75
L	0.09	—	0.20
α	0°	—	7°

Holtek Semiconductor Inc. (Headquarters)

No.3, Creation Rd. II, Science Park, Hsinchu, Taiwan
Tel: 886-3-563-1999
Fax: 886-3-563-1189
<http://www.holtek.com.tw>

Holtek Semiconductor Inc. (Taipei Sales Office)

4F-2, No. 3-2, YuanQu St., Nankang Software Park, Taipei 115, Taiwan
Tel: 886-2-2655-7070
Fax: 886-2-2655-7373
Fax: 886-2-2655-7383 (International sales hotline)

Holtek Semiconductor (China) Inc. (Dongguan Sales Office)

Building No.10, Xinzhu Court, (No.1 Headquarters), 4 Cuizhu Road, Songshan Lake, Dongguan, China 523808
Tel: 86-769-2626-1300
Fax: 86-769-2626-1311, 86-769-2626-1322

Holtek Semiconductor (USA), Inc. (North America Sales Office)

46729 Fremont Blvd., Fremont, CA 94538, USA
Tel: 1-510-252-9880
Fax: 1-510-252-9885
<http://www.holtek.com>

Copyright© 2012 by HOLTEK SEMICONDUCTOR INC.

The information appearing in this Data Sheet is believed to be accurate at the time of publication. However, Holtek assumes no responsibility arising from the use of the specifications described. The applications mentioned herein are used solely for the purpose of illustration and Holtek makes no warranty or representation that such applications will be suitable without further modification, nor recommends the use of its products for application that may present a risk to human life due to malfunction or otherwise. Holtek's products are not authorized for use as critical components in life support devices or systems. Holtek reserves the right to alter its products without prior notification. For the most up-to-date information, please visit our web site at <http://www.holtek.com.tw>.