

Features

- Max input voltage: 26V
- Integrated Power Mosfet
- Output voltage up to 40V driving 11 series LEDs – LED $V_{f(max)}=3.5V$ per string – absolute max rating up to 44V
- Channel Phase Shift PWM Dimming
- Drives up to 12 LED strings under $V_{f(max)}=3.3V$ condition
- Low string feedback voltage: 0.8V at 20mA LED current
- Switching frequency: 500kHz/1MHz
- 6-string constant current output
- LED current adjustable from 15mA to 30mA
- $\pm 1.5\%$ current matching between strings
- PWM dimming control
- 1% minimum dimming duty-cycle at 2kHz
- Integrated soft start function
- LED failure detection: open and short circuit
- Capacitor type: ceramic
- Protection: OVP, OTP, UVLO, SW current limit
- Small 20-pin outline package: 4mm \times 4mm, thin QFN type

Applications

- LED backlights for notebook and tablet PC

General Description

The HT7943 is a high efficiency DC-DC controller for driving a number of WLEDs connected both in series and parallel configurations. The device has a wide input voltage range from 4.5V to 26V and an adjustable 15mA to 30mA WLED current, setup using an external resistor. In total, the device can drive up to 66 WLEDs.

In addition, six current sink regulators provide $\pm 1.5\%$ high precision current matching between strings. Brightness can be adjusted by an external PWM signal up to 20kHz. If an open/short string is detected, the string is disabled while the other strings operate normally.

Other protection features include soft-start, under voltage lockout, programmable over voltage protection, switch current limit and thermal shutdown.

The device is supplied in a tiny 20-pin 4mm \times 4mm QFN package.

Block Diagram

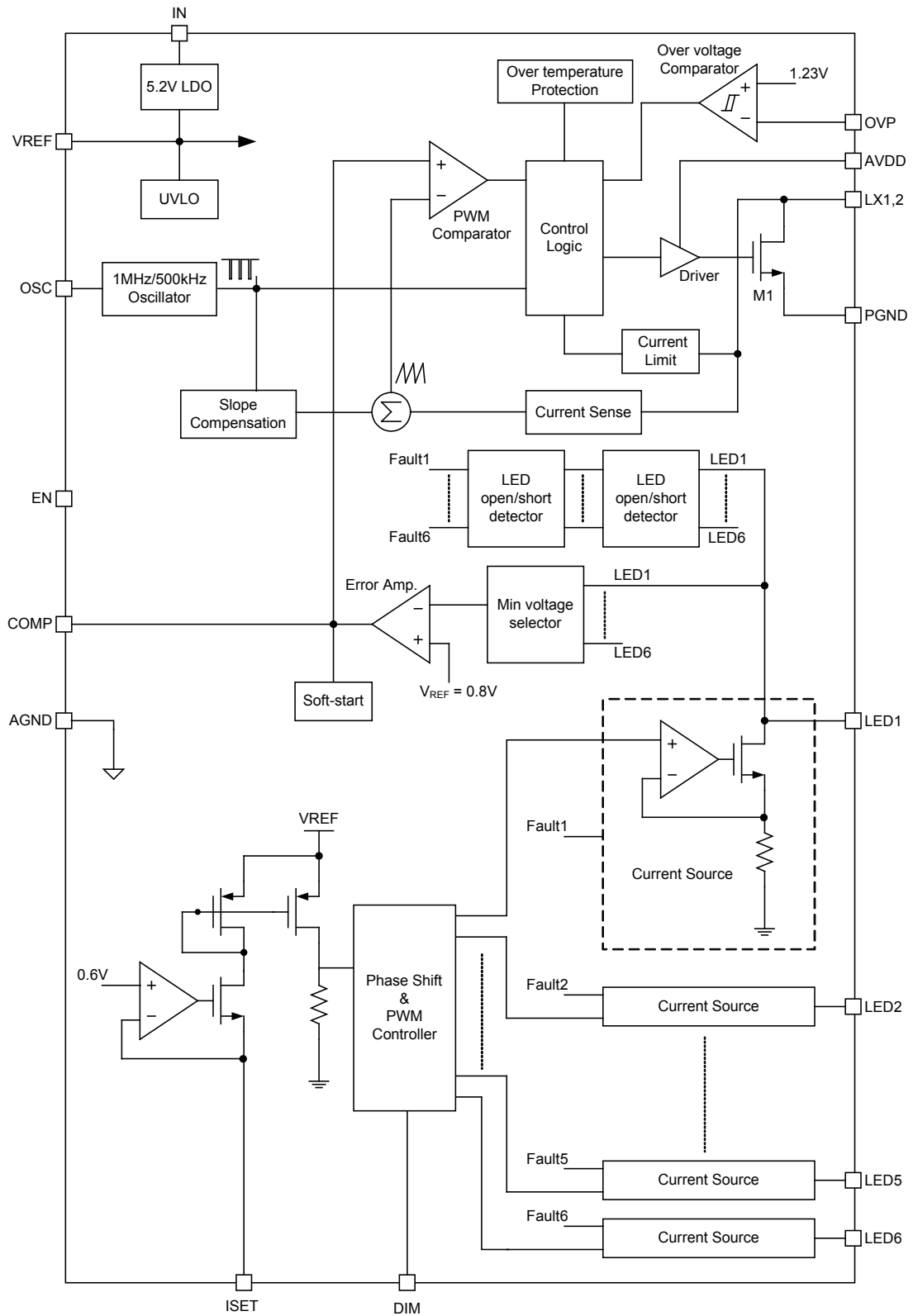

Pin Assignment

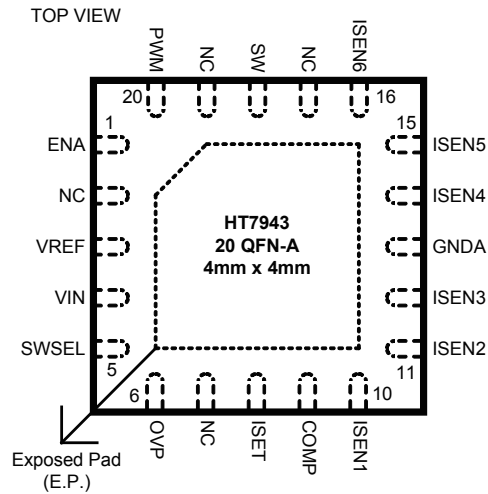

Pin Description

PIN	Name	Description
1	ENA	Enable Input. When low, the device is powered down. If tied high or left open, the device is active.
2, 7, 17, 19	NC	No connection
3	VREF	Internal 5.2V LDO Output. Bypassed to GNDA with a 10 μ F or greater ceramic capacitor. If V_{IN} is less than or equal to 6.0V, tie VREF to V_{IN} to disable the internal LDO.
4	VIN	Input Voltage. Input voltage range from 4.5V to 26V. Bypass V_{IN} to GNDA directly at the pin with a 0.1 μ F or greater ceramic capacitor.
5	SWSEL	Switching Frequency Selection. SWSEL is connected to an internal pull-high resistor and can be left floating to set the converter switching frequency to 1MHz. Connect the pin to GNDA to set the frequency to 500kHz.
6	OVP	Over Voltage Protection. Used to set the desired OVP threshold using an external resistor divider. The detector threshold is 1.28V(typ.). $V_{OVP}=V_{OUT}+3V$
8	ISET	Full Scale LED Current Adjustment Pin. Selection implemented by connecting a resistor between this pin and GNDA.
9	COMP	Error Amplifier Output. A simple RC series circuit is connected between this pin and GNDA for boost regulator loop compensation.
10, 11, 12 14, 15, 16	ISEN1, ISEN2, ISEN3 ISEN4, ISEN5, ISEN6	LED current sink. Internal regulator open-drain output. Can sink up to 30mA. If unused, the pins should be left open.
13	GNDA	Ground.
18	SW	Switching Output. Internal Power MOSFET drain terminal. The Inductor and Schottky Diode are connected to this pin.
20	PWM	Dimming Input. PWM control pin for the LED backlight strings. An internal pull-high resistor is connected to this pin.
—	E.P.	Exposed Pad. Connect to the GND plane of the PCB.

Absolute Maximum Ratings

V_{IN} , EN.....	28V	PWM.....	30V
ISEN1~ISEN6, SW.....	44V	Operating Temperature Range	-40°C~+85°C
OVP.....	6V	Maximum Junction Temperature	+165°C

Note: These are stress ratings only. Stresses exceeding the range specified under “Absolute Maximum Ratings” may cause substantial damage to the device. Functional operation of this device at other conditions beyond those listed in the specification is not implied and prolonged exposure to extreme conditions may affect device reliability.

Electrical Characteristics

 $T_a=25^{\circ}\text{C}$

Parameter	Test Conditions	Min.	Typ.	Max.	Unit
Supply Selection					
In Input Voltage	$V_{IN}=V_{REF}$	4.5	—	6.0	V
	$V_{REF}=\text{OPEN}$	6.0	—	26.0	
In Quiescent Current	ENA= V_{IN}	—	3.3	—	mA
	ENA=GND	—	—	10	μA
VREF Output Voltage	$6.0\text{V} < V_{IN} < 26\text{V}$, (Only for internal circuit used)	4.9	5.2	5.6	V
VREF UVLO Threshold	Rising edge, typical hysteresis=85mV	3.6	3.8	4.0	V
Boost Selection					
Switching Frequency	SWSEL=GND	335	500	665	kHz
	SWSEL=OPEN	0.67	1.00	1.33	MHz
SW_Internal MOSFET Current Limit	—	2.0	2.2	—	A
SW_Internal MOSFET $R_{DS(ON)}$	—	—	0.35	1.5	Ω
Maximum Duty Cycle	—	—	94	—	%
Control Selection					
Enable High Level Threshold Voltage	—	2	—	—	V
Enable Low Level Threshold Voltage	—	—	—	0.8	
Dimming PWM Frequency	—	—	2	—	kHz
Dimming PWM High Level Threshold	—	2	—	—	V
Dimming PWM Low Level Threshold	—	—	—	0.8	
LED_Selection					
LED_Current	$R_{ISET}=24\text{K}$	19.2	20.0	20.8	mA
LED_Current Regulation Between Strings	$I_{LED}=20\text{mA}$	—	± 1.5	± 2.5	%
LED_Open Detector Threshold	LED_=OPEN	300	400	500	mV
LED_Short Detector Threshold	LED_= V_{OUT}	5.2	5.6	6.0	V
OVP Threshold Voltage	—	1.21	1.28	1.35	V
Thermal Selection					
Thermal Shutdown Temperature	—	—	140	—	$^{\circ}\text{C}$
Thermal Shutdown Hysteresis	—	—	50	—	

Typical Application Circuit

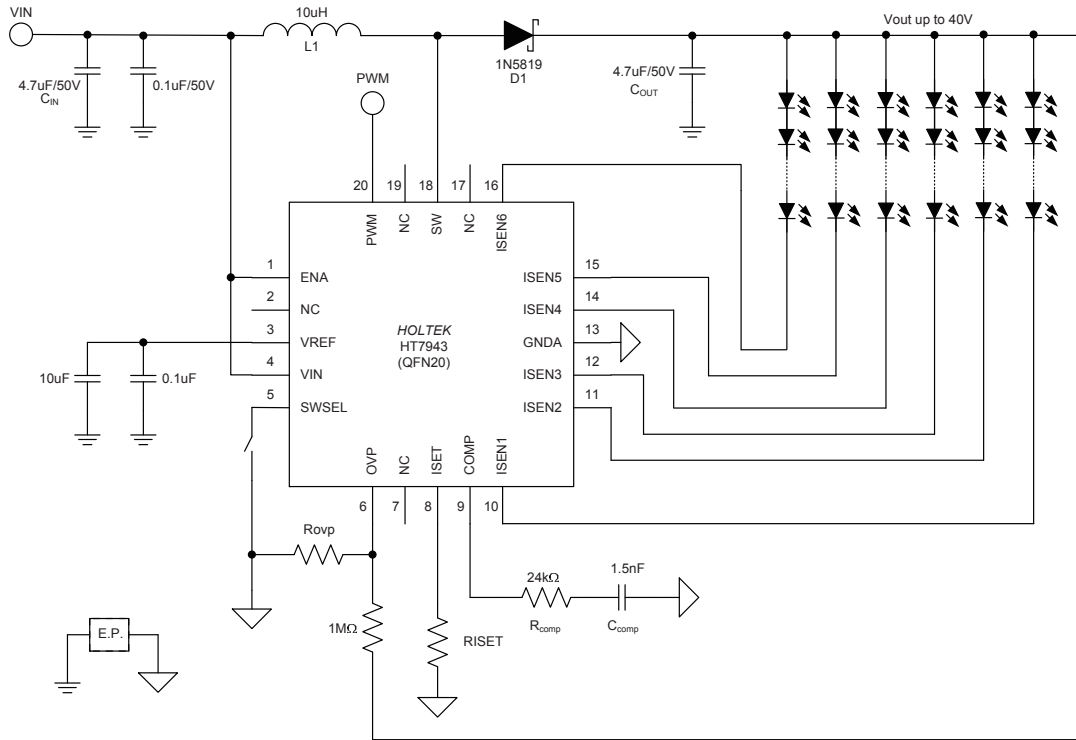

Figure 1

Functional Description

VIN Under-Voltage Lockout – UVLO

The device contains an Input Under Voltage Lockout (UVLO) circuit. The purpose of the UVLO circuit is to ensure that the input voltage is high enough for reliable operation. For low input voltage operation of 4.5V to 6V, the VREF pin is connected to the VIN pin (input voltage) to bypass the voltage regulator in which the inherent voltage drop can degrade low voltage operation. When input voltage level is below this range (4.5V to 6V) to 4.0V, then proper use is not possible. When the input voltage falls below the under voltage threshold, the internal MOSFET switch will be turned off. If the input voltage rises beyond the under voltage lockout hysteresis, it can return to the original operating situation and does not required to be powered on again. The UVLO threshold is set below the minimum input voltage of 3.8V to avoid any transient VIN drops under the UVLO threshold causing the converter to turn off.

Current Limit Protection

The device has a cycle-by-cycle current limit to protect the internal power MOSFET. If the inductor

current reaches the current limit threshold of 2.2A, the MOSFET will be turned off. It is import to note that this current limit will not protect the output from excessive current if the output is short circuited. If an output short circuit has occurred, excessive current can damage both the inductor and diode.

Output Voltage Protection

Over-Voltage Protection

The device includes an over-voltage protection function. If the one of ISEN pins is shorted to ground or an LED is disconnected from the circuit, the voltage on the ISEN pin will fall to zero and the internal power MOSFET will switch with its full duty cycle. This may cause the output voltage to exceed its maximum voltage rating, possibly damaging the device and external components. The internal over-voltage protection circuitry turns off the power MOSFET and shuts down the device as soon as the output voltage exceeds the V_{OVP} threshold. As a result, the output voltage falls to the level of the input supply voltage. The device remains in this shutdown mode until the V_{OVP} is less than its setup threshold.

LED Open Detector Protection

The device includes an LED open protection function. If any one of ISEN pins is disconnected from the LED load, the device will stop driving the ISEN pin, automatically ignoring the open pin. The LED current of the other ISEN pins will not be influenced by any open ISEN pin. When the open ISEN pins are re-connected to the LED load, there will be no current. These ISEN pins will remain disabled until the power is recycled.

LED Short Detector Protection

The device includes an LED short circuit protection function. If more than 2~3 LEDs are short circuited on any ISEN pin or the voltage level of the ISEN pin is greater than 5.6V, the device will turn off that ISEN pin and automatically ignore the shorted pin. The LED current of other ISEN pins will not be influenced by any shorted ISEN pins. If even only one ISEN pin remains operational due to shorts on other pins, it will still maintain normal operation. The shorted ISEN pins remain disabled until the power is recycled.

Over-Temperature protection – OTP

An internal thermal shutdown function is included to prevent device damage due to excessive heat and power dissipation. Typically, the thermal shutdown threshold of is 140°C. When the thermal shutdown function is activated, the device stops switching until the temperature falls to below 90°C typically. When this occurs the device resumes switching once again.

Soft Start Function

Converter operation starts immediately after power on. In order to avoid the possibility of large in-rush currents to the load during this power on period, a soft-start function is implemented to prevent this problem from occurring.

Application Information**Inductor Selection**

The inductor choice affects steady state operation as well as transient behavior and loop stability. There are three important electrical parameters which need to be considered when choosing an inductor:

- The inductor value
- DCR – copper wire resistance
- The saturation current

Inductor choice is especially important as it is required to ensure the inductor does not saturate under its peak current conditions. The general rule is to keep the inductor current peak-to-peak ripple at approximately 30% of the nominal output current. As a typical example, when using the HT7943 boost converter, operating in both discontinuous and continuous conduction modes, the typical application circuit value of the inductor, L1, would be around 10 μ H.

Input/Output Capacitor**Output Capacitor**

The output capacitor determines the steady state output voltage ripple. In the compensation parameters, the output capacitor is one of the parameters, and if the capacitance is too big or too small, it can cause system instability. Its value must be based on the application circuit recommended output capacitor value. A low ESR ceramic capacitor is required to keep noise to a minimum. A 4.7 μ F ceramic capacitor is suitable for typical applications.

Input Capacitor

An input capacitor is required to supply the ripple current to the inductor and is also used to limit the input noise, allowing the device to obtain a stable DC power supply. As the input capacitance is not a compensation parameter there are no stability problems, however a capacitor must always be connected along with an input power supply. For typical applications, a 4.7 μ F ceramic capacitor is sufficient. This capacitor must be connected very close to the VIN pin and inductor, with short traces for good noise performance.

Schottky Diode

It is recommended to use a Schottky diode with a low forward voltage to minimise power dissipation and therefore maximise the converter efficiency. The average and peak current ratings must be greater than the maximum output current and peak inductor current. There are three important electrical parameters to consider when choosing the diode:

- The diode maximum reverse voltage value must be greater than the maximum output voltage.
- Short recovery time and low forward voltage – use a Schottky diode type.
- Diode current rating should be greater than the maximum load current.

Compensation Components

The COMP pin is the output of the error amplifier and must be properly connected to an external RC network to ensure regulator loop stability. Recommended values are: $R_{Comp}=24k\Omega$ and $C_{Comp}=1.5nF$

Oscillator Frequency Setup

There are two frequency options available. The SWSEL pin default switching frequency is 1MHz when the pin is unconnected and 500kHz when the pin is connected to ground.

LED current Setup

The LED current can be setup using an external resistor connected from the ISENT pin to ground. The following equation shows how the current is calculated:

$$I_{LED}(mA) = \frac{480}{R_{ISET}(k\Omega)}$$

This shows how the Led reference current can be setup at ISEN1-6 and represents the sensed LED current for each string. The LED current regulation between the strings has good accuracy at $\pm 1.5\%$.

Dimming Control

The device includes an external PWM signal dimming control. PWM dimming control is achieved by applying an external PWM signal with a frequency of 100Hz to 20kHz. The high level of this signal must be greater than 2.0V and the low level must be less than 0.8V. A 0% duty cycle corresponds to zero LED current while a 100% duty cycle corresponds to full LED current.

Layout Considerations

Circuit board layout is a very important consideration for switching regulators if they are to function properly. Poor circuit layout may result in related noise problems. In order to minimise EMI and switching noise, the guidelines should be noted:

- All tracks should be as wide as possible.
- The input and output capacitors, C_{IN} and C_{OUT} , should be placed close to the VIN, VOUT and GND pins.
- The Schottky diode, D1, and inductor, L1, must be placed close to the SW pin.
- A full ground plane is always helpful for better EMI performance.
- A recommended PCB layout with component locations is enclosed.

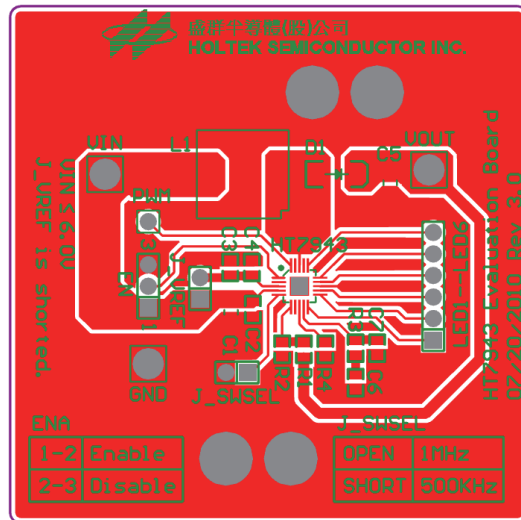

Top Layer

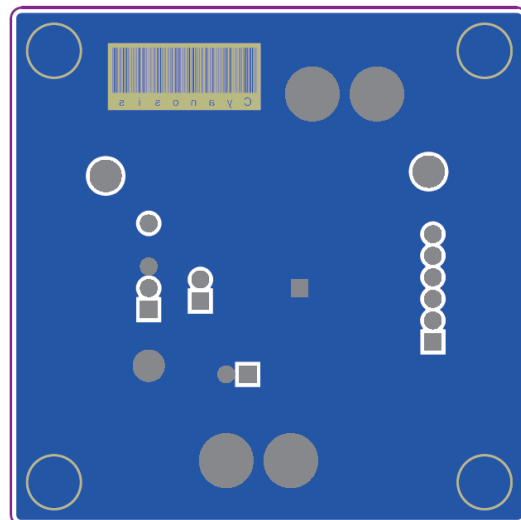

Bottom Layer

Typical Performance Characteristics

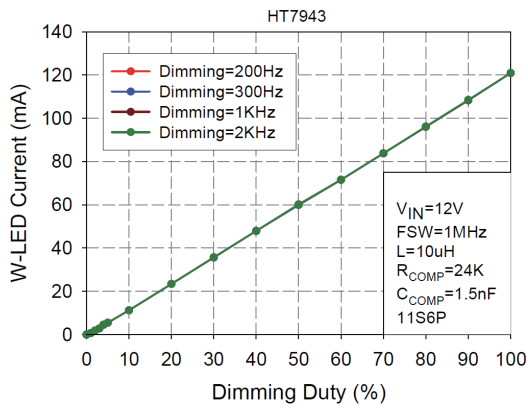

W-LED Current vs PWM Duty

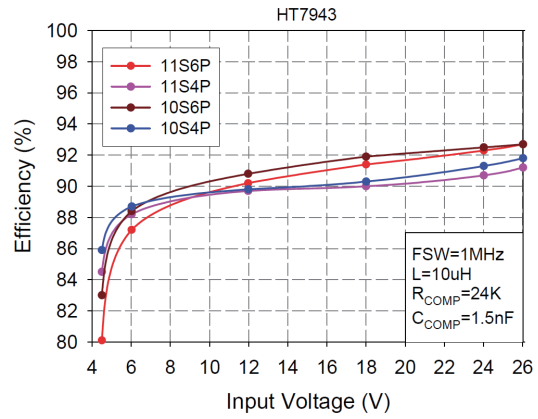

Efficiency vs Input Voltage

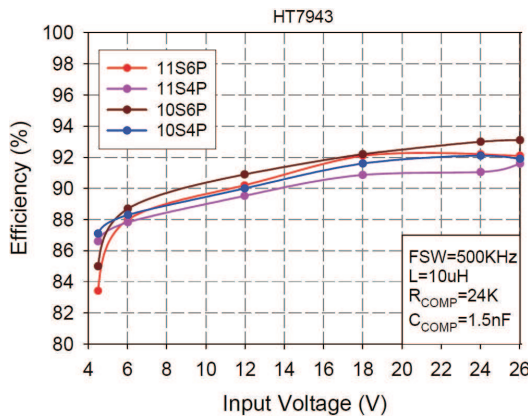

Efficiency vs Input Voltage

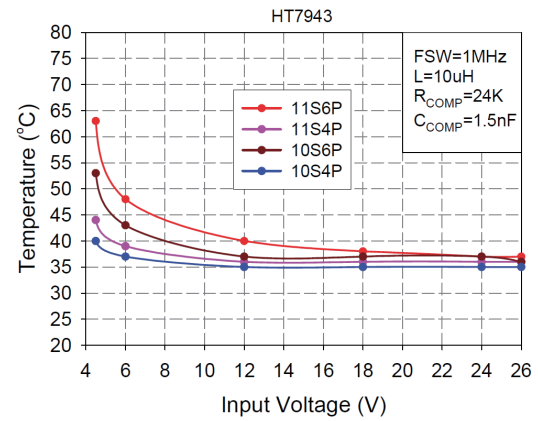

Temperature vs Input Voltage



Basic Waveform
(CH1= $V_{OUT(AC)}$, CH2= I_L , CH3=Switching Pin)

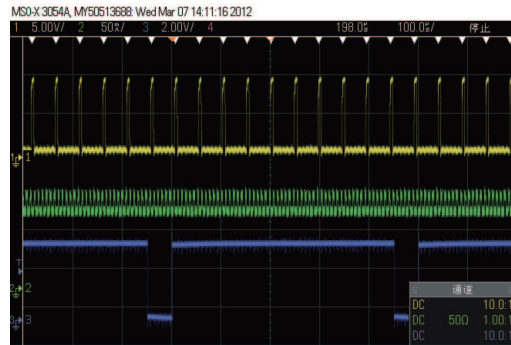

(CH1=one of LED channel Feedback Voltage,
CH2=LED Current, CH3=Dimming signal)
Dimming=2kHz 90%

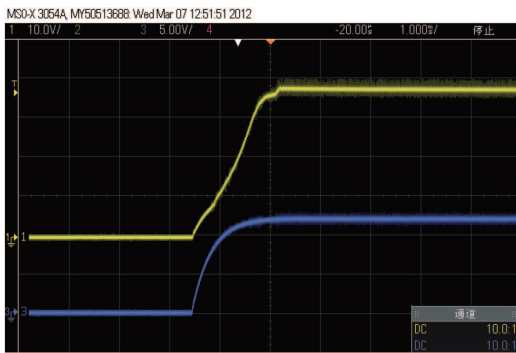

Start up Waveform
(CH1= V_{OUT} , CH2= V_{IN})

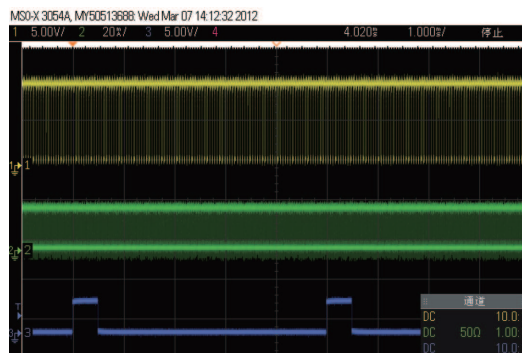

Dimming Waveform
(CH1=one of LED channel Feedback Voltage,
CH2=LED Current, CH3=Dimming signal)
Dimming=200Hz 10%

Package Information

Note that the package information provided here is for consultation purposes only. As this information may be updated at regular intervals users are reminded to consult the Holtek website (<http://www.holtek.com.tw/english/literature/package.pdf>) for the latest version of the package information.

SAW Type 20-pin (4mm×4mm) QFN Outline Dimensions

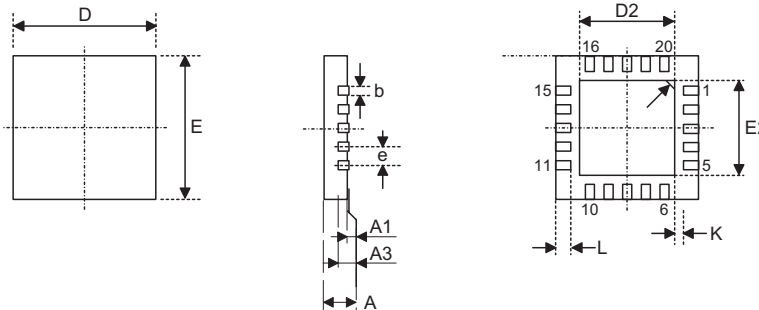

GTK

Symbol	Dimensions in inch		
	Min.	Nom.	Max.
A	0.031	—	0.035
A1	0.000	0.001	0.002
A3	—	0.008	—
b	0.007	0.010	0.012
D	—	0.157	—
E	—	0.157	—
e	—	0.020	—
D2	0.075	—	0.081
E2	0.075	—	0.081
L	0.012	0.016	0.020
K	0.008	—	—

Symbol	Dimensions in mm		
	Min.	Nom.	Max.
A	0.80	—	0.90
A1	0.00	0.02	0.05
A3	—	0.203	—
b	0.18	0.25	0.30
D	—	4.00	—
E	—	4.00	—
e	—	0.50	—
D2	1.90	2.00	2.05
E2	1.90	2.00	2.05
L	0.30	0.40	0.50
K	0.20	—	—

Holtek Semiconductor Inc. (Headquarters)

No.3, Creation Rd. II, Science Park, Hsinchu, Taiwan
Tel: 886-3-563-1999
Fax: 886-3-563-1189
<http://www.holtek.com.tw>

Holtek Semiconductor Inc. (Taipei Sales Office)

4F-2, No. 3-2, YuanQu St., Nankang Software Park, Taipei 115, Taiwan
Tel: 886-2-2655-7070
Fax: 886-2-2655-7373
Fax: 886-2-2655-7383 (International sales hotline)

Holtek Semiconductor (China) Inc. (Dongguan Sales Office)

Building No.10, Xinzhu Court, (No.1 Headquarters), 4 Cuizhu Road, Songshan Lake, Dongguan, China 523808
Tel: 86-769-2626-1300
Fax: 86-769-2626-1311, 86-769-2626-1322

Holtek Semiconductor (USA), Inc. (North America Sales Office)

46729 Fremont Blvd., Fremont, CA 94538, USA
Tel: 1-510-252-9880
Fax: 1-510-252-9885
<http://www.holtek.com>

Copyright© 2012 by HOLTEK SEMICONDUCTOR INC.

The information appearing in this Data Sheet is believed to be accurate at the time of publication. However, Holtek assumes no responsibility arising from the use of the specifications described. The applications mentioned herein are used solely for the purpose of illustration and Holtek makes no warranty or representation that such applications will be suitable without further modification, nor recommends the use of its products for application that may present a risk to human life due to malfunction or otherwise. Holtek's products are not authorized for use as critical components in life support devices or systems. Holtek reserves the right to alter its products without prior notification. For the most up-to-date information, please visit our web site at <http://www.holtek.com.tw>.