

Feature

- Input voltage range: 2.6V~5.5V
- High efficiency - up to 90%
- Integrated N-ch MOSFET
- Can drive up to 39 WLEDs from a 5V input
- Low standby current: 0.1 μ A (typ.)
- Built-in OVP, OCP, OTP, UVLO protection
- EN pin dimming frequency up to 200kHz
- 1.2MHz fixed switching frequency
- SOT23-6 package

Applications

- Display backlighting
 - Automatic
 - DVD player
 - Digital photo frame
 - Handheld computer

General Description

The HT7939A is a high efficiency boost converter for driving multiple White LEDs using current mode operation. The device is designed to drive up to 39 White LEDs from a 5V power supply. The White LED current is setup using an external current setting resistor, which has a low feedback voltage of 0.2V to minimise resistor power losses and thus improving efficiency.

The HT7939A has a dimming frequency of up to 200kHz, which has excellent linear performance over this dimming frequency range. The over voltage function prevents device damage by turning off the converter should the LED load become open circuit. The device also includes over current protection, over temperature protection and under voltage protection preventing damage to the device should the output be overloaded.

Selection Guide

Part No.	Package	Marking
HT7939A	SOT23-6	39A-1 (OVP=17.6V) 39A-2 (OVP=32.0V)

Note: Both lead free and green compound devices are available.

Block Diagram

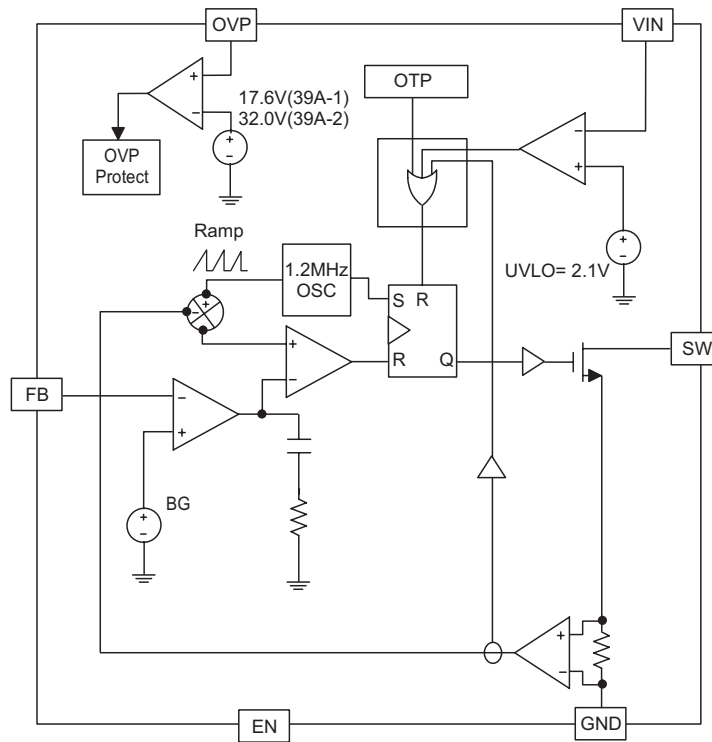

Pin Assignment

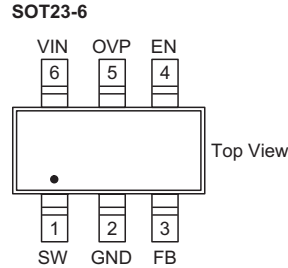

Pin Descriptin

PIN No.	PIN Name	Description
1	SW	Switching pin. Connected to inductor and diode.
2	GND	Ground.
3	FB	Feedback pin. Reference voltage. The HT7939A feedback voltage is 0.2V.
4	EN	Shutdown & Dimming control input. Do not allow this pin to float.
5	OVP	Over voltage protection pin which is connected to the output.
6	VIN	The input supply pin for the IC. Connect VIN to a supply voltage between 2.6V~5.5V.

Absolute Maximum Ratings

Input Voltage, FB Voltage, EN	6.0V	Operating Temperature Range	-40°C to +85°C
SW Voltage	36V	Storage Temperature Range	-55°C to +150°C
OVP Voltage	36V	Maximum Junction Temperature	150°C

Note: These are stress ratings only. Stresses exceeding the range specified under Absolute Maximum Ratings may cause substantial damage to the device. Functional operation of this device at other conditions beyond those listed in the specification is not implied and prolonged exposure to extreme conditions may affect device reliability.

Electrical Characteristics

V_{IN} = 5.0V, T_a = 25°C, unless otherwise specified (note 1)

Symbol	Parameter	Test Conditions	Min.	Typ.	Max.	Unit
Input Supply Voltage and Current						
V_{IN}	Input Voltage	—	2.6	—	5.5	V
UVLO	Under Voltage Lockout	—	1.8	2.1	2.4	V
I_{IN}	Supply Current	Switching	—	1.0	5.0	mA
		VEN= 0	—	0.1	1.0	μA
Error Amplifier						
V_{FB}	Feedback Voltage	—	190	200	210	mV
V	Line Regulation	V_{IN} = 3.0V~4.3V, I_{LED} = 20mA	—	1.0	—	%
Power Switch						
f_{osc}	Switching Frequency	Measured at SW Pin	0.8	1.2	1.6	MHz
DC	Maximum Duty Cycle		85	90	—	%
$R_{DS(ON)}$	SW ON Resistance	—	—	0.5	—	Ω
$I_{SW(OFF)}$	Switch Leakage Current	—	—	0.1	1.0	μA
Enable						
V_{IH}	EN Voltage High	—	2.0	—	—	V
V_{IL}	EN Voltage Low	—	—	—	0.8	V
f_{EN}	Dimming Clock Rate	Duty= 5%~100%	100	—	200	kHz
OVP and OCP						
V_{OVP}	OVP Threshold	No Load, for 39A-1 Marking	15.8	17.6	19.4	V
		No Load, for 39A-2 Marking	28.8	32.0	35.2	V
I_{OCP}	N-channel MOSFET Current limit	—	1000	1200	—	mA
Thermal Shutdown						
t_{SHUT}	Thermal Shutdown Threshold	—	—	150	—	°C
	Thermal Shutdown Hysteresis	—	—	25	—	°C

Note 1. Specifications are production tested at T_a = 25 degree. Specifications over -40°C to 85°C degree operating temperature range are assured by design, characterization.

Functional Description

VIN Under-Voltage Lockout -- UVLO

The HT7939A contains an Input Under Voltage Lockout, UVLO, circuit. The purpose of the UVLO circuit is to ensure that the input voltage is high enough for reliable operation. When the Input Voltage is below the UVLO threshold, the internal power MOSFET will remain switched off. The UVLO threshold is set below the minimum input voltage of 2.6V to avoid any transient VIN drops under the UVLO threshold and causing the converter to turn off.

Current Limit Protection

The HT7939A has a cycle-by-cycle current limit to protect the internal power MOSFET. If the inductor current reaches the current limit threshold, the MOSFET will be turned off. It is important to note that this current limit will not protect the output from excessive current during an output short circuit. If an output short circuit occurs, excessive current can damage both the inductor and the diode.

Over-Voltage Protection -- OVP

The HT7939A provides an over-voltage function. If the FB pin is shorted to ground or an LED is disconnected from the circuit, the FB pin voltage will be zero and the internal power MOSFET will switch at its fully duty cycle. This may cause the output voltage to exceed its maximum voltage rating, possibly damaging the device and the external components. Internal over voltage protection circuitry turns off the power MOSFET and shuts down the device as soon as the output voltage exceeds the threshold. As a result, the output voltage falls to the level of the input supply voltage. The device remains in this shutdown mode until it is enabled once again to a reset condition by the EN pin or after the power is restarted.

Over-Temperature protection -- OTP

A thermal shutdown function is implemented to prevent device damage due to excessive heat and power dissipation. Typically the thermal shutdown threshold is 150°C. When the thermal shutdown is triggered the device stops switching until the temperature falls below a typical value of 125°C. After this the device will once again resume switching.

Application Information

Inductor Selection

There are three important electrical parameters that need to be considered when choosing an inductor. These are the inductor value, the DCR (parasitic serial DC resistance) and the saturation current.

The inductor's value determines the input ripple current. Lower inductor values decrease the physical size of the inductor, but increase the input ripple current. However, larger inductor values decrease the input ripple current, but have higher series resistances and lower saturation currents. A good rule to choose a suitable inductor value is to allow the peak-to-peak ripple current to be approximately 30~50% of the maximum input current. Calculate the required inductance value using the following equations:

$$L = \frac{V_{IN} \times (V_{OUT} - V_{IN})}{V_{OUT} \times F_{SW} \times \Delta I_L}$$

$$I_{IN(MAX)} = \frac{V_{OUT} \times I_{OUT(MAX)}}{V_{IN} \times \eta}$$

$$\Delta I_L = (30\% \sim 50\%) \times I_{IN(MAX)}$$

$$I_{L(PEAK)} = I_{IN(MAX)} + \frac{1}{2} \Delta I_L$$

In the equations above, $I_{OUT(MAX)}$ is the maximum load current, ΔI_L is the peak-to-peak inductor ripple current, η is the converter efficiency, F_{SW} is the switching frequency and $I_{L(PEAK)}$ is the peak inductor current. To prevent inductor core saturation, ensure that the inductor-saturation current is rated higher than the peak inductor current. A 10 μ H inductor value is recommended for most HT7939A applications.

Input and Output Capacitor Selection

The output capacitor determines the steady state output voltage ripple. The voltage ripple is related to the capacitor's capacitance and its ESR which is the Equivalent Series Resistance. Ceramic capacitors with low ESR values will result in the lowest ripple voltage values and are the recommended type. Due to their low ESR values, the capacitance value can be calculated using the following equation:

$$C_{out} = \frac{(V_o - V_{IN}) \times I_{OUT}}{V_{OUT} \times F_{SW} \times V_{ripple}}$$

In the equation above, V_{ripple} = peak to peak output ripple, F_{SW} is the switching frequency.

The output capacitor is recommended to be in a range of 1 μ F to 10 μ F. The input capacitor is required to be in a range of 2.2 μ F to 10.0 μ F. The output capacitor affects the loop stability of the boost regulator. If the output capacitor is lower than this range, the boost regulator could potentially become unstable.

Schottky Diode Selection

The output rectifier diode supplies current to the inductor when the internal MOSFET is off. The average and peak current ratings of the diode must be greater than the maximum output current and peak inductor current. The reverse breakdown voltage must be greater than the maximum output voltage. It is recommended to use a schottky diode with a low forward voltage to minimise power dissipation and therefore to maximise the efficiency of the converter. A 1N5819 diode type is recommended for HT7939A applications.

LED Current Selection

The LED current is controlled by the current sense feedback resistor R_{fb} . The current sense feedback reference is 200mV. In order to ensure accurate LED currents, precision resistors with a 1% tolerance are the preferred types. The LED current can be calculated using the following formula:

$$I_{LED} = \frac{V_{FB}}{R_{fb}} = \frac{200mV}{R_{fb}}$$

Where I_{LED} is the output LED current, V_{FB} =feedback voltage, R_{fb} =current sense resistor.

Digital and Analog Dimming Control

The Digital dimming method uses a PWM signal applied to the EN pin and the EN Pin dimming frequency up to 200kHz. This is shown in fig.19. The average LED current increases proportionally with the PWM signal duty cycle. A 0% duty cycle corresponds to zero LED current. A 100% duty cycle corresponds to a full LED current.

There are two methods to control the LED brightness for analog dimming. The first method uses a DC voltage to control the feedback voltage. If the DC voltage range is from 0V to 3.3V, the selection of resistors provided in fig.20 controls the LED current from 20mA to 0mA. Other applications a filtered PWM signal, which is shown in fig.21. The filtered PWM signal application acts the same way as the DC voltage dimming control.

Typical Performance Characteristics

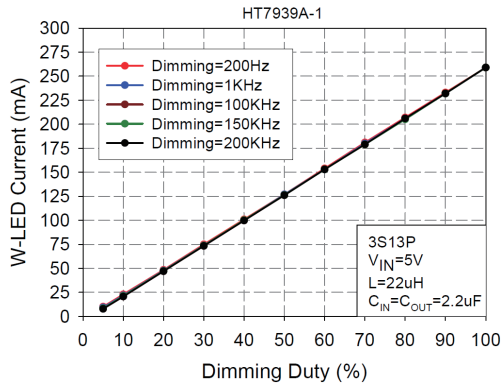

Fig.1 HT7939A-1 W-LED Current V.S. Dimming (3S13P)

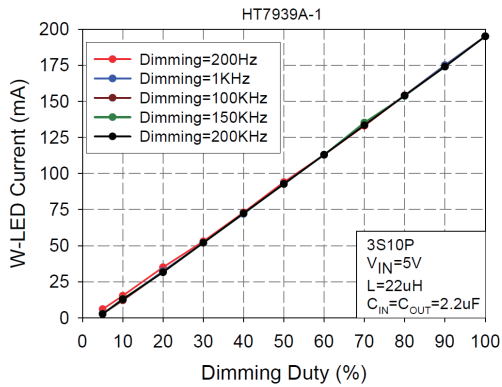

Fig.2 HT7939A-1 W-LED Current V.S. Dimming (3S10P)

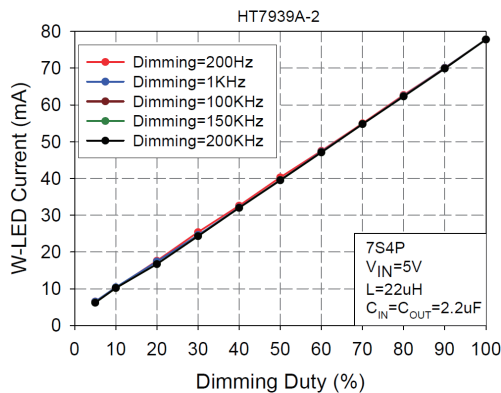

Fig.3 HT7939A-2 W-LED Current V.S. Dimming (7S4P)

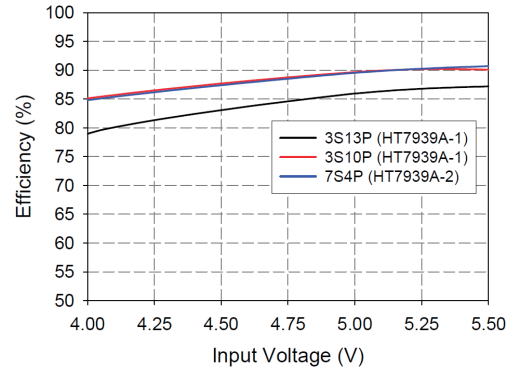

Fig.4 Efficiency V.S. Input Voltage

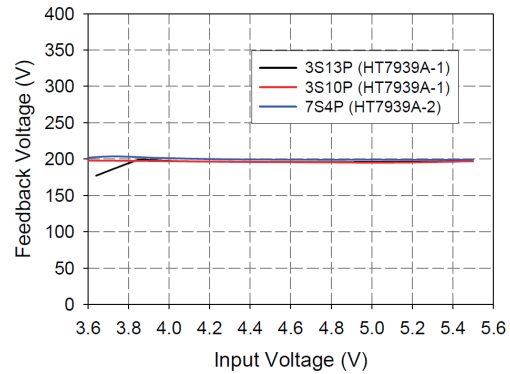

Fig.5 Feedback Voltage V.S. Input Voltage

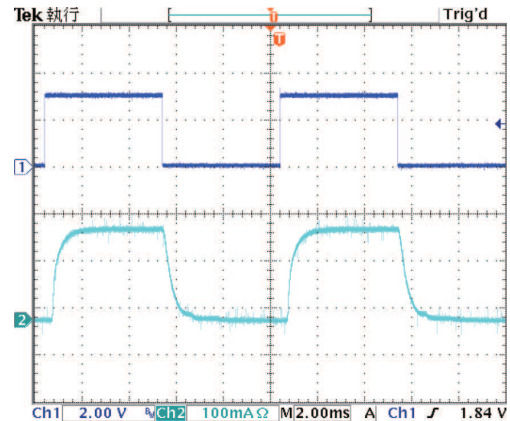

Fig.6 HT7939A-1 3S10P Dimming=100Hz, D=50%,
VIN=5.0V, L=22μH, CIN=COUT=2.2μF
(CH1=VEN Signal, CH2=ILED Current)

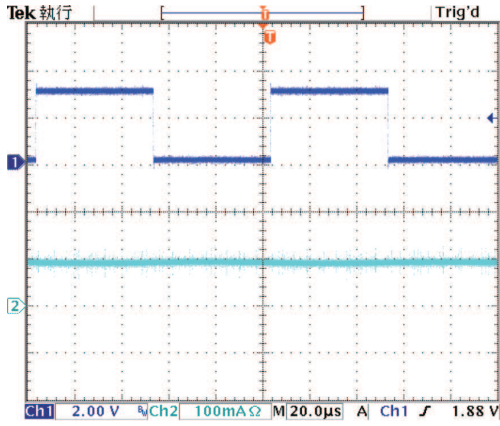

Fig.7 HT7939A-1 3S10P Dimming=10kHz, D=50%,
 $V_{IN} = 5.0V$, $L=22\mu H$, $C_{IN}=C_{OUT}=2.2\mu F$
 (CH1= V_{EN} Signal, CH2= I_{LED} Current)

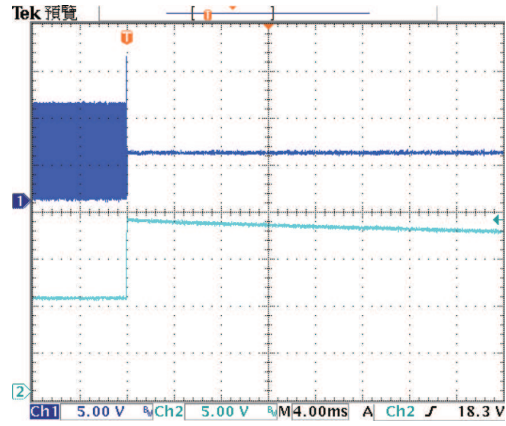

Fig.10 HT7939A-1 3S10P OVP Waveform $V_{IN}=5.0V$
 $L=22\mu H$, $C_{IN}=C_{OUT}=2.2\mu F$
 (CH1=Switching Signal, CH2= V_{OUT})

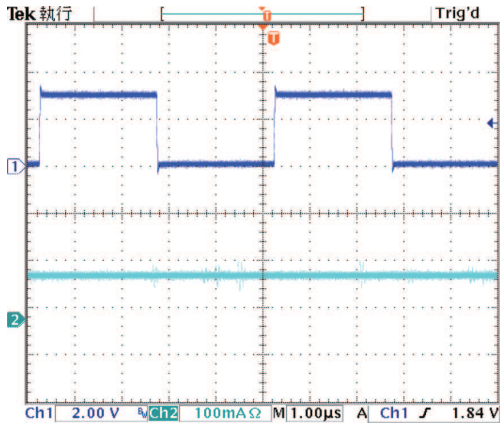

Fig.8 HT7939A-1 3S10P Dimming=200kHz, D=50%,
 $V_{IN}=5.0V$, $L=22\mu H$, $C_{IN}=C_{OUT}=2.2\mu F$
 (CH1= V_{EN} Signal CH2= I_{LED} Current)

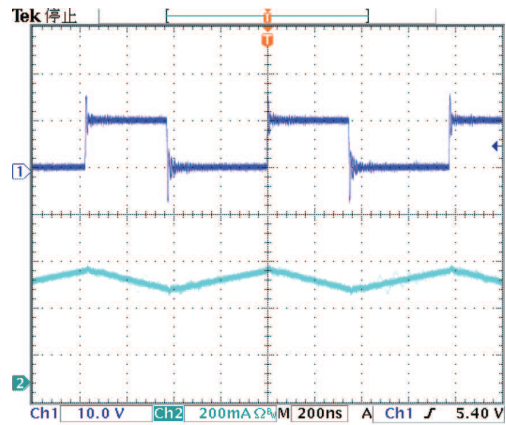

Fig.11 HT7939A-1 3S10P Basic Waveform,
 $V_{IN}=5.0V$, $L=22\mu H$, $C_{IN}=C_{OUT}=2.2\mu F$
 (CH1=Switching Signal, CH2=Inductor Current)

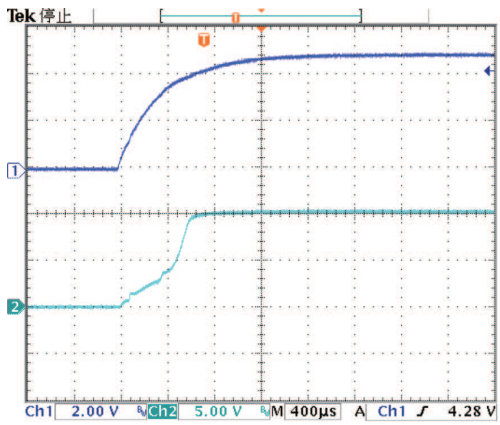

Fig.9 HT7939A-1 3S10P Start Up Waveform
 $V_{IN}=5.0V$, $L=22\mu H$, $C_{IN}=C_{OUT}=2.2\mu F$
 (CH1= C_{IN} , CH2= V_{OUT})

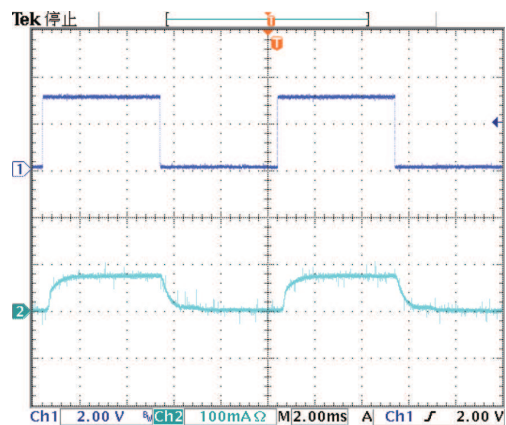

Fig.12 HT7939A-2 7S4P Dimming=100Hz, D=50%
 $V_{IN}=5.0V$, $L=22\mu H$, $C_{IN}=C_{OUT}=2.2\mu F$
 (CH1= V_{EN} Signal, CH2= I_{LED} Current)

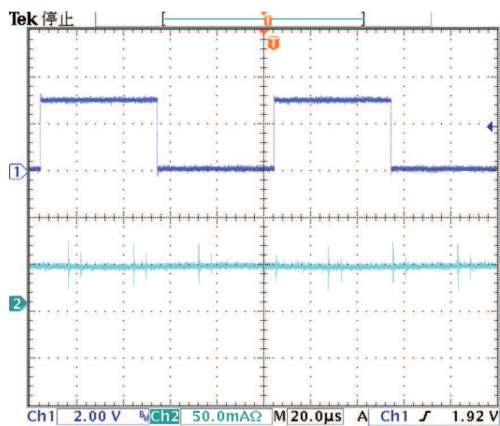

Fig.13 HT7939A-2 7S4P Dimming=10kHz, D=50%
 $V_{IN}=5.0V$, $L=22\mu H$, $C_{IN}=C_{OUT}=2.2\mu F$
 (CH1= V_{EN} Signal, CH2= I_{LED} Current)

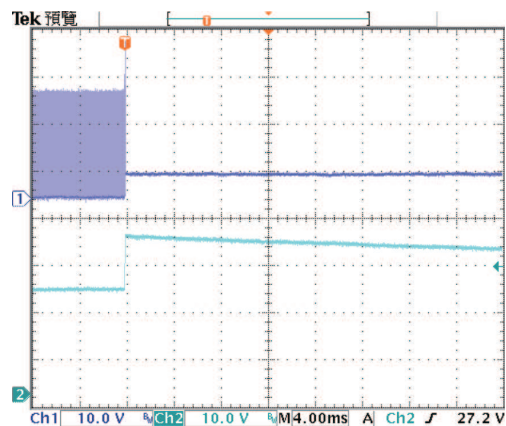

Fig.16 HT7939A-2 7S4P OVP Waveform,
 $V_{IN}=5.0V$, $L=22\mu H$, $C_{IN}=C_{OUT}=2.2\mu F$
 (CH1= Switching Signal, CH2= V_{OUT})

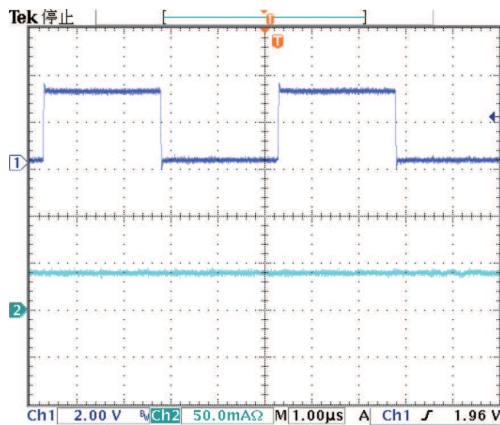

Fig.14 HT7939A-2 7S4P Dimming=200kHz, D=50%,
 $V_{IN}=5.0V$, $L=22\mu H$, $C_{IN}=C_{OUT}=2.2\mu F$
 (CH1= V_{EN} Signal, CH2= I_{LED} Current)

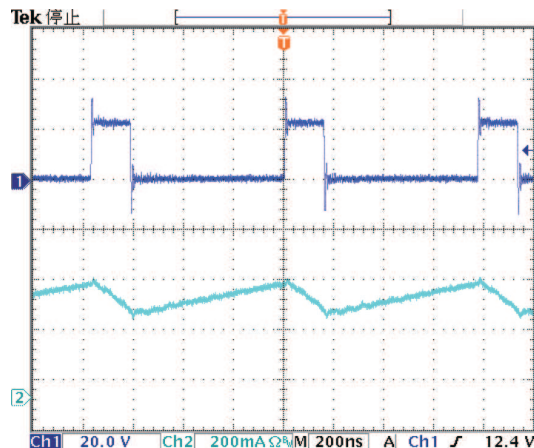

Fig.17 HT7939A-2 7S4P basic waveform,
 $V_{IN}=5.0V$, $L=22\mu H$, $C_{IN}=C_{OUT}=2.2\mu F$

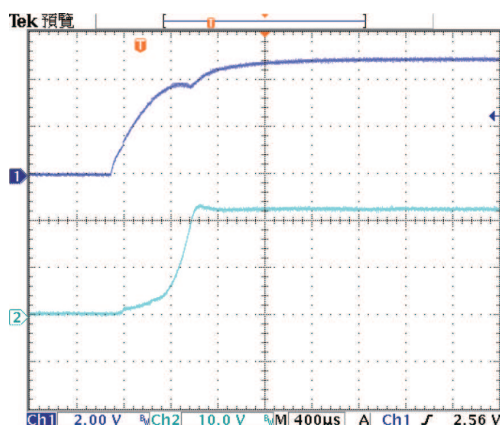
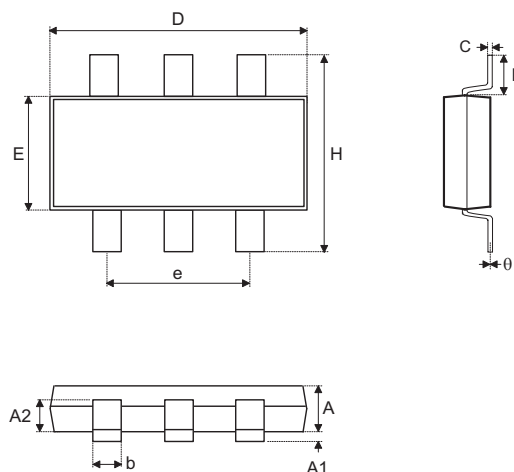

Fig.15 HT7939A-2 7S4P Start Up Waveform,
 $V_{IN}=5.0V$, $L=22\mu H$, $C_{IN}=C_{OUT}=2.2\mu F$
 (CH1= C_{IN} , CH2= V_{OUT})

Package Information

Note that the package information provided here is for consultation purposes only. As this information may be updated at regular intervals users are reminded to consult the Holtek website (<http://www.holtek.com.tw/english/literature/package.pdf>) for the latest version of the package information.

6-pin SOT23-6 Outline Dimensions



Symbol	Dimensions in inch		
	Min.	Nom.	Max.
A	0.039	—	0.051
A1	—	—	0.004
A2	0.028	—	0.035
b	0.014	—	0.020
C	0.004	—	0.010
D	0.106	—	0.122
E	0.055	—	0.071
e	—	0.075	—
H	0.015	—	0.118
L	0.015	—	—
θ	0°	—	9°

Symbol	Dimensions in mm		
	Min.	Nom.	Max.
A	1.00	—	1.30
A1	—	—	0.10
A2	0.70	—	0.90
b	0.35	—	0.50
C	0.10	—	0.25
D	2.70	—	3.10
E	1.40	—	1.80
e	—	1.90	—
H	2.60	—	3.00
L	0.37	—	—
θ	0°	—	9°

Reel Dimensions

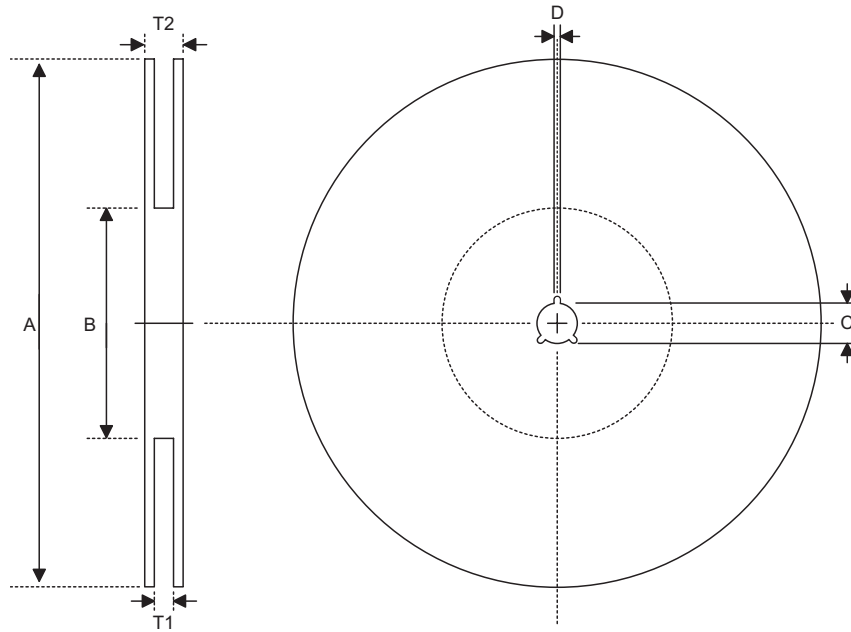

SOT23-6

Symbol	Description	Dimensions in mm
A	Reel Outer Diameter	178.0±1.0
B	Reel Inner Diameter	62.0±1.0
C	Spindle Hole Diamete	13.0±0.2
D	Key Slit Width	2.50±0.25
T1	Space Between Flange	8.4 ^{+1.5/-0.0}
T2	Reel Thickness	11.4 ^{+1.5/-0.0}

Carrier Tape Dimensions

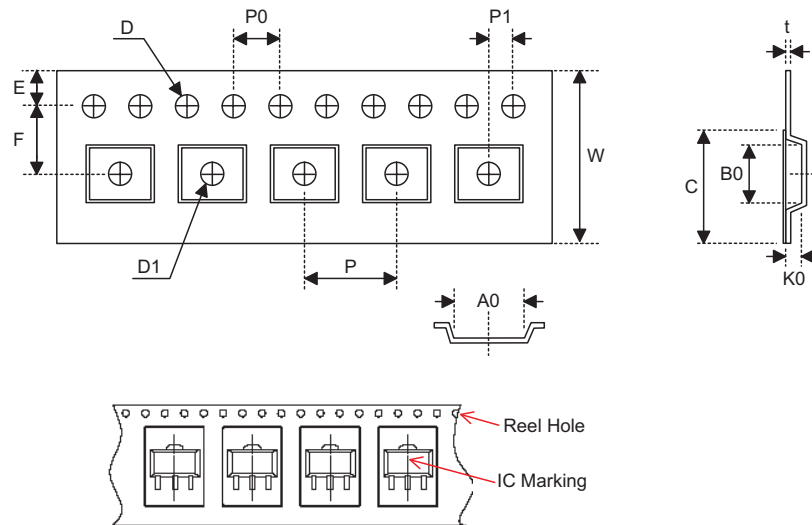

SOT23-6

Symbol	Description	Dimensions in mm
W	Carrier Tape Width	8.0±0.3
P	Cavity Pitch	4.0±0.1
E	Perforation Position	1.75±0.10
F	Cavity to Perforation (Width Direction)	0.50±0.05
D	Perforation Diameter	1.5 ^{+0.1/-0.0}
D1	Cavity Hole Diameter	1.5 ^{+0.1/-0.0}
P0	Perforation Pitch	4.0±0.1
P1	Cavity to Perforation (Length Direction)	2.00±0.05
A0	Cavity Length	3.15±0.10
B0	Cavity Width	3.2±0.1
K0	Cavity Depth	1.4±0.1
t	Carrier Tape Thickness	0.20±0.03
C	Cover Tape Width	5.3±0.1

Holtek Semiconductor Inc. (Headquarters)

No.3, Creation Rd. II, Science Park, Hsinchu, Taiwan
Tel: 886-3-563-1999
Fax: 886-3-563-1189
<http://www.holtek.com.tw>

Holtek Semiconductor Inc. (Taipei Sales Office)

4F-2, No. 3-2, YuanQu St., Nankang Software Park, Taipei 115, Taiwan
Tel: 886-2-2655-7070
Fax: 886-2-2655-7373
Fax: 886-2-2655-7383 (International sales hotline)

Holtek Semiconductor (China) Inc. (Dongguan Sales Office)

Building No.10, Xinzhu Court, (No.1 Headquarters), 4 Cuizhu Road, Songshan Lake, Dongguan, China 523808
Tel: 86-769-2626-1300
Fax: 86-769-2626-1311, 86-769-2626-1322

Holtek Semiconductor (USA), Inc. (North America Sales Office)

46729 Fremont Blvd., Fremont, CA 94538, USA
Tel: 1-510-252-9880
Fax: 1-510-252-9885
<http://www.holtek.com>

Copyright© 2012 by HOLTEK SEMICONDUCTOR INC.

The information appearing in this Data Sheet is believed to be accurate at the time of publication. However, Holtek assumes no responsibility arising from the use of the specifications described. The applications mentioned herein are used solely for the purpose of illustration and Holtek makes no warranty or representation that such applications will be suitable without further modification, nor recommends the use of its products for application that may present a risk to human life due to malfunction or otherwise. Holtek's products are not authorized for use as critical components in life support devices or systems. Holtek reserves the right to alter its products without prior notification. For the most up-to-date information, please visit our web site at <http://www.holtek.com.tw>.